

YTH22V46XLS

Part's Manual

Gasoline containing up to 10% ethanol (E10) is acceptable for use in this machine.
The use of any gasoline exceeding 10% ethanol (E10) will void the product warranty.

TRACTOR -- MODEL NUMBER YTH22V46XLS (96043010301), PRODUCT NO. 960 43 01-03 SCHEMATIC

SCH13

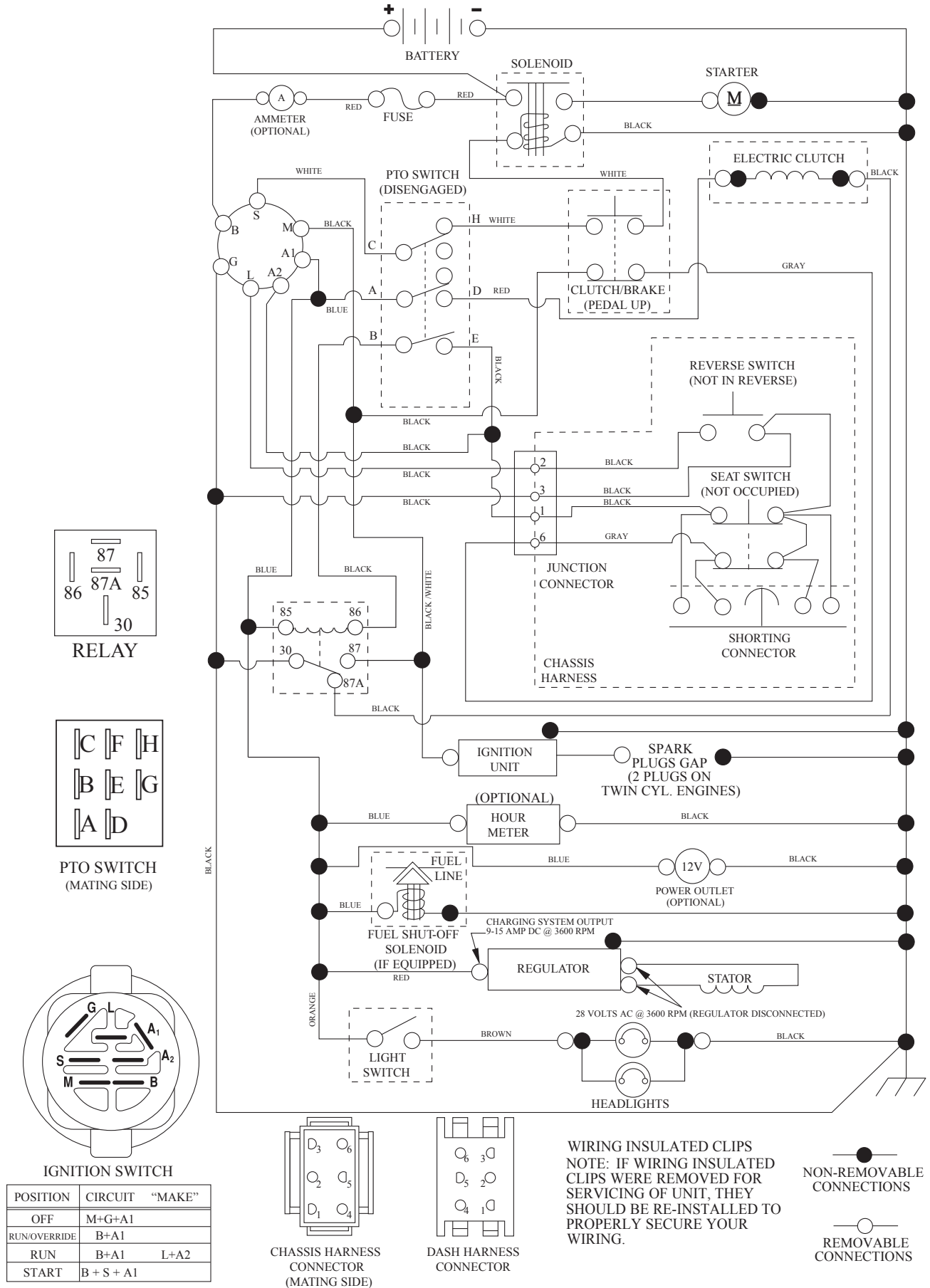

**TRACTOR -- MODEL NUMBER YTH22V46XLS (96043010301), PRODUCT NO. 960 43 01-03
ELECTRICAL**

T27S

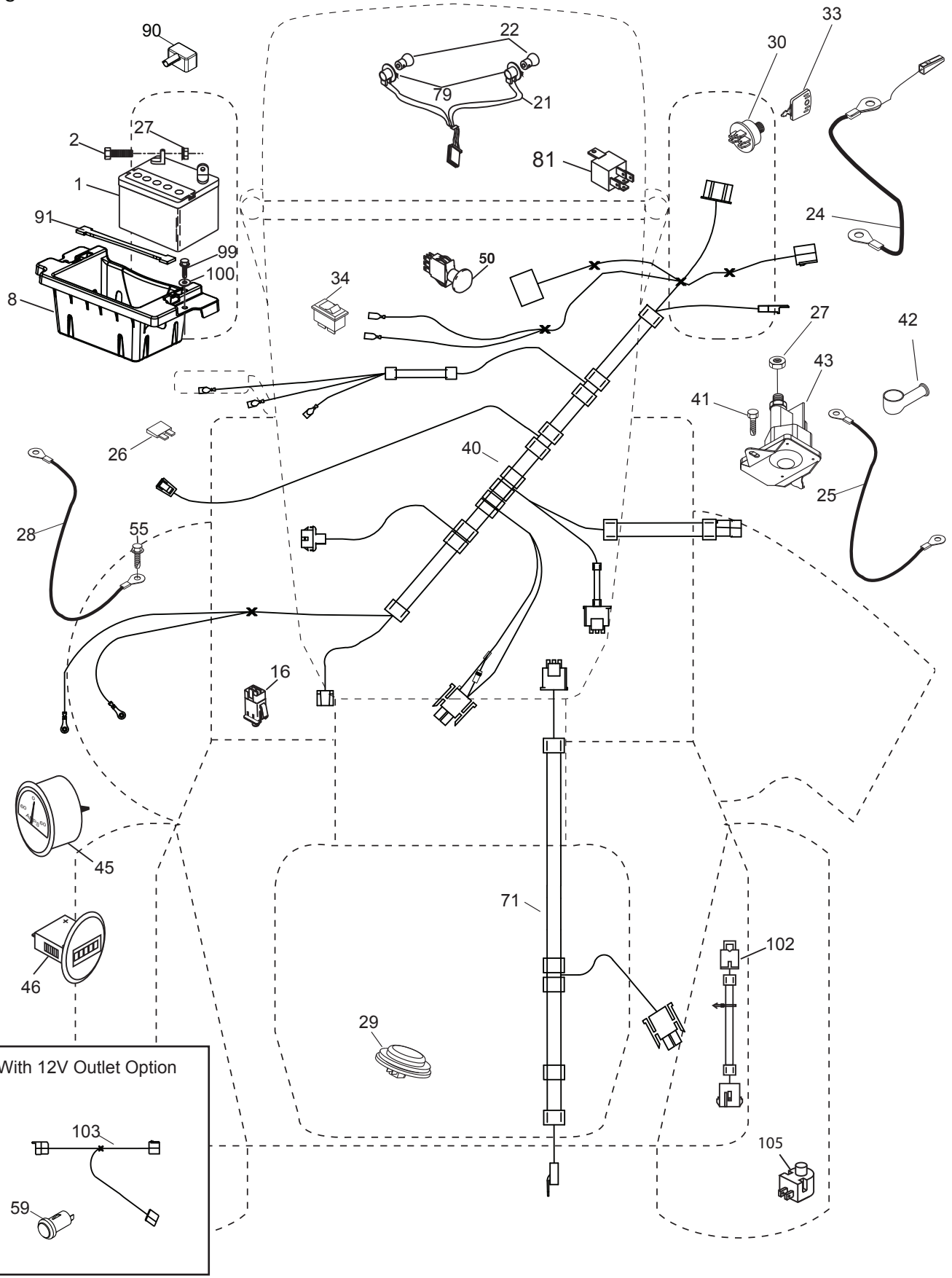

**TRACTOR -- MODEL NUMBER YTH22V46XLS (96043010301), PRODUCT NO. 960 43 01-03
ELECTRICAL**

KEY NO.	PART NO.	DESCRIPTION
1	532 16 34-65	Battery
2	874 76 04-12	Bolt Hex Head 1/4-20 x 3/4
8	532 18 64-91	Box Battery
16	532 17 61-38	Switch Interlock Push-In
21	532 18 37-59	Harness Socket Light w/4152J
22	532 00 41-52	Bulb Light
24	532 40 02-53	Cable Battery
25	532 41 28-95	Cable Starter
26	532 17 51-58	Fuse
27	873 51 04-00	Nut Keps Hex 1/4-20 unc
28	532 14 54-91	Cable, Ground
29	532 40 15-45	Switch, Seat
30	532 19 33-50	Switch, Ign
33	532 41 19-35	Key\Chain
34	532 11 07-12	Switch Light / Reset
40	532 42 56-75	Harness Ign. Dash
41	817 72 04-08	Screw Thd Cut 1/4-20 x 1/2
42	532 13 15-63	Cover, Terminal
43	532 19 25-07	Solenoid
45	532 42 52-70	Ammeter Gauge Round
46	532 42 52-71	Gauge Servicere minder Hrmtr
50	532 17 46-51	Switch PTO
55	817 06 05-12	Screw Thdrol 5/16-18 x 3/4 TYTT
59	532 40 03-03	Outlet 12-Volt
71	532 19 42-76	Harness Ign.
79	532 17 52-42	Socket Asm Bulb Twistlock
81	532 40 96-15	Relay Harness Sealed
90	532 40 07-24	Cover Terminal
91	532 19 02-70	Strap Battery Mount
99	817 67 04-12	Screw Hexwsh Thdrol 1/4-20 x 3/4
100	819 09 14-16	Washer 9/32 x 7/8 x 16 Ga.
102	532 40 44-54	Harness Pigtail
103	532 42 17-47	Harness 12-Volt Pigtail
105	532 40 75-68	Switch Reverse TT Pedal Control

NOTE: All component dimensions given in U.S. inches
1 inch = 25.4 mm

**TRACTOR -- MODEL NUMBER YTH22V46XLS (96043010301), PRODUCT NO. 960 43 01-03
CHASSIS**

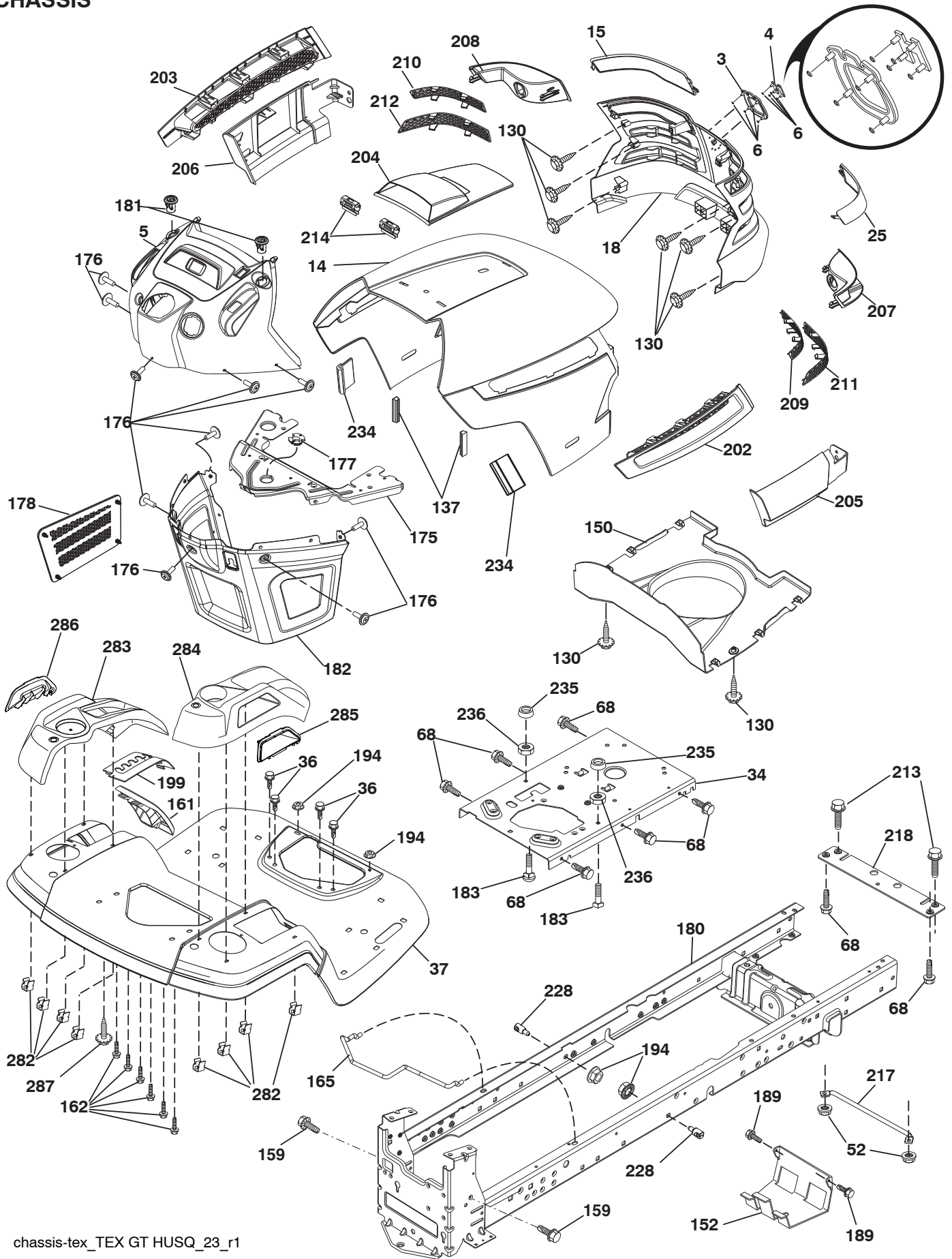

chassis-tex_TEX GT HUSQ_23_r1

**TRACTOR -- MODEL NUMBER YTH22V46XLS (96043010301), PRODUCT NO. 960 43 01-03
CHASSIS**

KEY NO.	PART NO.	DESCRIPTION	KEY NO.	PART NO.	DESCRIPTION
3	532 40 86-06	Trim, Husq.	199	532 41 34-85	Plate Deck Lift
4	532 40 50-12	Logo	202	532 40 30-48	Vent Side Hood RH
5	532 44 84-37	Dash	203	532 40 30-76	Vent Side Hood LH
6	532 11 04-52	Nut, Push	204	532 41 66-13	Vent Top Hood
14	532 41 10-46	Hood	205	532 40 17-09	Skirt Hood Side RH
15	532 19 89-07	Lens LH	206	532 40 17-11	Skirt Hood Side LH
18	532 40 86-07	Grille/Lens Asm.	207	532 19 71-98	Bezel RH
25	532 19 89-06	Lens RH	208	532 19 71-99	Bezel LH
34	532 19 61-25	Plate Engine	209	532 19 91-30	Insert Hex Top RH
36	817 06 05-12	Screw 5/16-18 x 3/4	210	532 19 91-31	Insert Hex Top LH
37	532 44 11-78	Fender	211	532 19 91-32	Insert Hex Bottom RH
52	873 68 05-00	Nut Lock 5/16-18	212	532 19 91-33	Insert Hex Bottom LH
68	817 49 05-08	Screw Thdrol 5/16-18 x 1/2	213	874 76 05-12	Bolt 5/16-18 x 3/4
130	532 41 63-58	Screw 10 x .750 BOS Thread	214	532 19 91-45	Clip Retainer Tinner
137	532 40 75-90	Bumper Dash	217	532 40 91-67	Rod Pivot
150	532 19 85-12	Air Duct	218	532 19 63-95	X-Piece Hood Stop
152	532 19 95-35	Shield Browning	228	532 19 51-61	Stud Fastner
159	817 00 06-12	Screw Hexwsh Thdr 3/8-16 x 3/4	234	532 40 47-42	Bumper Hood
161	532 40 96-27	Window, Fuel	235	532 40 61-29	Spacer Fender
162	532 14 24-32	Screw Hex Wsh 1/4 x 1/2 unc	236	873 93 05-00	Nut Lock 5/16-18 unc
165	532 19 68-26	Support Tank Rear	282	532 41 41-10	Clip Retainer
175	532 19 63-04	Crossmember	283	532 41 87-41	Console Deck Lift
176	532 40 07-76	Screw 10-24 x 5/8	284	532 41 78-87	Console Control
177	532 19 52-27	Bushing Steering	285	532 41 63-15	Console Insert RH
178	532 19 97-82	Cargo Net Asm.	286	532 41 63-17	Console Insert LH
180	532 19 54-57	Chassis	287	817 60 04-06	Screw Hex Washhead 1/4-20 x 3/8
181	532 40 30-25	Bushing Mtg. Fender Crgo	--	532 43 18-82	Kit Guard Brush
182	532 40 68-59	Dash Lower			
183	874 52 05-20	Bolt 5/16-18 x 1-1/4 Full Thd.			
189	817 00 05-12	Screw 5/16-18 x 3/4			
194	873 90 05-00	Nut Lock Hex Flange 5/16-18			

NOTE: All component dimensions given in U.S. inches
1 inch = 25.4 mm

TRACTOR -- MODEL NUMBER YTH22V46XLS (96043010301), PRODUCT NO. 960 43 01-03
DRIVE

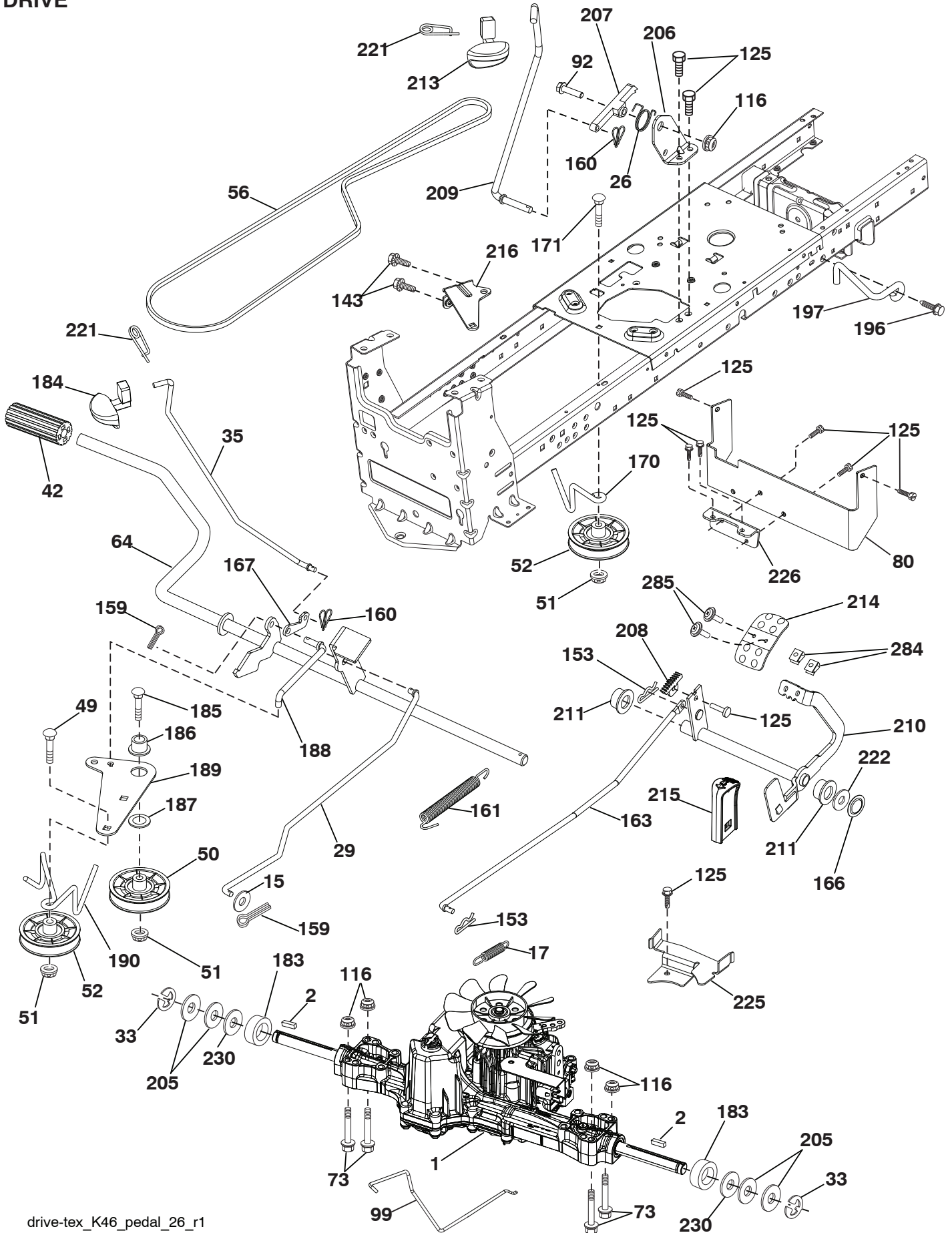

**TRACTOR -- MODEL NUMBER YTH22V46XLS (96043010301), PRODUCT NO. 960 43 01-03
DRIVE**

KEY NO.	PART NO.	DESCRIPTION	KEY NO.	PART NO.	DESCRIPTION
1	-----	Transaxle, TUFFTORQ K46BT	185	872 11 06-22	Bolt Rdhd Sqnk 3/8-16 x 2-3/4 Gr. 5
2	532 12 35-83	Key	186	532 19 43-21	Spacer Retainer
15	819 13 13-16	Washer 13/32 x 13/16 x 16 Ga.	187	819 13 32-10	Washer
17	532 41 36-78	Spring, Brake	188	532 19 43-23	Link Clutch Ground Drive
26	532 19 96-79	Spring Return Cruise	189	532 19 43-17	Bellcrank Ground Drive
29	532 40 38-06	Rod, Brake	190	532 19 43-18	Keeper Bellcrank Ground Drive
33	812 00 00-01	Ring E	196	817 00 06-16	Screw 3/8-16 x 1
35	532 19 95-91	Rod, Brake, Park	197	532 19 58-04	Bracket Clutch Anti-Rotation
42	532 12 48-72	Cover, Foot Pedal	205	532 12 17-48	Washer
49	872 11 06-14	Bolt	206	532 19 78-67	Bracket Mount Latch Cruise
50	532 19 43-27	Pulley Idler Flat	207	532 19 78-68	Latch Control Cruise
51	873 90 06-00	Lock Nut 3/8-16	208	532 19 78-69	Gear Sector Control Cruise
52	532 19 43-26	Idler V-Groove 910" Offset	209	532 19 95-92	Rod Control Cruise
56	532 13 09-69	V-Belt, Drive	210	532 40 09-80	Rocker Asm. Pedal Control
64	532 19 78-65	Shaft Asm. Pedal Brake Control	211	532 12 01-83	Bearing Nylon
73	874 49 05-44	Bolt Hex Flghd 5/16-18 Gr. 5	213	532 40 31-19	Knob Control Cruise
80	532 41 00-24	Bracket Strap Torque	214	532 41 68-63	Pedal Forward
92	874 76 05-20	Bolt Fin Hex 5/16-18 unc x 1.25	215	532 40 17-23	Pedal Reverse
99	532 41 57-42	Rod Spring Bypass	216	532 19 61-31	Bracket Pulley Idler
116	873 90 05-00	Nut Lock Hex Flange 5/16-18	221	532 40 31-87	Retainer Spring Clip Handle
125	817 00 05-12	Screw 5/16-18 x 3/4	222	879 21 20-10	Washer 21/32 x 1-1/4 x 10 Ga.
143	817 49 05-08	Screw 5/16-18 x 1/2	225	532 40 33-19	Keeper Belt Trans.
153	532 12 47-88	Retainer Spring	226	532 40 15-64	Bracket Mount Touque
159	876 02 04-12	Pin Cotter 1/8 x 3/4	230	532 18 89-67	Washer Hardened
160	532 16 94-84	Retainer Clip	284	532 41 76-93	Nut U-CHNL 1/4-20 550DP .350 PNL
161	532 10 57-09	Spring, Return, Clutch	285	532 41 77-65	Screw PHD 1/4-20 Box Drive
163	532 40 10-34	Rod Pedal Control			
166	532 42 91-64	Nut Push			
167	532 40 52-57	Latch Brake Parking			
170	532 19 43-22	Keeper Belt Centerspan			
171	872 11 06-16	Bolt RDHD SQNK 3/8-16 unc x 2			
183	532 13 70-57	Spacer Split			
184	532 40 31-18	Handle Parking Brake			

NOTE: All component dimensions given in U.S. inches
1 inch = 25.4 mm

TRACTOR -- MODEL NUMBER YTH22V46XLS (96043010301), PRODUCT NO. 960 43 01-03
ENGINE

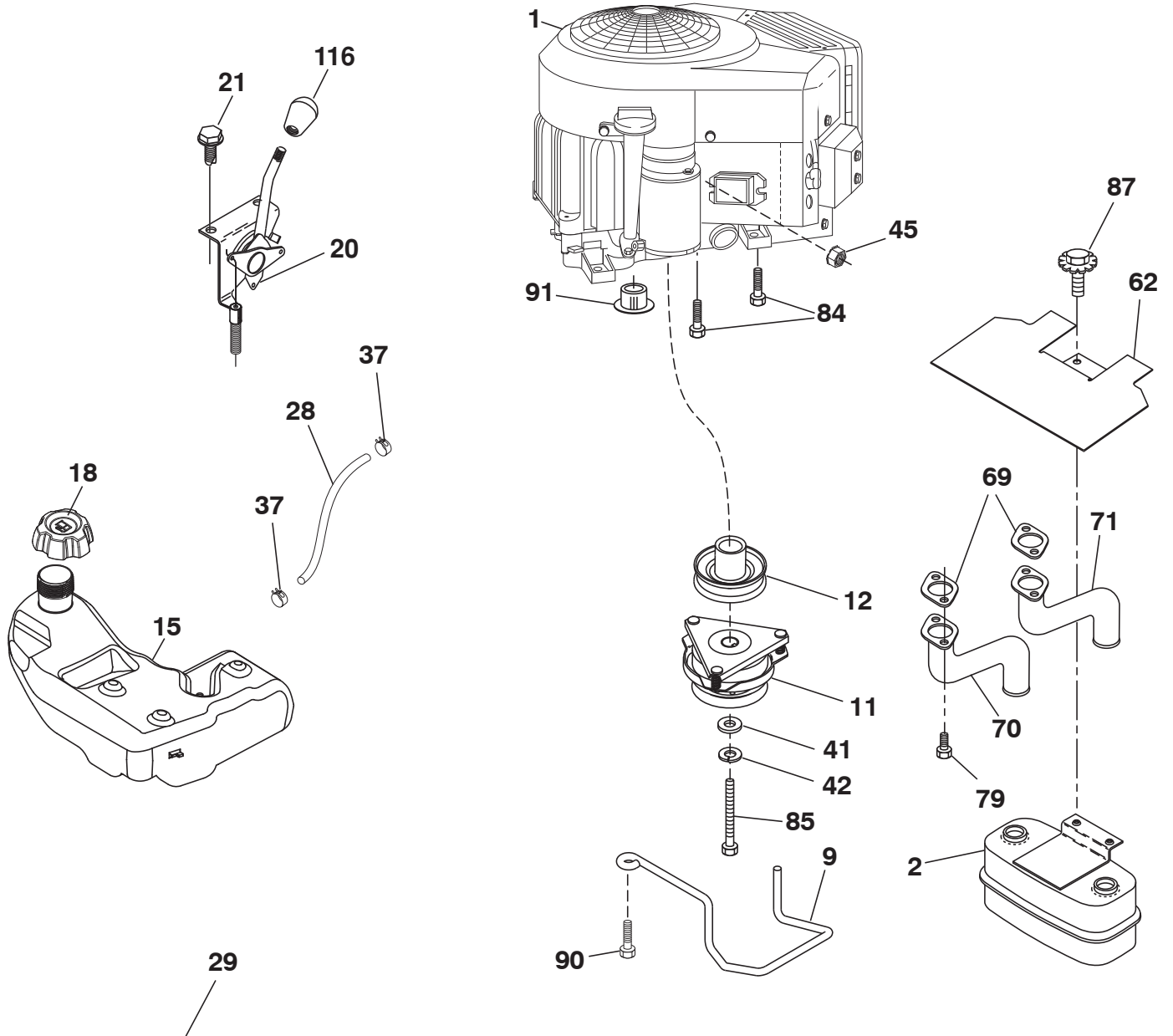

SPARK ARRESTER KIT

engine-tex_bs-2cyl_23

**TRACTOR -- MODEL NUMBER YTH22V46XLS (96043010301), PRODUCT NO. 960 43 01-03
ENGINE**

KEY NO.	PART NO.	DESCRIPTION
1	-----	Engine Briggs & Stratton Model No. 40H777-1421-B1
2	532 14 97-23	Muffler
9	532 19 43-20	Keeper Belt Engine
11	532 40 00-08	Clutch
12	532 40 50-97	Pulley Engine
15	532 43 80-80	Tank Fuel
18	532 43 92-08	Cap Asm Fuel
20	532 42 43-40	Control Throttle/Choke
21	532 41 63-58	Screw #10 x .750 BOS Thread
28	532 40 11-35	Fuel Line
29	532 13 71-80	Spark Arrester Kit
37	532 12 34-87	Clamp Hose
41	532 12 61-97	Washer 1-1/2 OD x 15/32 ID x .250
42	810 04 07-00	Washer Lock 7/16
45	873 51 04-00	Nut Keps Hex 1/4-20 unc
62	532 43 40-17	Heat Shield
69	532 16 53-91	Gasket
70	532 15 99-55	Exhaust Tube LH
71	532 16 05-89	Exhaust Tube RH
79	532 18 39-06	Screw Socket Head 5/16-18 x1
84	817 06 06-20	Screw 3/8-16 x 1-1/4
85	532 17 39-37	Bolt Hex 7/16-20 x 4 x Gr. 5-1.5 Thr
87	537 17 18-77	Bolt 5/16-18 unc x 3/4 w/Sems
90	817 00 06-16	Screw 3/8-16 x 1
91	532 18 74-95	Bushing
116	539 13 26-24	Knob Soft Touch

NOTE: All component dimensions given in U.S. inches
1 inch = 25.4 mm

For engine service and replacement parts, call the toll free number for your engine manufacturer listed below:

Briggs & Stratton 1-800-233-3723

Engine Power Rating Information

The gross power rating for individual gas engine models is labeled in accordance with SAE (Society of Automotive Engineers) code J1940 (Small Engine Power & Torque Rating Procedure), and rating performance has been obtained and corrected in accordance with SAE J1995 (Revision 2002-05). Torque values are derived at 3060 RPM; horsepower values are derived at 3600 RPM. Actual gross engine power will be lower and is affected by, among other things, ambient operating conditions and engine-to-engine variability. Given both the wide array of products on which engines are placed and the variety of environmental issues applicable to operating the equipment, the gas engine will not develop the rated gross power when used in a given piece of power equipment (actual "on-site" or net power). This difference is due to a variety of factors including, but not limited to, accessories (air cleaner, exhaust, charging, cooling, carburetor, fuel pump, etc.), application limitations, ambient operating conditions (temperature, humidity, altitude), and engine-to-engine variability. Due to manufacturing and capacity limitations, Briggs & Stratton may substitute an engine of higher rated power for this Series engine.

TRACTOR -- MODEL NUMBER YTH22V46XLS (96043010301), PRODUCT NO. 960 43 01-03
STEERING ASSEMBLY

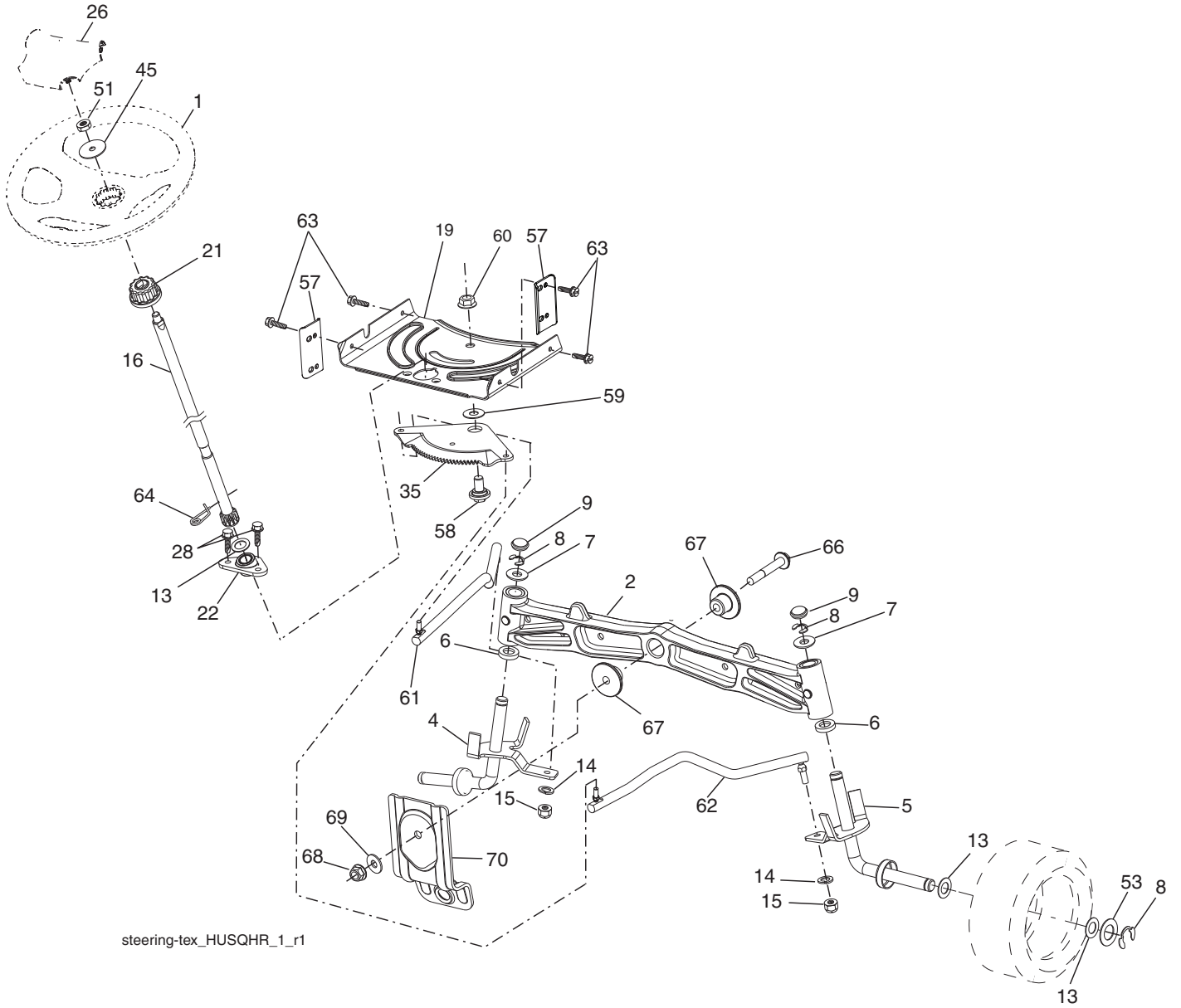

**TRACTOR -- MODEL NUMBER YTH22V46XLS (96043010301), PRODUCT NO. 960 43 01-03
STEERING ASSEMBLY**

KEY NO.	PART NO.	DESCRIPTION
1	532 41 64-80	Wheel, Steering
2	532 19 59-68	Axle Asm., Front
4	532 40 30-87	Spindle Asm., LH
5	532 40 30-88	Spindle Asm., RH
6	532 12 49-31	Bearing, Race Thrust Harden
7	532 12 17-48	Washer 25/32 x 1-5/8 x 16 Ga.
8	812 00 00-29	Ring, Klip #T5304-75
9	532 12 12-32	Cap, Spindle
13	532 12 17-49	Washer 25/32 x 1-1/4 x 16 Ga.
14	810 04 06-00	Washer, Lock Hvy Hlcl Spr 3/8
15	873 54 06-00	Nut, Crown Lock 3/8-24 unf
16	532 40 82-19	Shaft Steering
19	532 19 47-29	Plate Steering
21	532 18 67-37	Adapter, Wheel Steering
22	532 42 05-37	Strg. Supt. Lower
26	532 41 59-87	Insert, Wheel Steering
28	817 00 06-12	Screw 3/8-16 x 3/4
35	532 19 47-32	Gear, Sector Plate
45	819 18 38-12	Washer 9/16 ID x 2-3/8 OD 12 Ga.
51	873 94 08-00	Nut Hex Jam Toplock 1/2-20 unf
53	532 18 89-67	WasherHardened.793x1.637x.060
57	532 40 74-65	Bracket Upstop
58	532 19 47-47	Bolt Shoulder Sector Pivot CFM
59	532 19 47-48	Washer Thrust Sector Steering
60	873 97 10-00	Nut Flange Lock 5/8-11
61	532 19 47-40	Draglink LH
62	532 19 47-41	Draglink, RH
63	817 00 05-12	Screw 5/16-18 x 3/4
64	532 19 98-49	Retainer Clip Spring Steering
66	871 02 07-48	Bolt Hex Fghd 7/16-14 x 3 Serr
67	532 19 47-37	Bushing PM Front Axle
68	873 90 07-00	Nut Lock Flange 7/16-14 Gr. 5
69	532 19 91-62	Washer 1.5 x .505 x .118
70	532 19 61-97	Bracket Deck Susp. Front

NOTE: All component dimensions given in U.S. inches
1 inch = 25.4 mm

**TRACTOR -- MODEL NUMBER YTH22V46XLS (96043010301), PRODUCT NO. 960 43 01-03
MOWER DECK**

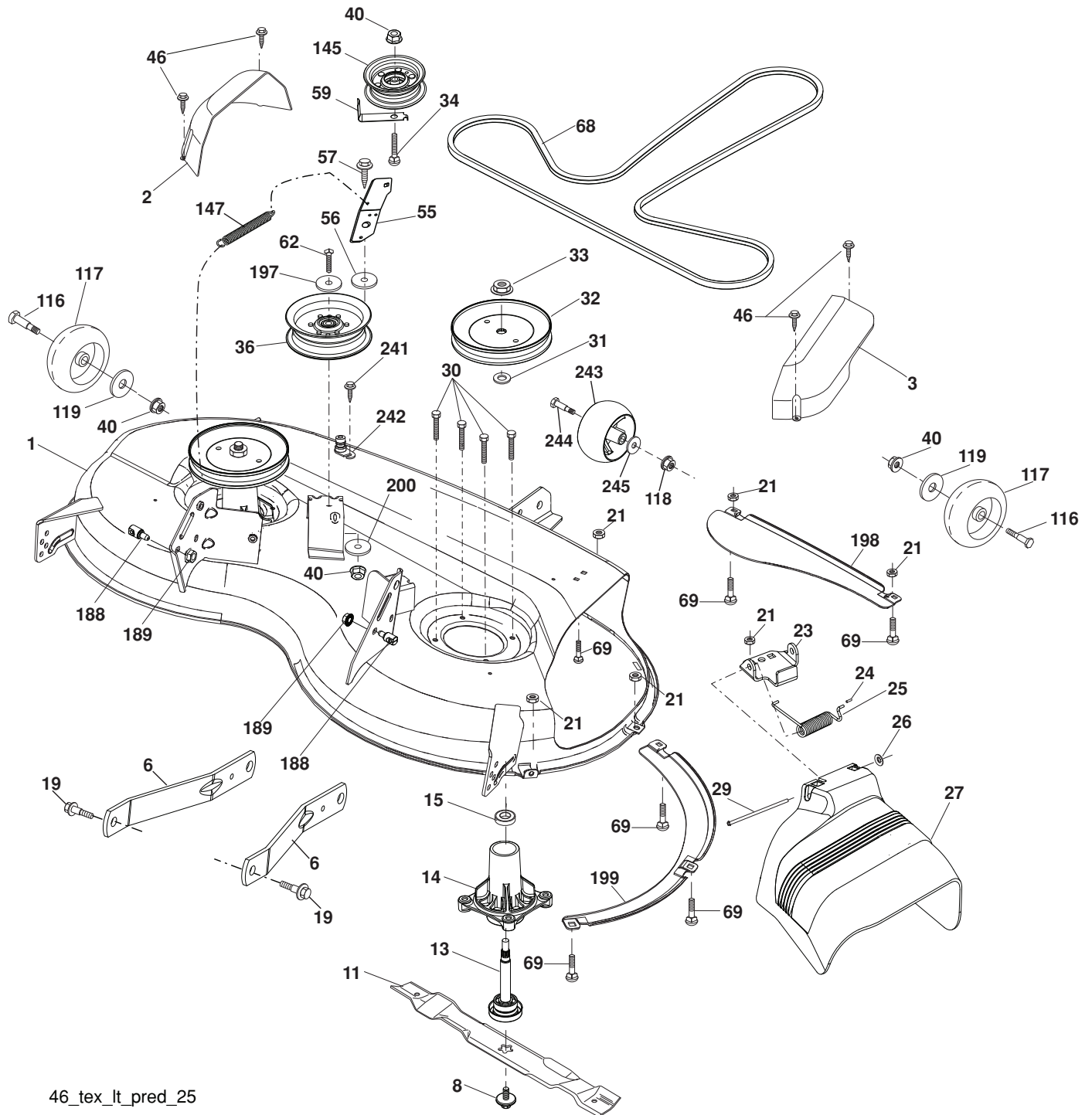

46_tex_lt_pred_25

**TRACTOR -- MODEL NUMBER YTH22V46XLS (96043010301), PRODUCT NO. 960 43 01-03
MOWER DECK**

KEY PART		DESCRIPTION	KEY PART		DESCRIPTION
NO.	NO.		NO.	NO.	
1	532 44 24-05	Mower Housing	68	532 40 51-43	V-Belt
2	532 40 55-07	Cover Mandrel RH	69	872 14 05-05	Bolt
3	532 40 55-06	Cover Mandrel LH	116	532 19 34-06	Bolt, Shoulder
6	532 19 51-86	Arm Suspension	117	532 17 48-73	Wheel, Gauge
8	532 19 30-03	Bolt/Washer asm 7/16-20 unf	118	873 90 06-00	Nut Centerlock 3/8-16 unc
11	532 40 53-80	Blade Mower Hi Lift	119	819 13 20-12	Washer 13/32 x 1-1/2 x 11 Ga.
13	532 19 28-72	Shaft Assembly, Mandrel	145	532 19 31-97	Pulley Idler
14	532 18 72-81	Housing, Mandrel	147	532 19 72-51	Spring Return
15	532 11 04-85	Bearing, Ball, Mandrel	188	532 19 51-61	Stud Fastener
19	532 19 65-39	Bolt, Shoulder	189	873 90 05-00	Nut Lock Hex Flange
21	873 68 05-00	Nut	197	819 13 13-12	Washer 13/32 x 13/16 x 12 Ga.
23	532 19 25-57	Bracket, Deflector	198	532 40 31-49	Baffle Center Front
24	532 10 53-04	Cap, Sleeve	199	532 40 31-50	Baffle Front RH
25	532 19 70-26	Spring, Torsion, Deflector	200	532 41 35-24	Washer 13/32x1x1/2 11 GAHRD
26	532 11 04-52	Nut, Push	241	532 15 29-27	Screw
27	532 40 53-57	Shield, Deflector	242	532 41 55-98	Washout Port
29	532 13 14-91	Rod, Hinge	243	532 18 86-06	Wheel Gauge Half Spoked
30	532 17 39-84	Screw Thdrol Rolling Wsh Hd	244	532 12 48-42	Bolt Shoulder "A" 2.41. "B" 1.66
31	532 18 76-90	Washer, Spacer	245	819 12 14-14	Washer 3/8 x 7/8 x 14 Ga.
32	532 19 74-73	Pulley, Mandrel	--	532 41 64-05	Coupling Quick Connect
33	532 40 02-34	Nut, Toplock, Flanged	--	532 19 28-70	Mandrel Assembly (Includes housing, shaft assembly, and bearing only - pulley/nut/washer and blade bolt/washers not included)
34	872 11 06-12	Bolt Carr Sh. 3/8-16 x 1-1/2 Gr. 5	--	532 41 82-26	Replacement Mower, Complete
36	532 19 73-79	Pulley, Idler, Flat			
40	873 90 06-00	Nut, Lock Flg. 3/8-16 unc			
46	532 13 77-29	Screw			
55	532 19 72-49	Arm, Idler			
56	532 19 90-92	Spacer, Retainer			
57	817 00 06-16	Screw Hexwsh Thd 3/8-16 x 1			
59	532 14 10-43	Guard, Tuv Idler (94)			
62	874 52 06-36	Bolt 3/8-16 unc x 2-1/4 Gr. 5			

NOTE: All component dimensions given in U.S. inches
1 inch = 25.4 mm

**TRACTOR -- MODEL NUMBER YTH22V46XLS (96043010301), PRODUCT NO. 960 43 01-03
MOWER LIFT**

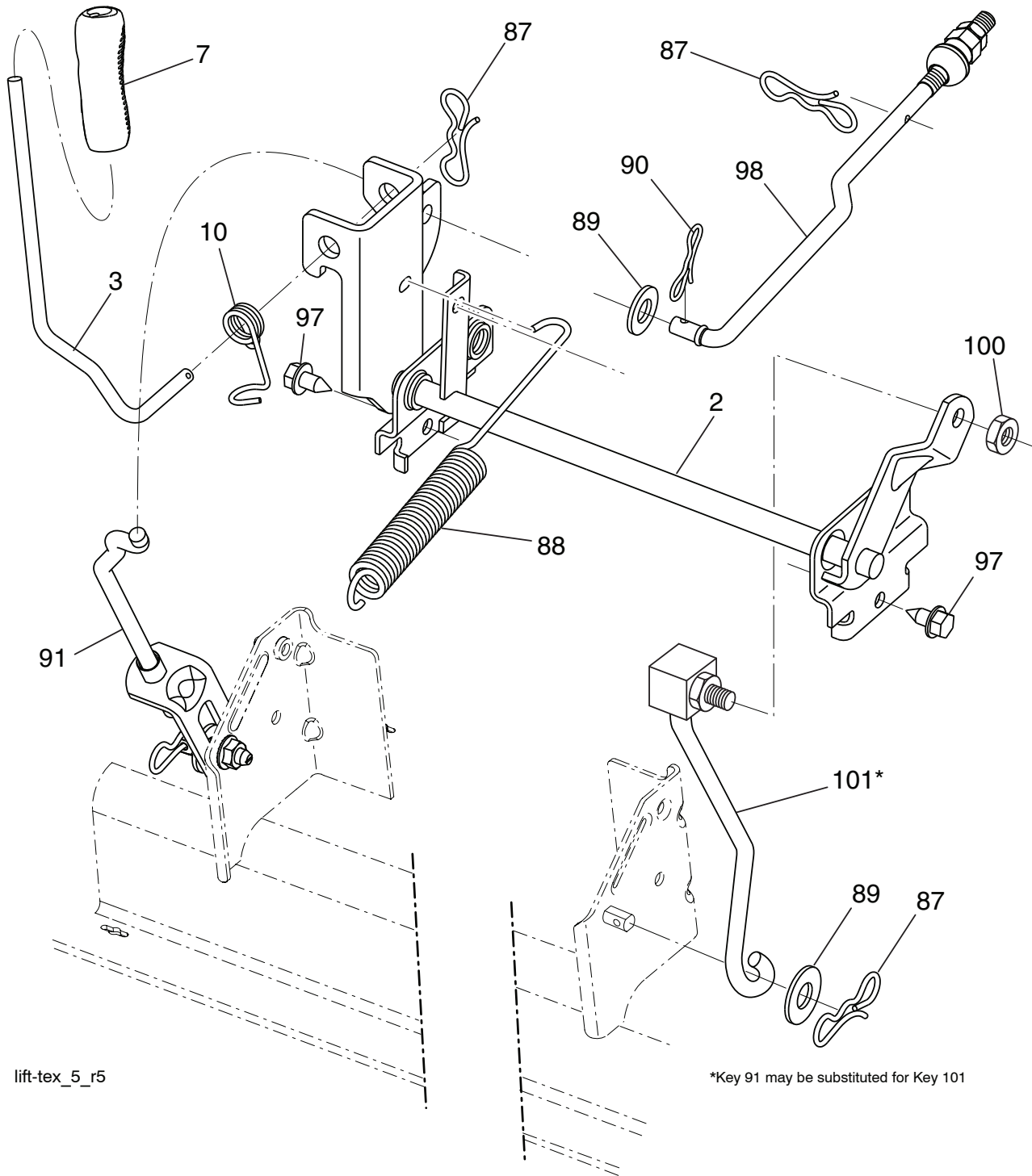

lift-tex_5_r5

*Key 91 may be substituted for Key 101

KEY NO.	PART NO.	DESCRIPTION
2	532 42 20-27	Shaft Asm., Lift
3	532 19 52-31	Lever Lift Handle
7	532 41 15-55	Grip, Lever
10	532 19 63-14	Spring Torsion
87	532 19 42-09	Pin Cotter 7/16 Bow Tie Lock
88	532 41 07-10	Spring Lift Assist
89	819 19 19-12	Washer Clear Zinc
90	532 19 42-08	Pin Cotter 5/16 Bow Tie Lock
91	532 19 51-81	Link Lift Susp Mower Rear

KEY NO.	PART NO.	DESCRIPTION
97	817 00 06-12	Screw 3/8-16 x 3/4
98	532 19 52-70	Link Asm. Susp. Front Mower
100	873 93 06-00	Nut Centerlock 3/8-16 unc
101	532 40 70-03	Link Lift Asm Fxd

NOTE: All component dimensions given in U.S. inches
1 inch = 25.4 mm

**TRACTOR -- MODEL NUMBER YTH22V46XLS (96043010301), PRODUCT NO. 960 43 01-03
SEAT ASSEMBLY**

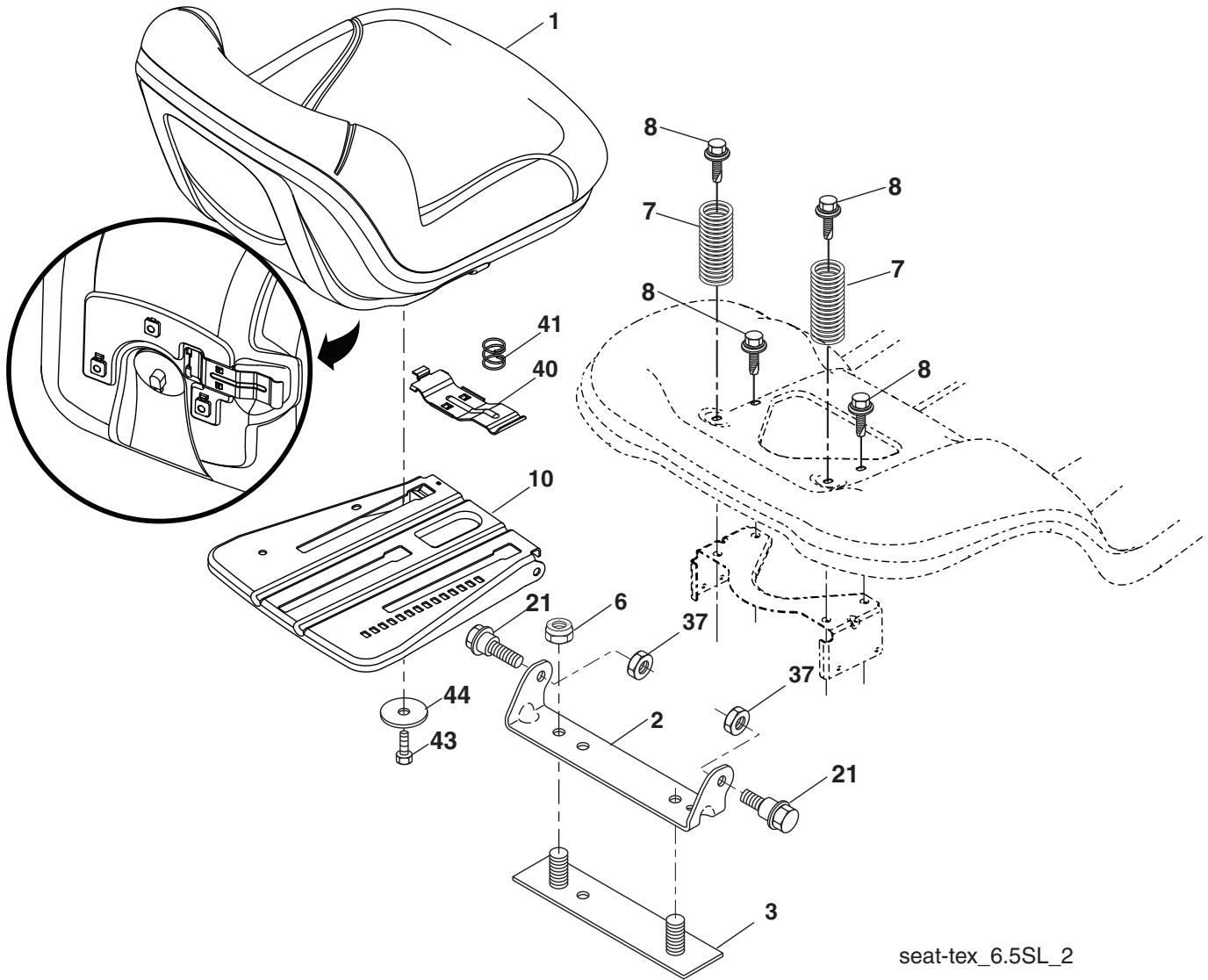

KEY NO.	PART NO.	DESCRIPTION
1	532 42 40-71	Seat
2	532 18 01-66	Bracket Pivot Fender
3	532 14 06-75	Strap, Asm Fender
6	873 80 06-00	Nut, Lock W/Ins. 3/8-16 unc
7	532 12 41-81	Spring, Seat Cprsn
8	532 17 18-77	Bolt 5/16-18 unc x 3/4 w/Sems
10	532 19 69-77	Pan, Seat
21	532 17 18-52	Bolt, Shoulder 5/16-18

KEY NO.	PART NO.	DESCRIPTION
37	873 80 05-00	Nut, Lock 5/16-18 unc
40	532 19 76-61	Handle Slide Seat
41	532 19 82-00	Spring Latch Seat
43	874 76 06-12	Bolt Fin Hex 3/8-16 unc x 3/4
44	819 13 38-12	Washer 13/32 x 2-3/8 x 12 Ga.

NOTE: All component dimensions given in U.S. inches
1 inch = 25.4 mm

**TRACTOR -- MODEL NUMBER YTH22V46XLS (96043010301), PRODUCT NO. 960 43 01-03
DECALS**

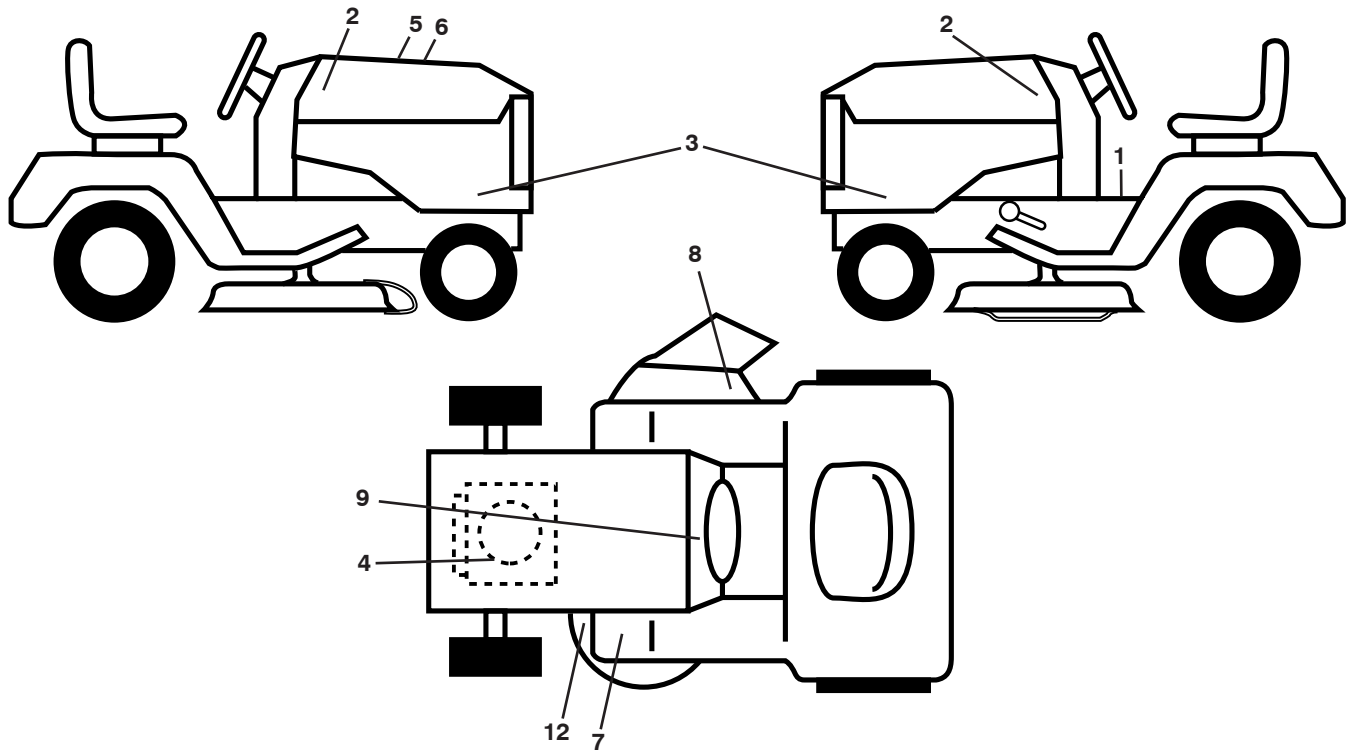

KEY NO.	PART NO.	DESCRIPTION
1	532 41 16-58	Decal, Operators
2	532 42 91-96	Decal, Badge
3	532 43 20-89	Decal, Panel SD
4	532 43 29-14	Decal, Eng. HP
5	532 42 38-29	Decal, Customer Respons.
6	532 43 20-83	Decal, Replacement
7	532 41 86-00	Decal, Pedal Husq. Crown
8	532 17 05-63	Decal Mower Warn Keep Handaway

KEY NO.	PART NO.	DESCRIPTION
9	532 14 50-05	Decal, Battery Dnge/Poi
12	532 16 03-96	Decal, Mower V-Belt Schematic
--	532 41 82-77	Decal, Deck Air Induct
--	532 16 69-60	Decal, Bypass
--	532 41 08-05	Pad, Footrest, LH
--	532 41 08-06	Pad, Footrest, RH
--	532 43 53-54	Manual, Owner's (English)
--	532 43 53-55	Manual, Owner's (French)

WHEELS AND TIRES

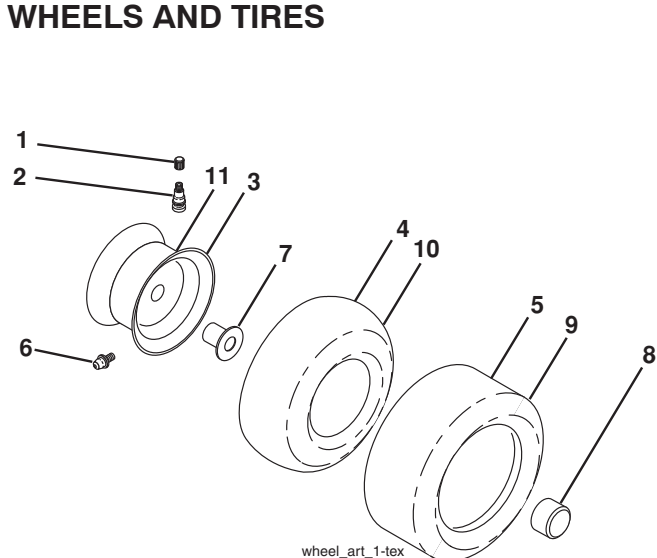

KEY NO.	PART NO.	DESCRIPTION
1	532 05 91-92	Cap Valve Tire
2	532 06 51-39	Stem Valve
3	532 13 83-36	Rim Front Service
4	532 05 99-04	Tube Front (Service Item Only)
5	532 10 62-22	Tire TM Front 15 x 6.00-6
6	532 12 49-57	Fitting Grease (Front Wheel Only)
7	532 12 49-59	Bearing Flange (Front Wheel Only)
8	532 17 50-39	Cap Axle Blk 1 50 x 1 00
9	532 13 84-68	Tire TM Rear 30 x 10.00-8
10	532 12 49-26	Tube Rear (Service Item Only)
11	532 13 83-37	Rim Asm 8" rear Service
--	532 14 43-34	Sealant, Tire (10 oz. Tube)

NOTE: All component dimensions given in U.S. inches
1 inch = 25.4 mm

SUGGESTED GUIDE FOR SIGHTING SLOPES FOR SAFE OPERATION

