

RYOBI 2.5 in. STRAIGHT FINISH NAILER - MODEL NUMBER YN250FS

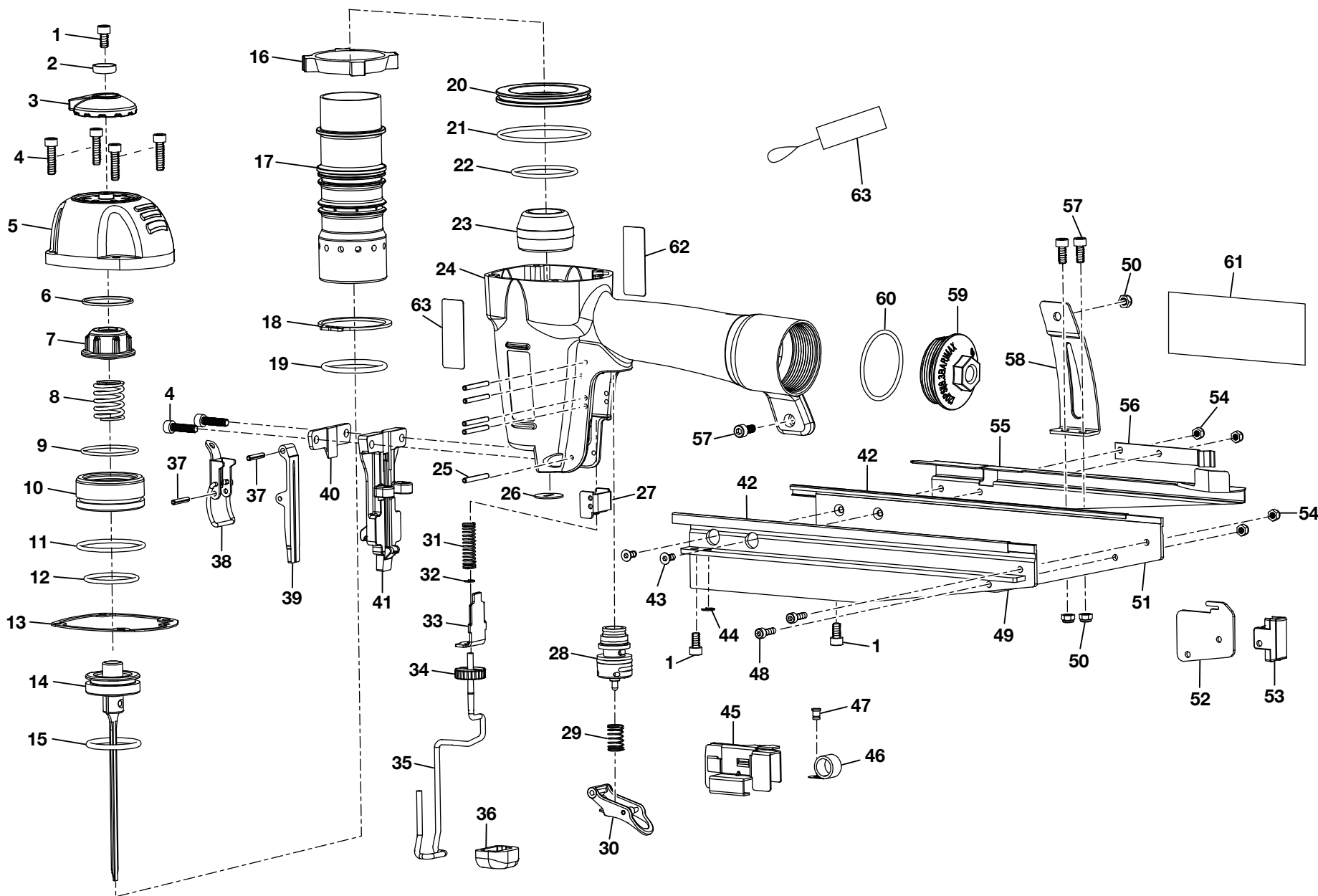

⚠ DANGER: Do not use oxygen, combustible gases or bottled gases as a power source for this tool. The tool will explode and cause death or serious injury.

⚠ WARNING: Disconnect the tool from the air supply before performing maintenance. Failure to do so could result in serious personal injury.

RYOBI 2.5 in. STRAIGHT FINISH NAILER - MODEL NUMBER YN250FS

KEY	P/N	DESCRIPTION	QTY	KEY	P/N	DESCRIPTION	QTY	KEY	P/N	DESCRIPTION	QTY
1	079023001050	*SCREW (M5 X 10 mm, HEX SOC. HD.) ..3		29	079023001029	SPRING	1	56	079025001047	SPRING PLATE.....	1
2	079025001001	WASHER, EXHAUST CAP.....	1	30	079023001701	TRIGGER UNIT.....	1	57	079025001048 *	SCREW (M5 X 12 mm, HEX SOC. HD.) ..3	
3	079025001002	EXHAUST CAP	1	31	079025001024	SPRING	1	58	079025001049	BRACKET	1
4	A07003050200	*SCREW (M5 X 20 mm, HEX SOC. HD.) ..6		32	079025001025	E-RING	1	59	079023001056	END CAP.....	1
5	079025001003	MAIN CAP	1	33	079025001026	WORK PIECE CONTACT B	1	60	079023001057	O-RING (AS568-132).....	1
6	079025001004	PISTON STOP WASHER.....	1	34	079025001027	ADJUSTING KNOB	1	61	079025001900	WARNING/SPEC LABEL.....	1
7	079025001005	PISTON STOP	1	35	079025001028	WORK PIECE CONTACT A	1	62	079025001901	LOGO LABEL	2
8	079025001006	SPRING, HEAD VALVE	1	36	079025001029	NON MAR NOSEPIECE.....	1	63	079023001064	HANG TAG	1
9	079025001007	O-RING (SM-36).....	1	37	079025001030	SPRING PIN (D3 x 18 mm).....	2		NOT SHOWN		
10	079025001008	HEAD VALVE	1	38	079025001031	QUICK RELEASE LATCH	1	64	079025001050	OVERHAUL MAINTENANCE KIT WITH AIR TOOL OIL AND INSTRUCTION SHEET (INC. KEY NOS. 9, 11, 12, 13, 15, 18,19, 21, 22, 23, 28).....	1
11	079025001009	O-RING (AS568-131).....	1	39	079025001032	LID NOSE PIECE	1				
12	079023001010	O-RING (AS568-125).....	1	40	079025001033	GASKET	1				
13	079025001010	CAP GASKET	1	41	079025001034	NOSE PIECE	1	65	079025001051	DRIVER MAINTENANCE KIT (INC. KEY NOS. 13, 14, 15, 23, INSTRUCTION SHEET & LUBRICANT)...	1
14	079025001011	DRIVER UNIT.....	1	42	079025001035	NAIL GUIDE.....	2				
15	079025001012	O-RING (P-31.5).....	1	43	079025001036 *	SCREW (M4 x 10 mm, HEX SOC. CAP)..2		66	079025001701	DRIVER ASSEMBLY KIT (INC. KEY NOS. 14, 15, INSTRUCTION SHEET & LUBRICANT).....	1
16	079025001013	SEAL.....	1	44	079025001037	E-RING	1				
17	079025001014	CYLINDER.....	1	45	079025001038	PUSHER.....	1				
18	079025001015	C-RING.....	1	46	079025001039	SPIRAL SPRING.....	1	67	079024001023	WRENCH KIT (INC. 3 mm, 4 mm HEX KEYS).....	1
19	079025001016	O-RING (P-39).....	1	47	079025001040	ROLL PIN	1				
20	079025001017	CYLINDER RING	1	48	079025001041 *	SCREW (M4 x 14 mm, HEX SOC. HD.)...2		68	079023001062	SAFETY GLASSES	1
21	079025001018	O-RING (AS568-142).....	1	49	079025001042	MAGAZINE A.....	1	69	079002001113	OIL.....	1
22	079025001019	O-RING (AS568-130).....	1	50	079024001008	NUT (M5)	3	70	079023001065	CARRY BAG.....	1
23	079025001020	BUMPER	1	51	079025001043	MAGAZINE B WITH WARNING/SPEC. LABEL	1	71	987000108	OPERATOR'S MANUAL	1
24	079025001053	TOOL BODY W/GRIP	1						01-02-08 (REV:01)		
25	079025001022	SPRING PIN (D3 x 28 mm).....	5	52	079025001044	SPACE HOLDER)	1				
26	079025001023	DRIVER GUIDE.....	1	53	079025001045	MAGAZINE END CAP	1				
27	079023001035	WORK PIECE CONTACT GUIDE.....	1	54	079023001049	SCREW NUT (M4)	4				
28	079025001700	TRIGGER VALVE ASSEMBLY	1	55	079025001046	HOLD DOWN	1				