

ELECTRIC TOOL PARTS LIST

■ SCREW DRIVER
Model W 6VB3SD2

2016 • 02 • 01
(E1)

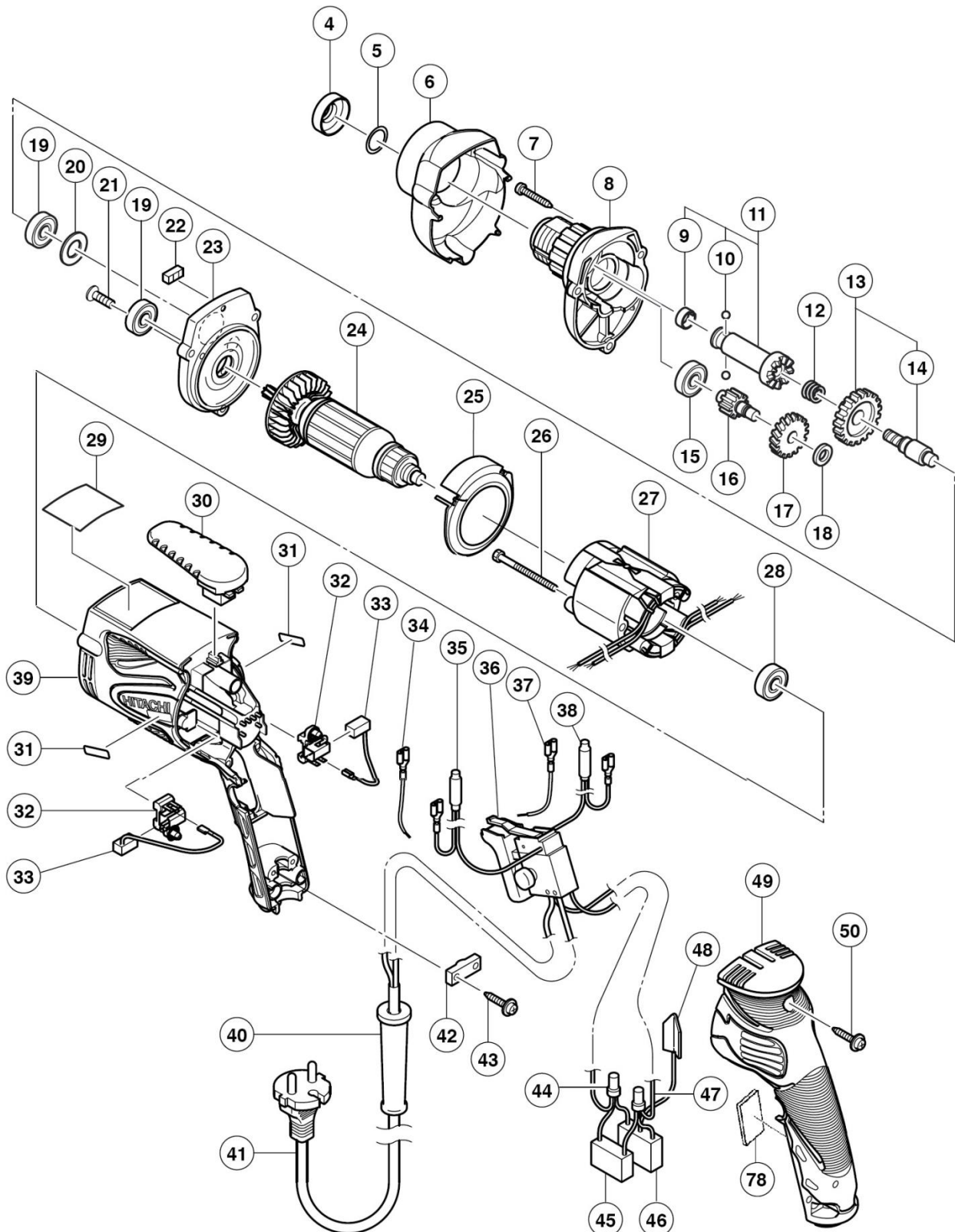

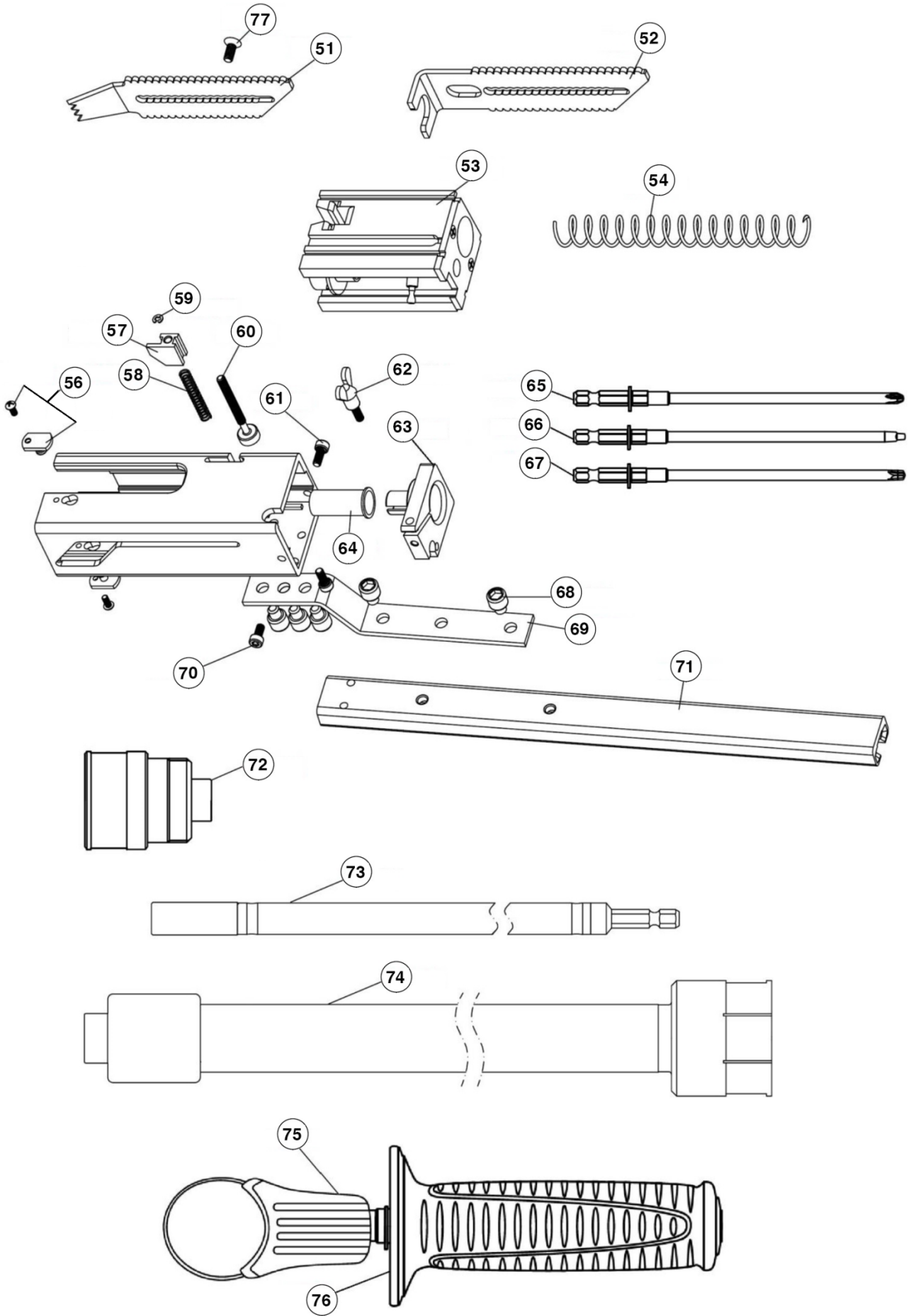

PARTS

W6VB3SD2

ITEM NO.	CODE NO.	DESCRIPTION	NO. USED	REMARKS
4	971468	FRINGER (A)	1	
5	317662	O-RING (F)	1	
6	323494	PROTECT COVER (B)	1	
7	321057	TAPPING SCREW D4X25 (BLACK)	3	
8	323498	GEAR COVER ASS'Y (B)	1	INCLUD.5.15
9	872573	SET RING	1	
10	959148	STEEL BALL D3.175 (10 PCS.)	2	
11	317664	SOCKET (B) ASS'Y	1	INCLUD.9.10
12	306024	SPRING	1	
13	317771	GEAR ASS'Y	1	INCLUD.14
14	307340	GEAR SHAFT	1	
15	608VVM	BALL BEARING 608VVC2PS2L	1	
16	317770	SECOND PINION ASS'Y	1	INCLUD.17
17	307337	FIRST GEAR	1	
18	323497	WASHER	1	
19	608VVM	BALL BEARING 608VVC2PS2L	2	
20	933545	WASHER (A)	1	
21	323556	SLOTTED HD. SCREW (SEAL LOCK) M4X8	2	
23A	323493	INNER COVER ASS'Y (A)	1	INCLUD.19-21
*24	360674	ARMATURE (D) 110V	1	
*24	360675U	ARMATURE ASS'Y (D) 120V	1	INCLUD.19.28
*24	360675E	ARMATURE (D) 220V-230V	1	
*24	360675F	ARMATURE (D) 240V	1	
25	323472	FAN GUIDE	1	
26	961672	HEX. HD. TAPPING SCREW D4X50	2	
*27	340599C	STATOR 110V-120V	1	
*27	340599E	STATOR 220V-240V	1	
28	608VVM	BALL BEARING 608VVC2PS2L	1	
29		NAME PLATE	1	
30	323471	HOOK	1	
31		HITACHI LABEL	2	
32	323512	BRUSH HOLDER (A)	2	
33	999091	CARBON BRUSH (AUTO STOP TYPE) (1 PAIR)	2	
34	323567	INTERNAL WIRE (BROWN)	1	FOR SAU
35	323566	CHOKE COIL (W/INTERNAL WIRE) BROWN	1	EXCEPT FOR SAU
36	323479	SWITCH (1P PILLAR TYPE) W/LOCK	1	
37	323569	INTERNAL WIRE (BLUE)	1	FOR SAU
38	323568	CHOKE COIL (W/INTERNAL WIRE) BLUE	1	EXCEPT FOR SAU
39A	326671	HOUSING	1	
40	953327	CORD ARMOR D8.8	1	
*41	323559	CORD (LENGTH 7.5M)	1	(CORD ARMOR D8.8)
*41	323562	CORD (LENGTH 7.5M)	1	(CORD ARMOR D8.8) FOR GBR (110V)
*41	323560	CORD (LENGTH 7.5M)	1	(CORD ARMOR D8.8) FOR GBR (230V)
*41	323561	CORD (LENGTH 7.5M)	1	(CORD ARMOR D8.8) FOR AUS
*41	320130	CORD (LENGTH 7.5M)	1	(CORD ARMOR D8.8) FOR USA.CAN
*41	500409Z	CORD	1	(CORD ARMOR D8.8) FOR SAU
*41	500487Z	CORD	1	(CORD ARMOR D8.8) FOR BRA
42	937631	CORD CLIP	1	
43	984750	TAPPING SCREW (W/FLANGE) D4X16	2	
44	959140	CONNECTOR 50091 (10 PCS.)	2	EXCEPT FOR USA.CAN.SAU
45	930039	NOISE SUPPRESSOR	1	EXCEPT FOR USA.CAN.SAU
46	994273	NOISE SUPPRESSOR	1	EXCEPT FOR USA.CAN.SAU
47	317667	INTERNAL WIRE	2	EXCEPT FOR USA.CAN.SAU
48	992635	EARTH TERMINAL	1	EXCEPT FOR USA.CAN.SAU
49A	326672	HANDLE COVER	1	
50	301653	TAPPING SCREW (W/FLANGE) D4X20 (BLACK)	3	
51	725470	NOSEPIECE SUBFLOOR AND METAL-TO-METAL	1	
52	725471	NOSEPIECE DECK/DRYWALL	1	
53	725414	MODULE (GREEN DOT)	1	
54	725415	SPRING (GREEN) 1.7MM	1	

