

## ELECTRIC TOOL PARTS LIST

■ SCREW DRIVER  
Model W 6V4

2004 · 8 · 30  
(E1)

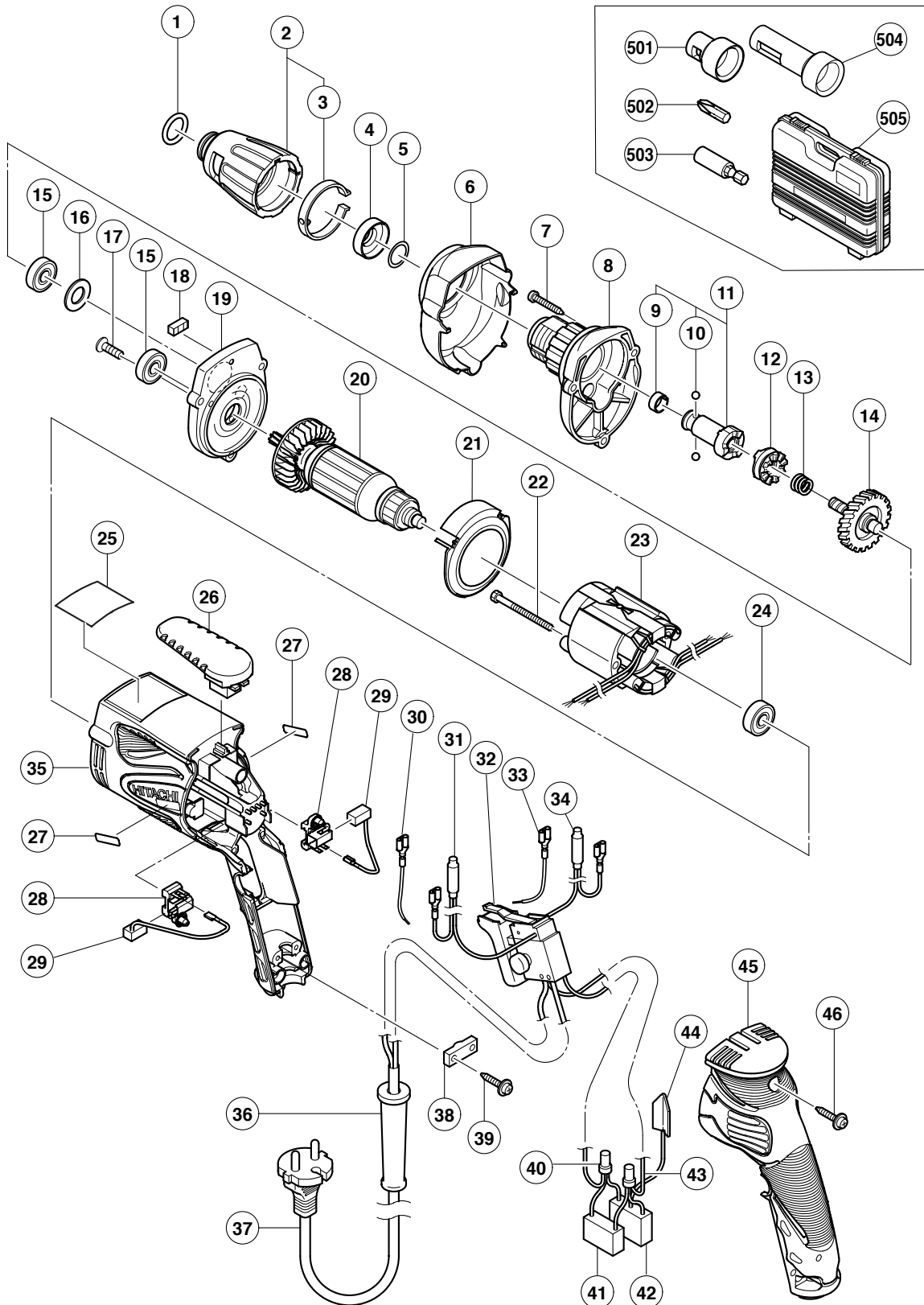

**PARTS**

W 6V4

ITEM NO.	CODE NO.	DESCRIPTION	NO. USED	REMARKS
1	876-031	O-RING (S-16)	1	
2	323-487	LOCATOR ASS'Y	1	INCLUD. 3
3	323-488	CLICK SPRING	1	
4	971-468	FRINGER (A)	1	
5	317-662	O-RING (F)	1	
6	323-558	PROTECT COVER (A)	1	
7	321-057	TAPPING SCREW D4X25 (BLACK)	3	
8	323-486	GEAR COVER (A) ASS'Y	1	INCLUD. 5
9	872-573	SET RING	1	
10	959-148	STEEL BALL D3.175 (10 PCS.)	2	
* 11	323-491	SOCKET (A) ASS'Y	1	INCLUD. 9, 10
* 11	323-482	SOCKET (A) ASS'Y	1	INCLUD. 9, 10 FOR TPE, THA, HKG, KOR
12	323-476	CLUTCH DISC	1	
13	306-024	SPRING	1	
14	323-485	GEAR SET	1	
15	608-VVM	BALL BEARING 608VVC2PS2L	2	
16	933-545	WASHER (A)	1	
17	323-556	SLOTTED HD. SCREW (SEAL LOCK) M4X8	2	
18	323-557	FELT (A)	1	
19	323-473	INNER COVER ASS'Y (A)	1	INCLUD. 15-18
* 20	360-672	ARMATURE (A) 110V	1	
* 20	360-673U	ARMATURE ASS'Y (A) 120V	1	INCLUD. 15, 24
* 20	360-673E	ARMATURE (A) 220V-230V	1	
* 20	360-673F	ARMATURE (A) 240V	1	
21	323-472	FAN GUIDE	1	
22	961-672	HEX. HD. TAPPING SCREW D4X50	2	
* 23	340-599C	STATOR 110V-120V	1	
* 23	340-599E	STATOR 220V-240V	1	
24	608-VVM	BALL BEARING 608VVC2PS2L	1	
25		NAME PLATE	1	
26	323-471	HOOK	1	
27		HITACHI LABEL	2	
28	323-512	BRUSH HOLDER (A)	2	
29	999-091	CARBON BRUSH (AUTO STOP TYPE) (1 PAIR)	2	
* 30	323-489	INTERNAL WIRE (BROWN)	1	FOR THA, HKG, KUW, USA, CAN
* 31	323-480	CHOKE COIL (W/INTERNAL WIRE) BROWN	1	EXCEPT FOR THA, HKG, KUW, USA, CAN
32	323-479	SWITCH (1P PILLAR TYPE) W/LOCK	1	
* 33	323-490	INTERNAL WIRE (BLUE)	1	FOR THA, HKG, KUW, USA, CAN
* 34	323-481	CHOKE COIL (W/INTERNAL WIRE) BLUE	1	EXCEPT FOR THA, HKG, KUW, USA, CAN
35	323-483	HOUSING	1	
36	953-327	CORD ARMOR D8.8	1	
* 37	323-559	CORD (LENGTH 7.5M)	1	(CORD ARMOR D8.8)
* 37	500-468Z	CORD	1	(CORD ARMOR D8.8) FOR THA
* 37	500-423Z	CORD	1	(CORD ARMOR D8.8) FOR KUW
* 37	320-130	CORD (LENGTH 7.5M)	1	(CORD ARMOR D8.8) FOR USA, CAN
* 37	500-435Z	CORD	1	(CORD ARMOR D8.8) FOR HKG
* 37	500-409Z	CORD	1	(CORD ARMOR D8.8) FOR KOR
* 37	500-470Z	CORD	1	(CORD ARMOR D8.8) FOR TPE
* 37	323-561	CORD (LENGTH 7.5M)	1	(CORD ARMOR D8.8) FOR AUS
* 37	323-562	CORD (LENGTH 7.5M)	1	(CORD ARMOR D8.8) FOR GBR (110V)
* 37	323-560	CORD (LENGTH 7.5M)	1	(CORD ARMOR D8.8) FOR GBR (230V)



## STANDARD ACCESSORIES

W 6V4

ITEM NO.	CODE NO.	DESCRIPTION	NO. USED	REMARKS
* 501	323-352	SUB STOPPER (G)	1	EXCEPT FOR HKG, AUS, HOL, USA, CAN
502	971-511Z	+ DRIVER BIT (A) NO. 2 25L	1	
* 503	317-674	MAGNETIC BIT HOLDER ASS'Y (41L)	1	INCLUD. 502
* 503	323-354	MAGNETIC BIT HOLDER ASS'Y (47.1L)	1	INCLUD. 502 FOR TPE, THA, KOR
* 503	982-554Z	MAGNETIC BIT HOLDER (75L)	1	FOR AUS, HOL, USA, CAN
* 503	323-353	MAGNETIC BIT HOLDER ASS'Y (81.1L)	1	INCLUD. 502 FOR HKG
* 504	323-351	SUB STOPPER (F)	1	FOR HKG, AUS, HOL, USA, CAN
* 505	310-904	CASE	1	FOR ESP

## OPTIONAL ACCESSORIES

ITEM NO.	CODE NO.	DESCRIPTION	NO. USED	REMARKS
601	317-670	SUB STOPPER (B) FOR H3/8, H10 HEX. SOCKET	1	
602	317-671	SUB STOPPER (B) FOR H5/16 HEX. SOCKET	1	
603	317-827	SUB STOPPER (B) H1/4 HEX. SOCKET	1	
* 604	985-330	MAGNETIC HEX. SOCKET 3/8"X65L	1	EXCEPT FOR TPE, THA, HKG, KOR
* 605	985-321	MAGNETIC HEX. SOCKET 10MMX65L	1	EXCEPT FOR TPE, THA, HKG, KOR
* 606	985-322	MAGNETIC HEX. SOCKET 5/16"X65L	1	EXCEPT FOR TPE, THA, HKG, KOR
* 607	985-332	MAGNETIC HEX. SOCKET 1/4"X65L	1	EXCEPT FOR TPE, THA, HKG, KOR
* 608	985-326	NON-MAGNETIC HEX. SOCKET 3/8" 65L	1	EXCEPT FOR TPE, THA, HKG, KOR
* 609	985-329	NON-MAGNETIC HEX. SOCKET 10MM 65L	1	EXCEPT FOR TPE, THA, HKG, KOR
* 610	985-327	NON-MAGNETIC HEX. SOCKET 5/16" 65L	1	EXCEPT FOR TPE, THA, HKG, KOR
* 611	985-328	NON-MAGNETIC HEX. SOCKET 1/4" 65L	1	EXCEPT FOR TPE, THA, HKG, KOR
* 612	982-563Z	NON-MAGNETIC BIT HOLDER	1	EXCEPT FOR TPE, THA, HKG, KOR
* 613	323-355	MAGNETIC HEX. SOCKET 10MMX71.1L	1	FOR TPE, THA, HKG, KOR
* 614	323-356	MAGNETIC HEX. SOCKET 5/16"X71.1L	1	FOR TPE, THA, HKG, KOR
615	985-333	+ DRIVER BIT NO. 1 25L	1	
616	971-512Z	+ DRIVER BIT (A) NO. 3 25L	1	
617	985-334	+ DRIVER BIT NO. 1 25L W/STEPPED ROD	1	
618	985-335	+ DRIVER BIT NO. 2 25L W/STEPPED ROD	1	
619	985-336	- DRIVER BIT 4MMX25	1	
620	985-337	- DRIVER BIT 5MMX25	1	
621	985-338	- DRIVER BIT 6MMX25	1	
622	985-339	- DRIVER BIT 8MMX25	1	
623	985-340	- DRIVER BIT 4MMX25 (W/STEPPED ROD)	1	
624	985-341	- DRIVER BIT 5MMX25 (W/STEPPED ROD)	1	
625	985-342	HEX. BIT 4MMX25L	1	
626	985-343	HEX. BIT 5MMX25L	1	
627	985-344	HEX. BIT 6MMX25L	1	
628	310-904	CASE	1	