

Tanaka Illustrated Parts Manual

Model Number:

TPE-260PF

PORTABLE EDGER

P/N 40814

Rev 000

Date 9-4-07



Nikko Tanaka Engineering U.S.A.,Ltd. • 1028 4th Street SW, Bldg B • Auburn, WA 98001 • Phone: (253) 333-1200 • Fax: (253) 333-1212

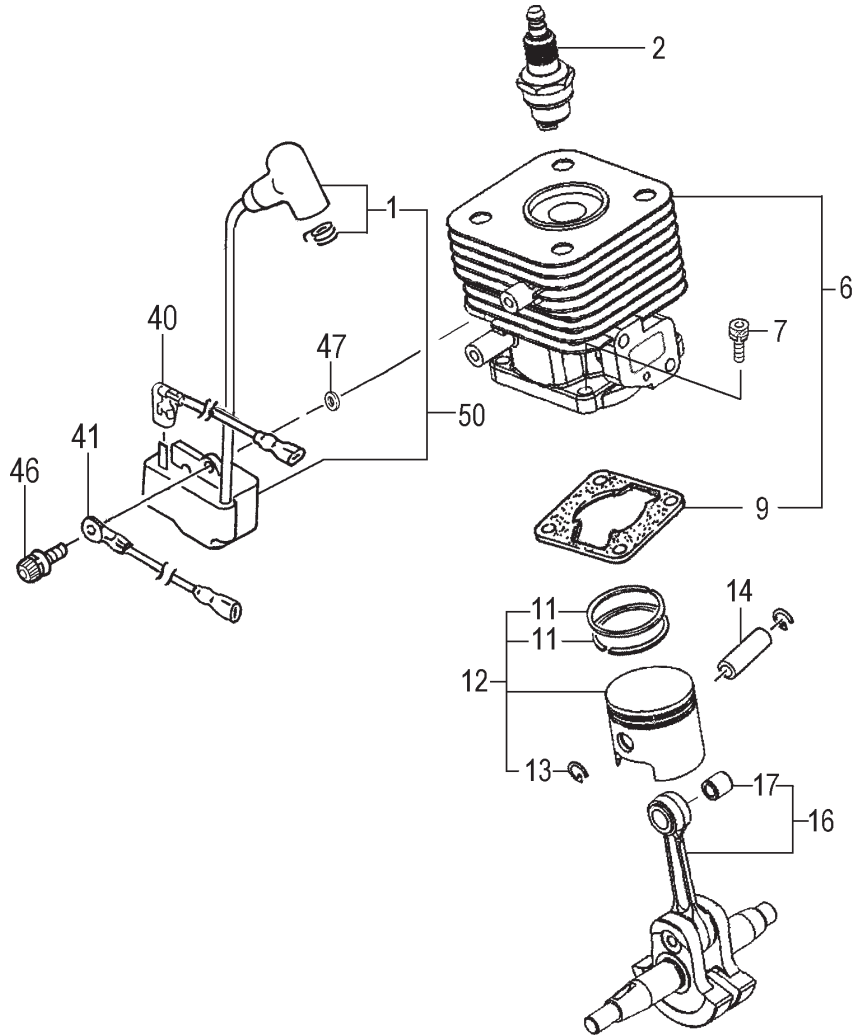

ITEM	PART NUMBER	DESCRIPTION	QTY	COMMENTS
1-1	1570168090	CAP, SPARK PLUG ASS'Y	1	
1-2	01802233200	PLUG, SPARK	1	
1-6	0010760090	CYLINDER SET	1	Includes gasket
1-7	99461050184	BOLT, HEX, 5X18, S	4	
1-9	0170735020	GASKET, CYLINDER	1	
1-11	04101601200	RING, PISTON	2	
1-12	0300750090	PISTON SET	1	Includes rings and circlips
1-13	03901620200	CIRCLIP, PISTON PIN	2	
1-14	0370704520	PIN, PISTON	1	
1-16	0460735082	CRANKSHAFT	1	
1-17	99962081225	BEARING, NEEDLE, F-810	1	
1-40	1780168080	CORD, STOP	1	
1-41	2740168080	CORD, EARTH	1	
1-46	99464040184	BOLT, HEX 4x18WS	2	
1-47	1820186A201	WASHER, SPECIAL	2	
1-50	1672101290	COIL, IGNITION	1	

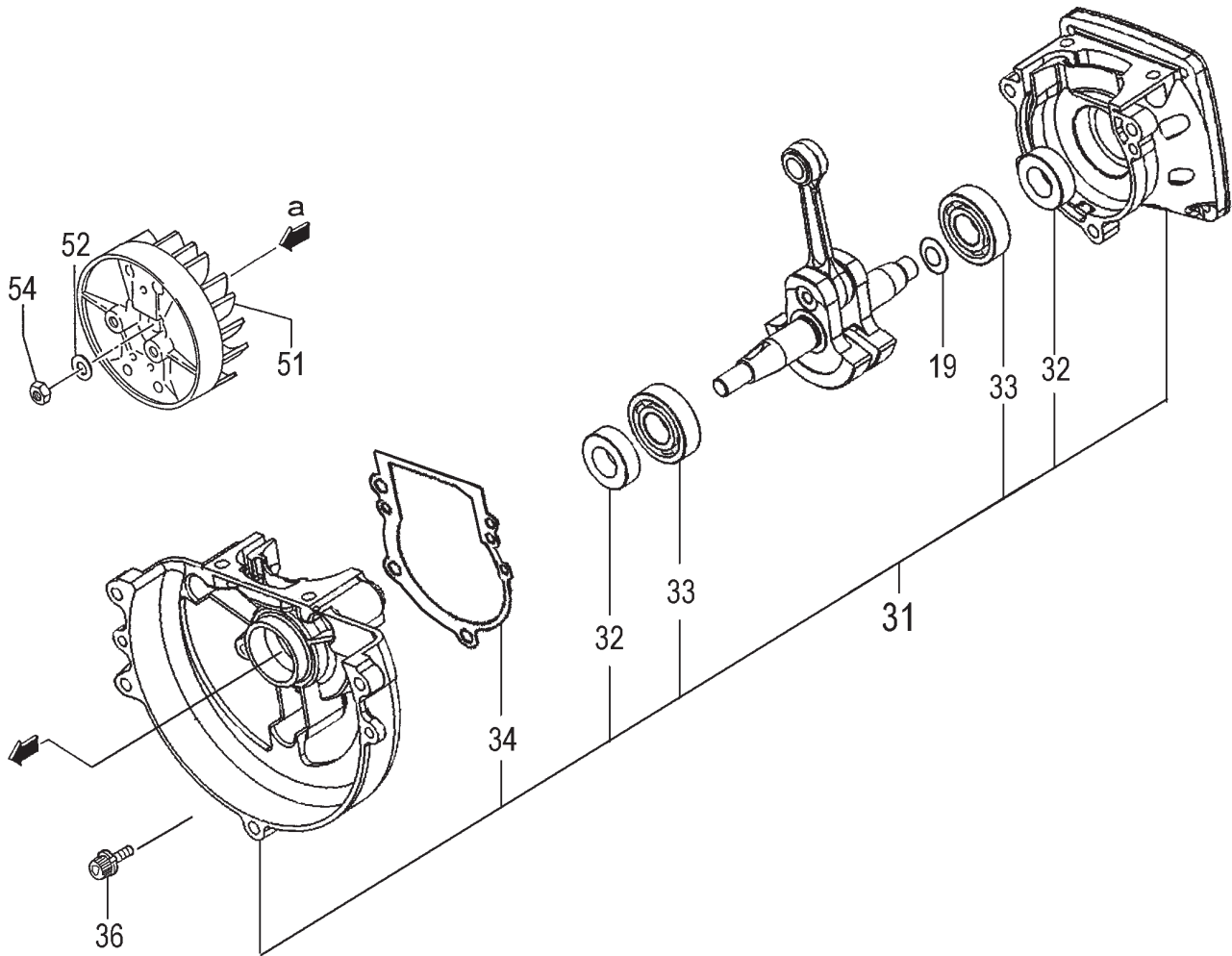

ITEM	PART NUMBER	DESCRIPTION	QTY	COMMENTS
2-19	33000200230	SHIM,12.2X19X.20	1	Includes bearings, seals and gasket
2-19	33000200240	SHIM,12.2X19X.30	1	
2-31	0720304592	CRANKCASE ASSY	1	
2-32	99966122206	SEAL,OIL,#TC12227	2	
2-33	99961600115	BEARING,BALL,6001 C3	2	
2-34	0900735022	GASKET,CRANKCASE	1	
2-36	99461050164	BOLT,HEX,5X16,S	4	
2-51	1552101281	FLYWHEEL	1	
2-52	99201080011	WASHER,8	1	
2-54	99101080011	NUT,8	1	

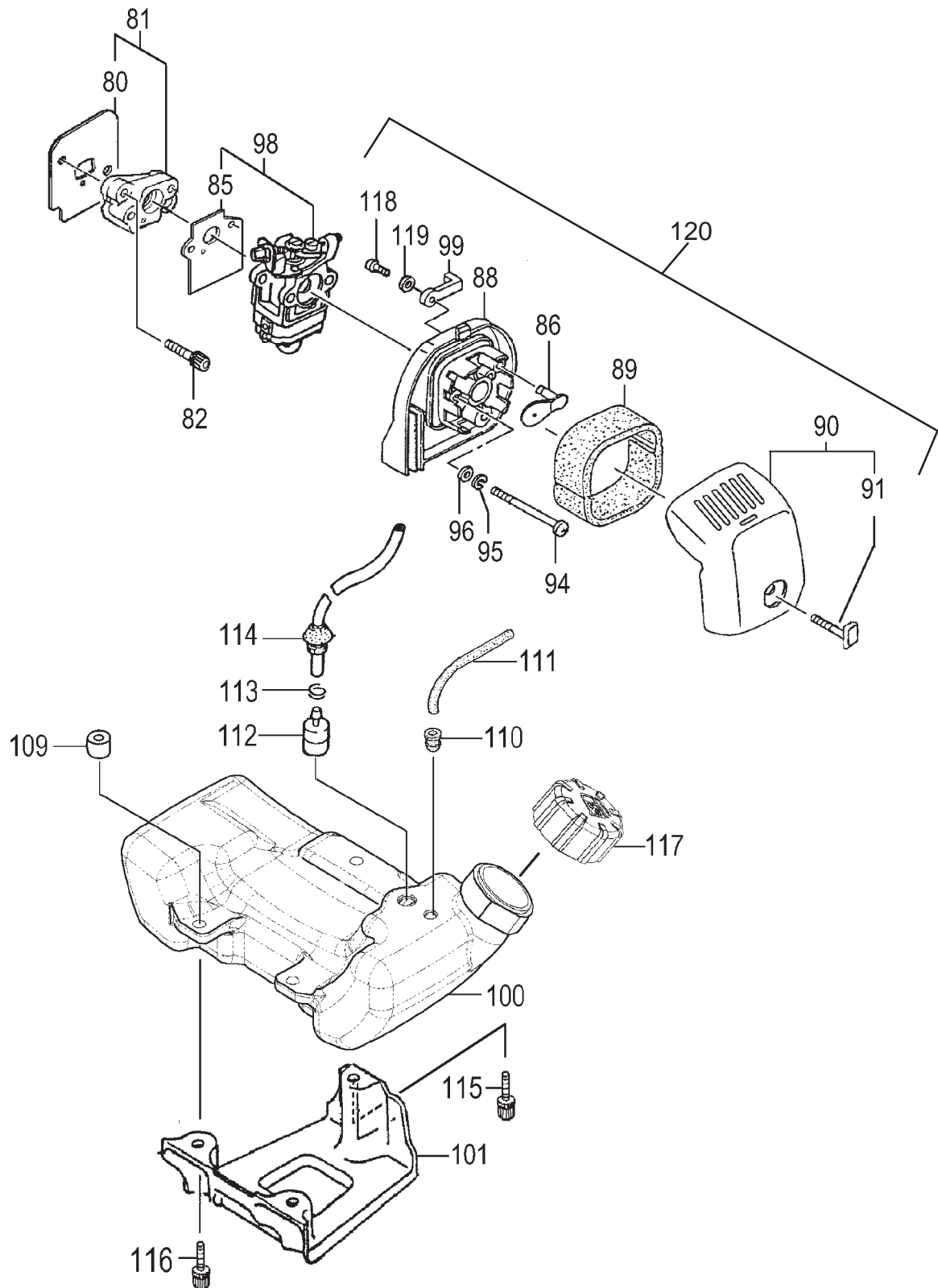

ITEM	PART NUMBER	DESCRIPTION	QTY	COMMENTS
3-80	4030702021	GASKET,INLET MANIFOLD	1	Includes gasket
3-81	4040702091	INSULATOR SET	1	
3-82	99464050255	BOLT,HEX,5x25WS	2	
3-85	4020656A200	GASKET	1	
3-86	5280652N22	PLATE,CHOKE,2.0	1	
3-88	4230652N80	BODY,AIR CLEANER	1	
3-89	4460652N20	CLEANER,ELEMENT	1	
3-90	4520304690	COVER,AIR CLEANER ASSY	1	
3-91	4500702480	BOLT,CLEANER COVER	1	
3-94	99011050552	SCREW,5X55	2	Includes gasket
3-95	99210050012	WASHER,S,5	2	
3-96	99200050011	WASHER,SMALL,5	2	
3-98	4550304590	CARBURETOR SET	1	
3-99	5230652N20	LEVER,CHOKE	1	
3-100	5910735F20	TANK,FUEL,EVAPO	1	
3-101	9400735020	STAND	1	
3-109	6590430020	COLLAR,C	3	
3-110	53432710200	GROMMET,FUEL PIPE	1	
3-111	70003005062	PIPE,FUEL,3X5X62	1	
3-112	6750404280	FILTER,FUEL	1	
3-113	68000731201	CLIP 6.3	1	
3-114	2230162V900	PIPE,FUEL,ASS'Y	1	
3-115	99464050255	BOLT,HEX,5x25WS	1	
3-116	99463050204	BOLT,HEX 5X20	2	
3-117	5950300290	CAP,TANK (BLACK/RED)	1	
3-118	99075040154	SCREW,TAPPING,4X15	1	
3-119	99201040011	WASHER,4	1	
3-120	4100304690	AIR CLEANER ASS'Y	1	

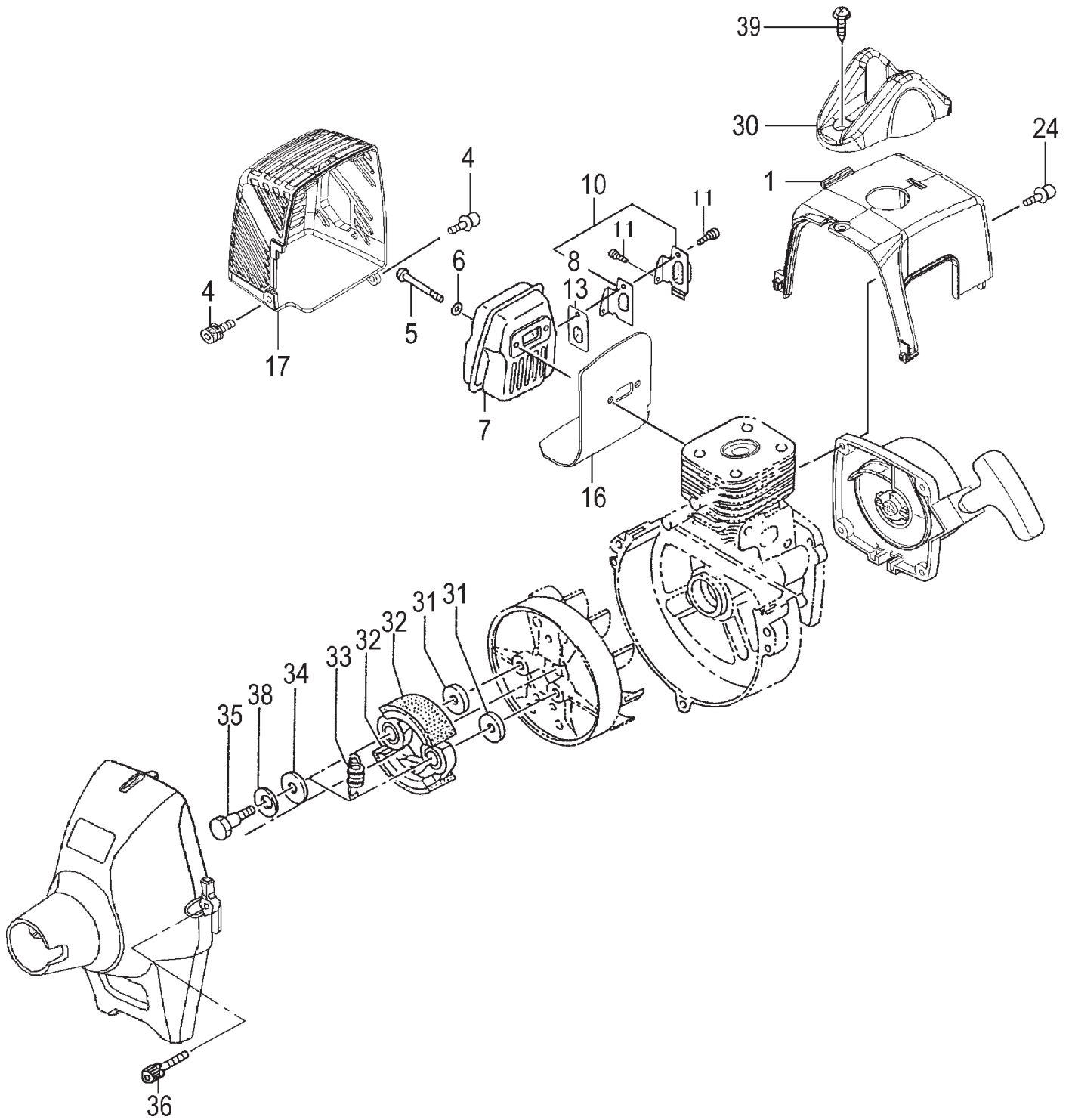

ITEM	PART NUMBER	DESCRIPTION	QTY	COMMENTS
4-1	0160750020	COVER,CYLINDER	1	
4-4	99463050164	BOLT,HEX,5X16,PS	2	
4-5	99051060653	BOLT,HEX,6x65	2	
4-6	99201060011	WASHER,6	2	
4-7	7060750080	MUFFLER	1	
4-8	7510725020	GASKET,MUFFLER	1	
4-10	7340725090	TAIL PIPE	1	
4-11	99436040081	SCREW,4X18WS	2	
4-13	7320725020	ARRESTER,SPARK	1	
4-16	1330750020	SHIELD,HEAT	1	
4-17	7380750020	COVER,MUFFLER	1	
4-24	99464040185	BOLT,HEX,4x18WS	2	
4-30	2570304520	PROTECTOR,SPARK PLUG	1	
4-31	35902103200	WASHER,CLUTCH,B	2	
4-32	29001620800	SHOE,CLUTCH	2	
4-33	3420630B200	SPRING,CLUTCH	1	
4-34	3480630A20	PLATE,CLUTCH	2	
4-35	3570075T200	BOLT,STEP	2	
4-36	99463050204	BOLT,HEX 5X20	3	
4-38	99205080030	WASHER,8	2	
4-39	99072045164	SCREW,TAPPING,4.5X16	1	

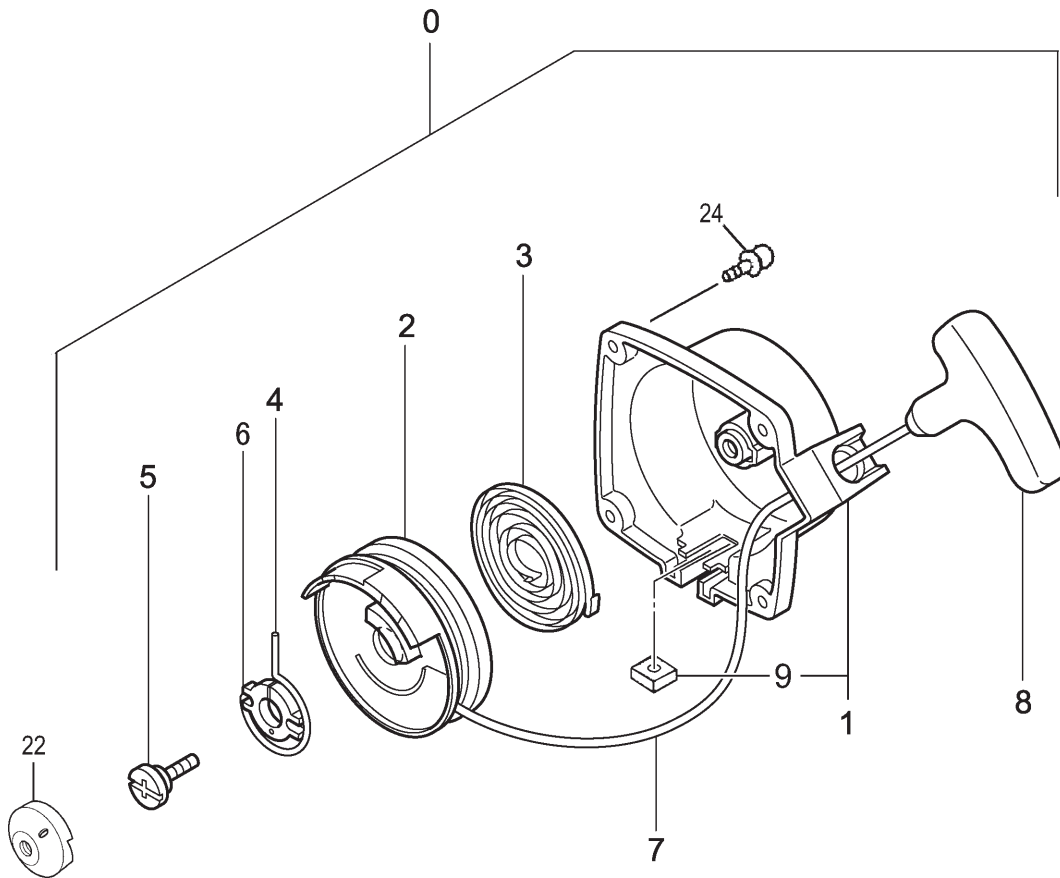

ITEM	PART NUMBER	DESCRIPTION	QTY	COMMENTS
5-0	7620304590	STARTER ASS'Y	1	
5-1	7720304580	BODY,STARTER	1	
5-2	7740304520	PULLEY,STARTER	1	
5-3	7790304520	SPRING,RECOIL	1	
5-4	7770304520	ARM,SWING	1	
5-5	8390304520	SCREW,SET	1	
5-6	7710304520	STAY,PULLEY	1	
5-7	7830304520	ROPE,STARTER	1	
5-8	7850304520	HANDLE,STARTER	1	
5-22	7980304520	PULLEY,STARTER	1	
5-24	99464040185	BOLT,HEX,4x18WS	2	

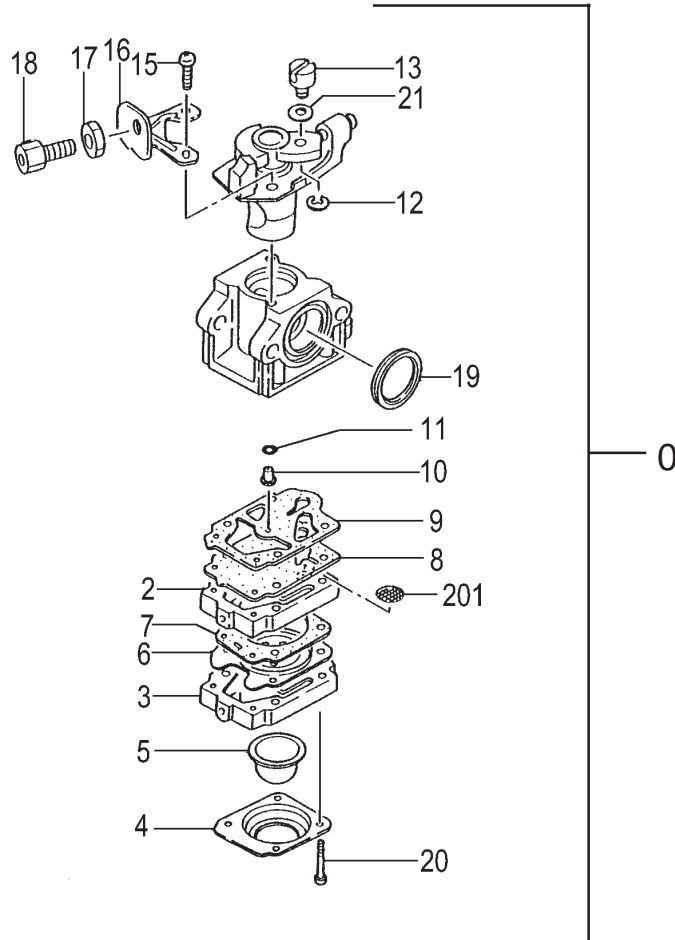

ITEM	PART NUMBER	DESCRIPTION	QTY	COMMENTS
6-0	4550304590	CARBURETOR SET	1	Includes gasket
6-2	5752515380	BODY,PUMP	1	
6-3	4422515180	PUMP,PRIMING	1	
6-4	4762515120	COVER,DIAPHRAGM	1	
6-5	44725108200	BULB,PRIMING	1	
6-6	~ ~ ~	DIAPHRAGM,METERING	1	Included in Carb Kit #650.25124.90
6-7	~ ~ ~	GASKET,DIAPHRAGM	1	(items not available individually)
6-8	~ ~ ~	DIAPHRAGM,PUMP	1	
6-9	~ ~ ~	GASKET,PUMP	1	
6-10	5992001W38	JET,MAIN LONG #38	1	
6-11	55025100200	O-RING	1	
6-12	48925100200	RING,STOP	1	
6-13	53925120200	SWIVEL	1	
6-15	51425100200	SCREW,THROTTLE SET	2	
6-16	54425164200	STAY,ADJUST,CABLE	1	
6-17	99101060013	NUT,6	1	
6-18	61425137200	ADJUSTER,CABLE	1	
6-19	4310634C200	GASKET,CLEANER	1	
6-20	5482515120	SCREW,SET	4	
6-21	5492516520	WASHER,THRUST	1	
6-201	57825007200	SCREEN,INLET	1	

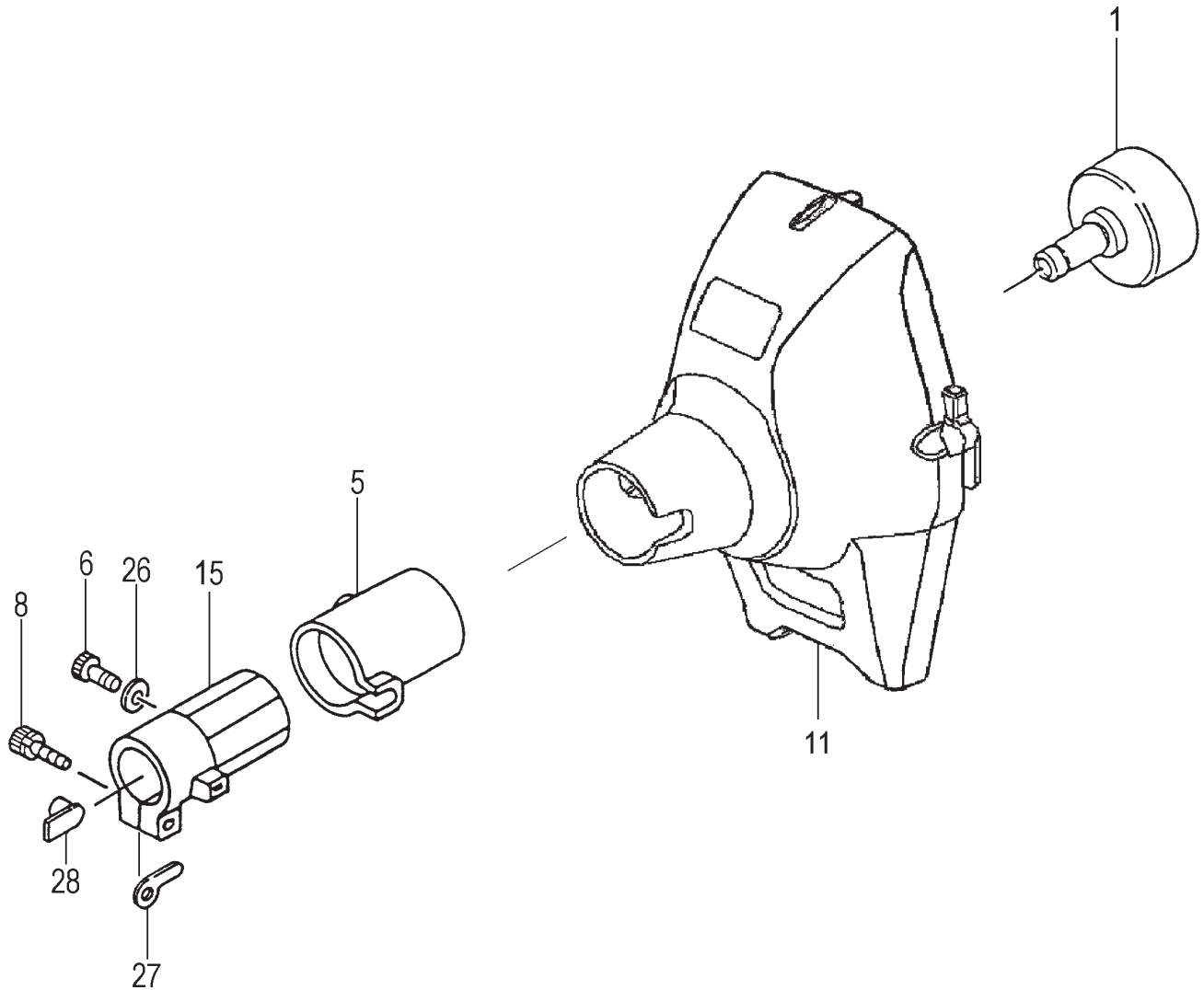

ITEM	PART NUMBER	DESCRIPTION	QTY	COMMENTS
7-1	2890750380	SHAFT, CLUTCH	1	
7-5	5990098021	CUSHION, RUBBER	1	
7-6	99051050163	BOLT, HEX, 5X16	1	
7-8	99461050254	BOLT, HEX HOLE, 5X25S	1	
7-11	1120304580	CASE, FAN	1	
7-15	3600099620	PIPE HOLDER	1	
7-26	99201050061	WASHER, 5	1	
7-27	3243735020	WASHER, GEAR CASE	1	
7-28	3610099020	FITTING, METAL	1	

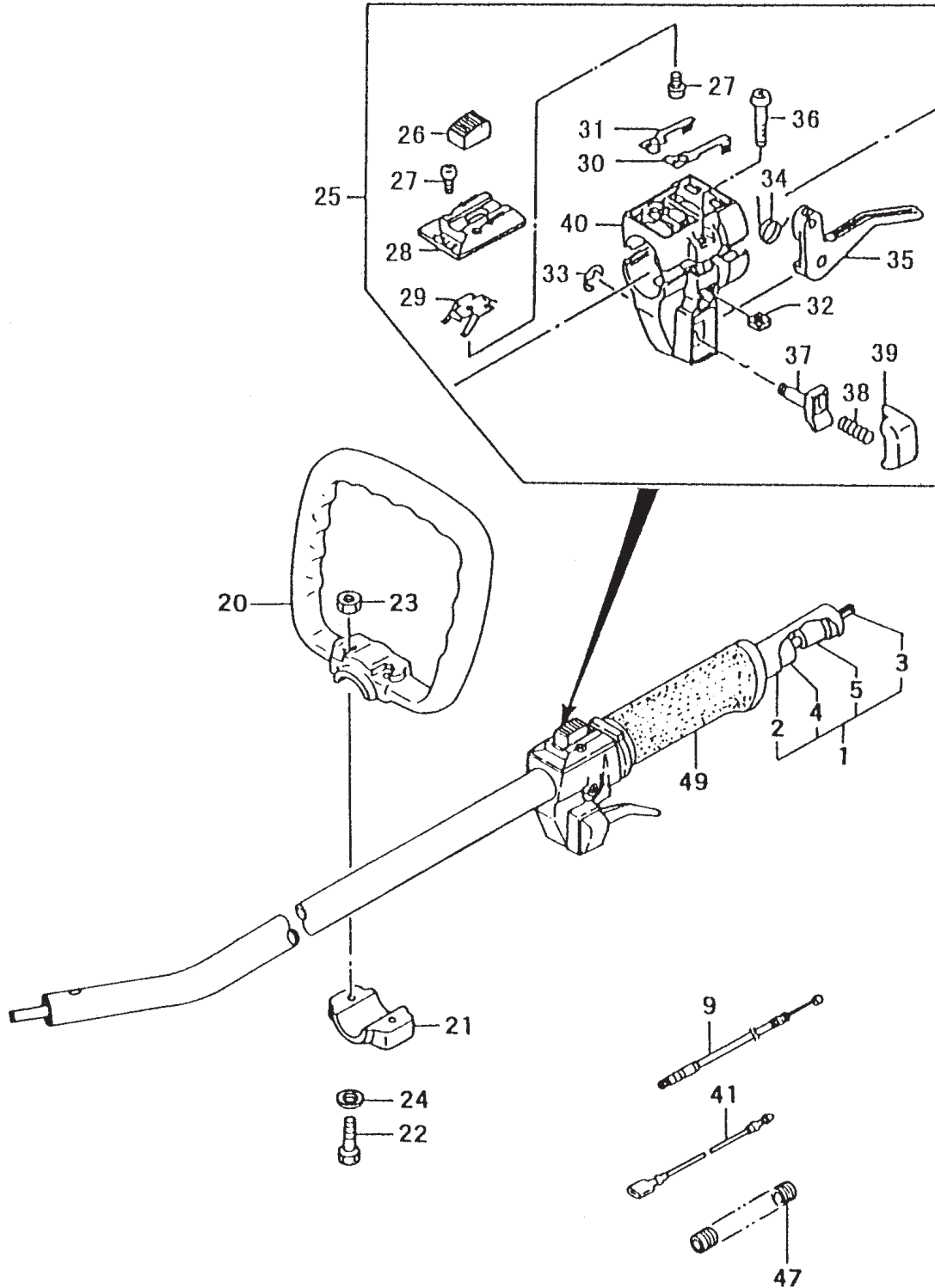

ITEM	PART NUMBER	DESCRIPTION	QTY	COMMENTS
8-1	3533729090	SET,DRIVE SHAFT PIPE	1	
8-2	3413729020	PIPE,DRIVE SHAFT	1	
8-3	3443729020	SHAFT,FLEXIBLE	1	
8-4	3503729020	LINER,FLEXIBLE	1	
8-5	3203729020	SPACER	1	
8-9	8853739480	WIRE,THROTTLE	1	
8-20	5003331620	HANDLE	1	
8-21	50633316200	BRACKET,HANDLE A	1	
8-22	99023060401	BOLT,P,6X40	2	
8-23	99101060011	NUT,6	2	
8-24	99201060011	WASHER,6	2	
8-25	8703728690	LEVER,THROTTLE ASS'Y	1	
8-26	1623710120	SWITCH,STOP	1	
8-27	99342030081	SCREW,TAPPING,3X8	3	
8-28	25937101200	BASE,STOP SWITCH	1	
8-29	26237101200	SPRING,STOP SWITCH	1	
8-30	17737101200	TERMINAL,EARTH B	1	
8-31	17637101200	TERMINAL,EARTH A	1	
8-32	3153334020	NUT,SPECIAL 5MM	1	
8-33	99355060001	RING,STOP,6	1	
8-34	83237101200	SPRING,RETURN	1	
8-35	8803728620	ARM,THROTTLE	1	
8-36	99431050201	SCREW,5X20	2	
8-37	85337101200	SHAFT,LOCK BUTTON	1	
8-38	95837101200	SPRING,LOCK,BUTTON	1	
8-39	95637101200	BUTTON,LOCK	1	
8-40	2603331720	BODY,STOP BUTTON,B	1	
8-41	1783739480	CORD,STOP 430mm	2	
8-47	1641001900	TUBE,PROTECTION,10X190	1	
8-49	50437300200	GRIP,SHAFT	1	

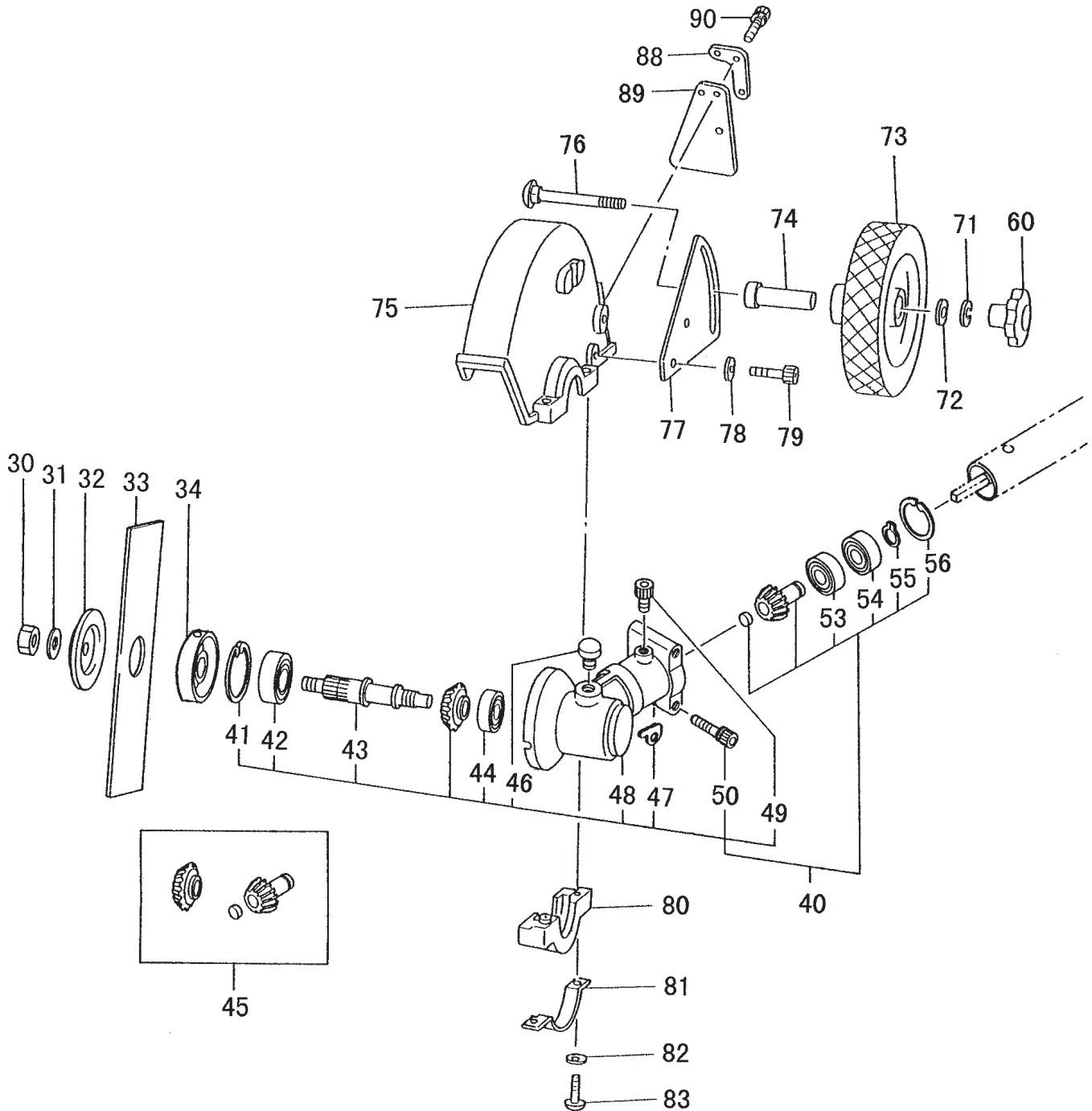

ITEM	PART NUMBER	DESCRIPTION	QTY	COMMENTS
9-30	99106080001	NUT,8/L.H.	1	
9-31	99201080011	WASHER,8	1	
9-32	3113729020	CAP,CUTTER HOLDER	1	
9-33	4353729020	BLADE,TPE-250	1	
9-34	3103729022	HOLDER,CUTTER	1	
9-40	3003729090	CASE,GEAR,ASSY	1	
9-41	99351032002	RING,STOP,C-32 IN	1	
9-42	99961620103	BEARING,BALL #6201D	1	
9-43	3043729020	SHAFT,GEAR	1	
9-44	99961628000	BEARING,BALL,#628	1	
9-45	3013729000	SET,GEAR/PINION	1	
9-46	99423080100	BOLT,8X10	1	
9-47	32433410201	WASHER,GEAR CASE	1	
9-48	3003729021	CASE,GEAR	1	
9-49	99051050103	BOLT,HEX.HOLE,5X10	1	
9-50	99461050254	BOLT,HEX HOLE,5X25S	1	
9-53	99961609000	BEARING,BALL,#609	1	
9-54	99961609002	BEARING,BALL,#609Z	1	
9-55	99350009002	RING,STOP,C9	1	
9-56	99351024002	RING,STOP,C-24,IN	1	
9-60	2103729080	HANDLE,LOCK	1	
9-71	99210080012	WASHER,S,8	1	
9-72	99201080011	WASHER,8	1	
9-73	1203729480	WHEEL,TPE,6"	1	
9-74	0493729420	COLLAR	1	
9-75	4413729022	GUARD,BLADE	1	
9-76	3143729420	BOLT,SPECIAL	1	
9-77	4813729420	STAY,WHEEL	1	
9-78	99210060062	WASHER,S,6	2	
9-79	99053060153	BOLT,HEX,6X15	2	
9-80	4423729021	BRACKET,COVER	1	
9-81	4453729420	HOLDER,BLADE GUARD	1	
9-82	99210060062	WASHER,S,6	2	
9-83	99053060353	HEX, HOLE BOLT 6X35	2	
9-88	4963729020	HOLDER,MUD FLAP	1	
9-89	5003729020	FLAP,MUD	1	
9-90	99461050124	BOLT,HEX,5X12S	3	

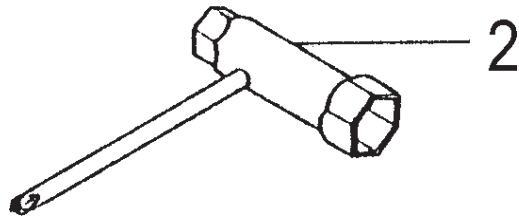
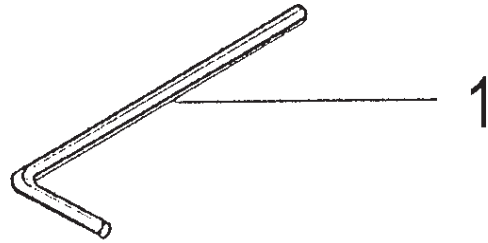

ITEM	PART NUMBER	DESCRIPTION	QTY	COMMENTS
10-1	81320000200	WRENCH,HEX,4	1	
10-2	8292000080	SPANNER,COMBI,13X19	1	



ITEM	PART NUMBER	DESCRIPTION	QTY	COMMENTS
11-1	9060750020	DECAL,PUREFIRE	1	
11-2	9290750320	DECAL,TPE-260PF	1	
11-3	91505015200	DECAL,SYMBOL	1	
11-4	92337400200	DECAL,LEVEL	1	
11-6	91933111201	DECAL,CAUTION	1	
11-7	9293810020	DECAL,SYMBOL,PF	1	
11-16	9193728620	DECAL,CAUTION	1	
11-17	9203246620	DECAL,CAUTION	1	

Date: September 2000

Model & Serial: TPE-250
 All Units

Reason: The newer style of guard assembly is now available as an assembly. This assembly can be used to update the older style edgers, thus improving ease of height adjustment.
 All components depicted below are included. Individual part numbers can be found in the parts catalog for the TPE-2510, TPE-270PF or TPE-270PN.
 Gear cases are common between all models, so it is not necessary to replace the gear case when updating an older model to the newer style guard.

Part Number Changes:

Old Part #	New Part #	Description	Remarks
	441-37294-00	Safety Guard Assembly	

