

Tanaka Illustrated Parts Manual

Model Number:

TPE-2510

24cc Portable Edger

P/N 29249

Rev 001

Date 5-7-07



Nikko Tanaka Engineering U.S.A.,Ltd. • 1028 4th Street SW, Bldg B • Auburn, WA 98001 • Phone: (253) 333-1200 • Fax: (253) 333-1212

FIG. 1 ENGINE

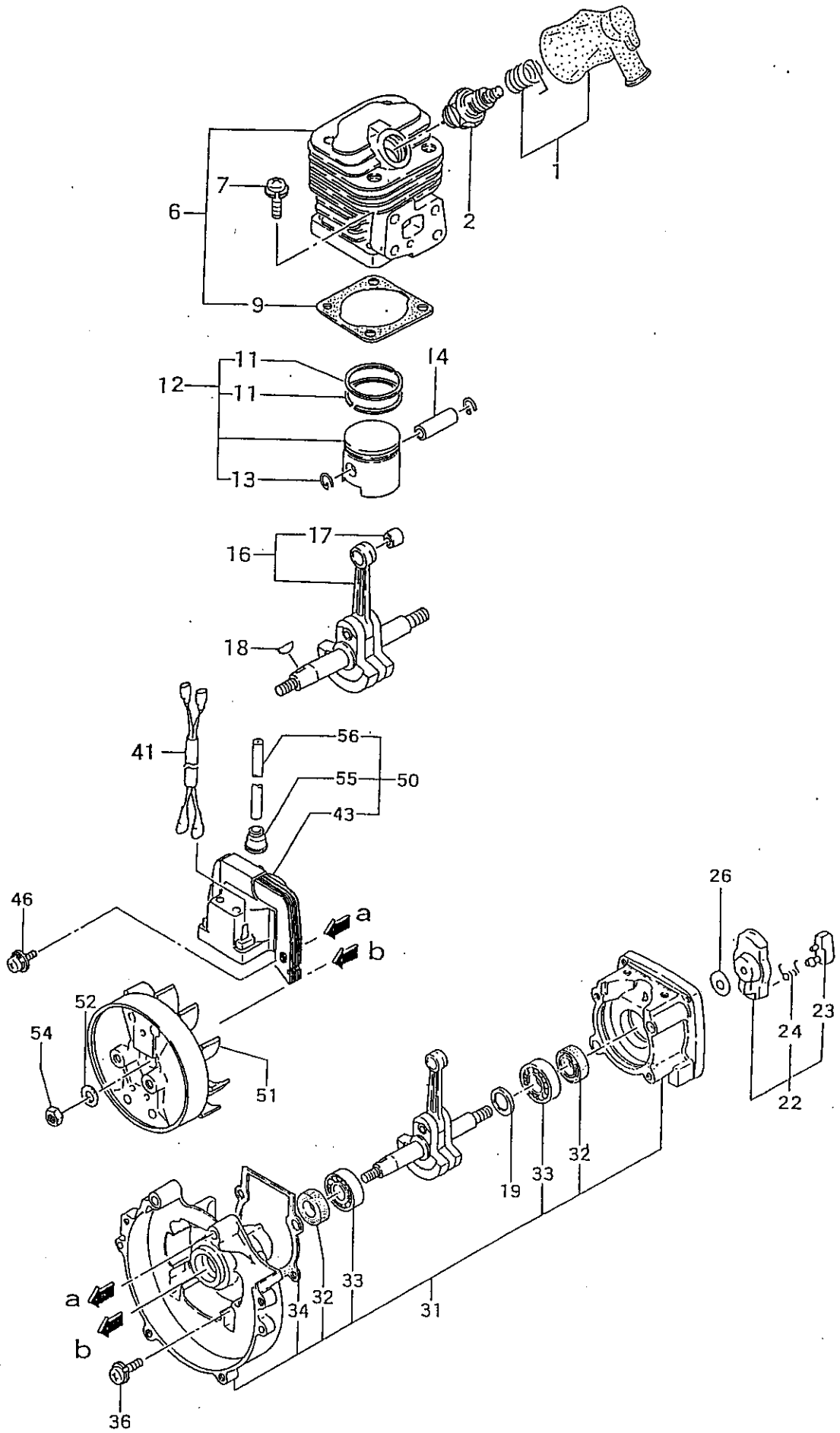

FIGURE 1

TPE 2510 PARTS LISTING

REF.	PART NO.	PART DESCRIPTION	Q	C	S	SERIAL NO.	REMARKS
1	157-0097A-900	CAP, SPARK PLUG, ASS'Y	1		B		
2	018-11660-21	PLUG, SPARK	1		B		
6	001-00980-90	CYLINDER SET	1		C		
7	994-14050-181	SCREW, S, 5X18	4		D		
9	017-00980-200	GASKET, CYLINDER	1		C		
11	041-01601-200	RING, PISTON	2		A		
12	030-01601-90	PISTON SET	1		B		
13	039-01620-200	CIRCLIP, PISTON PIN	2		A		
14	037-01601-200	PIN, PISTON	1		C		
16	046-0631A-81	CRANKSHAFT	1		D		
17	999-62081-225	BEARING, NEEDLE, F-810	1		C		
18	068-10100-200	KEY, WOODRUFF, 3X13X4.5	1		C		
19	330-00200-210	SHIM, 12.2X19X.10	1		V		Shims are "as needed" to obtain correct c/s side clearance.
19	330-00200-220	SHIM, 12.2X19X.15	1		V		
19	330-00200-230	SHIM, 12.2X19X.20	1		V		
19	330-00200-240	SHIM, 12.2X19X.30	1		V		
22	798-06500-900	PULLEY, STARTER, ASS'Y	1		C		
23	788-06500-20	PAWL, STARTER	1		C		
24	790-06097-200	SPRING, STARTER PAWL	1		C		
26	359-10112-203	WASHER, CLUTCH B	1		A		
31	072-00980-900	CRANKCASE, ASS'Y	1		D		Includes bearings, seals and gasket.
32	999-66122-206	SEAL, OIL, #TC12227	2		C		
33	999-61600-100	BEARING, BALL, #6001	2		B		
34	090-06097-200	GASKET, CRANKCASE	1		C		
36	994-14050-251	SCREW, 5X25	4		D		
41	178-06550-80	CORD, STOP, 180mm	1		D		
43	167-20521-80	COIL, IGNITION	1		D		
46	994-16050-201	SCREW, 5X20/WS	2		D		
50	167-20521-90	COIL, IGNITION	1		D		
51	155-20508-80	MAGNETO ROTOR COMP	1		D		
52	992-01070-011	WASHER, 7	1		D		
54	066-00000-200	NUT, FLYWHEEL	1		D		
55	560-20517-200	CAP, RUBBER	1		C		
56	264-20516-200	LEAD, HIGH TENSION	1		C		

* Indicates the part is included in a kit or assembly and is not available individually. Q=Quan. used
 C=Interchangeability S=Stocking code: A=Fast moving B=Med. fast C=Med. move D=Slow move
 E=N.L.A. F=Superceded or replaced by a new part

FIG. 2 FUEL SYSTEM

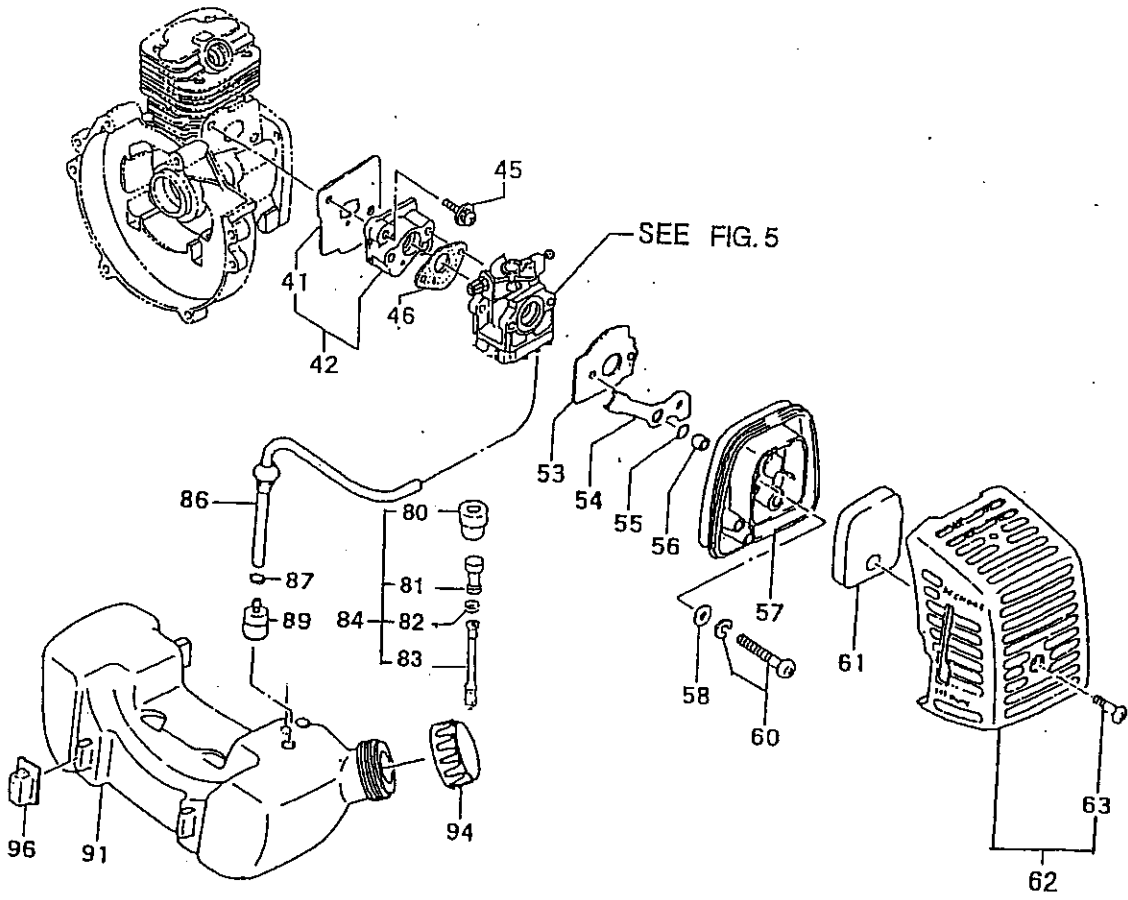

FIGURE 2

TPE 2510 PARTS LISTING

REF.	PART NO.	PART DESCRIPTION	Q	C	S	SERIAL NO.	REMARKS
41	403-0631A-20	GASKET,INLET MANIFOLD	1		C		
42	404-0099F-90	INSULATOR,CARBURETOR	1		C		
45	994-16050-221	SCREW,5X22/WS	2		D		
46	402-0602K-21	GASKET,CARBURETOR	1		A		
53	436-0162V-20	BASE,CLEANER	1		C		
54	528-00980-200	PLATE,CHOKE	1		C		
55	999-67008-012	O-RING,S-8	1		C		
56	470-0602N-200	COLLAR,CLEANER	1		C		
57	423-0637C-800	BODY,CLEANER	1		A		
58	992-00050-011	WASHER,SMALL,5	2		B		
60	994-14050-571	SCREW,5X57,S	2		D		
61	446-0637C-200	ELEMENT,CLEANER	1		A		
62	051-0099F-90	SET,CLEANER COVER	1		C		
63	380-0637C-200	BOLT,CLEANER COVER	1		C		
80	561-00070-20	COVER,AIR VENT	1		C		
81	646-3252L-90	AIR VENT VALVE ASSY	1		C		
82	680-00206-200	CLIP,5.5	1		C		
83	405-36152-21	PIPE,AIR VENT	1		C		
84	564-0652A-91	ASSY,AIR VENT	1		C	~T245220	
84	564-00070-90	ASSY,AIR VENT	1		C	T245221~	
86	223-0162V-900	PIPE,FUEL,ASS'Y	1		A		
87	680-00731-201	CLIP 6.3	1		B		
89	675-04042-80	FILTER,FUEL	1		A		
91	591-00996-20	TANK,FUEL	1		C		
94	595-0656B-90	CAP,GAS BLACK,NON VENT	1		A		
96	655-00940-201	CUSHION,FUEL TANK	2		A		

* Indicates the part is included in a kit or assembly and is not available individually. Q=Quan. used
 C=Interchangeability S=Stocking code: A-Fast moving B=Med. fast C=Med. move D=Slow move
 E=N.L.A. F=Superceded or replaced by a new part

FIG. 3 ENGINE COMPONENTS

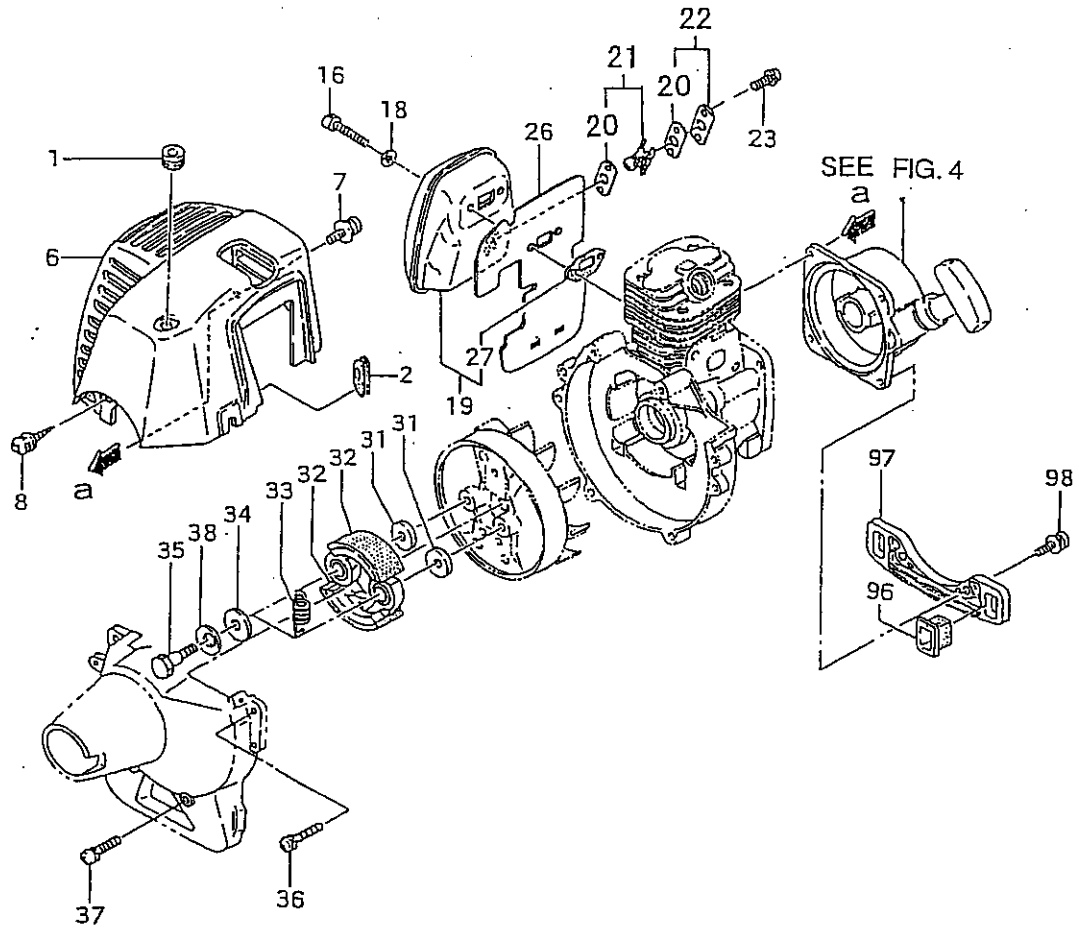

FIGURE 3

TPE 2510 PARTS LISTING

REF.	PART NO.	PART DESCRIPTION	Q	C	S	SERIAL NO.	REMARKS
1	202-01003-201	GROMMET,SECONDARY CORD	1		C		
2	203-0631A-200	GROMMET	1		D		
6	738-0631A-201	PROTECTOR,MUFFLER	1		C		
7	994-15040-222	SCREW,PS,4X22	2		A		
8	990-72045-164	SCREW,TAPPING,4.5X16	2		C		
16	990-51050-503	BOLT,HEX,5X50	2		C		
18	992-01050-011	WASHER,5	2		A		
19	704-0099F-90	SET,MUFFLER	1		C		
20	751-04200-201	GASKET,MUFFLER	2		C		
21	732-0099F-90	SET,SPARK ARRESTER	1		D		
22	734-0099K-90	PIPE,EXHAUST (CA)	1		C		
23	994-34040-081	SCREW,4X8/S	2		D		
26	133-0631A-201	SHIELD,HEAT	1		B		
27	737-06100-21	GASKET,MUFFLER	1		B		
31	359-02103-200	WASHER,CLUTCH,B	2		B		
32	290-01620-800	SHOE,CLUTCH	2		A		
33	342-0630B-200	SPRING,CLUTCH	1		A		
34	348-0602R-200	WASHER,CLUTCH A	2		B		
35	357-0075T-200	BOLT,STEP	2		A		
36	994-16050-202	SCREW,5X20/WS	2		D		
37	994-16050-422	SCREW,5X42/WS	2		D		
38	992-05080-030	WASHER,8	2		C		
96	655-00940-201	CUSHION,FUEL TANK	2		A		
97	653-0631A-200	BRACKET,TANK	1		C		
98	994-15040-222	SCREW,PS,4X22	2		A		

* Indicates the part is included in a kit or assembly and is not available individually. Q=Quan. used
 C=Interchangeability S=Stocking code: A-Fast moving B=Med. fast C=Med. move D=Slow move
 E=N.L.A. F=Superceded or replaced by a new part

FIG. 4 RECOIL STARTER

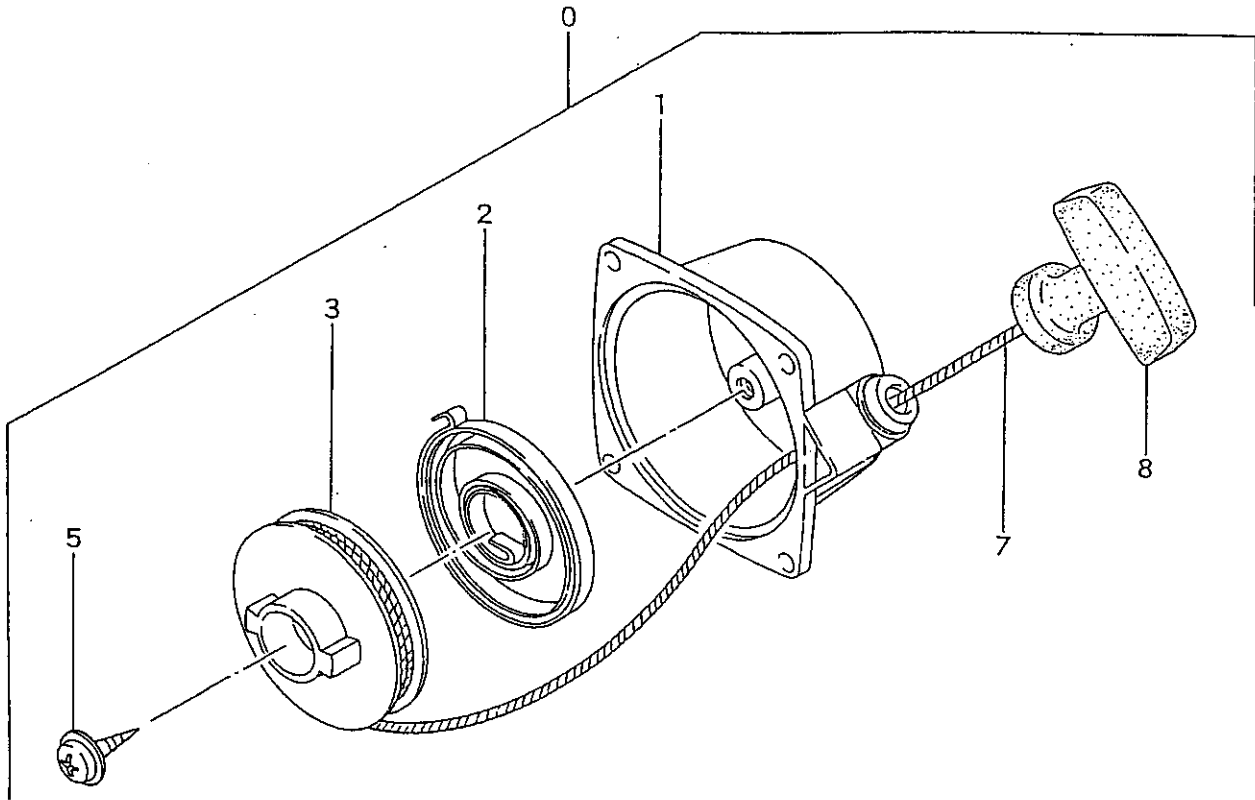

FIGURE 4

TPE 2510 PARTS LISTING

REF.	PART NO.	PART DESCRIPTION	Q	C	S	SERIAL NO	REMARKS
0	762-06097-902	STARTER,RECOIL ASS'Y	1		B		
1	772-06097-80	BODY,RECOIL STARTER	1		C		
2	780-06097-200	SPRING,RECOIL	1		A		
3	774-06097-200	PULLEY,STARTER	1		A		
5	839-02010-20	SCREW,SET	1		C		
7	783-06097-200	ROPE,STARTER	1		C		
8	785-06097-200	HANDLE,STARTER	1		C		

FIG. 5 CARBURETOR

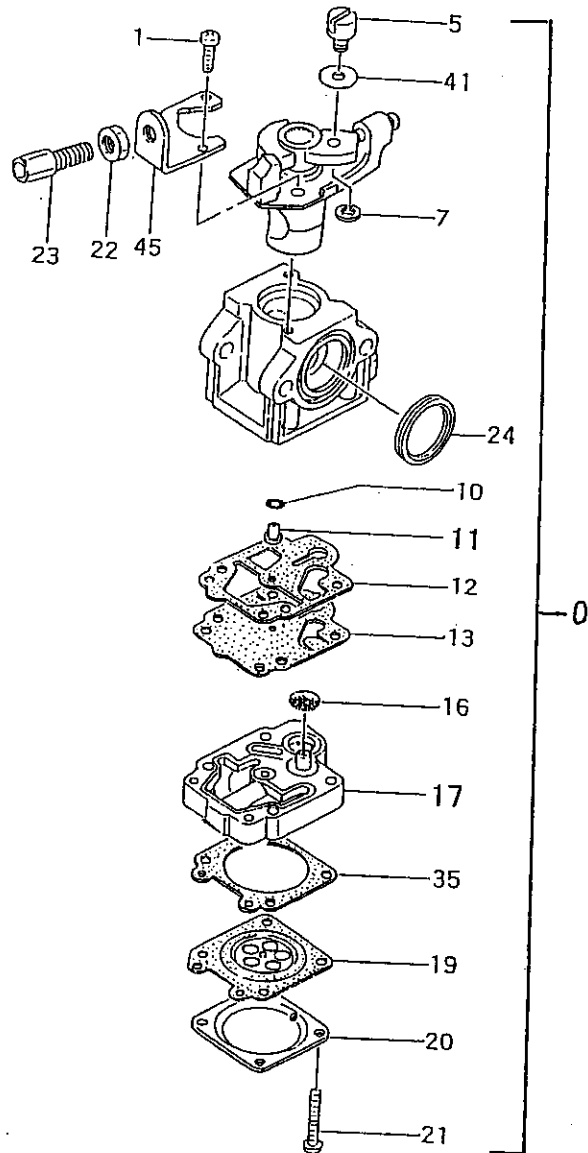

FIGURE 5

TPE 2510 PARTS LISTING

REF.	PART NO.	PART DESCRIPTION	Q	C	S	SERIAL NO.	REMARKS
0	455-00996-90	CARBURETOR SET	1		B		
1	514-25100-200	SCREW, THROTTLE SET	2		D		
5	539-25120-200	SWIVEL	1		D		
7	489-25100-200	RING, STOP	1		D		
10	550-25100-200	O-RING	1		C		
11	599-2000W-430	JET, MAIN, #43	1		D		
12	~	*GASKET, PUMP	1		B		* Contained in Carb. Repair Kit 650-25124-900 (Not available individually)
13	~	*DIAPHRAGM, PUMP	1		B		
16	~	*SCREEN, INLET	1		C		
17	575-25152-80	BODY, PUMP	1		C		
19	~	*DIAPHRAGM, METERING	1		A		
20	476-25004-200	COVER, DIAPHRAGM	1		D		
21	548-25101-200	SCREW, SET	4		D		
22	614-25137-200	ADJUSTER, CABLE	1		D		
23	991-01060-013	NUT, 6	1		B		
24	431-0634C-200	PACKING, CLEANER	1		C		
35	~	*GASKET, DIAPHRAGM	1		A		
41	549-25165-20	WASHER, THRUST	1		D		
45	544-25164-200	STAY, ADJUST, CABLE	1		C		

* Indicates the part is included in a kit or assembly and is not available individually. Q=Quan. used
 C=Interchangeability S=Stocking code: A=Fast moving B=Med. fast C=Med. move D=Slow move
 E=N.L.A. F=Superseded or replaced by a new part

FIG. 6 CLUTCH CASE

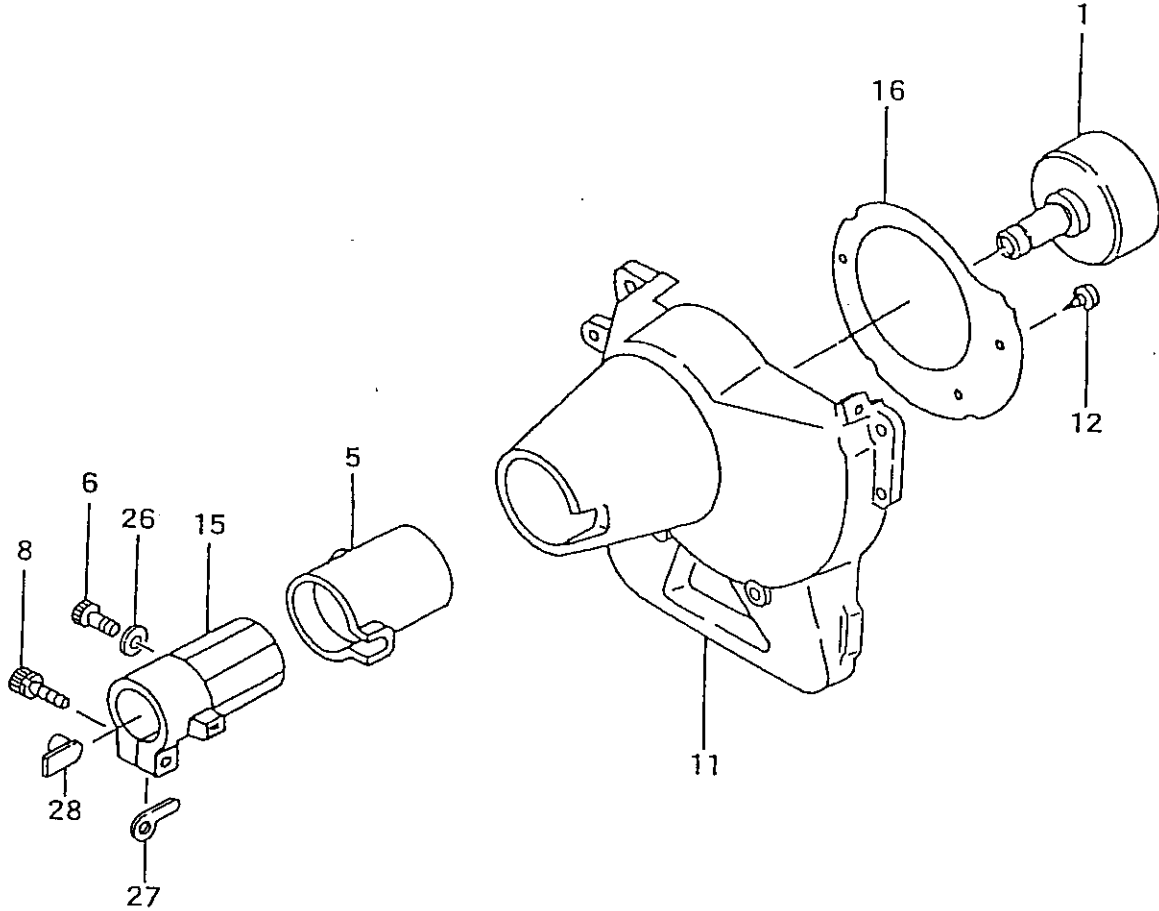

FIGURE 6

TPE 2510 PARTS LISTING

REF.	PART NO.	PART DESCRIPTION	Q	C	S	SERIAL NO.	REMARKS
1	289-0099E-80	CLUTCH DRUM	1		C		
5	599-00980-21	CUSHION,RUBBER	1		C		
6	990-51050-163	BOLT,HEX,5X16	1		C		
8	994-61050-254	BOLT,HEX HOLE,5X25S	1		C		
11	112-00980-81	CASE,FAN	1		C		
12	990-72045-164	SCREW,TAPPING,4.5X16	3		C		
15	360-00996-20	PIPE HOLDER,TPE	1		A		
16	091-00980-20	SHIELD,HEAT	1		C		
26	992-01050-061	WASHER,5	1		D		
27	324-37350-20	WASHER,GEAR CASE	1		D		
28	361-00990-20	METAL FITTING	1		P		

FIG. 7 GEAR CASE

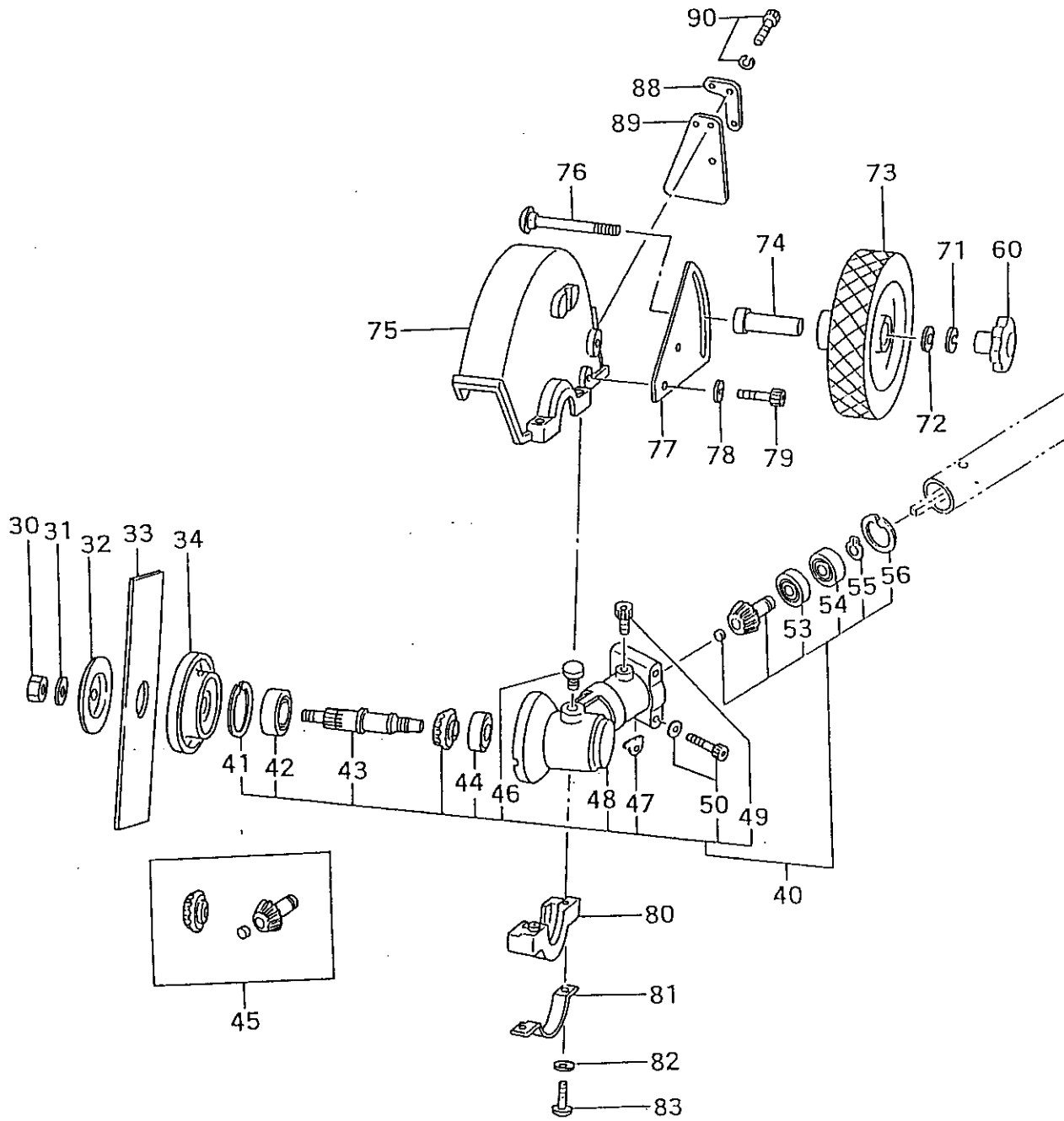

FIGURE 7

TPE 2510 PARTS LISTING

REF.	PART NO.	PART DESCRIPTION	Q	C	S	SERIAL NO.	REMARKS
30	991-06080-001	NUT,8/L.H.	1		C		
31	992-01080-011	WASHER,8	1		A		
32	311-37290-20	CAP,CUTTER HOLDER	1		D		
33	435-37290-20	BLADE,TPE-250	1		B		
34	310-37290-80	HOLDER,CUTTER	1		C		
40	300-37290-90	CASE,GEAR,ASSY	1		D		
41	993-51032-002	RING,STOP,C-32 IN	1		C		
42	999-61620-103	BEARING,BALL #6201D	1		D		
43	304-37290-20	SHAFT,GEAR	1		D		
44	999-61628-000	BEARING,BALL,#628	1		D		
45	301-37290-00	SET,GEAR/PINION	1		D		
46	994-23080-100	BOLT,8X10	1		C		
47	324-33410-201	WASHER,GEAR CASE	1		C		
48	300-37290-21	CASE,GEAR	1		C		
49	990-51050-103	BOLT,HEX.HOLE,5X10	1		C		
50	994-61050-254	BOLT,HEX HOLE,5X25S	1		C		
53	999-61609-000	BEARING,BALL,#609	1		D		
54	999-61609-002	BEARING,BALL,#609Z	1		D		
55	993-50009-002	RING,STOP,C9	1		D		
56	993-51024-002	RING,STOP,C-28,IN	1		C		
60	210-37290-80	HANDLE,LOCK	1		C		
71	992-10080-012	WASHER,S,8	1		B		
72	992-01080-011	WASHER,8	1		A		
73	120-37294-80	WHEEL,TPE,6"	1		B		
74	049-37294-20	COLLAR	1		A		
75	441-37290-22	BLADE GUARD	1		C		
76	314-37294-20	SPECIAL BOLT	1		A		
77	481-37294-20	WHEEL STAY	1		B		
78	990-53060-153	BOLT,HEX,6X15	2		B		
79	992-10060-062	WASHER,S,6	2		A		
80	442-37290-21	COVER BRACKET	1		A		
81	445-37294-20	BLADE GUARD HOLDER	1		A		
82	992-10060-062	WASHER,S,6	2		A		
83	990-53060-353	HEX, HOLE BOLT 6X35	2		A		
88	496-37290-20	HOLDER,MUD FLAP	1		C		
89	500-37290-20	FLAP,MUD	1		C		
90	994-61050-124	BOLT,HEX,5X12S	3		C		

* Indicates the part is included in a kit or assembly and is not available individually. Q=Quan. used
 C=Interchangeability S=Stocking code: A-Fast moving B=Med. fast C=Med. move D=Slow move
 E=N.L.A. F=Superseded or replaced by a new part

FIG. 8 THROTTLE LEVER / HANDLE

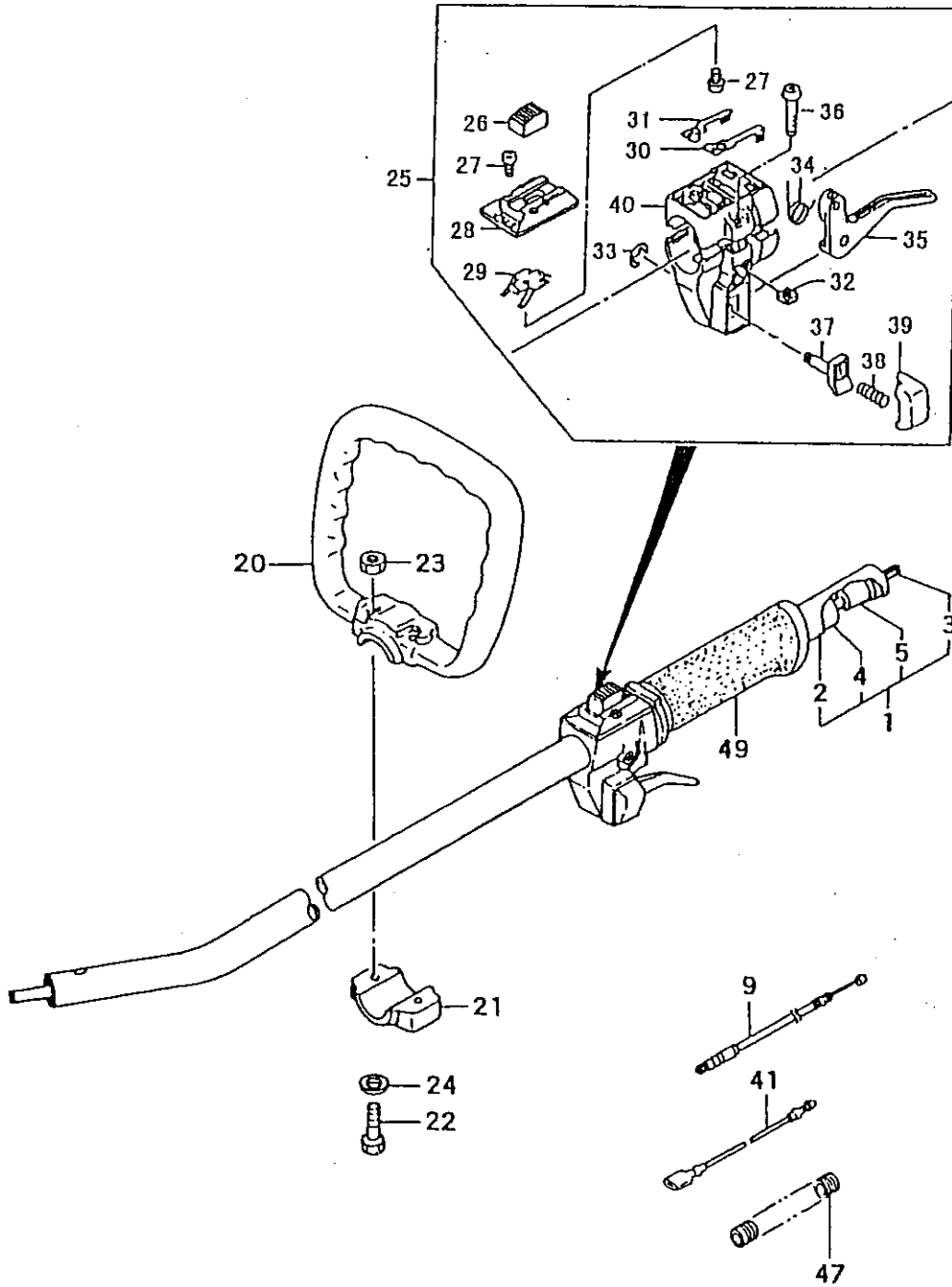

FIGURE 8

TPE 2510 PARTS LISTING

REF.	PART NO.	PART DESCRIPTION	Q	C	S	SERIAL NO.	REMARKS
1	353-37290-90	SET,DRIVE SHAFT PIPE	1		D		
2	341-37290-20	PIPE,DRIVE SHAFT	1		D		
3	344-37290-20	SHAFT,FLEXIBLE	1		D		
4	350-37290-20	LINER,FLEXIBLE	1		D		
5	320-37290-20	SPACER	1		C		
9	885-37394-80	WIRE,THROTTLE	1		C		
20	500-33316-20	HANDLE	1		D		
21	506-33316-200	BRACKET,HANDLE A	1		D		
22	990-23060-401	BOLT,P,6X40	2		D		
23	991-01060-011	NUT,6	2		A		
24	992-01060-011	WASHER,6	2		A		
25	870-37286-90	LEVER,THROTTLE ASS'Y	1		D		
26	162-37101-200	SWITCH,STOP	1		C		
27	993-42030-081	SCREW, TAPPING, 3X8	3		D		
28	259-37101-200	BASE,STOP SWITCH	1		C		
29	262-37101-200	SPRING,STOP SWITCH	1		D		
30	177-37101-200	TERMINAL,EARTH B	1		C		
31	176-37101-200	TERMINAL,EARTH A	1		D		
32	315-33340-20	NUT,SPECIAL 5MM	2		C		
33	993-55060-001	RING,STOP,6	1		D		
34	832-37101-200	SPRING,RETURN	1		C		
35	880-37101-200	LEVER,THROTTLE	1		B		
36	994-31050-201	SCREW,5X20	1		D		
37	853-37101-200	SHAFT,LOCK BUTTON	1		D		
38	958-37101-200	SPRING,LOCK,BUTTON	1		D		
39	956-37101-200	BUTTON,LOCK	1		D		
40	260-33317-20	BODY,STOP BUTTON,B	1		C		
41	178-37394-80	CORD,STOP 430mm	2		C		
47	164-10019-00	TUBE,PROTECTION	1		C		
49	504-37300-200	GRIP,SHAFT	1		D		

* Indicates the part is included in a kit or assembly and is not available individually. Q=Quan. used
 C=Interchangeability S=Stocking code: A-Fast moving B=Med. fast C=Med. move D=Slow move
 E=N.L.A. F=Superseded or replaced by a new part

FIG. 9 TOOLS

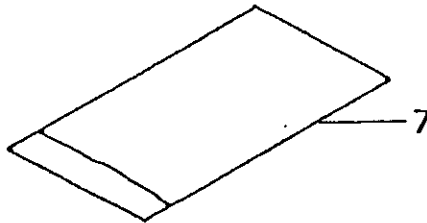
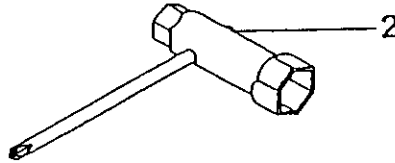
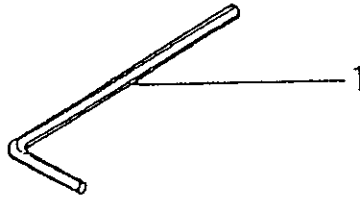

FIGURE 9

TPE 2510 PARTS LISTING

REF.	PART NO.	PART DESCRIPTION	Q	C	S	SERIAL NO.	REMARKS
1	813-20000-200	WRENCH,HEX,4	1		D		
2	829-20000-80	SPANNER,COMBI,13X19	1		C		
7	948-39907-200	BAG,TOOL	1		D		

FIG. 10 LABELS

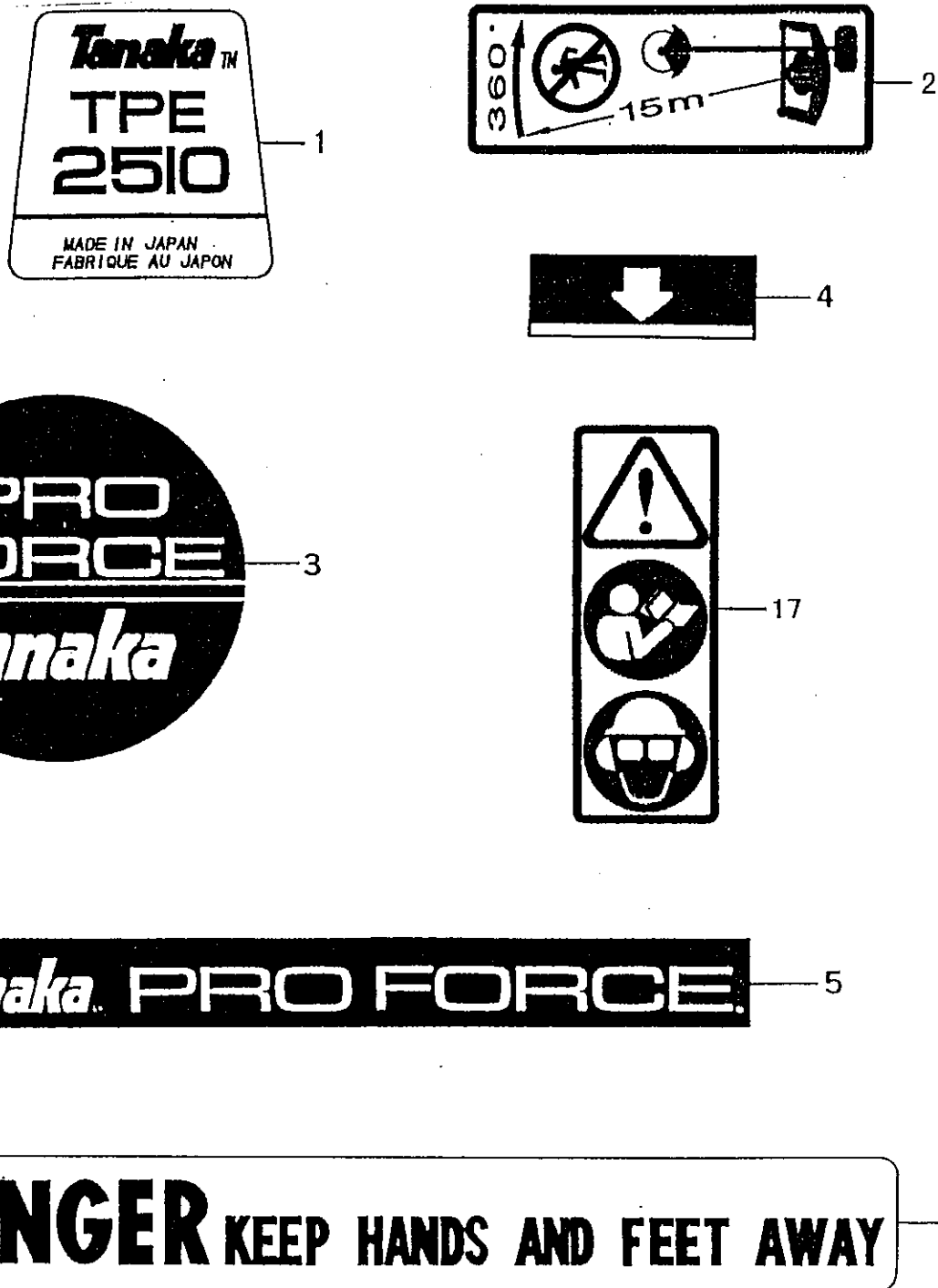

FIGURE 10

TPE 2510 PARTS LISTING

REF.	PART NO.	PART DESCRIPTION	Q	C	S	SERIAL NO.	REMARKS
1	906-37294-20	NAME PLATE TPE-2510	1		C		
2	919-37286-20	DECAL, CAUTION	1		D		
3	950-37503-200	DECAL, PRO-FORCE A	1		D		
4	923-37400-200	DECAL, LEVEL	1		D		
5	951-31310-200	DECAL, PRO-FORCE B	1		D		
6	919-33111-201	DECAL, CAUTION	1		D		
17	920-32466-20	DECAL	1		D		