

# ***Tanaka***

## **Parts Catalog**

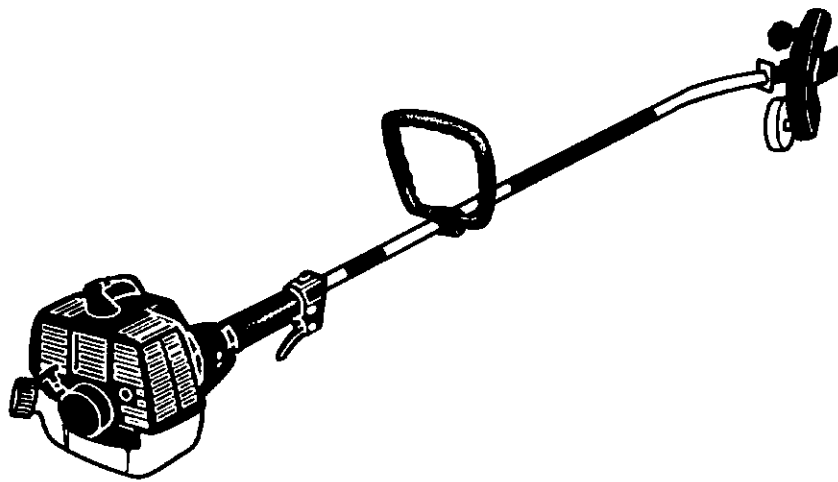

## **Portable Edger**

**Model : TPE-250**

# TPE-250

## OPTIONS AND ACCESSORIES

### SHOULDER STRAP

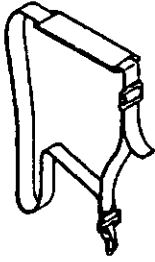

PSS-175

### MANUALS / CATALOGS

970-47290-201 Owner's Manual  
DPL-LE250-HST Parts Catalog

### PERFECT MIX® 2-Cycle Engine Oil

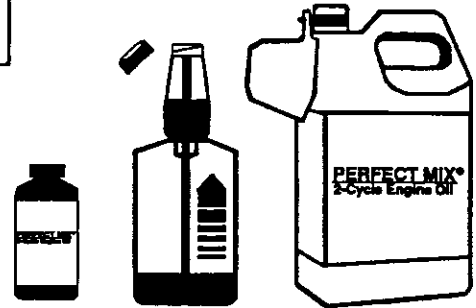

700109 2.8 oz. Bottle, 1 Gallon Size (24")  
700108 16 oz. Self-measuring Bottle (24")  
700110 1 Gallon Jug Commercial Size (6")  
\* Case Quantity

### SPECIAL TOOLS

006-29326-000	Flywheel Remover	001-29000-000	Tachometer
009-29323-500	Piston Pin Remover	070-2000W-500	Pressure Tester
015-23998-000	Gear Shaft Remover	070-2000W-501	Carb. Tool Kit
016-29338-000	Pinion Remover		

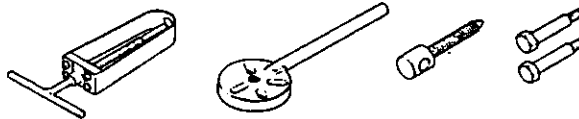

FIG.1 ENGINE

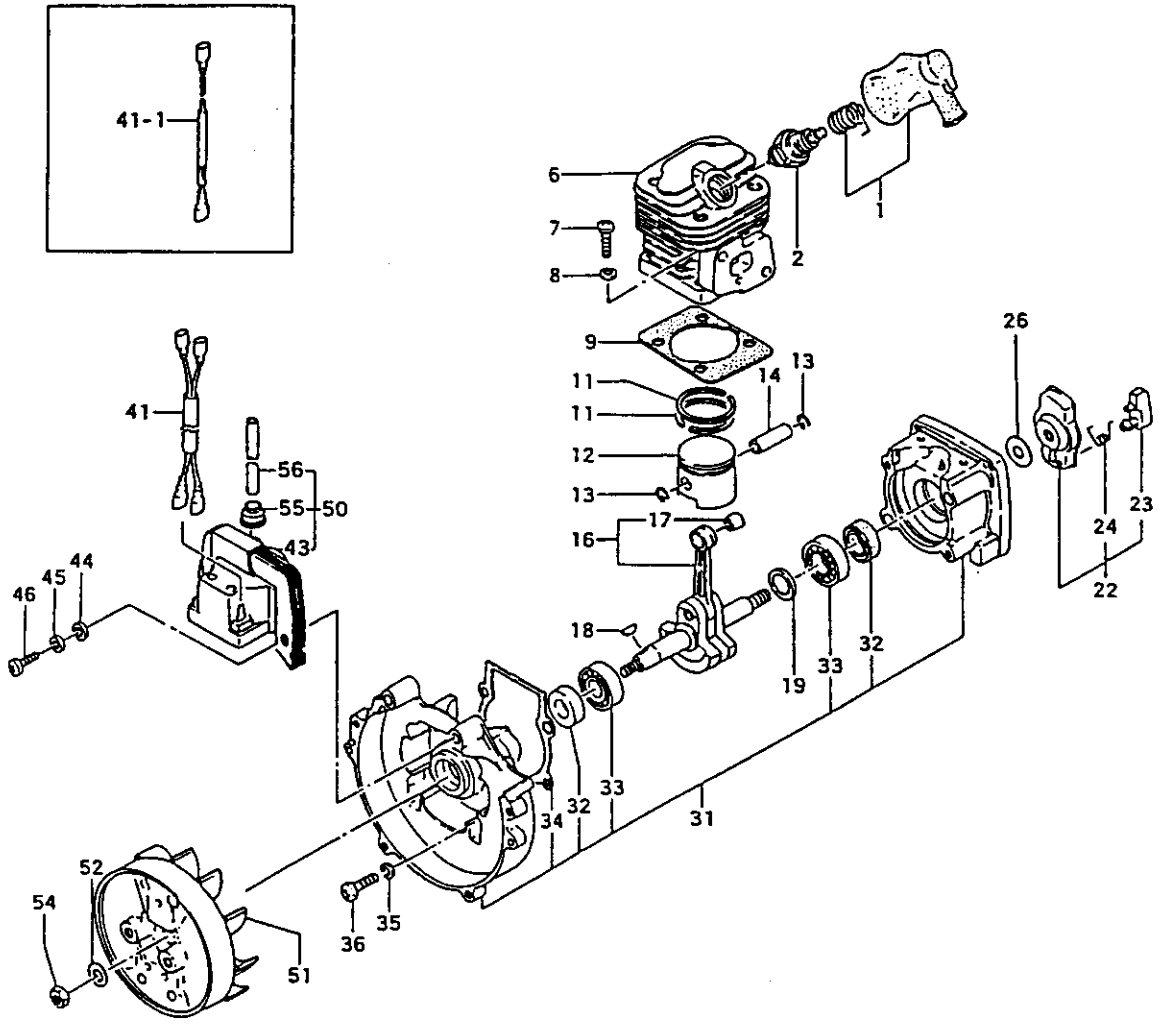

FIGURE 1

TPE-250 PARTS LISTING

REF.	PART NO.	PART DESCRIPTION	Q	C	S	SERIAL NO.	REMARKS
1	157-0097A-900	CAP,SPARK PLUG,ASS'Y	1		B		
2	018-11660-21	PLUG,SPARK	1		B		
6	002-00980-21	CYLINDER	1		C		
7	990-11050-181	SCREW,5X18	4		B		
8	992-10050-012	WASHER,S,5	2		A		
9	017-00980-200	GASKET,CYLINDER	1		C		
11	041-01601-200	RING,PISTON	2		A		
12	031-01601-20	PISTON	1		C		
13	039-01620-200	CIRCLIP,PISTON PIN	2		A		
14	037-01601-200	PIN,PISTON	1		C		
16	046-0631A-81	CRANKSHAFT	1		D		
17	999-62081-225	BEARING,NEEDLE,F-810	1		C		
18	068-10100-200	KEY,WOODRUFF,3X13X4.5	1		C		
19	330-00200-210	SHIM,12.2X19X.10	1		D		Shims are "as needed" to obtain correct c/s side clearance.
19	330-00200-220	SHIM,12.2X19X.15	1		D		
19	330-00200-230	SHIM,12.2X19X.20	1		D		
19	330-00200-240	SHIM,12.2X19X.30	1		D		
22	798-06500-900	PULLEY,STARTER,ASS'Y	1		C		
23	788-06500-20	PAWL,STARTER	1		C		
24	790-06097-200	SPRING,STARTER PAWL	1		C		
26	359-10112-203	WASHER,CLUTCH B	1		A		
31	072-00980-900	CRANKCASE,ASS'Y	1		D		Includes bearings, seals & gasket
32	999-66122-240	SEAL,OIL,12227	2		A		
33	999-61600-100	BEARING,BALL,#6001	2		B		
34	090-06097-200	GASKET,CRANKCASE	1		C		
35	992-10050-012	WASHER,S,5	4		A		
36	990-11050-251	SCREW,5X25	4		D		
41-1	178-01280-80	CORD,STOP,380mm	2		D	-N159150	
41	178-06550-80	CORD,STOP,180mm	1		D	N159151~	
43	167-20521-80	COIL,IGNITION	1		D		
44	992-00050-011	WASHER,SMALL,5	2		C		
45	992-10050-012	WASHER,S,5	2		A		
46	990-11050-201	SCREW,MX20	2		D		
50	167-20521-90	COIL,IGNITION	1		D		
51	155-20508-800	ROTOR,MAGNETO	1		D		
52	992-01070-011	WASHER,7	1		D		
54	066-00000-200	NUT,FLYWHEEL	1		D		
55	560-20517-200	CAP,RUBBER	1		C		
56	264-20516-200	LEAD,HIGH TENSION	1		C		

\* Indicates the part is included in a kit or assembly and is not available individually. Q=Quan. used C=Interchangeability S=Stocking code: A=Fast moving B=Med. fast C=Med. move D=Slow move E=N.L.A. F=Superseded or replaced by a new part

# FIG.2 ENGINE COMPONENTS

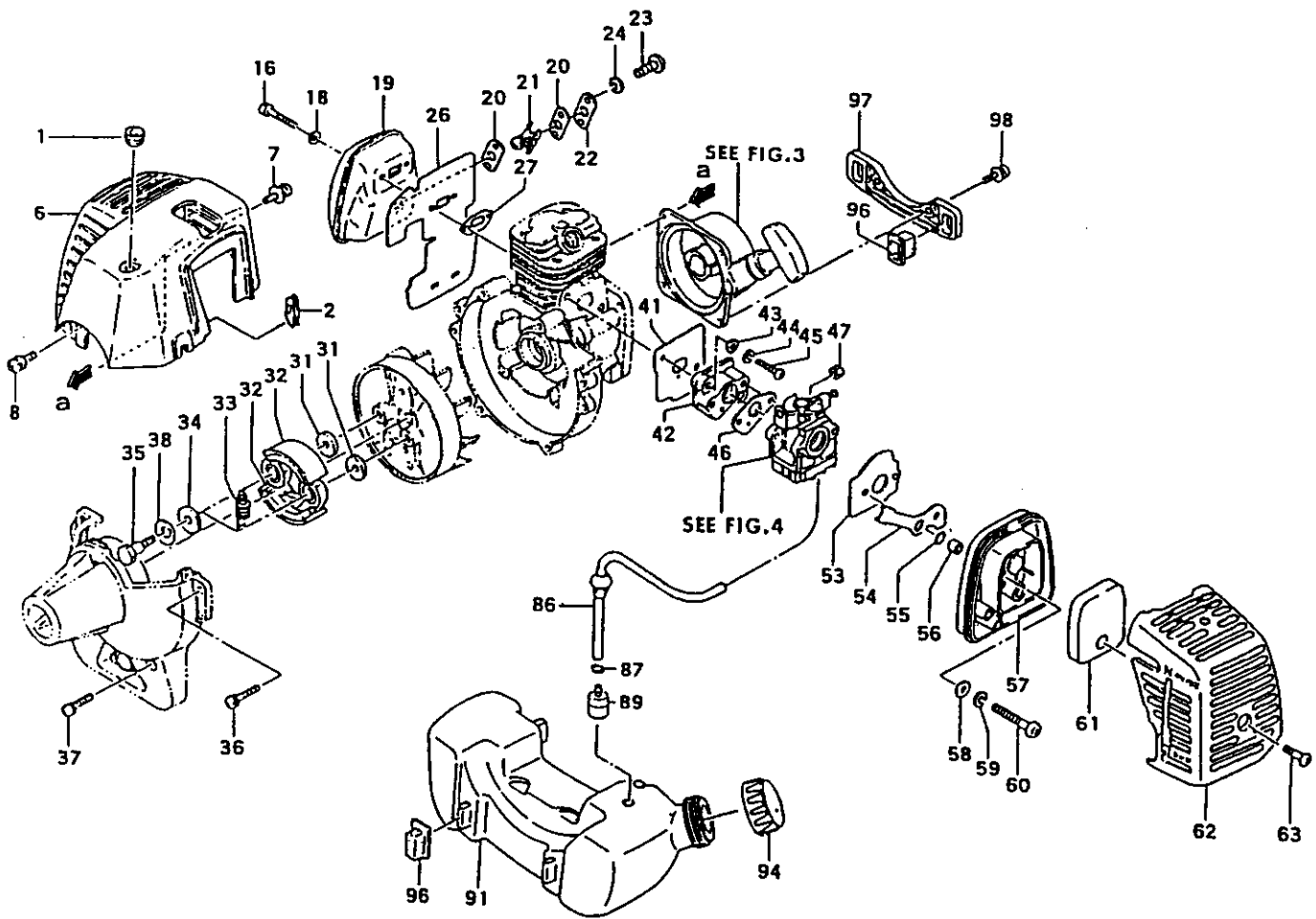

FIGURE 2

## TPE-250 PARTS LISTING

REF.	PART NO.	PART DESCRIPTION	Q	C	S	SERIAL NO.	REMARKS
1	202-01003-201	GROMMET,SECONDARY CORD	1		C		
2	203-0631A-200	GROMMET	1		D		
6	738-0631A-201	PROTECTOR,MUFFLER	1		C		
7	994-15040-222	SCREW,PS,4X22	2		A		
8	994-15040-122	SCREW,4X12/PS	2		C		
16	990-51050-503	BOLT,HEX,5X50	2		C		
18	992-01050-011	WASHER,5	2		A		
19	706-0631A-801	MUFFLER	1		D		
20	751-04200-201	GASKET,MUFFLER	2		C		
21	732-0631A-200	ARRESTER,SPARK	1		C		
22	734-0631A-20	PIPE,TAIL	1		D		
23	990-11040-081	SCREW,4X8	2		C		
24	992-10040-012	WASHER,S,4	2		B		
26	133-0631A-201	SHIELD,HEAT	1		B		
27	737-06100-21	GASKET,MUFFLER	1		B		
31	359-02103-200	WASHER,CLUTCH,B	2		B		
32	290-01620-800	SHOE,CLUTCH	2		A		
33	342-0630B-200	SPRING,CLUTCH	1		A		
34	348-0602R-200	WASHER,CLUTCH A	2		B		
35	357-0075T-200	BOLT,STEP	2		A		
36	994-14050-202	SCREW,5X20/S	2		C		
37	994-14050-352	SCREW,5X35/S	2		C		
38	992-05080-030	WASHER,8	2		C		
41	403-0631A-202	GASKET,INLET MANIFOLD	1		A		
42	404-0631A-800	INSULATOR,CARBURETOR	1		B		
43	992-00050-011	WASHER,SMALL,5	2		C		
44	992-10050-012	WASHER,S,5	2		A		
45	990-11050-221	SCREW,5X22	2		B		
46	402-0602K-21	GASKET,CARBURETOR	1		B		
47	991-01060-013	NUT,6	1		B	-N159150	
53	436-0162V-20	BASE,CLEANER	1		C		
54	528-00980-200	PLATE,CHOKE	1		D		
55	999-67008-012	O-RING,S-8	1		C		
56	470-0602N-200	COLLAR,CLEANER	1		C		
57	423-0637C-800	BODY,CLEANER	1		B		
58	992-00050-011	WASHER,SMALL,5	2		C		
59	992-10050-012	WASHER,S,5	2		A		
60	990-11050-571	SCREW,5X57	2		C		
61	446-0637C-200	ELEMENT,CLEANER	1		A		

\* Indicates the part is included in a kit or assembly and is not available individually. Q=Quan. used C=Interchangeability S=Stocking code: A=Fast moving B=Med. fast C=Med. move D=Slow move E=N.L.A. F=Superseded or replaced by a new part

FIGURE 2 cont.

TPE-250 PARTS LISTING

REF.	PART NO.	PART DESCRIPTION	Q	C	S	SERIAL NO.	REMARKS
62	452-0637C-200	COVER,CLEANER	1		C	-N219620	
62	452-0637C-21	COVER,CLEANER	1		C	N219621-	
63	380-0637C-200	BOLT,CLEANER	1		B		
86	223-0162V-900	PIPE,FUEL,ASS'Y	1		A		
87	680-00731-201	CLIP	1		B		
89	675-04042-80	FILTER,FUEL	1		A		
91	591-0635A-200	TANK	1		C		
94	595-0650A-90	CAP,TANK	1		A		
96	655-00940-201	CUSHION,FUEL TANK	4		A		
97	653-0631A-200	BRACKET,TANK	1		C		
98	994-15040-222	SCREW,PS,4X22	2		A		

\* Indicates the part is included in a kit or assembly and is not available individually. Q=Quan. used C=Interchangeability S=Stocking code: A-Fast moving B=Med. fast C=Med. move D=Slow move E=N.L.A. F=Superseded or replaced by a new part

# FIG.3 RECOIL STARTER

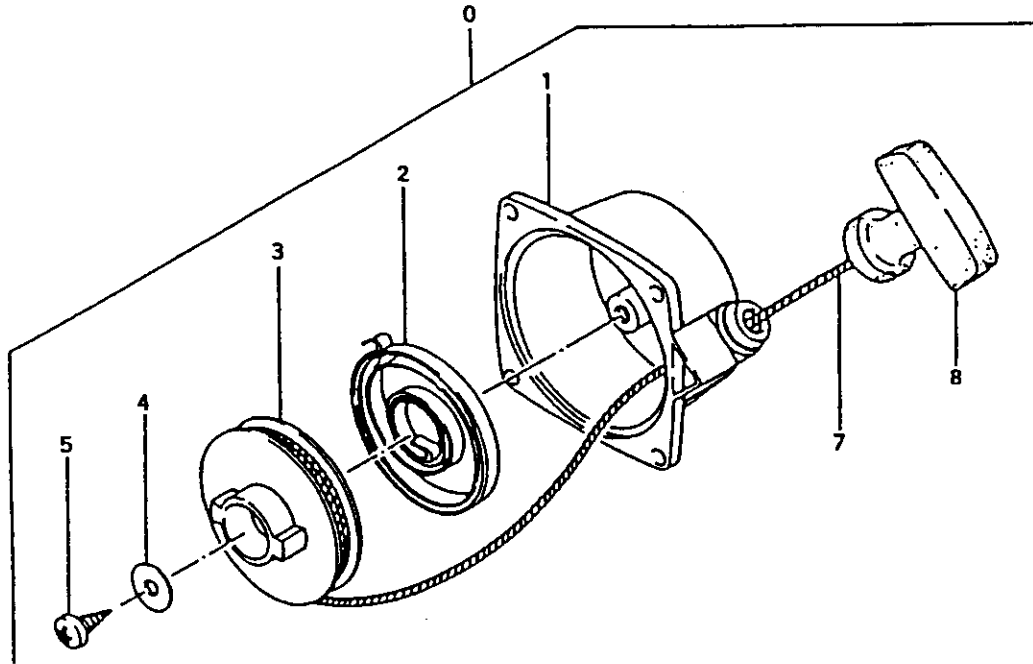

FIGURE 3

## TPE-250 PARTS LISTING

REF.	PART NO.	PART DESCRIPTION	Q	C	S	SERIAL NO.	REMARKS
0	762-06097-902	STARTER,RECOIL ASS'Y	1		B		
1	772-06097-80	BODY,RECOIL STARTER	1		C		
2	780-06097-200	SPRING,RECOIL	1		A		
3	774-06097-200	PULLEY,STARTER	1		B		
4	801-06091-200	WASHER,ROPE REEL	1		C		
5	839-00025-200	SCREW,SET	1		D		
7	783-06097-200	ROPE,STARTER	1		C		
8	785-06097-200	HANDLE,STARTER	1		C		



**FIG.4 CARBURETOR**

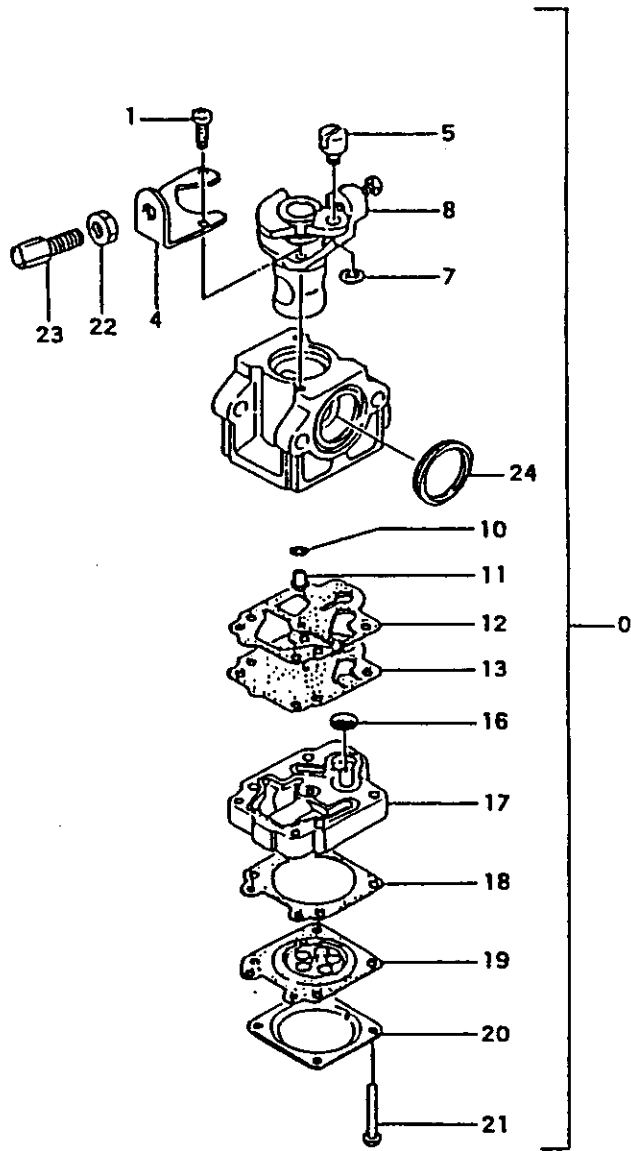

FIGURE 4

## TPE-250 PARTS LISTING

REF.	PART NO.	PART DESCRIPTION	Q	C	S	SERIAL NO.	REMARKS
0	455-25155-90	CARBURETOR,ASSY	1		D	-N219620	
0	455-25155-91	CARBURETOR,ASSY	1		C	N219621-	
1	514-25100-200	SCREW,THROTTLE SET	2		D		
4	544-25120-200	STAY,ADJUST,CABLE	1		D		
5	539-25120-200	SWIVEL	1		D		
7	489-25100-200	RING,STOP	1		D		
8	488-25154-80	VALVE,THROTTLE	1		D		
10	----	*O-RING	1		C		
11	599-2000W-420	JET,MAIN,#42	1		F	-N091653	
11	599-2000W-430	JET,MAIN,#43	1		D	N091654--	
12	----	*GASKET,PUMP	1		B		
13	----	*DIAPHRAGM,PUMP	1		B		
16	----	*SCREEN,INLET	1		C		
17	575-25152-80	BODY,PUMP	1		C		Includes inlet needle
18	----	*GASKET,DIAPHRAGM .78mm	1		D		
19	----	*DIAPHRAGM,METERING	1		A		
20	476-25004-200	COVER,DIAPHRAGM	1		D		
21	548-25101-200	SCREW,SET	4		D		
22	991-01060-013	NUT,6	1		B	N219621-	
23	614-25137-200	ADJUSTER,CABLE	1		D	N219621-	
24	431-0634C-200	PACKING,CLEANER	1		C		

\* Indicates the part is included in a kit or assembly and is not available individually. Q=Quan. used C=Interchangeability S=Stocking code: A-Fast moving B=Med. fast C=Med. move D=Slow move E=N.L.A. F=Superseded or replaced by a new part

**FIG.5 CLUTCH CASE & GEAR CASE**

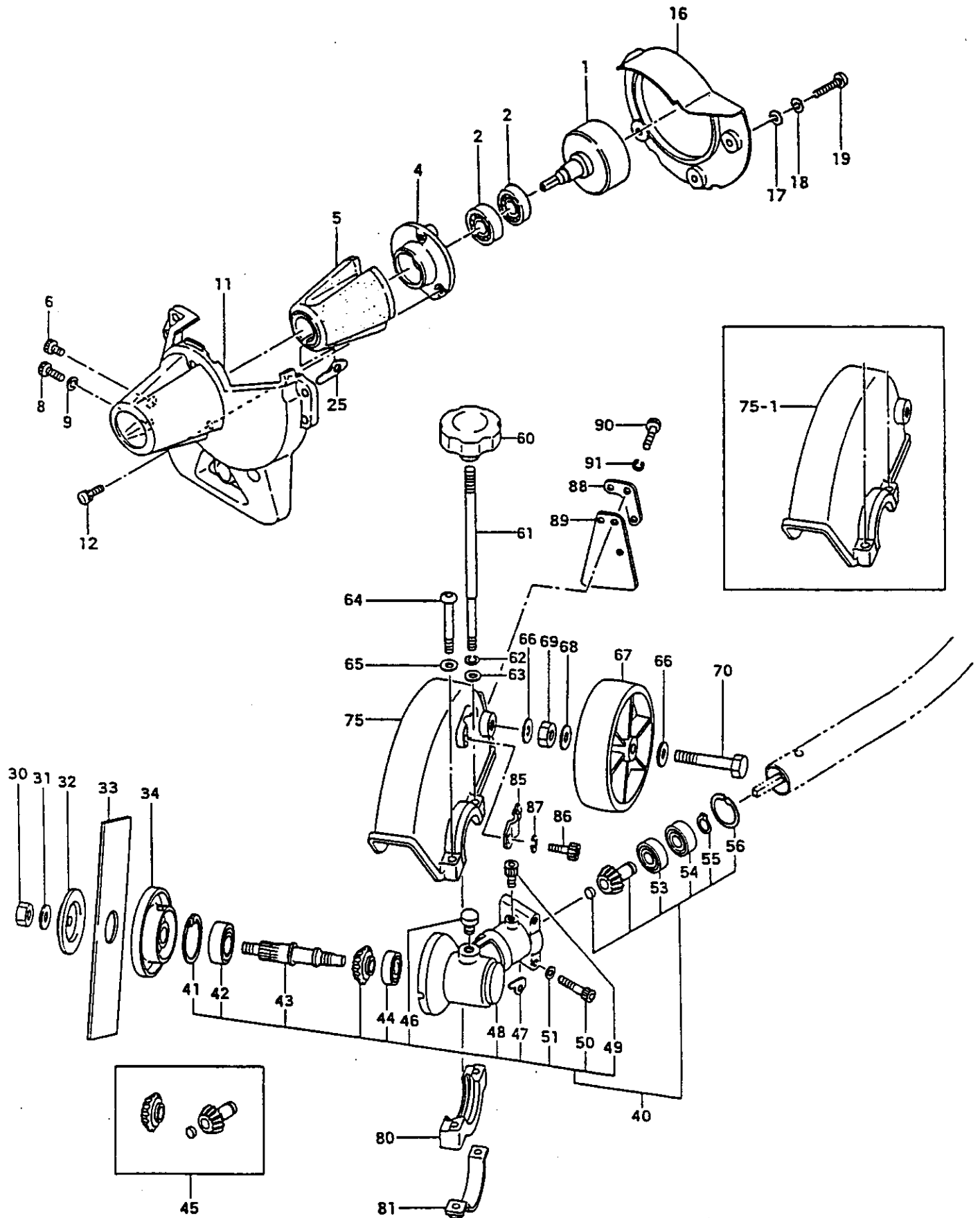

FIGURE 5

## TPE-250 PARTS LISTING

REF.	PART NO.	PART DESCRIPTION	Q	C	S	SERIAL NO.	REMARKS
1	289-0098T-80	DRUM,CLUTCH	1		D		
2	999-61600-102	BEARING,BALL,#6001Z	2		B		
4	374-0631A-20	FLANGE,CLUTCH	1		B		
5	599-0631A-802	CUSHION	1		C		
6	990-51050-103	BOLT,HEX.HOLE,5X10	1		C		
8	990-51050-203	BOLT,HEX.HOLE,5X20	1		C		
9	992-10050-062	WASHER,S,5	1		D		
11	112-0631A-201	CASE,FAN	1		D		
12	994-14050-122	SCREW,S,5X12	3		B		
16	091-0631A-200	SHIELD,HEAT	1		D		
17	992-01040-011	WASHER,4	3		C		
18	992-10040-012	WASHER,S,4	3		B		
19	990-11040-121	SCREW,4X12	3		B		
25	249-0165A-21	SPACER	1		D		
30	991-06080-001	NUT,8/L.H.	1		C		
31	992-01080-011	WASHER,8	1		A		
32	311-37290-20	CAP,CUTTER HOLDER	1		D		
33	435-37290-20	BLADE,CUTTING	1		B		
34	310-37290-80	HOLDER,CUTTER	1		C		
40	300-37290-90	CASE,GEAR,ASSY	1		D		
41	993-51032-002	RING,STOP,C-32 IN	1		C		
42	999-61620-103	BEARING,BALL #6201D	1		D		
43	304-37290-20	SHAFT,GEAR	1		D		
44	999-61628-000	BEARING,BALL,#628	1		D		
45	301-37290-00	SET,GEAR/PINION	1		D		
46	990-15080-100	SCREW,8X10	1		D		
47	324-37350-20	WASHER,GEAR CASE	1		D	-N091653	
47	324-33410-201	WASHER,GEAR CASE	1		C	N091654-	
48	300-37290-20	CASE,GEAR	1		D		
49	990-51050-103	BOLT,HEX.HOLE,5X10	1		C		
50	990-51050-253	BOLT,HEX,5X25	2		B		
51	992-10050-062	WASHER,S,5	2		D		
53	999-61609-000	BEARING,BALL,#609	1		D		
54	999-61609-002	BEARING,BALL,#609Z	1		D		
55	993-50009-002	RING,STOP,C9	1		D		
56	993-51024-002	RING,STOP,C-28,IN	1		C		
60	210-37290-80	HANDLE,LOCK	1		C		
61	478-37290-20	BOLT,ADJUST	1		C		
62	992-10060-012	WASHER,S,6	1		A		

\* Indicates the part is included in a kit or assembly and is not available individually. Q=Quan. used C=Interchangeability S=Stocking code: A-Fast moving B=Med. fast C=Med. move D=Slow move E=N.L.A. F=Superseded or replaced by a new part

FIGURE 5 cont.

TPE-250 PARTS LISTING

REF.	PART NO.	PART DESCRIPTION	Q	C	S	SERIAL NO.	REMARKS
63	992-01060-011	WASHER,6	1		A		
64	990-53060-453	BOLT,HEX,6X45	1		C		
65	992-01060-011	WASHER,6	1		A		
66	992-01080-011	WASHER,8	2		A		
67	120-37290-20	WHEEL	1		D		
68	992-01080-011	WASHER,8	1		A		
69	991-74080-003	U-NUT,8	1		C		
70	297-37290-20	SHAFT,WHEEL	1		D		
75	441-37290-21	GUARD,SAFETY	1		C		
80	442-37290-20	BRACKET,GUARD	1		C		
81	445-37290-80	HOLDER,GUARD	1		C		
85	209-37290-20	HOLDER	1		C	N219621~	
86	990-51050-123	BOLT,HEX,5X12	2		C	N219621~	
87	992-10050-062	WASHER,S,5	2		D	N219621~	
88	496-37290-20	HOLDER,MUD FLAP	1		C	N219621~	
89	500-37290-20	FLAP,MUD	1		C	N219621~	
90	990-51050-123	BOLT,HEX,5X12	3		C	N219621~	
91	992-10050-062	WASHER,S,5	3		D	N219621~	

\* Indicates the part is included in a kit or assembly and is not available individually. Q=Quan. used C=Interchangeability S=Stocking code: A-Fast moving B=Med. fast C=Med. move D=Slow move E=N.L.A. F=Superceded or replaced by a new part

# FIG. 5 CLUTCH CASE

## UNITS AFTER SER. # Q243101

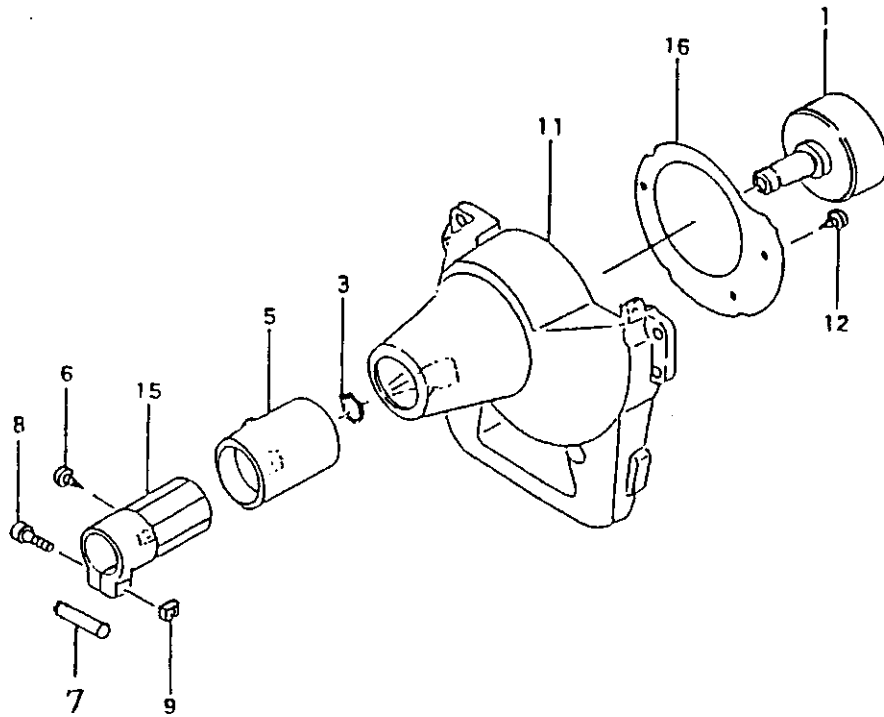

FIGURE 5a

### TPE-250 PARTS LISTING

REF.	PART NO.	PART DESCRIPTION	Q	C	S	SERIAL NO.	REMARKS
1	289-0099E-80	DRUM,CLUTCH	1		B		
3	993-50012-002	RING,STOP,C-12 EX	1		A		
5	599-00980-20	CUSHION,RUBBER	1		B	~R288067	
5	599-00980-21	CUSHION,RUBBER	1		C	R288068~	
6	990-73045-124	SCREW,TAPPING,4.5X12	1		D	~R288067	
6	990-74045-164	SCREW,TAPPING 4.5x16	1		C	R288068~	
7	096-04300-20	COLLAR 6.3x18	1		C	R288068~	
8	990-54050-203	BOLT,HEX,5X20	1		C	~R288067	
8	990-54050-253	BOLT,HEX 5x25	1		C	R288068~	
9	991-91050-001	NUT,5	1		C		
11	112-00980-80	CASE,FAN	1		B	~R288067	Includes bearings
11	112-00980-81	CASE,FAN	1		C	R288068~	Includes bearings
12	990-72045-164	SCREW,TAPPING,4.5X16	3		C		
15	360-00980-20	HOLDER,PIPE	1		C	~R288067	
15	360-00980-21	HOLDER,PIPE	1		C	R288068~	
16	091-00980-20	SHIELD,HEAT	1		C		

**FIG.6 HANDLE**

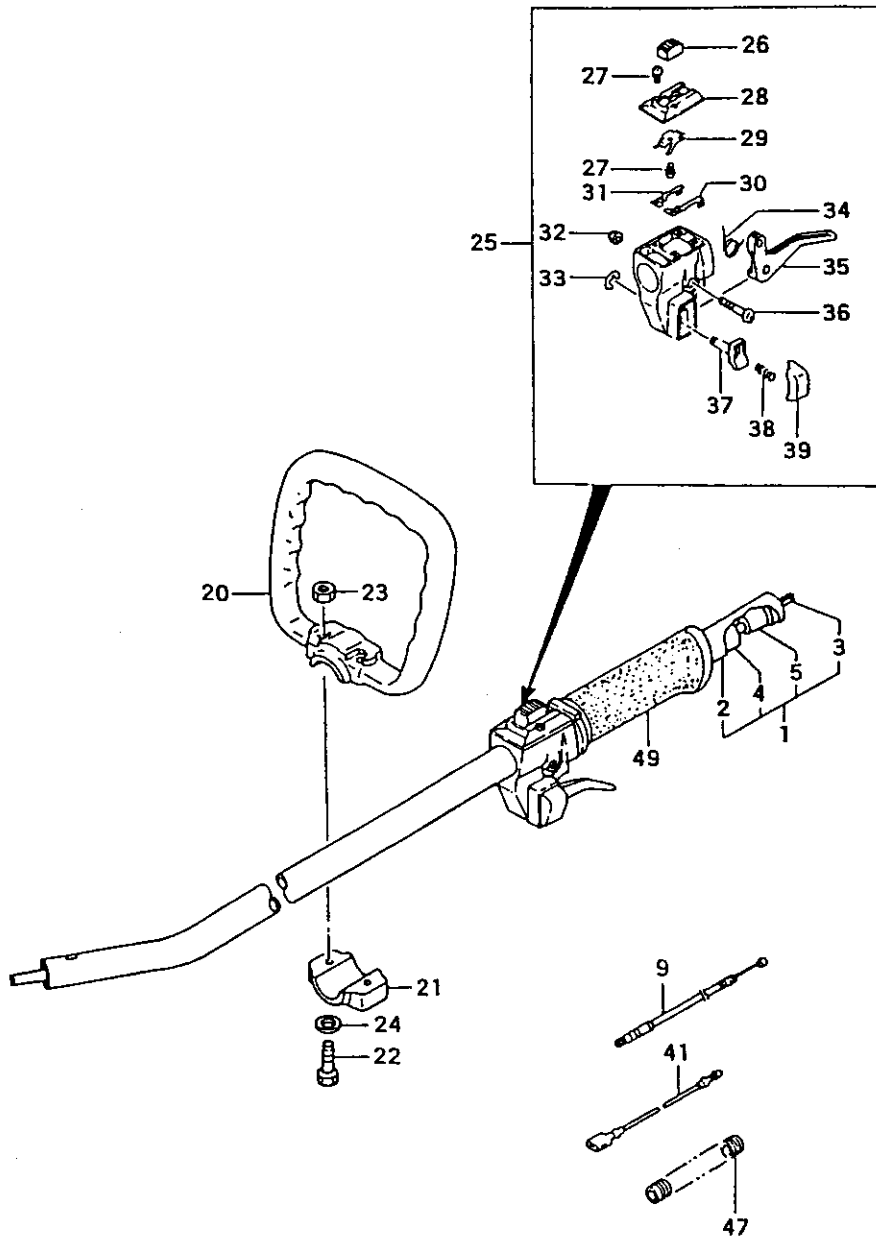

FIGURE 6

## TPE-250 PARTS LISTING

REF.	PART NO.	PART DESCRIPTION	Q	C	S	SERIAL NO.	REMARKS
1	353-37290-90	SET,DRIVE SHAFT PIPE	1		D		
2	341-37290-20	PIPE,DRIVE SHAFT	1		D		
3	344-37290-20	SHAFT,FLEXIBLE	1		D		
4	350-37290-20	LINER,FLEXIBLE	1		D		
5	320-37290-20	SPACER	1		C		
9	885-0631A-802	WIRE,THROTTLE	1		A	--N219620	
9	885-37394-80	WIRE,THROTTLE	1		C	N219621~	
20	500-33316-20	HANDLE	1		D		
21	506-33316-200	BRACKET,HANDLE A	1		D		
22	990-23060-401	BOLT,P,6X40	2		D		
23	991-01060-011	NUT,6	2		A		
24	992-01060-011	WASHER,6	2		A		
25	870-37300-900	LEVER, THROTTLE ASS'Y	1		A		
26	162-37101-200	SWITCH,STOP	1		C		
27	993-42030-081	SCREW, TAPPING, 3X8	3		D		
28	259-37101-200	BASE,STOP SWITCH	1		C		
29	262-37101-200	SPRING,STOP SWITCH	1		D		
30	177-37101-200	TERMINAL,EARTH B	1		C		
31	176-37101-200	TERMINAL,EARTH A	1		D		
32	991-86050-000	NUT,LOCK,5	1		D		
33	993-55060-001	RING,STOP,6	1		D		
34	832-37101-200	SPRING,RETURN	1		C		
35	880-37101-200	LEVER,THROTTLE	1		B		
36	994-31050-251	SCREW,S.,5X25	1		C		
37	853-37101-200	SHAFT,LOCK BUTTON	1		D		
38	958-37101-200	SPRING,LOCK,BUTTON	1		D		
39	956-37101-200	BUTTON,LOCK	1		D		
41	178-37300-801	CORD,STOP 230mm	2		C	--N219620	
41	178-37394-80	CORD,STOP 430mm	2		C	N219621~	
47	164-13014-010	TUBE,PROTECTION	1		D	--N219620	
47	164-10019-00	TUBE,PROTECTION	1		C	N219621~	
49	504-37300-200	GRIP,SHAFT	1		D		

\* Indicates the part is included in a kit or assembly and is not available individually. Q=Quan. used C=Interchangeability S=Stocking code: A=Fast moving B=Med. fast C=Med. move D=Slow move E=N.L.A. F=Superseded or replaced by a new part



# FIG.7 TOOLS

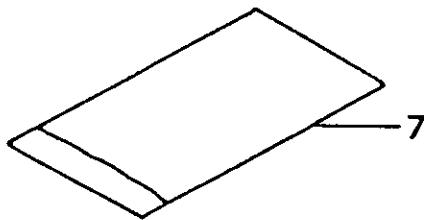
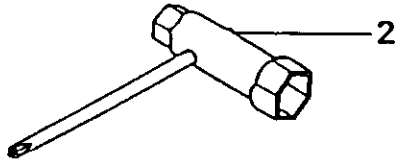
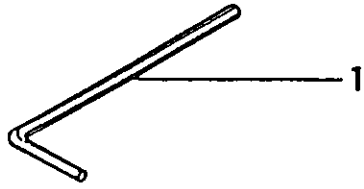

**FIGURE 7**

## TPE-250 PARTS LISTING

REF.	PART NO.	PART DESCRIPTION	Q	C	S	SERIAL NO.	REMARKS
1	813-20000-200	WRENCH,HEX,4	1		D		
2	829-20000-80	SPANNER,COMBI,13X19	1		C		
7	948-39907-200	BAG,TOOL	1		D		

FIG.8 MARKS

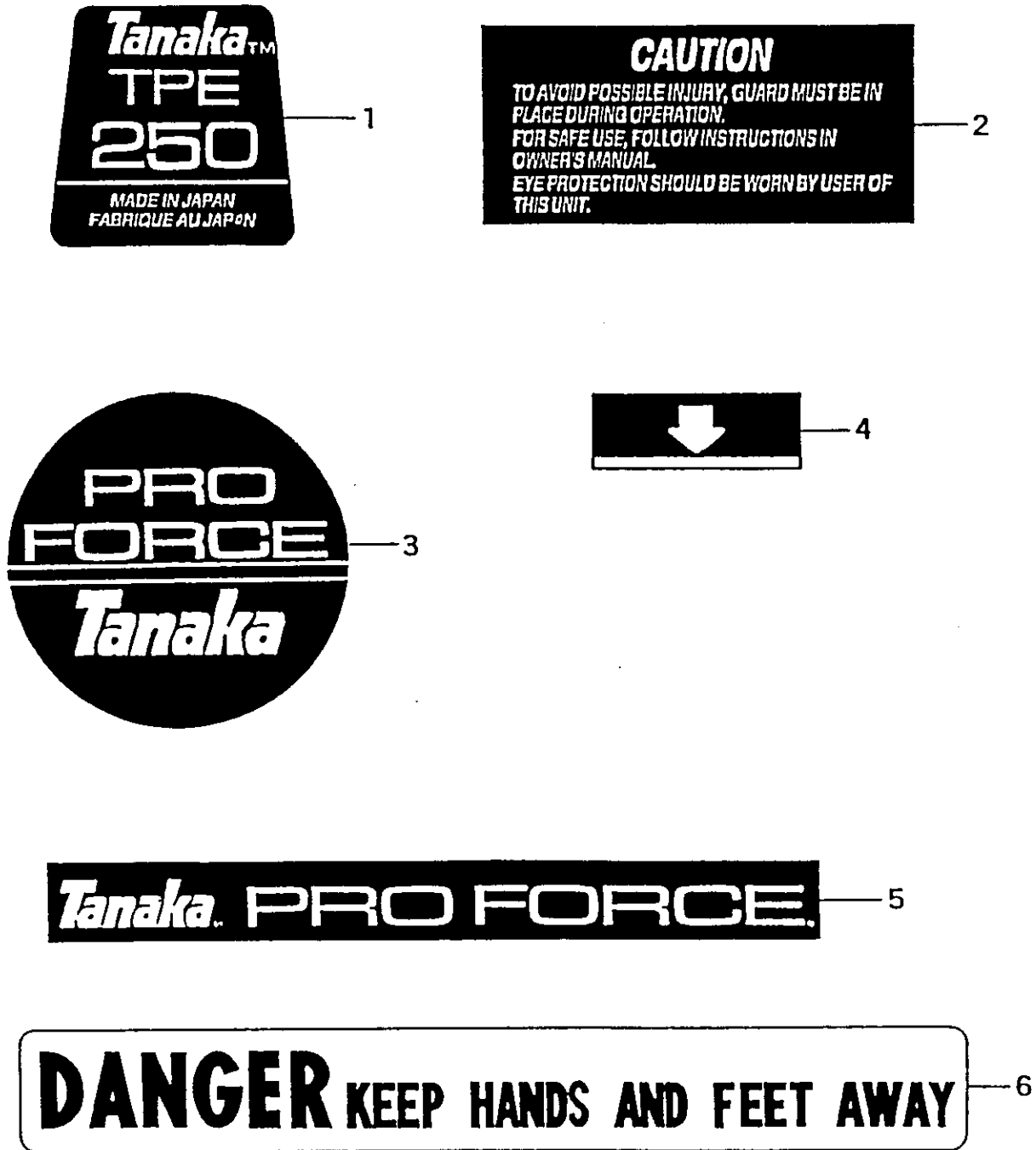

FIGURE 8

TPE-250 PARTS LISTING

REF.	PART NO.	PART DESCRIPTION	Q	C	S	SERIAL NO.	REMARKS
1	906-37290-20	DECAL	1		D		
2	919-37701-200	DECAL	1		D		
3	950-37503-200	DECAL,PRO-FORCE A	1		D		
4	923-37400-200	DECAL,LEVEL	1		D		
5	951-31310-200	DECAL,PRO-FORCE B	1		D		
6	919-33111-201	DECAL,CAUTION	1		D		

**Date:** September 2000

**Model & Serial:** TPE-250  
 All Units

**Reason:** The newer style of guard assembly is now available as an assembly. This assembly can be used to update the older style edgers, thus improving ease of height adjustment.  
 All components depicted below are included. Individual part numbers can be found in the parts catalog for the TPE-2510, TPE-270PF or TPE-270PN.  
 Gear cases are common between all models, so it is not necessary to replace the gear case when updating an older model to the newer style guard.

**Part Number Changes:**

Old Part #	New Part #	Description	Remarks
	441-37294-00	Safety Guard Assembly	

