

Tanaka Illustrated Parts Manual

Model Number:

TPB-400GX

40cc PowerBoard

P/N 31641

Rev 000

Date 4-24-06



Supplier To The Outdoor Power Equipment Industry

ISM, Inc. • 1028 4th Street SW • Auburn, WA 98001 • Phone: (253) 333-1200 • Fax: (253) 333-1212

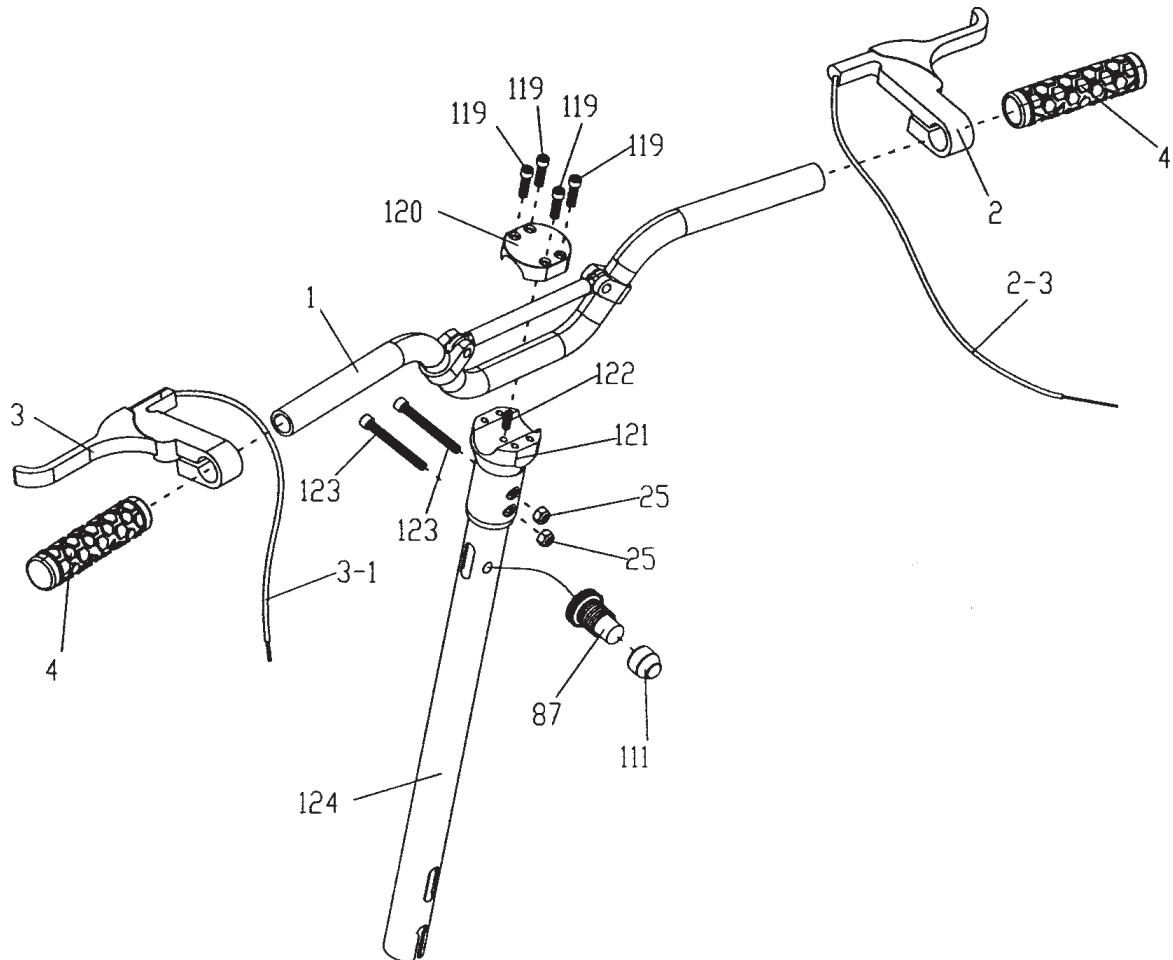

ITEM	PART NUMBER	DESCRIPTION	QTY	COMMENTS
1-1	31552	HANDLEBAR, RACING	1	
1-2	30799	THROTTLE LEVER ASSY	1	
1-2-3	31228	CABLE, THROTTLE	1	
1-3	30801	LEVER, BRAKE	1	Includes hardware - not sold separately
1-3-1	31229	CABLE, BRAKE	1	
1-4	30798	GRIP, HANDLE	2	
1-25	31658	NUT	2	
1-87	30806	SWITCH, BUTTON	1	
1-111	30938	COVER, STOP BUTTON	1	
1-119	31563	BOLT, M6xP1.0x20	4	
1-120	31564	STEERING STEM CAP	1	
1-121	31565	STEERING STEM	1	
1-122	31566	BOLT, M6xP1.0x15	1	
1-123	31567	BOLT, M6xP1.0x42	2	
1-124	31568	STEERING PIPE	1	

HEAD PIPE & FOLDING HANDLE • FIGURE 2

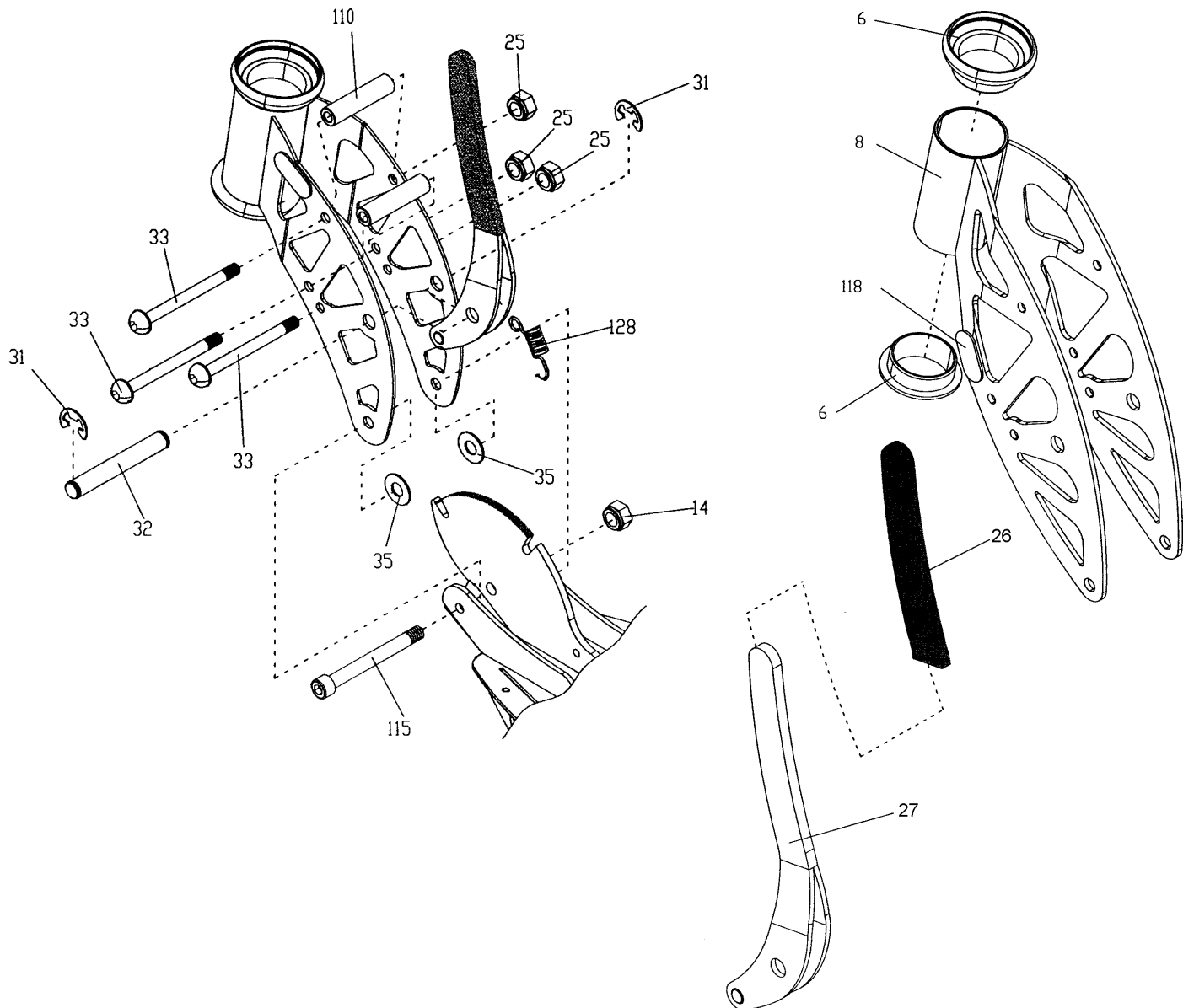

ITEM	PART NUMBER	DESCRIPTION	QTY	COMMENTS
2-6	30845	SPACER,FRONT HANDLE	1	
2-8	31681	TUBE,HEAD (BLUE)	1	
2-14	30821	NUT,M8xP1.25	1	
2-25	30936	NUT,M6xP1.0	3	
2-26	30870	GRIP,FOLDING HANDLE	1	
2-27	31682	HANDLE,FOLDING,(BLUE)	1	
2-31	30862	RING,E	2	
2-32	30863	PIN,HEAD TUBE	1	
2-33	30868	BOLT	3	
2-35	30864	WASHER	2	
2-110	31078	SPACER,T-937	2	
2-115	31663	BOLT	1	
2-118	31664	PAD,CUSHION	2	
2-128	31662	SPRING,FOLDING HANDLE	1	

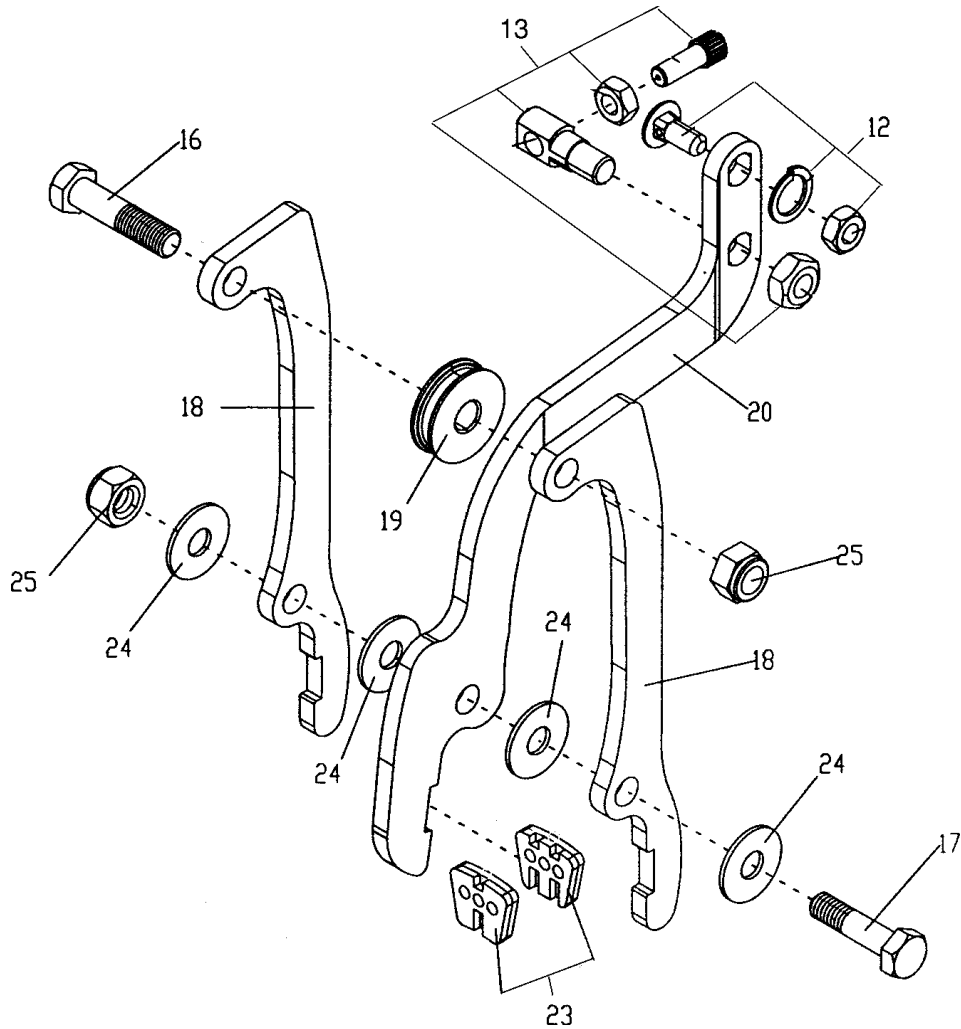

ITEM	PART NUMBER	DESCRIPTION	QTY	COMMENTS
3-12	30851	KIT,BRAKE ARM HDWE	1	
3-13	30852	KIT,BRAKE CABLE RECEIVER	1	
3-16	30855	BOLT	1	
3-17	30859	BOLT	1	
3-18	30854	ARM,BRAKE,(SMALL)	2	
3-19	30856	WHEEL,BRAKE	1	
3-20	30853	ARM,BRAKE,(LARGE)	1	
3-23	30930	BRAKE PAD SET	1	
3-24	30860	WASHER	4	
3-25	30936	NUT,M6xP1.0	2	

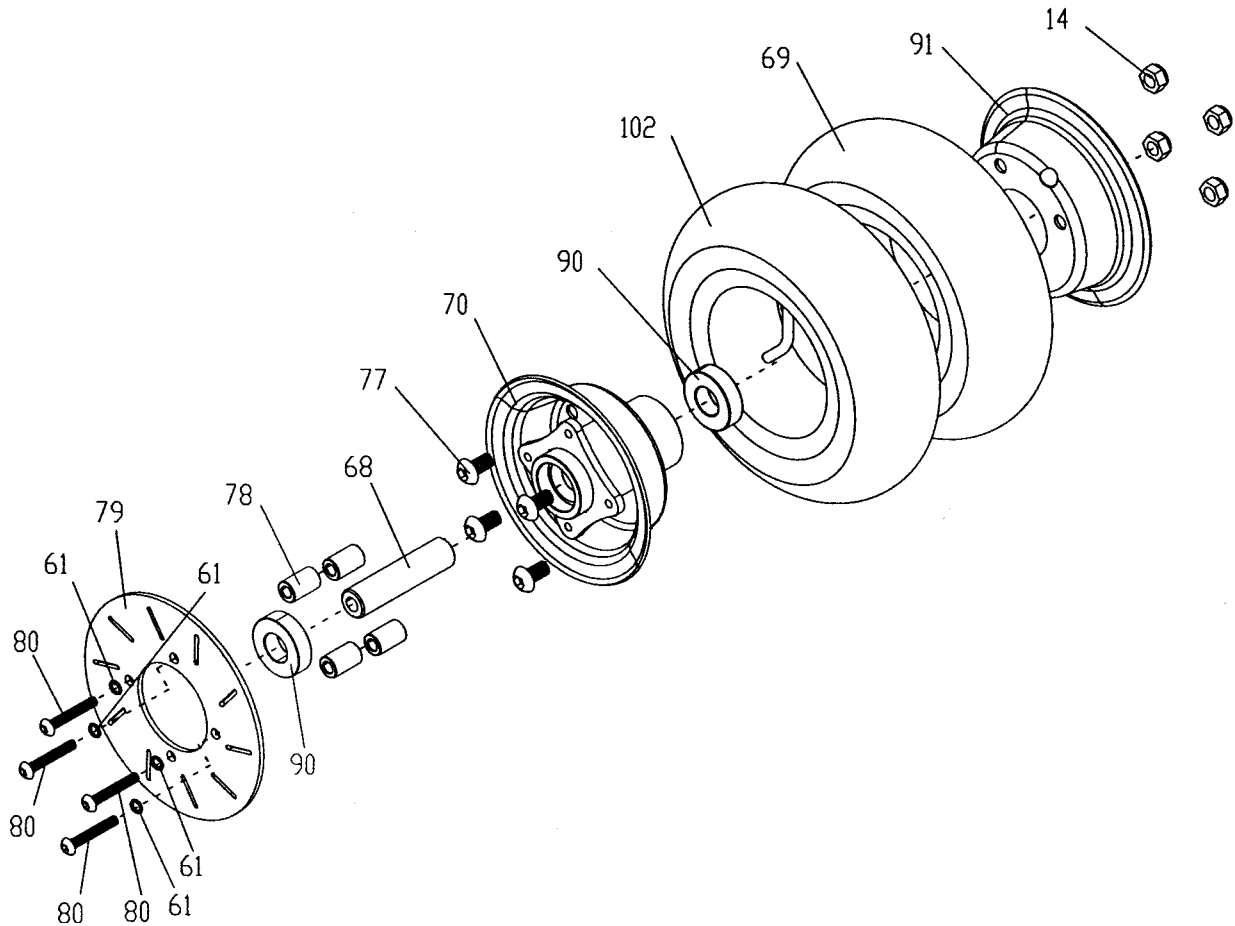

ITEM	PART NUMBER	DESCRIPTION	QTY	COMMENTS
4-14	30821	NUT, M8xP1.25	4	
4-61	30830	WASHER, SPRING M6	4	
4-68	30827	SPACER, T-789	1	
4-69	30823	TIRE, 10"	1	
4-70	30825	HUB, (WELD)	1	
4-77	30826	BOLT, M8xP1.25x15	4	
4-78	30828	SPACER, BRAKE, T-790	4	
4-79	30829	DISC, BRAKE	1	
4-80	30831	BOLT, M6xP1.0x32	4	
4-90	30883	BEARING, 6200-2RS	2	
4-91	30822	HUB, (5 HOLES)	1	
4-102	30911	TUBE, TIRE	1	

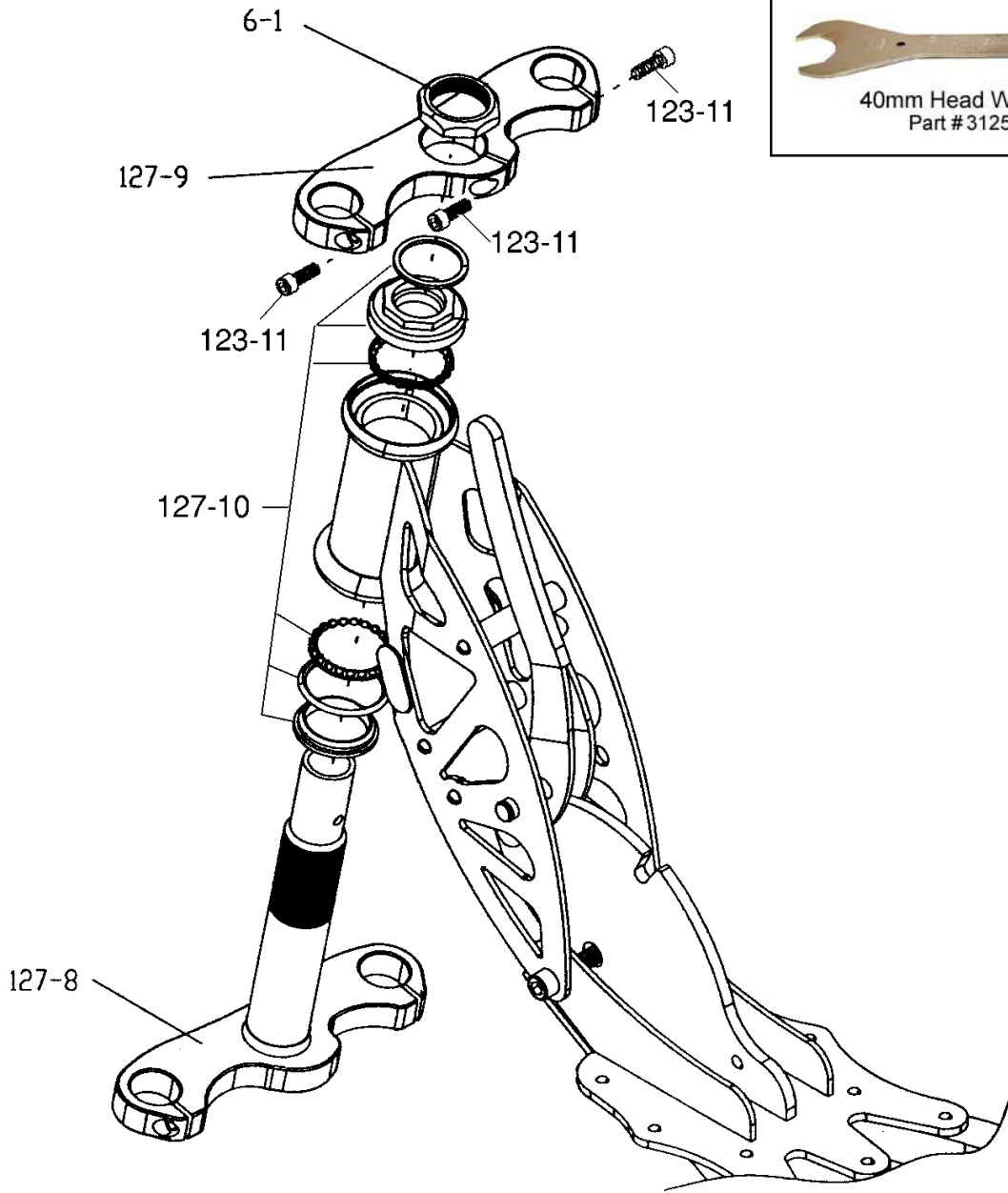

ITEM	PART NUMBER	DESCRIPTION	QTY	COMMENTS
5-6-1	31554	OCTAGON 1.25"	1	
5-123-11	31730	SCREW, CHROME	5	
5-127-8	31580	TRIPLE CLAMP, BOTTOM	1	
5-127-9	31581	TRIPLE CLAMP, TOP	1	
5-127-10	31671	HEAD BEARING KIT	1	

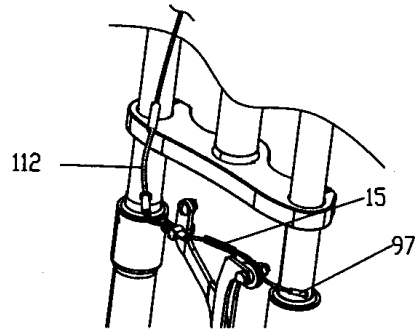
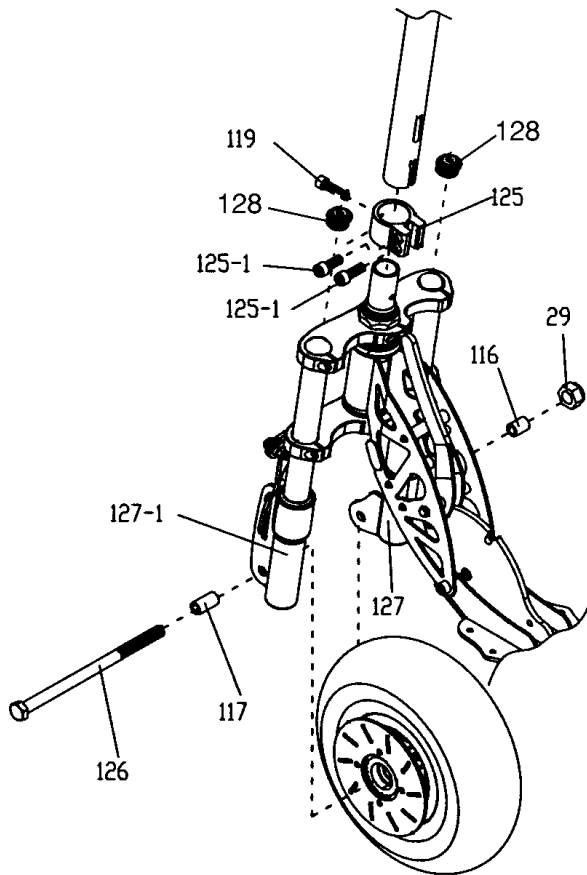

ITEM	PART NUMBER	DESCRIPTION	QTY	COMMENTS
6-15	31080	SPRING,S-043	1	
6-29	30880	NUT,M10xP1.5	1	
6-97	31082	CAP,CABLE END	1	
6-112	31665	BRAKE WIRE CONDUIT	1	
6-116	31667	SPACER	1	
6-117	31666	SPACER	1	
6-119	31668	SCREW	1	
6-125	31569	HANDLE STEM CONNECTOR	1	
6-125-1	31669	SCREW	2	
6-126	31571	BOLT,M10xP1.5x160	1	
6-127	31572	SHOCK,(R)	1	Caution - Do not disassemble shocks! Extreme pressure and not serviceable!
6-127-1	31573	SHOCK,(L)	1	
6-128	31706	NUT, TOP, TRIPLE CLAMP	2	

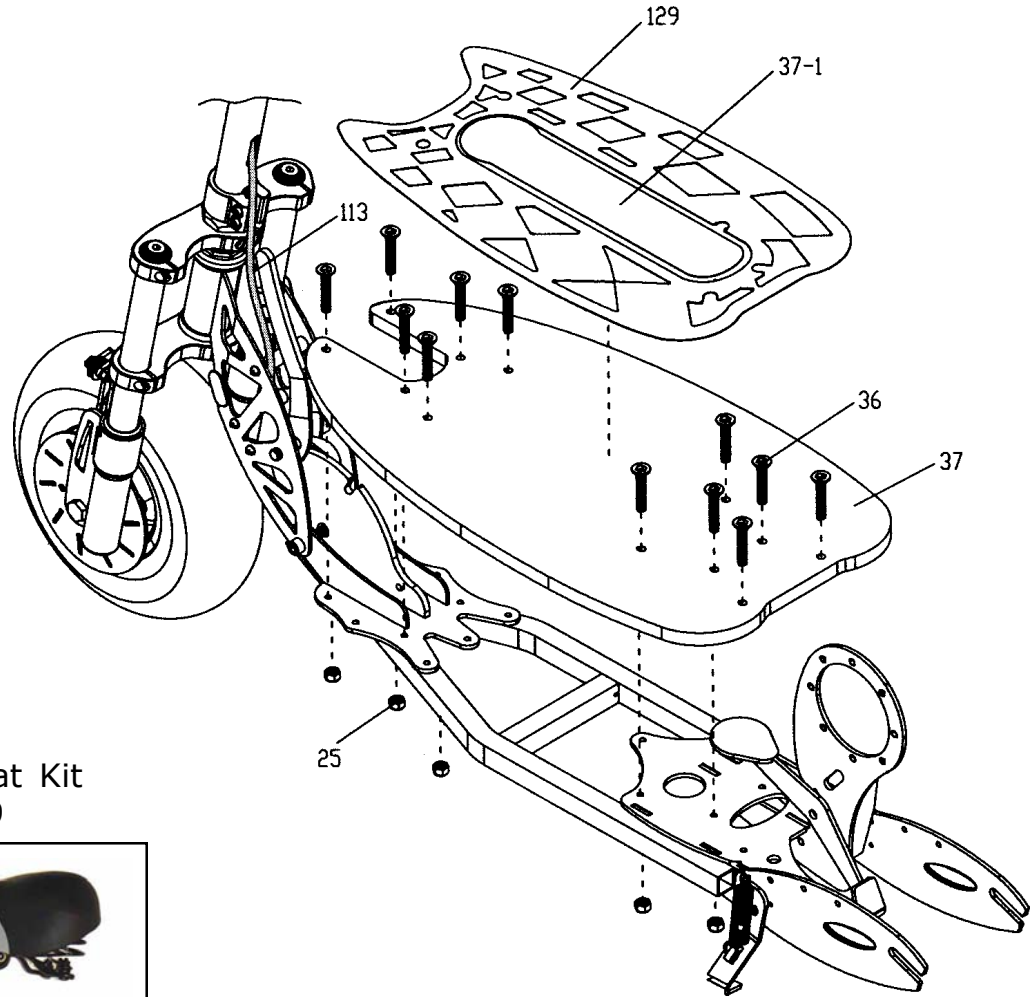

Optional Seat Kit
#31699



ITEM	PART NUMBER	DESCRIPTION	QTY	COMMENTS
7-25	30936	NUT, M6xP1.0	5	
7-36	30912	SCREW, BOARD	12	
7-37	31083	DECK, WOOD, PAVERUNNER 350	1	
7-37-1	31672	DECAL, DECK, PAVERUNNER	1	
7-129	31673	GRIP TAPE, PAVERUNNER	1	

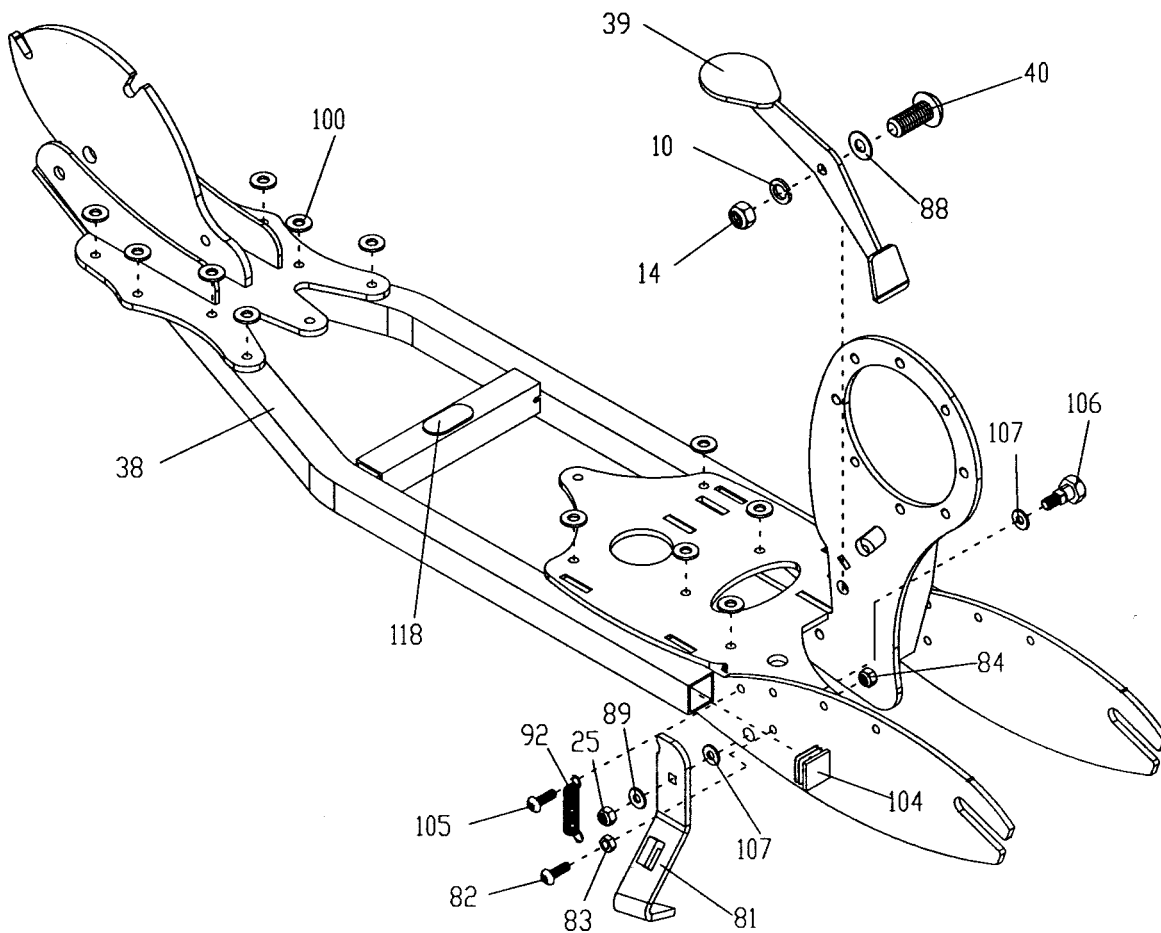

ITEM	PART NUMBER	DESCRIPTION	QTY	COMMENTS
8-10	30819	WASHER, SPRING	1	
8-14	30821	NUT, M8xP1.25	1	
8-25	30936	NUT, M6xP1.0	1	
8-38	31683	FRAME, PAVERUNNER, BLUE	1	
8-39	30817	PEDAL, REAR BRAKE	1	
8-40	30816	BOLT, K-236	1	
8-81	30812	STAND, KICK	1	
8-82	30810	BOLT, M5xP0.8x15	1	
8-83	30936	NUT, M6xP1.0	1	
8-84	30809	NUT, M5xP0.8	1	
8-88	30818	WASHER	1	
8-89	30813	WASHER	1	
8-92	30811	SPRING, KICK STAND	1	
8-100	30815	WASHER, RUBBER	14	
8-104	31087	CAP, FLAT	1	
8-105	30810	BOLT, M5xP0.8x15	1	
8-106	31675	BOLT	1	
8-107	31676	WASHER	2	
8-118	31664	PAD, CUSHION	1	

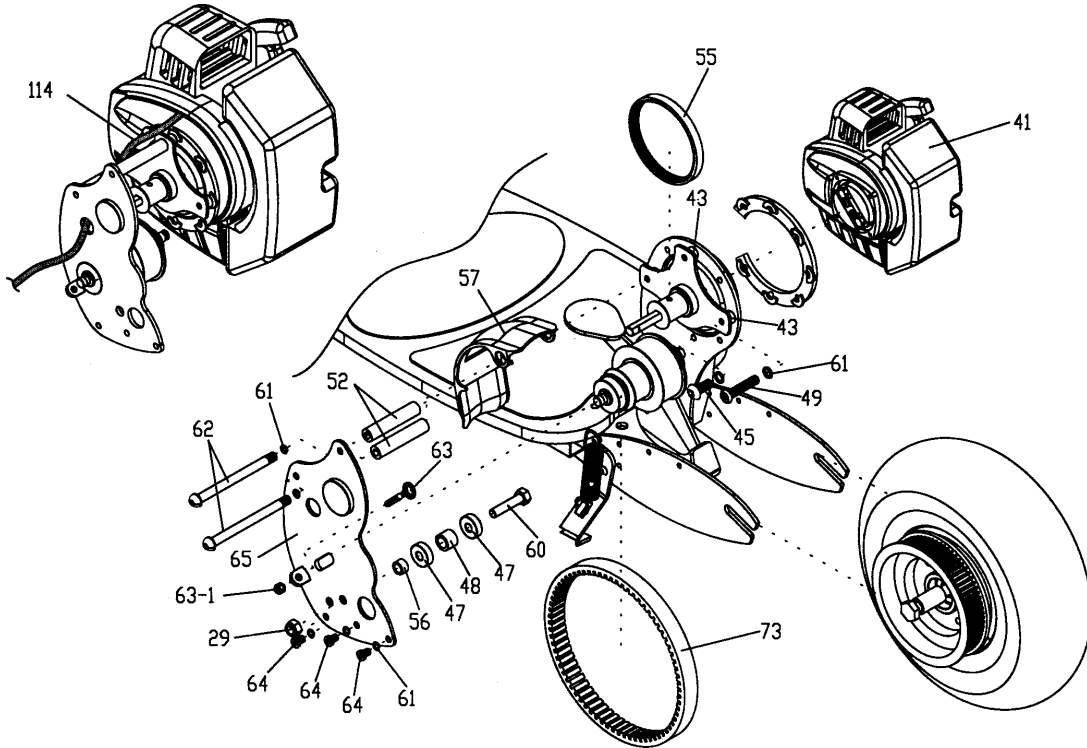

Belt Adjustment / Replacement Procedures

ITEM	PART NUMBER	DESCRIPTION	QTY	COMMENTS
9-29	30880	NUT,M10xP1.5	1	
9-41	TC-355	Complete Replacement Engine,35cc	1	
9-41	PF-4000	Complete Replacement Engine,40cc	1	
9-41	TC-4700	Complete Replacement Engine,47cc	1	
9-43	30917	SPACER,SHORT	3	
9-45	31150	BOLT,M6xP1.0x25,RD HD	1	
9-47	30834	BEARING,6000-2RS	2	
9-48	31091	SPACER,T-804	1	
9-49	31383	BOLT,M6XP1.0X35,RD HD	1	
9-52	31092	SPACER,T-693	2	
9-55	30923	BELT,CLUTCH,(SMALL)	1	
9-56	31093	SPACER,T-797	1	
9-57	30915	FENDER	1	
9-60	31094	BOLT,M10xP1.5x45	1	
9-61	30830	WASHER,SPRING M6	7	
9-62	31095	BOLT,K-222	2	
9-63	31096	SCREW,M6xP1.0x40	2	
9-63-1	31677	NUT	1	
9-64	31097	BOLT,M6xP1.0x10	3	
9-65	31684	PLATE,SUPPORT,BLUE	1	
9-73	30921	BELT,DRIVE,(LARGE)	1	
9-93	30959	MOUNTING RING	1	



Custom Gold Valve Caps
Part # 31257



Custom Chrome Valve Caps
Part # 31256

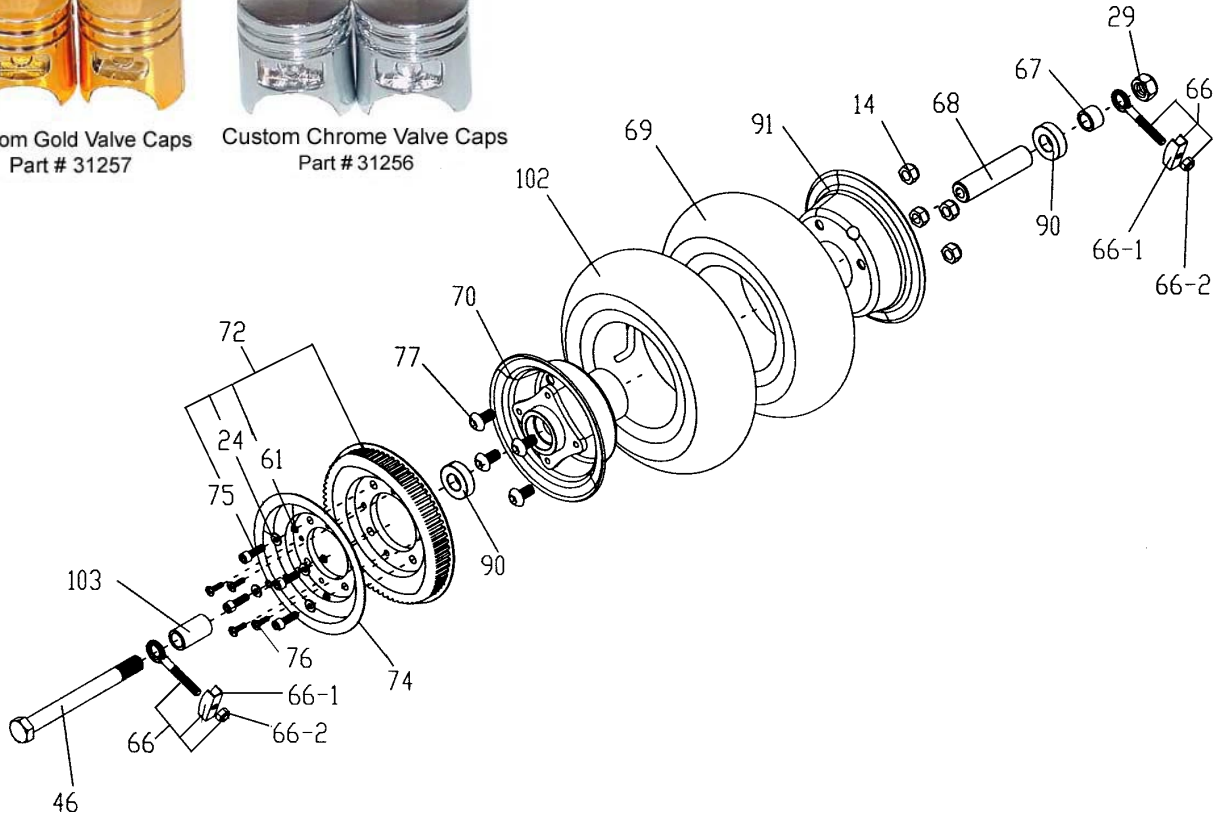

ITEM	PART NUMBER	DESCRIPTION	QTY	COMMENTS
10-14	30821	NUT,M8xP1.25	4	
10-24	31100	WASHER	4	
10-29	30880	NUT,M10xP1.5	1	
10-46	30891	BOLT,AXLE 10x145	1	
10-61	30830	WASHER,SPRING M6	4	
10-66	30881	SCREW,REAR AXLE TENSION	2	
10-66-1	31679	BASE,ADJUSTER	1	
10-66-2	31680	NUT,ADJUSTER	1	
10-67	30886	SPACER,REAR WHEEL,(L)	1	
10-68	30884	SPACER	1	
10-69	30823	TIRE,10"	1	
10-70	30825	HUB,(WELD)	1	
10-72	30887	PULLEY,REAR DRIVE	1	
10-74	30888	GUARD,BELT	1	
10-75	30889	BOLT,6x20	4	
10-76	30890	SCREW	4	
10-77	30826	BOLT,M8xP1.25x15	4	
10-90	30883	BEARING,6200-2RS	2	
10-91	30822	HUB,(5 HOLES)	1	
10-102	30911	TUBE,TIRE	1	
10-103	30882	SPACER,REAR WHEEL (R)	1	

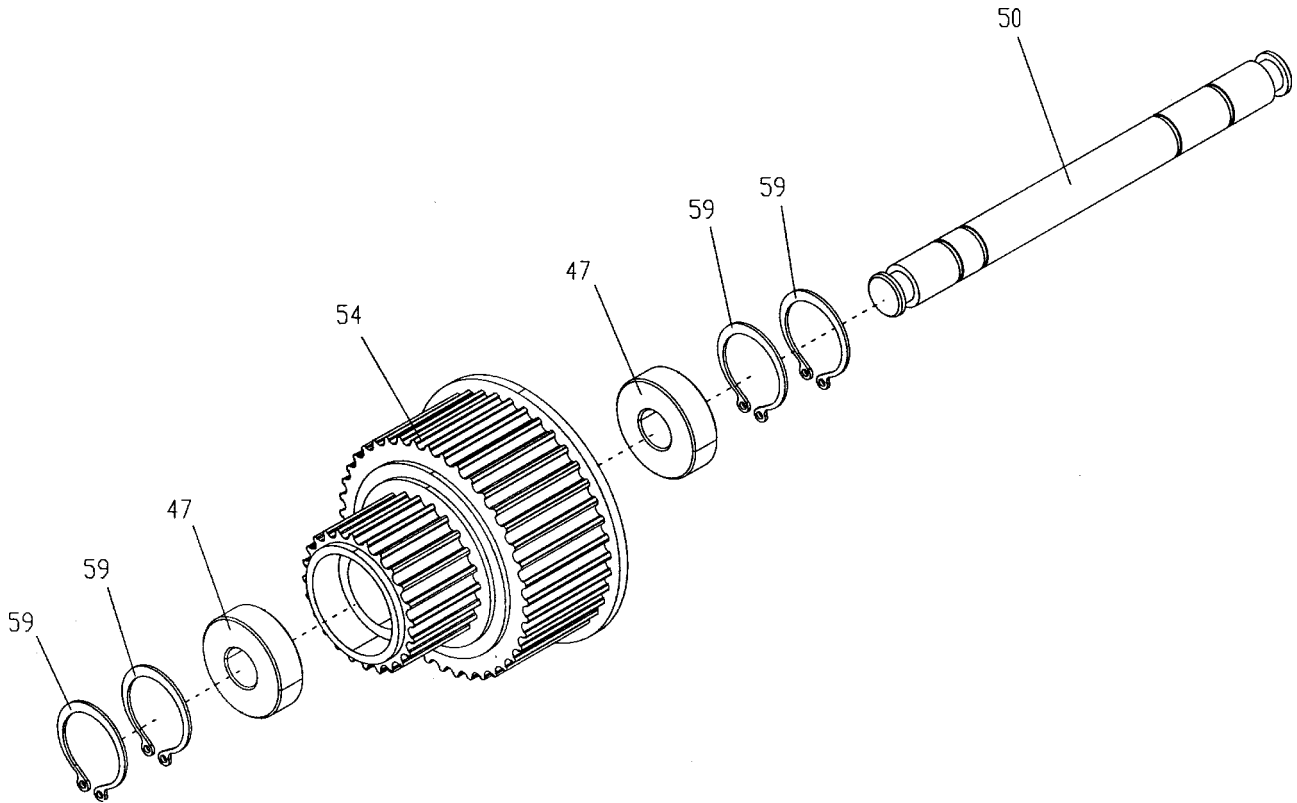

ITEM	PART NUMBER	DESCRIPTION	QTY	COMMENTS
11-47	30834	BEARING,6000-2RS	2	
11-50	30832	SHAFT,T-796	1	
11-54	30835	GEAR,LARGE	1	
11-59	30833	RING,C	4	

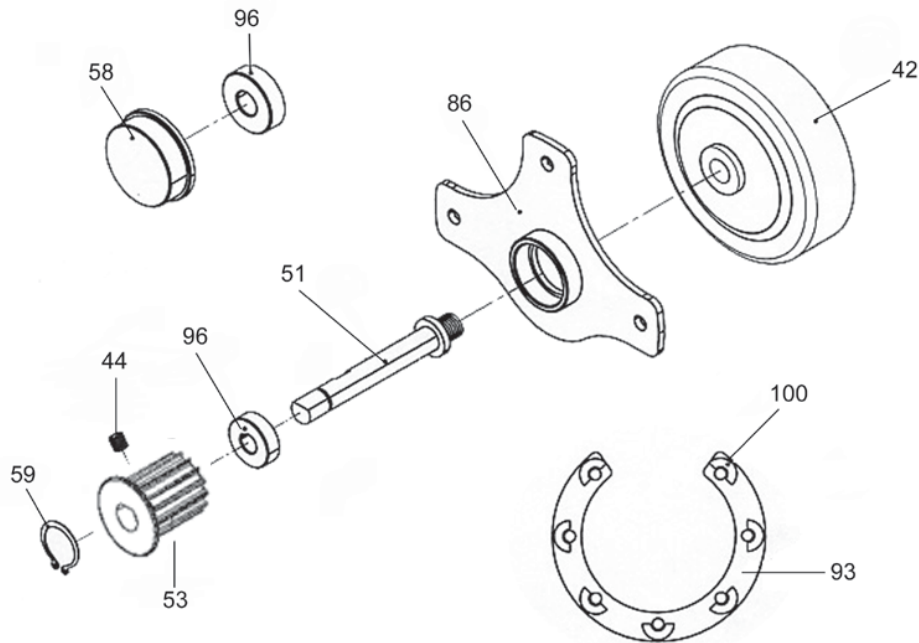

Power & Speed Sprockets



- 32099 POWER SPROCKET,13TH
- 32100 POWER SPROCKET,14TH
- 32101 SPEED SPROCKET,16TH
- 32102 SPEED SPROCKET,17TH
- 32103 SPEED SPROCKET,18TH

ITEM	PART NUMBER	DESCRIPTION	QTY	COMMENTS
12-42	30836	DRUM,CLUTCH	1	
12-44	30839	BOLT,M5xP0.8x5	1	
12-51	30838	SHAFT,CLUTCH	1	
12-51	70100	SHAFT,CLUTCH,LONG,4in	1	
12-53	30840	SPROCKET,(SMALL)	1	
12-58	30842	HOLDER,BEARING	1	
12-59	30841	RING,C	1	
12-86	30837	PLATE,MOUNTING	1	
12-93	30959	MOUNTING RING	1	
12-96	30834	BEARING,6000-2RS	2	
12-100	30844	WASHER,RUBBER	4	

CYLINDER, PISTON, IGNITION • FIGURE 1

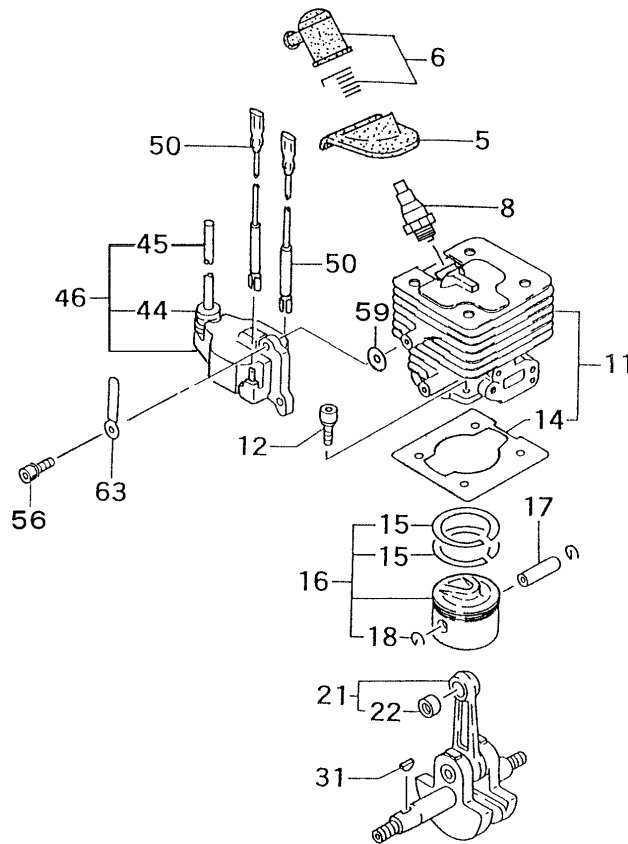

ITEM	PART NUMBER	DESCRIPTION	QTY	COMMENTS
1-5	25504200200	COVER, SPARK PLUG, RUBBER	1	
1-6	15711666900	CAP, SPARK PLUG ASS'Y	1	
1-8	01804075200	PLUG, SPARK	1	
1-11	0010440590	SET, CYLINDER	1	
1-12	99461050204	BOLT, HEX, HOLE, 5X20, S	4	
1-14	0170440020	GASKET, CYLINDER	1	
1-15	04104050200	RING, PISTON	2	
1-16	0300440090	SET, PISTON	1	
1-17	0370100020	PIN, PISTON	1	
1-18	03905004200	CIRCLIP, PISTON PIN	2	
1-21	0460440080	CRANKSHAFT	1	
1-22	99962101004	BEARING, NEEDLE, F1010B	1	
1-31	06802000200	KEY, WOODRUFF, 3X13X5	1	
1-44	56020517200	CAP, RUBBER	1	
1-45	1782054320	CORD, HIGH TENSION	1	
1-46	1672054390	ASSY, IGNITION COIL	1	
1-50	1790007080	STOP CORD, 220MM	2	
1-56	99011040182	SCREW, 4X18	2	Before S/N U112140
1-56	99416040183	SCREW 4X18/WS	2	S/N U112141 and after
1-59	1820186A201	WASHER, SPECIAL	2	
1-63	19805015800	CLAMP, CORD	1	

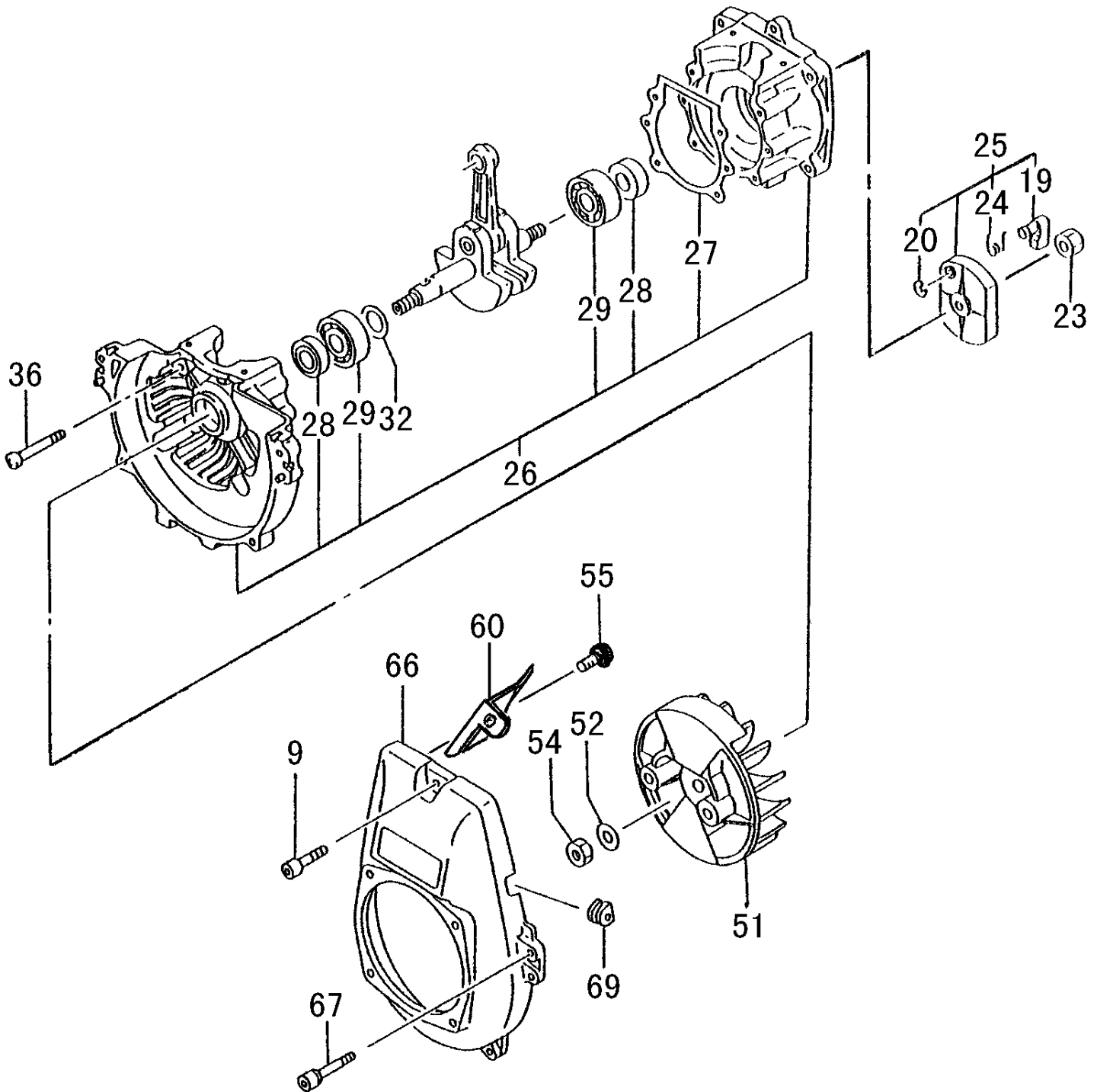

CRANKCASE, FLYWHEEL, STARTER PULLEY • FIGURE 2

ITEM	PART NUMBER	DESCRIPTION	QTY	COMMENTS
2-9	99463050204	BOLT, HEX 5X20	1	
2-19	7880162V20	PAWL, STARTER	1	
2-20	99355050000	RING, STOP, 5	1	
2-23	99111100013	NUT, 10	1	
2-24	7900162V200	SPRING, PAWL, STARTER	1	
2-25	7980422090	PAWL, STARTER ASS'Y	1	
2-26	0720440090	CASE, CRANK	1	Before S/N U207704
2-26	0720440091	CASE, CRANK	1	S/N U207705 and after
2-27	0900440020	GASKET, CRANKCASE	1	*Crankcase assy includes bearings, seals and gaskets.
2-28	99966152511	SEAL, OIL, #VE 15X25X7	2	
2-29	99961620200	BEARING, BALL, #6202	2	
2-32	07102007200	SHIM, 15.2X20X.05	V	*Shims are "as needed" to obtain
2-32	07102007210	SHIM, 15.2X20X.10	V	correct side clearance
2-32	07102007220	SHIM, 15.2X20X.15	V	
2-32	07111600230	SHIM, 16X21X.20	V	
2-32	07111600240	SHIM, 16X21X.30	V	
2-36	99461050304	BOLT, HEX, 5X30S	4	
2-51	1552053880	ROTOR, MAGNETO	1	
2-52	99201100011	WASHER, 10	1	
2-54	99101100011	NUT, 10	1	
2-55	99414050101	SCREW, S, 5X10	1	
2-60	1320440020	DEFLECTOR, AIR	1	
2-66	1120440021	CASE, FAN (ORANGE)	1	
2-66	1120441321	CASE, FAN (POLISHED)	1	
2-67	99461050204	BOLT, HEX, HOLE, 5X20, S	4	
2-69	20311660200	GROMMET, PRIMARY CORD	1	

MUFFLER, MUFFLER COVER • FIGURE 3



40cc Tanaka Power Pipe
Part #: 31879

Click on the pipe for
more information !!

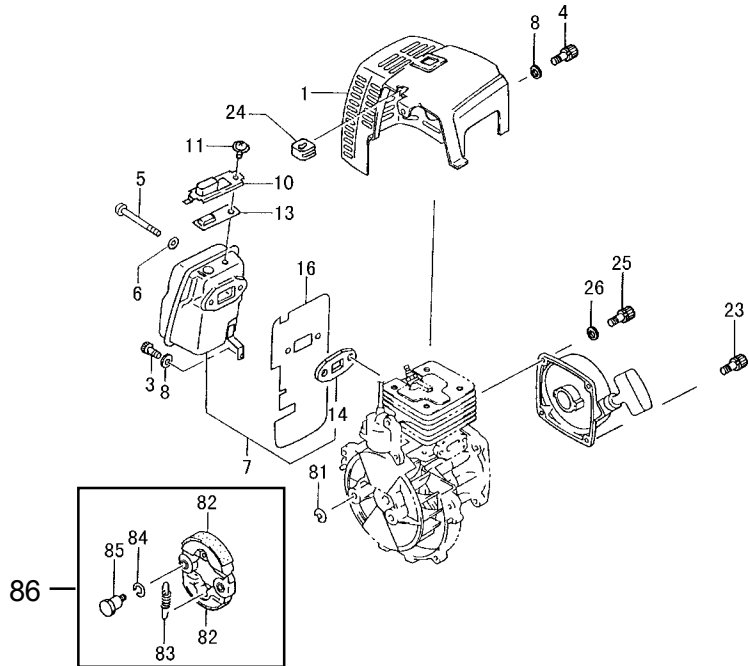

ITEM	PART NUMBER	DESCRIPTION	QTY	COMMENTS
3-1	7380440A21	PROTECTOR,MUFFLER	1	
3-3	99461050124	BOLT,HEX,5X12S	1	
3-4	99461050164	BOLT,HEX,5X16,S	1	Before S/N U207704
3-5	99053060653	SCREW,HEX,6X65	2	
3-6	99201060011	WASHER,6	2	
3-7	7040440090	SET,MUFFLER	1	
3-8	99201050061	WASHER,5	2	Before S/N U207704
3-8	99201050061	WASHER,5	1	S/N U207705 and after
3-10	7210440020	PIPE,TAIL	1	
3-11	99434040081	SCREW,4X8/S	1	
3-13	7320440020	ARRESTER,SPARK	1	
3-14	73704230200	GASKET,MUFFLER	1	
3-16	1330440020	SHIELD,HEAT	1	
3-23	99463050204	BOLT, HEX 5X20	4	Before S/N U207704
3-23	99463050204	BOLT, HEX 5X20	2	S/N U207705 and after
3-24	2030604A202	GROMMET	1	
3-25	99461050254	BOLT,HEX HOLE,5X25S	2	S/N U207705 and after
3-26	99201050061	WASHER,5	2	S/N U207705 and after
3-81	35910112203	WASHER,CLUTCH B	2	
3-82	2900420081	SHOE,CLUTCH	2	
3-83	34204200200	SPRING,CLUTCH	1	
3-84	99204100030	WASHER,WAVE,10	2	
3-85	35704201200	BOLT,CLUTCH STEP	2	
3-86	30790	CLUTCH ASS'Y	1	
N/A	32014	SPRING,POWER PIPE,SHORT	1	Power pipe hardware, not shown
N/A	32015	SPRING,POWER PIPE,LONG	2	Power pipe hardware, not shown
N/A	32016	SPACER,POWER PIPE	2	Power pipe hardware, not shown
N/A	32017	SCREW,POWER PIPE	4	Power pipe hardware, not shown
N/A	32018	WASHER,POWER PIPE	4	Power pipe hardware, not shown

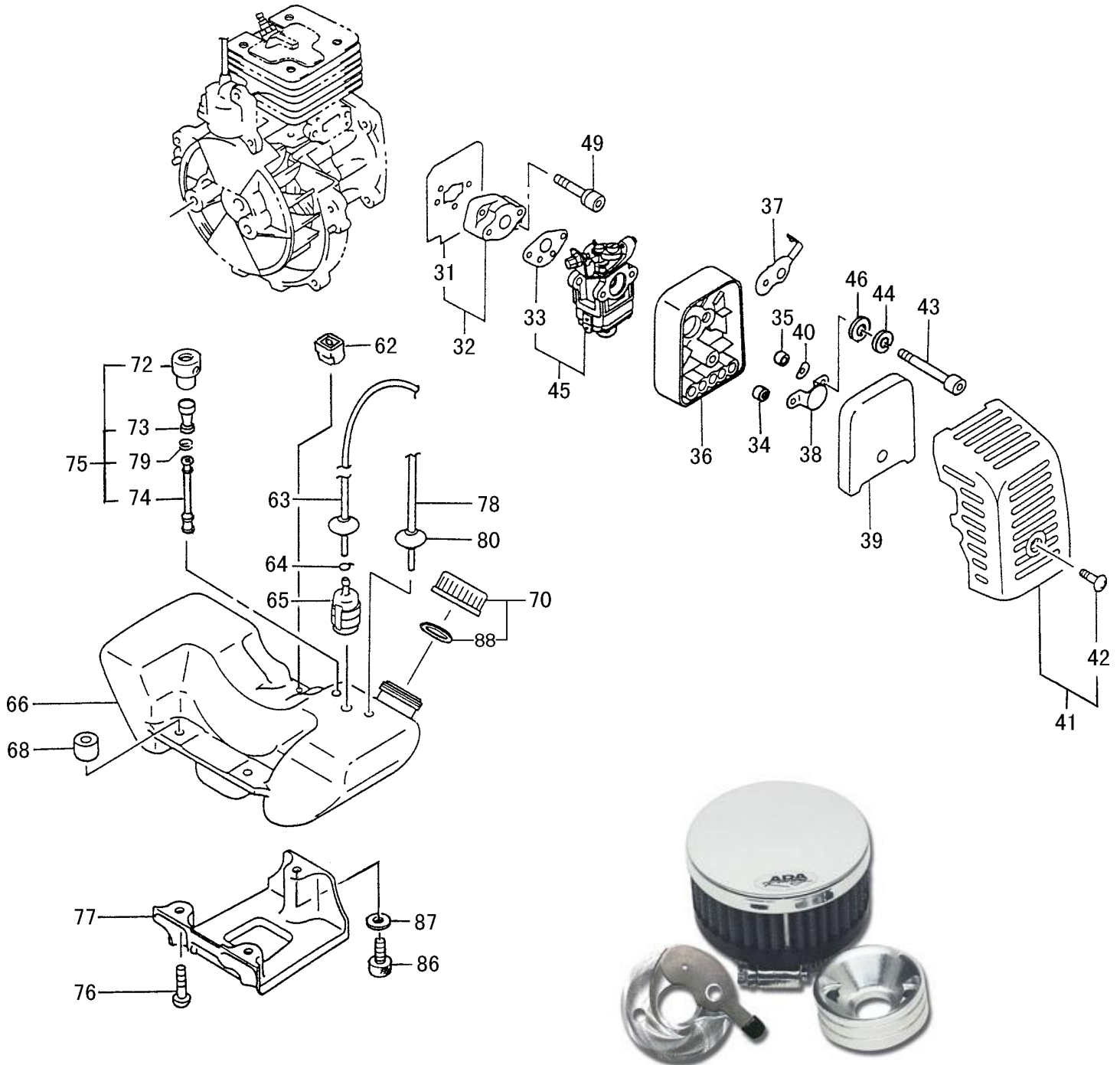

MOBY XL Air Filter Kit

Part#: 30941

ITEM	PART NUMBER	DESCRIPTION	QTY	COMMENTS
4-31	4030430020	GASKET,INLET MANIFOLD	1	
4-32	4040430090	SET,CARB INSULATOR	1	
4-33	4020430020	GASKET,CARBURETOR	1	
4-34	4530637C200	COLLAR	1	
4-35	4700138020	COLLAR,CLEANER	1	
4-36	4230138082	BODY,CLEANER	1	
4-37	5280138021	VALVE,CHOKE	1	
4-38	47601700200	BOARD,BLOW OVER CHECK	1	
4-39	4460138020	ELEMENT,CLEANER	1	
4-40	99204080030	WASHER,8	1	
4-41	4520138091	COVER,CLEANER,ASSY	1	
4-42	3800637C200	BOLT,CLEANER COVER	1	
4-43	99011050602	SCREW,5X60	2	
4-44	99210050012	WASHER,S,5	2	
4-45	4550440090	CARBURETOR	1	
4-46	78600601200	WASHER,RECOIL STARTER	2	
4-49	99416050253	BOLT,HEX HOLE,5X25WS	2	
4-62	6490168020	COLLAR,TANK FIXING	1	S/N U207705 and after
4-63	22301251901	PIPE,FUEL,3X5X230	1	
4-64	68000731201	CLIP 6.3	1	
4-65	67501630900	FILTER,FUEL	1	
4-66	5910440021	TANK,FUEL (ORANGE)	1	
4-66	5910441321	TANK,FUEL (WHITE)	1	
4-68	6590430020	COLLAR C	3	
4-70	5950656B90	CAP,FUEL BLACK,NON VENT	1	
4-73	6463252L90	AIR VENT VALVE ASSY	1	
4-74	5650440020	PIPE,AIR VENT	1	
4-75	5640661190	VENT,AIR ASSY	1	
4-76	99463050204	BOLT, HEX 5X20	3	Before S/N U207704
4-76	99463050204	BOLT, HEX 5X20	2	S/N U207705 and after
4-77	9400430020	STAND,ENGINE	1	
4-78	70003005100	PIPE,FUEL,3X5X100	1	
4-79	68000206200	CLIP,5.5	1	
4-80	22206300200	GROMMET,FUEL PIPE	1	
4-86	99461050304	BOLT,HEX,5X30S	1	S/N U207705 and after
4-87	99201050061	WASHER,5	1	S/N U207705 and after
4-88	6420608A200	GASKET,TANK CAP	1	

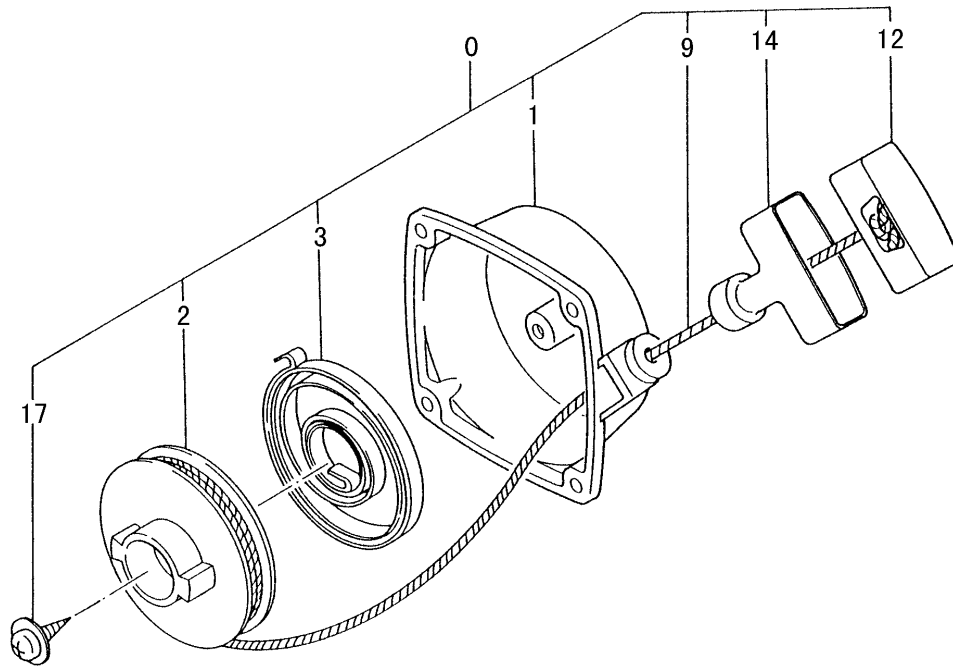

Billet Starter Handles

Part#: **Blue** - 31352 / **Black** - 31358

Polished - 31357 / **Red** - 31356

ITEM	PART NUMBER	DESCRIPTION	QTY	COMMENTS
5-0	7620422090	STARTER,RECOIL ASS'Y	1	
5-1	7720422080	BODY,RECOIL STARTER	1	
5-2	7690422020	REEL,STARTER ROPE	1	
5-3	7790422020	SPRING,RECOIL	1	
5-9	7830422020	ROPE,STARTER	1	
5-12	8350422020	CAP,HANDLE	1	
5-14	7850422020	HANDLE,STARTER	1	
5-17	8390422020	SCREW,SET	1	

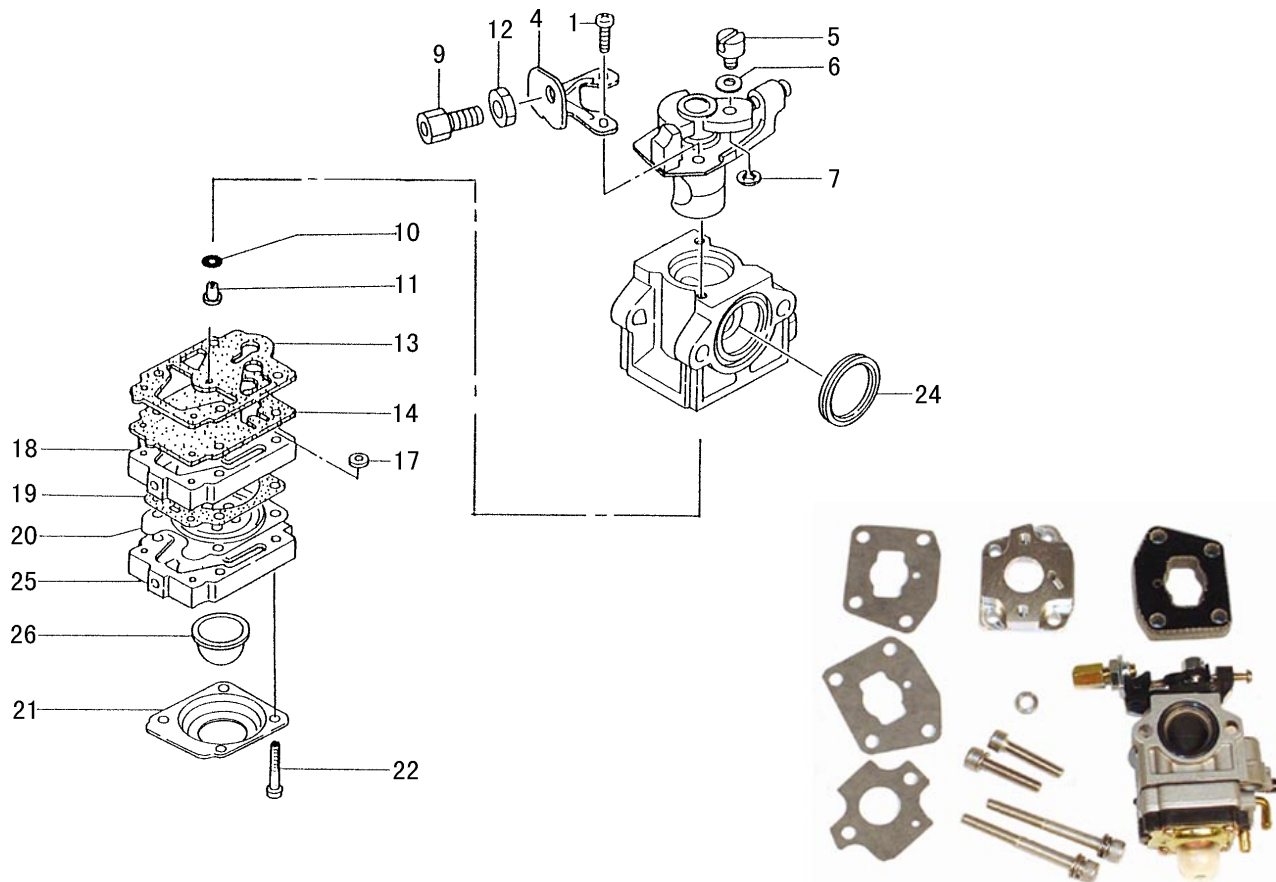

40cc HP Carburetor Kit
Part#: 31283

ITEM	PART NUMBER	DESCRIPTION	QTY	COMMENTS
6-0	4550440090	SET,CARBURETOR	1	Includes carburetor gasket
6-1	51425100200	SCREW,THROTTLE SET	2	
6-4	54425164200	STAY,ADJUST,CABLE	1	
6-5	53925120200	SWIVEL	1	
6-6	5492516520	WASHER,THRUST	1	~ Contained in Carb Repair Kit
6-7	48925100200	RING,STOP	1	P/N 650-25124-900
6-9	61425137200	ADJUSTER,CABLE	1	(Not available individually)
6-10	55025100200	O-RING	1	
6-11	5992001W44	JET,MAIN,LONG,#44	1	
6-12	99101060013	NUT,6	1	
6-13	~ ~ ~	GASKET,PUMP	1	
6-14	~ ~ ~	DIAPHRAGM,PUMP	1	
6-17	57825007200	SCREEN,INLET	1	
6-18	5752515380	BODY,PUMP	1	
6-19	~ ~ ~	GASKET,DIAPHRAGM	1	
6-20	~ ~ ~	DIAPHRAGM,METERING	1	
6-21	4762515120	COVER,DIAPHRAGM	1	
6-22	5482515120	SCREW,SET	4	
6-24	4310634C200	GASKET,CLEANER	1	
6-25	4422515180	PUMP,PRIMING	1	
6-26	44725108200	BULB,PRIMING	1	

Belt Adjustment



Figure 15

The Moby PowerBoard uses a dual stage, belt driven system to transmit power to the rear wheel. Belts should be regularly inspected for adjustment. Both belts are adjusted with two procedures.

Tighten both belt adjusters on either side of the frame (**Fig. 15**) in equal increments until the small belt has approximately ½ inch of play when measured between the pulleys.

Next, loosen the rear axle lock nut, using a 17mm wrench or socket. Adjust the tension in the larger belt by using the rear wheel adjusters located at the rear of the frame, behind the wheel (**Fig. 16**). The belt should have approximately ½ inch of play. Make sure that the wheel is lined up in the center of the frame.

After adjustment, test ride the unit for a short distance to ensure that the belts ride in the center of their pulleys. If they tend to ride on one side of the pulley(s), adjust the opposite side adjuster until the belt centers on the pulley, being careful to maintain the correct belt tension.

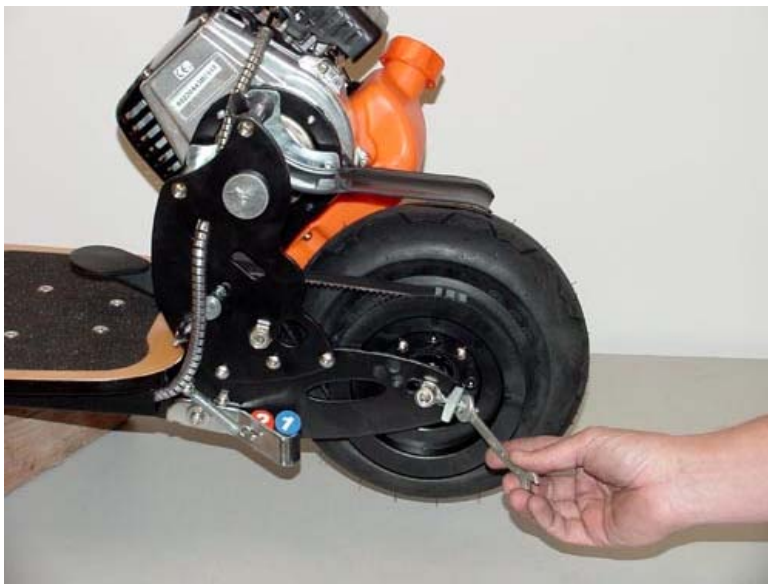

Figure 16

Belt Replacement



Figure 17

Both drive belts carry a similar load, and should wear at a very similar rate. If one of the belts should break or one or both appear worn to the point of needing replacement, it may be preferable to replace both belts simultaneously, as the repair is somewhat involved.



Figure 18

To replace the belts begin by removing the air cleaner cover, and disconnect the throttle wire and stop cord wire from engine.

Next, remove the 2 top engine mount bolts with their spacers, as well as the fender (**Fig. 17**).

Loosen and remove the belt tension adjuster from the left side of the frame, as well as the three screws that secure the left hand side plate to the frame (**Fig. 18**)



Figure 19

With the side plate removed, it is possible to remove both belts from the frontward pulleys. Inspect the pulleys (**Fig. 19**) to ensure that they are not damaged. Also, inspect the bearings on the pulley shaft as well as the support bearing that rides in the side plate. If integrity of any bearings are questionable – install new ones.

If it is necessary to replace the large, rear belt, it will require that the rear wheel be completely removed.

Carefully position new belt(s). Note that the lower section of the large, rear belt must ride on top of the idler arm (with two ball bearings in tandem), protruding from the side plate.

Carefully adjust the tension of the belts as indicated in the previous section.