

Tanaka

Parts Catalog



Brush Cutter

Model: TBC-4500

Grass Trimmer Attachments

TPS-200

Pruning Saw Attachment

The versatile TPS-200 Pruning Saw attachment easily converts Tanaka straight shaft grass trimmers / brushcutters into a powerful pruning saw.



TPS-200 Features:

- 24" Shaft Provides a 98" Overall Length when mounted
- 10" Oregon® Bar & Chain
- Easy-Mount Coupler

To be used with the following Tanaka models:

- AST-7000 / 7000S / 210
- TBC-4500 / 4501 / 2211
- TBC-220 / 240
- TBC-250 / 2501 / 2510 / 265
- TBC-270PF/PN



TPS-EXT Pruning Saw **Extension** (Part # 748511) Add an **extra two feet of reach** with this pruning saw extension that will fit on both the TPS-2510 and TPS-270PN Pruning Saws. In addition, it can be added to Tanaka straight shaft grass trimmers that utilize the TPS-200 Pole Saw Attachment.

TPH-200

Pole Hedge Trimmer Attachment

For added reach and maneuverability, the TPH-200 Pole Hedge Trimmer attachment can be added to several Tanaka straight shaft grass trimmers / brushcutters.



TPH-200 Features:

- 22" Double Sided Cutting Blades
- Articulating / Pivoting Cutting Angle up to 130 degrees.

To be used with the following Tanaka models:

- AST-7000 / 7000S / 210
- TBC-4500 / 4501 / 2211
- TBC-220 / 240
- TBC-250 / 2501 / 2510 / 265
- TBC-270PF/PN

TMC-200

Mini-Cultivator

This simple, easy to install attachment is ideal for quick garden / flower bed weeding and cultivation. For maximum depth, the TMC-200 can dig up to 4 inches into the ground and 6" wide.

With a 49:1 reduction ratio, this heavy duty gear box gives you more tilling power.

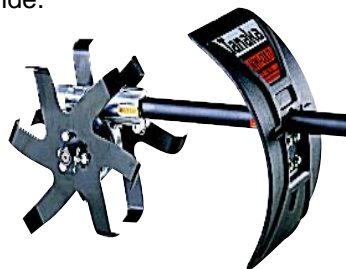

To be used with the following Tanaka models:

- AST-7000 / 7000S / 210
- TBC-4500 / 4501 / 2211
- TBC-220 / 240
- TBC-250 / 2501 / 2510 / 265
- TBC-270PF/PN
- TBC-300 / 3010
- TBC-420PF

All data and specifications are subject to change without notice
For more information, contact:

TBC-4500

OPTIONS AND ACCESSORIES

NYLON LINE



- 746156 .095, Box, 50 ft.
- 746157 .105, Box, 50 ft.
- 746160 .095, 1/2 lb. Box, 143 ft.
- 746161 .105, 1/2 lb. Box, 110 ft.
- 746165 .095, 1 lb. Box, 285 ft.
- 746166 .105, 1 lb. Box, 235 ft.
- 746169 .095, 3 lb. spool, 855 ft.
- 746170 .105, 3 lb. spool, 705 ft.
- 746173 .095, 5 lb. spool, 1425 ft.
- 746174 .105, 5 lb. spool, 1175 ft.

SEMI-AUTO HEAD



746153 PNH-180

Parts List

ET-1201	Body
ET-1206	Cap
ET-1225	Adapter
ET-1205	Spool
ET-1207	Eyelet
ET-1208	Spring
ET-1209	Bump Disk

ALUMINUM MANUAL HEAD



PCH-100
(746180)

PCH-300
(746190)

PERFECT MIX® 2-Cycle Engine Oil

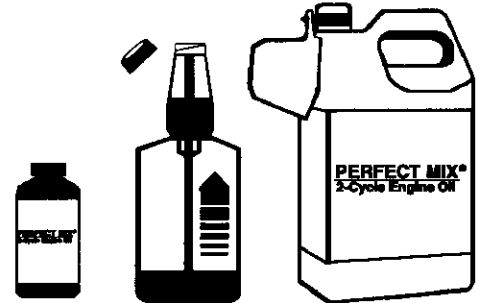

- 700109 2.8 oz. Bottle, 1 Gallon Size (24*)
 - 700108 16 oz. Self-measuring Bottle (24*)
 - 700110 1 Gallon Jug Commercial Size (6*)
- * Case Quantity

SHOULDER STRAPS

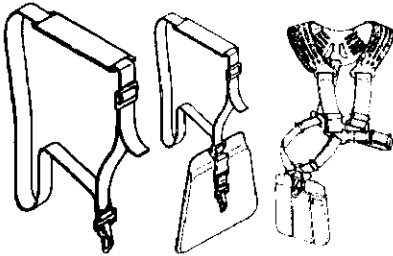

PSS-175 SS-250* SS-400*

* Requires 355-37302-900

TMC-200 CULTIVATOR

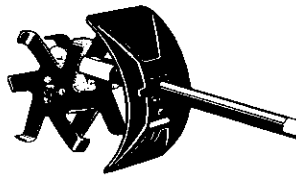

BLADES



- 746101 Weed Blade, 9"X4T
- 746103 Weed Blade, 9"X48T
- 746104 Saw Blade, 9"X80T

MANUALS / CATALOGS

10530	Owner's Manual
12816	Parts Catalog
18912	Service Manual

BLADE SAFETY DISK

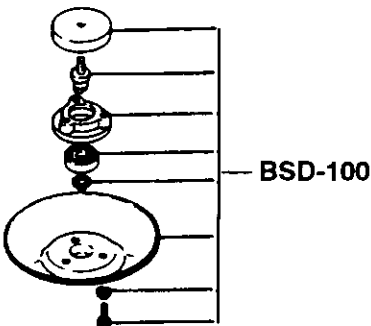

POLE SAW ATTACHMENT

TPS-200

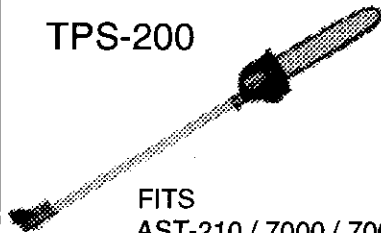

- FITS
- AST-210 / 7000 / 7000S
 - TBC-4500 / 4501 / 2211
 - TBC-220 / 240
 - TBC-250 / 2510 / 265
 - TBC-300 / 3010 / 420PF

SPECIAL TOOLS

009-29323-500	Piston Pin Remover
015-29339-000	Gear Shaft Remover
016-29373-000	Pinion Remover
073-29374-180	Fan Case Remover
037-29379-000	Clutch Remover
070-2000W-501	Carb. Tool Kit
001-29000-000	Tachometer
070-2000W-500	Pressure Tester

FIG.1 ENGINE

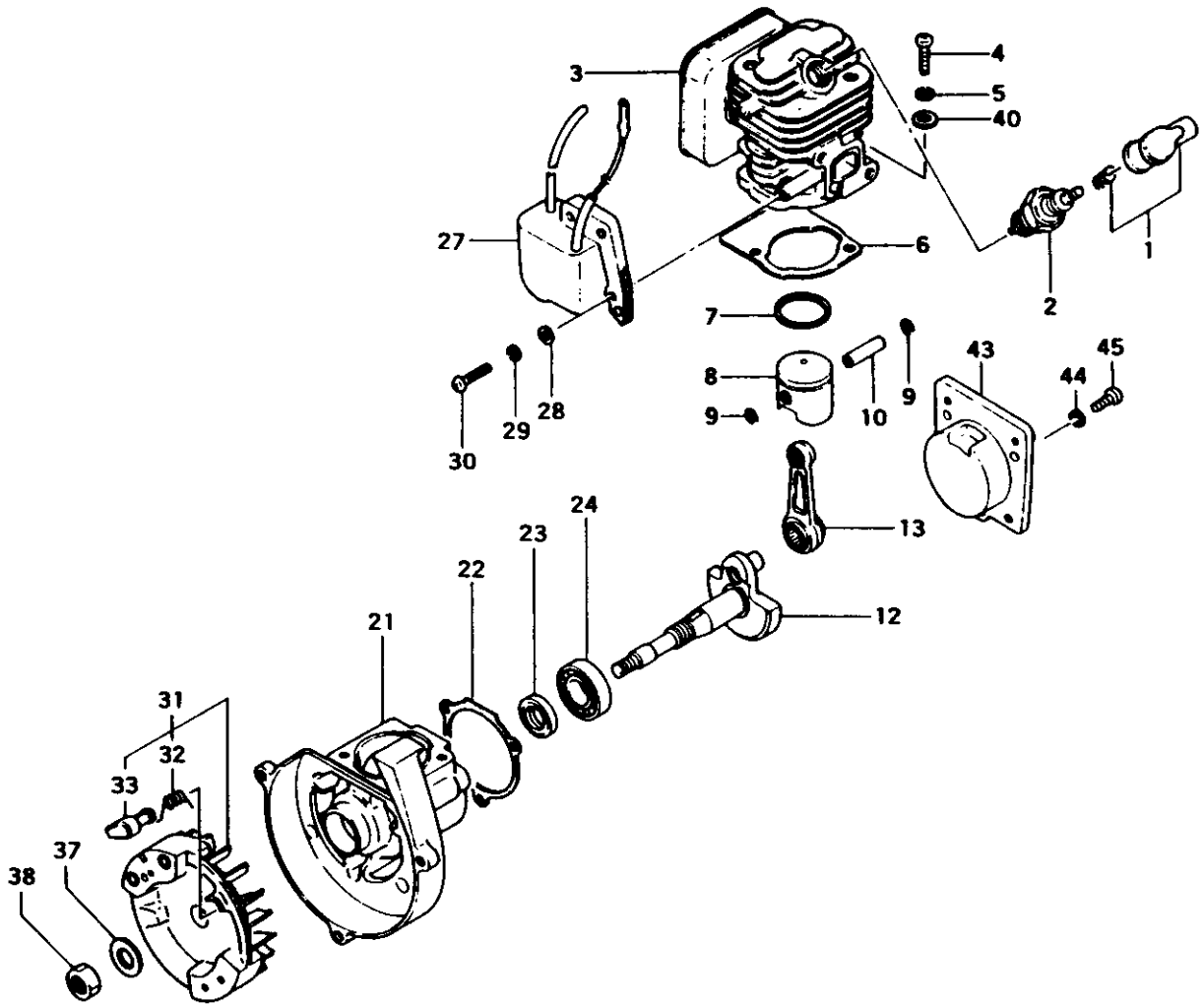

FIGURE 1

TBC-4500 PARTS LISTING

REF.	PART NO.	PART DESCRIPTION	Q	C	S	SERIAL NO.	REMARKS
1	157-01570-900	CAP,SPARK PLUG,ASS'Y	1		C		
2	018-11660-21	PLUG,SPARK	1		B		
3	002-00025-20	CYLINDER	1		B		
4	990-11050-221	SCREW,5X22	2		B		
5	992-10050-012	WASHER,S,5	2		A		
6	017-00025-200	GASKET,CYLINDER	1		A		
7	041-00000-210	RING,PISTON,LOWER	1		A		
8	031-00025-20	PISTON	1		D		
9	039-06100-200	CIRCLIP,PISTON PIN	2		A		
10	037-06097-20	PIN,PISTON	1		B		
12	046-00025-80	CRANKSHAFT	1		D		
13	061-00025-800	ROD,CONNECTING	1		C		
21	077-00025-21	CRANKCASE	1		D		
22	090-00025-200	GASKET,CRANKCASE	1		B		
23	999-66152-511	SEAL,OIL,#VE15X25X7	1		A		
24	999-61600-200	BEARING,BALL,#6002	1		B		
27	167-21522-800	COIL,IGNITION	1		C		
28	992-00040-011	WASHER,4	2		B		
29	992-10040-012	WASHER,S,4	2		B		
30	990-11040-201	SCREW,4X20	2		C		
31	155-21522-900	ROTOR,MAGNETO ASS'Y	1		C		
32	790-00025-200	SPRING,PAWL	1		D		
33	788-00025-200	PAWL,STARTER	1		D		
37	992-01120-011	WASHER,12	1		D		
38	991-11120-011	NUT,12	1		A		
40	992-01050-011	WASHER,5	2		A		
43	218-00025-200	COVER,CRANK CASE	1		D	-N214210	
44	992-10050-012	WASHER,S,5	3		A	-N214210	
45	990-11050-161	SCREW,5X16	3		B	-N214210	

* Indicates the part is included in a kit or assembly and is not available individually. Q=Quan. used C=Interchangeability S=Stocking code: A-Fast moving B=Med. fast C=Med. move D=Slow move E=N.L.A. F=Superseded or replaced by a new part

FIG.2 ENGINE COMPONENTS

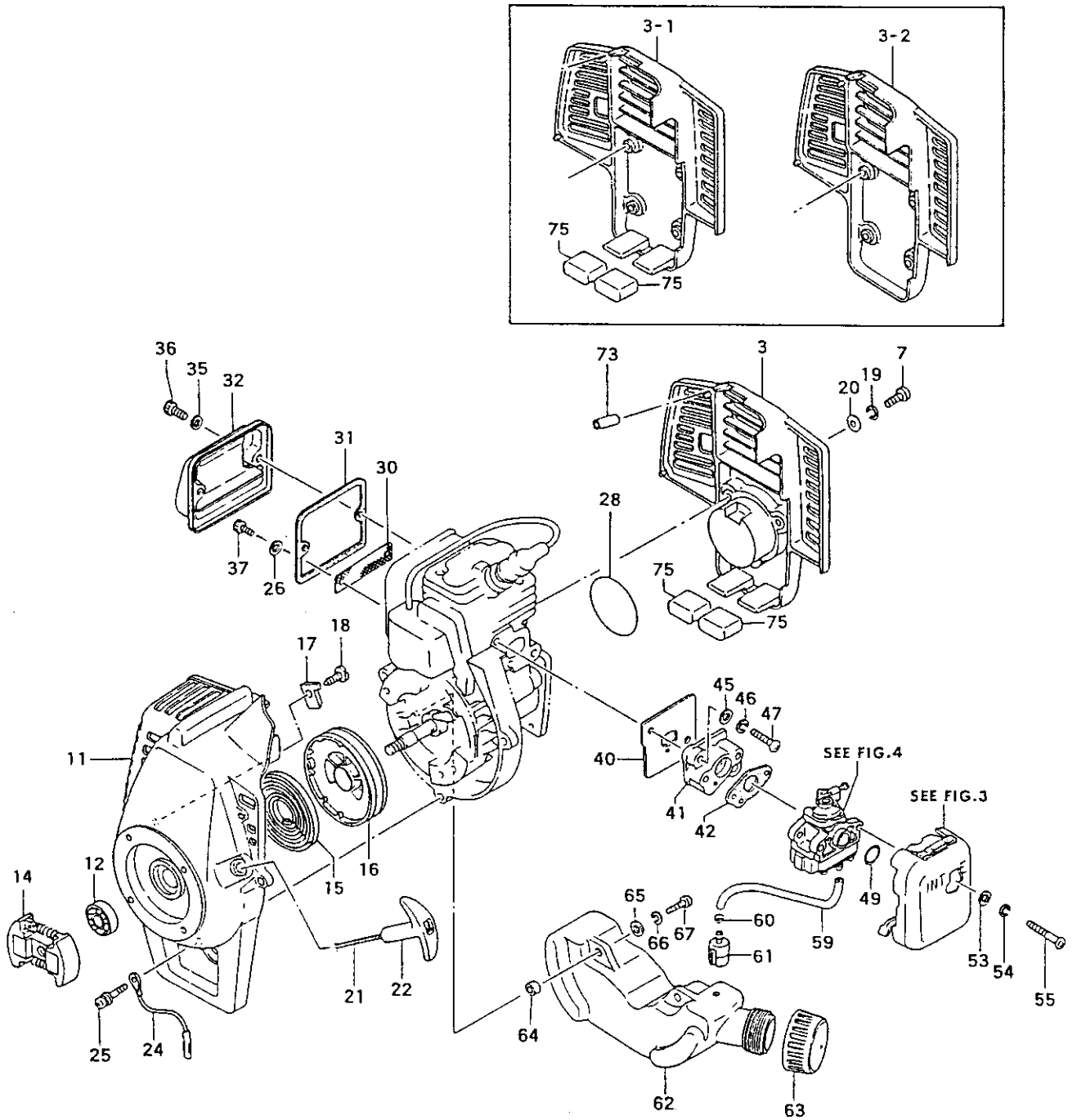

FIGURE 2

TBC-4500 PARTS LISTING

REF.	PART NO.	PART DESCRIPTION	Q	C	S	SERIAL NO	REMARKS
3-2	752-00025-200	PROTECTOR,MUFFLER B	1		D	~K190595	
3-1	752-00025-210	PROTECTOR,MUFFLER B	1		D	~N214210	
3	752-00025-22	PROTECTOR,MUFFLER	1		C	N214211~	
7	994-16050-162	SCREW,5X16/WS	4		D	~N214210	
7	990-11050-161	SCREW,5X16	3		B	N214211~	
11	112-00025-80	CASE,FAN	1		B		
12	999-61600-001	BEARING,BALL,#6000ZZ	1		B		
14	277-0631Q-900	CLUTCH,ASS'Y	1		C		
15	779-0136U-200	SPRING,RECOIL	1		C		
16	774-00025-200	PULLEY,STARTER	1		C		
17	771-00025-200	STAY,PULLEY	2		D		
18	839-00025-200	SCREW,SET	2		D		
19	992-10050-012	WASHER,S,5	3		A		
20	992-01050-011	WASHER,5	3		A		
21	783-06097-200	ROPE,STARTER	1		C		
22	785-06410-200	HANDLE,STARTER	1		C		
24	179-00025-800	CORD,STOP	1		D		
25	994-15050-202	SCREW,5X20/PS	3		C		
26	992-00040-011	WASHER,4	2		B		
28	999-67048-012	O-RING,S-48	1		C		
30	732-00025-200	ARRESTER,SPARK	1		D		
31	739-00025-201	GASKET,MUFFLER	1		C		
32	717-00025-801	BODY,MUFFLER B	1		D		
35	992-00050-011	WASHER,SMALL,5	2		C		
36	990-51050-103	BOLT,HEX.HOLE,5X10	2		C		
37	990-51040-083	BOLT,HEX.HOLE 4X8	2		D		
40	403-0631A-202	GASKET,INLET MANIFOLD	1		A		
41	404-0631A-800	INSULATOR,CARBURETOR	1		B		
42	402-0602K-21	GASKET,CARBURETOR	1		B		
45	992-00050-011	WASHER,SMALL,5	2		C		
46	992-10050-012	WASHER,S,5	2		A		
47	990-11050-221	SCREW,5X22	2		B		
49	999-67015-000	O-RING,P15	1		C		
53	992-00050-011	WASHER,SMALL,5	2		C		
54	992-10050-012	WASHER,S,5	2		A		
55	990-11050-601	SCREW,5X60	2		C		
59	700-13005-130	PIPE,FUEL	1		C		
60	680-00731-201	CLIP	1		B		

* Indicates the part is included in a kit or assembly and is not available individually. Q=Quan. used C=Interchangeability S=Stocking code: A=Fast moving B=Med. fast C=Med. move D=Slow move E=N.L.A. F=Superseded or replaced by a new part

FIGURE 2 cont.

TBC-4500 PARTS LISTING

REF.	PART NO.	PART DESCRIPTION	Q	C	S	SERIAL NO.	REMARKS
61	675-04042-80	FILTER,FUEL	1		A		
62	591-00025-200	TANK,FUEL	1		D	~K190595	
62	591-00025-21	TANK,FUEL	1		C	K190596~	
63	595-0650A-90	CAP,TANK	1		A		
64	659-00801-200	COLLAR,TANK HOLDING METAL	2		C		
65	992-01050-011	WASHER,5	2		A		
66	992-10050-012	WASHER,S,5	2		A		
67	990-11050-181	SCREW,5X18	2		B		
67	994-15050-185	SCREW,5X18	2		D		
73	700-15007-01	PIPE,RUBBER	1		C		
75	655-06400-200	CUSHION,TANK	2		D	K190596~	

* Indicates the part is included in a kit or assembly and is not available individually. Q=Quan. used C=Interchangeability S=Stocking code: A=Fast moving B=Med. fast C=Med. move D=Slow move E=N.L.A. F=Superseded or replaced by a new part

FIG.3 AIR CLEANER

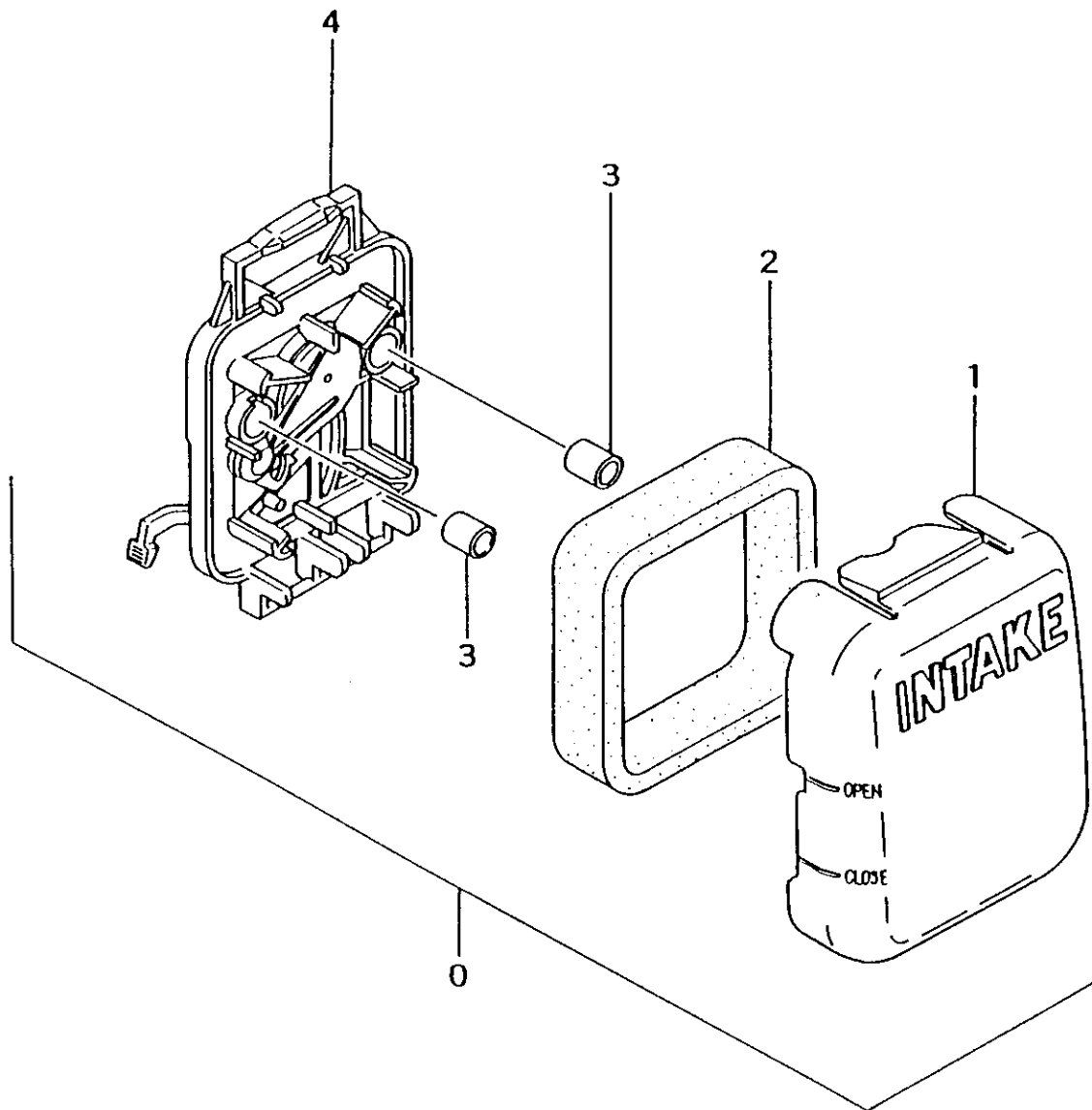

FIGURE 3

TBC-4500 PARTS LISTING

REF.	PART NO.	PART DESCRIPTION	Q	C	S	SERIAL NO	REMARKS
0	410-00025-900	CLEANER,AIR ASS'Y	1		C		
1	424-00025-200	CAP,AIR CLEANER	1		C		
2	446-00025-200	ELEMENT,CLEANER	1		B		
3	470-00025-200	COLLAR	2		D		
4	423-00025-800	BODY,CLEANER,AIR	1		C		

FIG.4 CARBURETOR

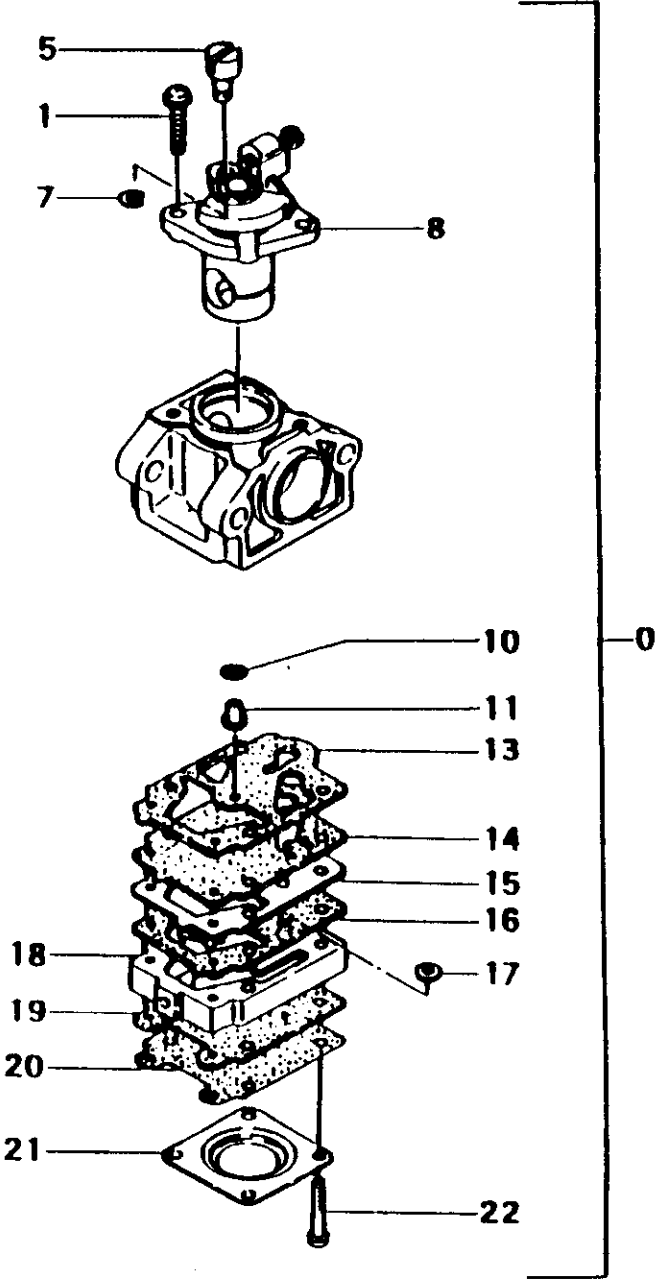

FIGURE 4

TBC-4500 PARTS LISTING

REF.	PART NO.	PART DESCRIPTION	Q	C	S	SERIAL NO.	REMARKS
0	455-25140-900	CARBURETOR,ASSY	1		C		
1	548-25140-200	SCREW,THROTTLE SET	1		D		
5	539-25120-200	SWIVEL	1		D		
7	489-25100-200	RING,STOP	1		D		
8	488-25140-800	VALVE,THROTTLE	1		C		
10	~~~~	*O-RING	1		C		
11	599-2000W-370	JET,MAIN,#37	1		C		* Contained in Carb Repair Kit 650-25140-900 (Not available individually)
13	~~~~	*GASKET,PUMP	1		B		
14	~~~~	*DIAPHRAGM,PUMP	1		B		
15	523-25100-201	PLATE,PUMP	1		C		
16	522-25100-200	PLATE,CIRCUIT	1		C		
17	~~~~	SCREEN,INLET	1		C		
18	575-25140-800	BODY,PUMP	1		D		
19	~~~~	*GASKET,DIAPHRAGM	1		A		
20	~~~~	*DIAPHRAGM,METERING	1		A		
21	476-25004-200	COVER,DIAPHRAGM	1		D		
22	548-25101-200	SCREW,SET	4		D		

* Indicates the part is included in a kit or assembly and is not available individually. Q=Quan. used C=Interchangeability S=Stocking code: A-Fast moving B=Med. fast C=Med. move D=Slow move E=N.L.A. F=Superceded or replaced by a new part

FIG.5 CLUTCH CASE

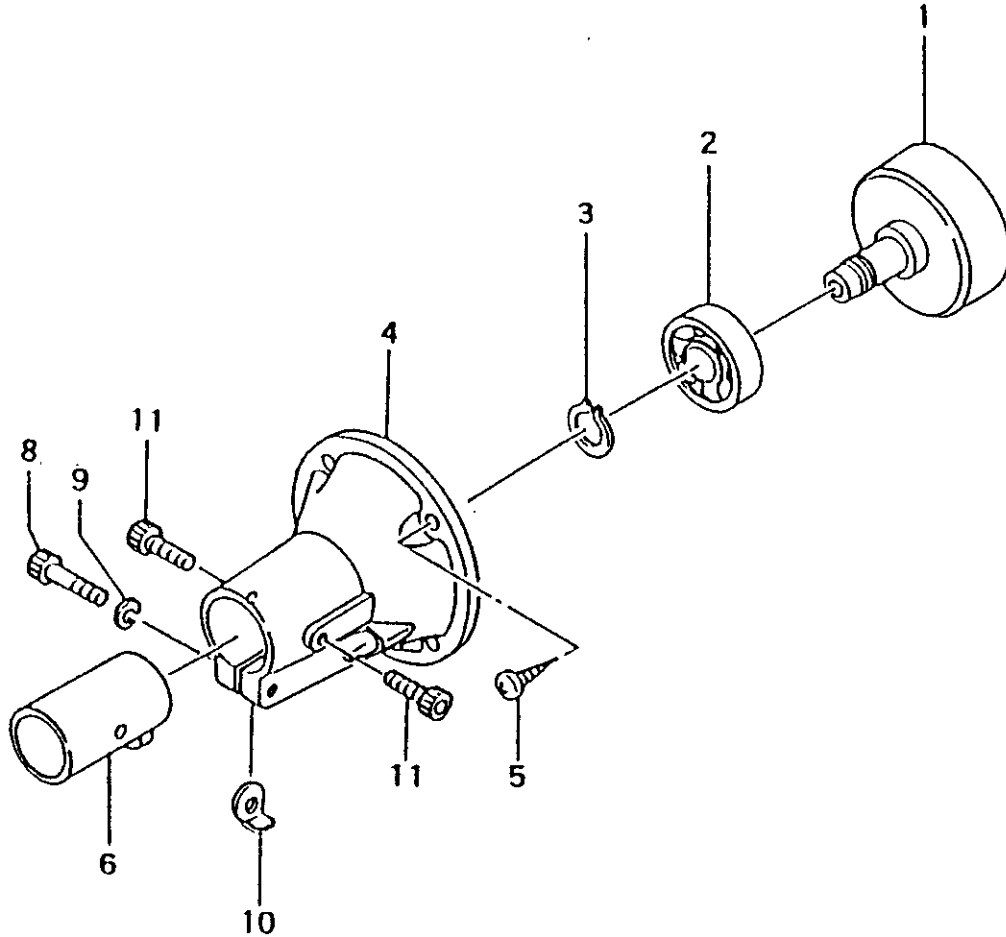

FIGURE 5

TBC-4500 PARTS LISTING

REF.	PART NO.	PART DESCRIPTION	Q	C	S	SERIAL NO.	REMARKS
1	289-0631Q-800	DRUM,CLUTCH	1		D	~L226930	
1	289-06460-80	DRUM,CLUTCH	1		D	L226931~	
2	999-61620-101	BEARING,BALL #6201ZZ	1		C		
3	993-50012-002	RING,STOP,C-12 EX	1		A		
4	331-00025-21	CASE,CLUTCH	1		C		
5	990-73050-184	SCREW,TAPPING,5X18	4		D		
6	599-0636J-21	CUSHION,ANTI-VIBE	1		D		
8	990-51050-253	BOLT,HEX,5X25	1		B		
9	992-10050-062	WASHER,S,5	1		D		
10	249-0630G-201	SPACER	1		D		
11	990-51050-153	BOLT,HEX.HOLE,5X15	2		C		

FIG.6 HANDLE

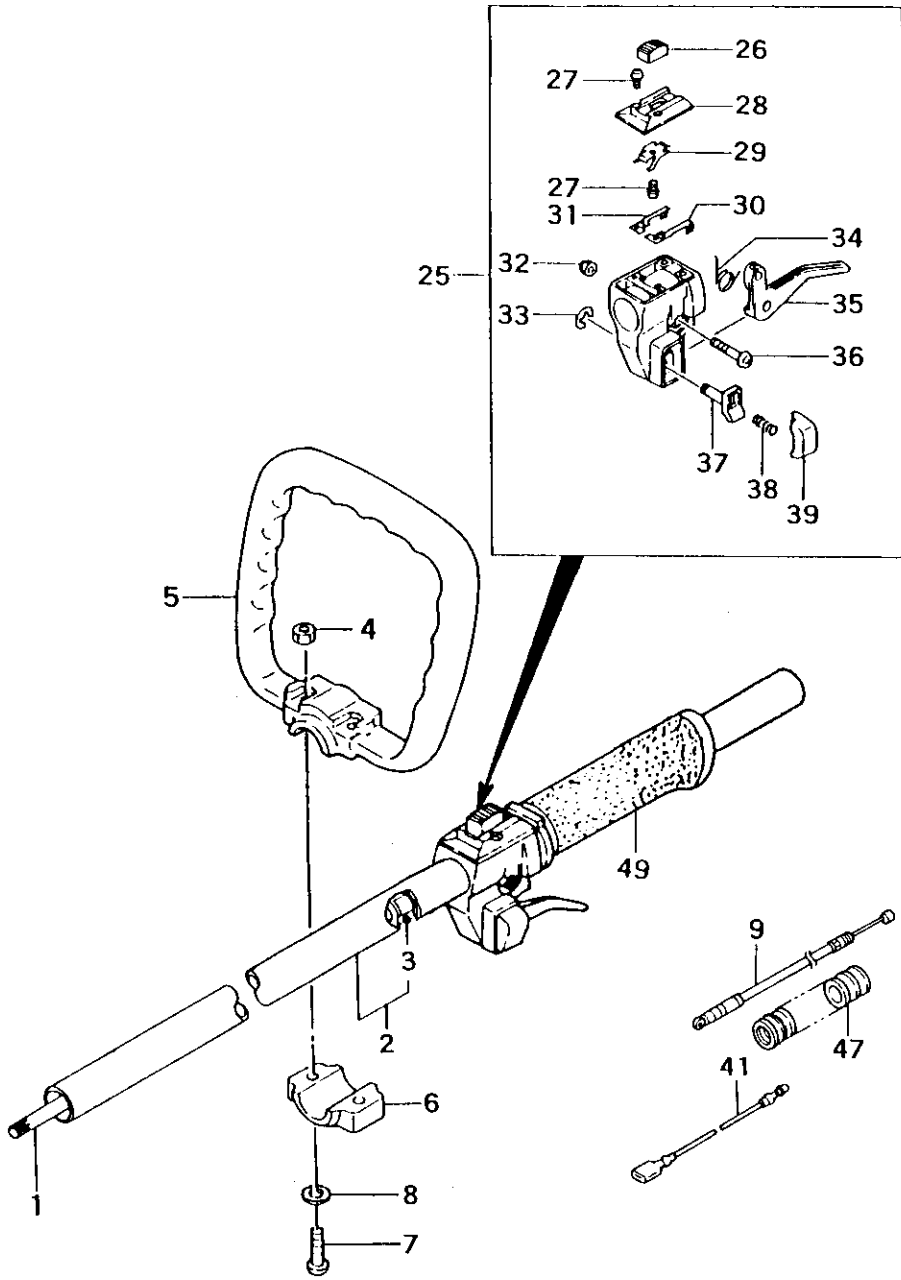

FIGURE 6

TBC-4500 PARTS LISTING

REF.	PART NO.	PART DESCRIPTION	Q	C	S	SERIAL NO.	REMARKS
1	343-37617-200	SHAFT,DRIVE 1491mm	1		C	~L226930	
1	343-37618-20	SHAFT,DRIVE 1483mm	1		D	L226931~	
2	341-37616-81	PIPE,DRIVE SHAFT	1		D		
3	347-37601-900	BUSHING,ASS'Y	5		C		
4	991-01060-011	NUT,6	2		A		
5	500-33316-20	HANDLE	1		D		
6	506-33316-200	BRACKET,HANDLE A	1		D		
7	990-23060-401	BOLT,P,6X40	2		D		
8	992-01060-011	WASHER,6	2		A		
9	885-00025-800	WIRE,THROTTLE	1		C		
25	870-37300-900	LEVER, THROTTLE ASS'Y	1		A		
26	162-37101-200	SWITCH,STOP	1		C		
27	993-42030-081	SCREW, TAPPING, 3X8	3		D		
28	259-37101-200	BASE,STOP SWITCH	1		C		
29	262-37101-200	SPRING,STOP SWITCH	1		D		
30	177-37101-200	TERMINAL,EARTH B	1		C		
31	176-37101-200	TERMINAL,EARTH A	1		D		
32	991-86050-000	NUT,LOCK,5	1		D		
33	993-55060-001	RING,STOP,6	1		D		
34	832-37101-200	SPRING,RETURN	1		C		
35	880-37101-200	ARM,THROTTLE	1		B		
36	994-31050-251	SCREW,S.,5X25	1		C		
37	853-37101-200	SHAFT,LOCK BUTTON	1		D		
38	958-37101-200	SPRING,LOCK,BUTTON	1		D		
39	956-37101-200	BUTTON,LOCK	1		D		
41	178-37300-801	CORD,STOP	2		C		
47	164-10014-010	TUBE,PROTECTION	1		D		
49	504-37300-200	GRIP,SHAFT	1		D		

* Indicates the part is included in a kit or assembly and is not available individually. Q=Quan. used C=Interchangeability S=Stocking code: A=Fast moving B=Med. fast C=Med. move D=Slow move E=N.L.A. F=Superceded or replaced by a new part

FIG.7 GEAR CASE

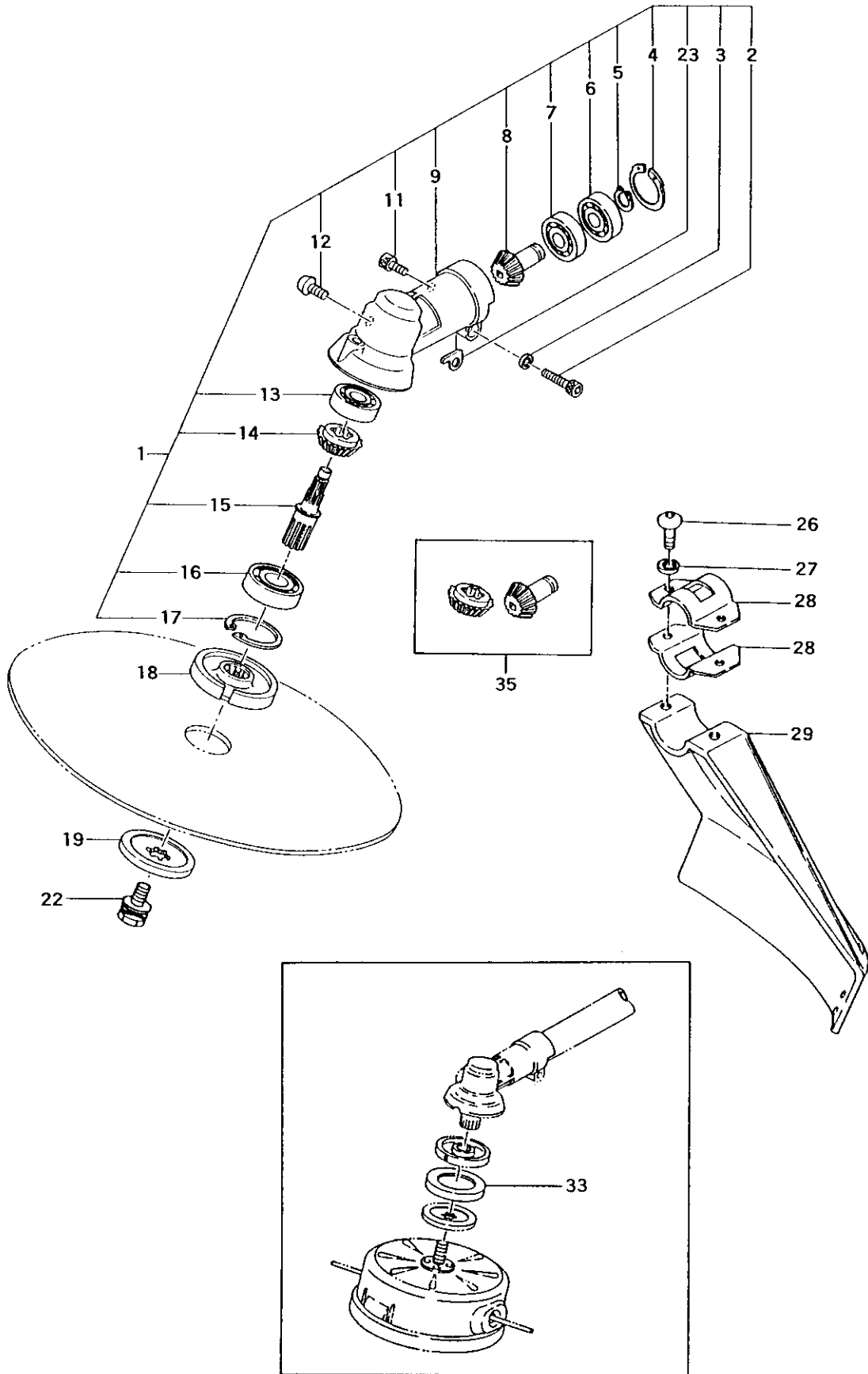

FIGURE 7

TBC-4500 PARTS LISTING

REF.	PART NO.	PART DESCRIPTION	Q	C	S	SERIAL NO.	REMARKS
1	300-37417-91	CASE,GEAR ASS'Y	1		D		
2	990-51050-253	BOLT,HEX,5X25	1		B		
3	992-10050-062	WASHER,S,5	1		D		
4	993-53022-002	RING,STOP,R22 IN	1		C		
5	993-50010-002	RING,STOP,C-10 EX	1		C		
6	999-61690-001	BEARING,BALL,#6900ZZ	1		B		
7	999-61690-000	BEARING,BALL,#6900	1		B		
9	300-37623-20	CASE,GEAR	1		D		
11	990-51050-103	BOLT,HEX.HOLE,5X10	1		C		
12	990-15080-100	SCREW,8X10	1		D		
13	999-61626-000	BEARING,BALL,#626	1		B		
15	304-37307-200	SHAFT,GEAR	1		C		
16	999-61600-104	BEARING,BALL,#6001DD	1		B		
17	993-51028-002	RING,STOP,IN,C-28	1		C		
18	310-37623-202	HOLDER,CUTTER	1		B		
19	311-37300-20	CAP,CUTTER HOLDER	1		A		
22	312-33386-20	BOLT, FIXING, L.H.	1		C		
23	324-37350-20	WASHER,GEAR CASE	1		D		
26	990-23060-161	BOLT,6X16 PLUS	2		C		
27	992-10060-012	WASHER,S,6	2		A		
28	442-37417-200	BRACKET,SAFETY GUARD	2		C		
29	441-33905-800	GUARD,SAFETY	1		A		
33	307-37307-200	PROTECTOR,WINDING	1		D		
35	301-37300-01	SET,GEAR/PINION	1		A		

* Indicates the part is included in a kit or assembly and is not available individually. Q=Quan. used C=Interchangeability S=Stocking code: A-Fast moving B=Med. fast C=Med. move D=Slow move E=N.L.A. F=Superseded or replaced by a new part

FIG.8 TOOLS & NYLON HEAD

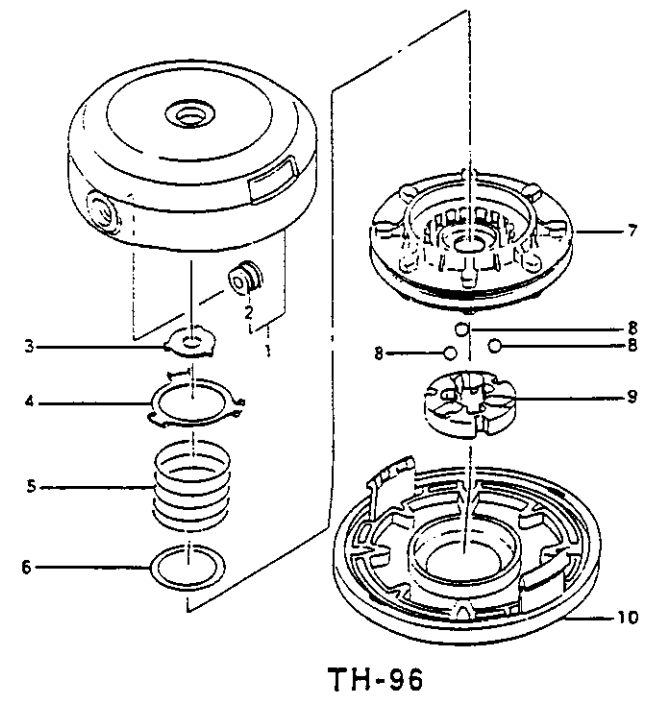
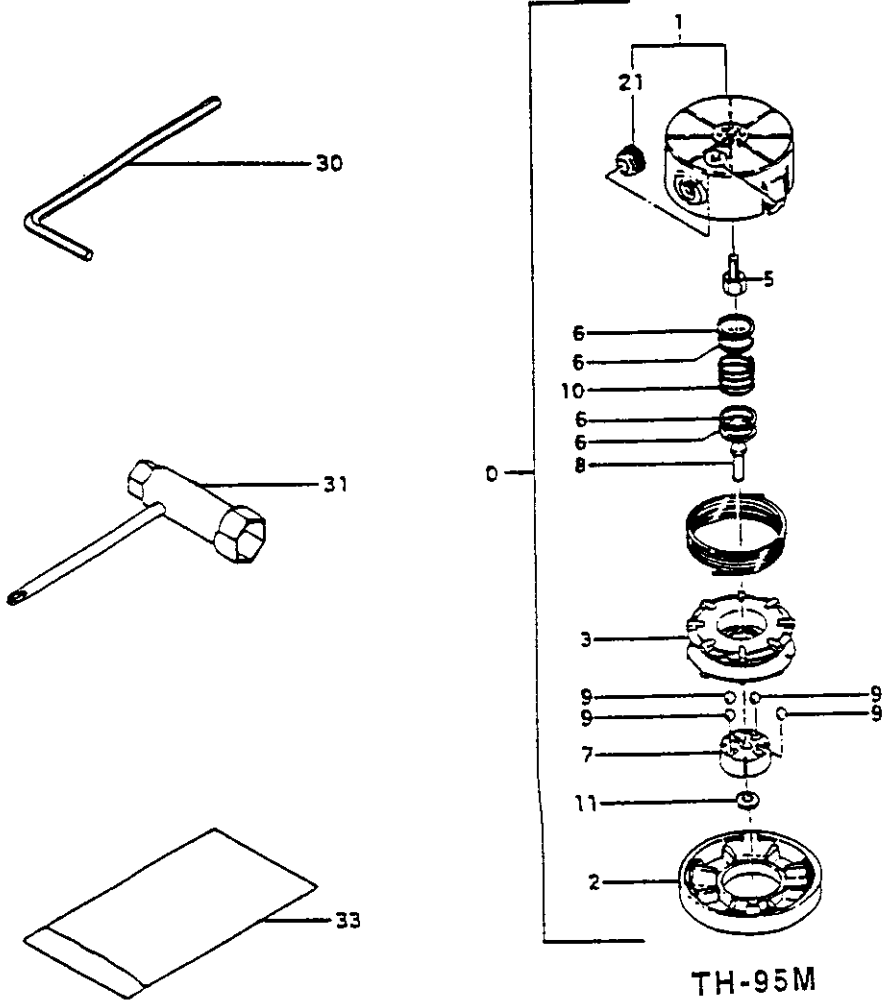

FIGURE 8

TBC-4500 PARTS LISTING

REF.	PART NO.	PART DESCRIPTION	Q	C	S	SERIAL NO.	REMARKS
0	783-33910-91	HEAD,1R486,AUTO,(M)	1		A	~Q203631	TH-95M
1	786-33004-900	BODY,CUTTING,ASS'Y	1		A		
2	789-33004-21	CAP,BODY	1		A		
3	787-33004-202	REEL,(R S M X)	1		A		
5	314-33670-20	BOLT,8X1.25 LH GOLD	1		A		
6	792-33004-200	WASHER,REEL	4		A		
7	790-33004-200	SLIDER,REEL	1		A		
8	791-33004-200	HOOK,REEL SLIDER	1		A		
9	673-35600-20	BALL,STEEL	4		B		
10	793-33910-20	SPRING,REEL	1		A		
11	358-02103-200	WASHER,CLUTCH A	1		A		
21	788-33071-20	EYELET	2		A		
30	813-20000-200	WRENCH,HEX,4	1		D		
31	829-20000-80	SPANNER,COMBI,13X19	1		C	~M218333	
31	826-20000-80	SPANNER,COMBI,17X19	1		C	M218334~	
33	948-39907-200	BAG,TOOL	4		D		

REF.	PART NO.	PART DESCRIPTION	Q	C	S	SERIAL NO.	REMARKS
0	783-33810-90	HEAD,AUTO,(TH-96)	1		B	Q203632~	TH-96 NOTE: This head can be fitted on any TBC-4500
1	786-33810-90	BODY,CUTTING	1		B		
2	788-33071-20	EYELET	2		A		
3	760-33810-20	WASHER,MOUNTING	1		A		
4	785-33810-20	BASE,ADJUSTMENT	1		B		
5	793-33810-21	SPRING, REEL, BLK.	1		A		
6	792-33810-20	WASHER,ADJUSTMENT	1		A		
7	787-33810-20	REEL	1		B		
8	673-35600-20	BALL,STEEL	3		B		
9	790-33810-20	SLIDER,REEL	1		B		
10	789-33810-20	CAP,BODY	1		B		

* Indicates the part is included in a kit or assembly and is not available individually. Q=Quan. used C=Interchangeability S=Stocking code: A=Fast moving B=Med. fast C=Med. move D=Slow move E=N.L.A. F=Superseded or replaced by a new part

FIG.9 MARKS

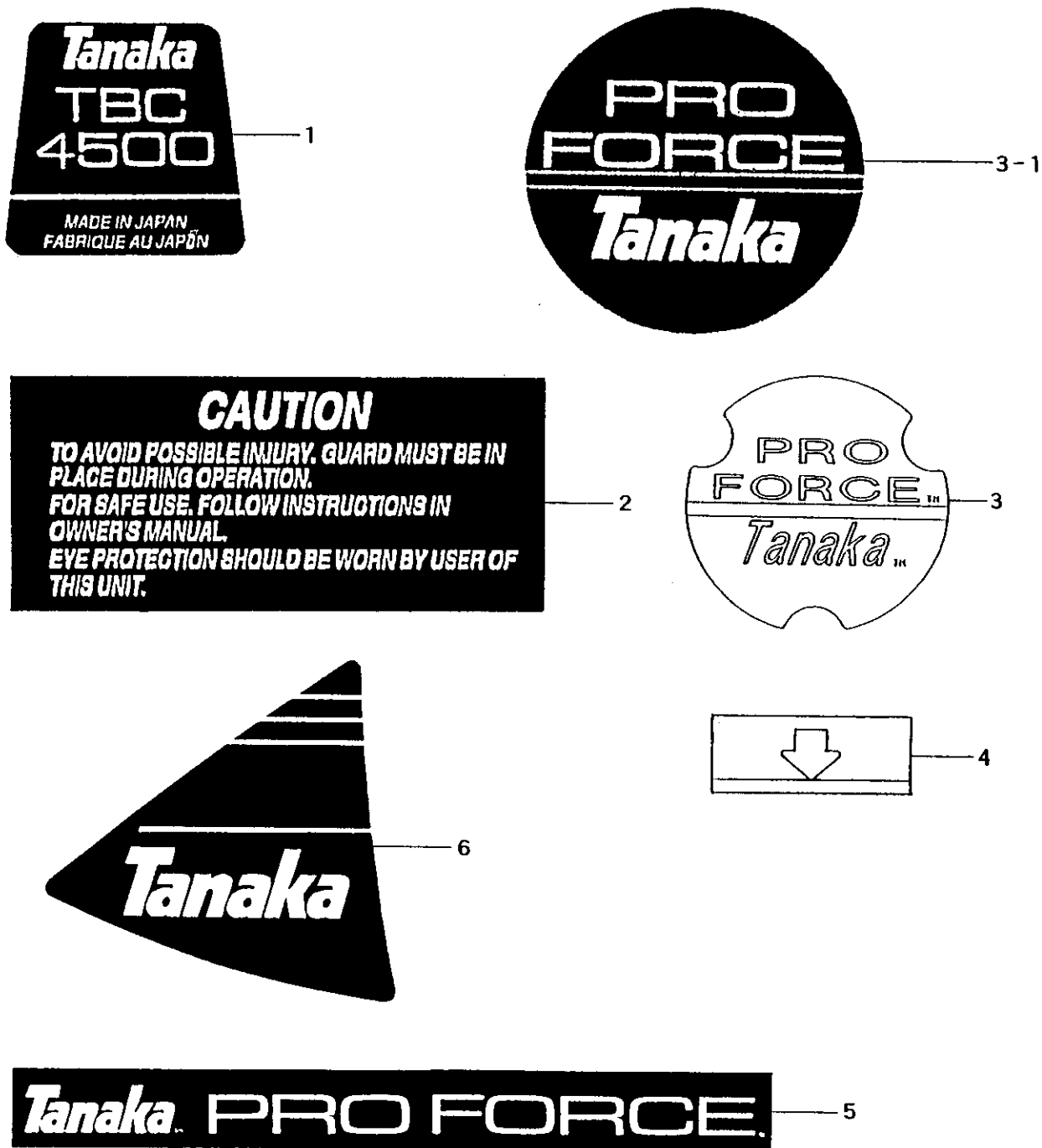

FIGURE 9

TBC-4500 PARTS LISTING

REF.	PART NO.	PART DESCRIPTION	Q	C	S	SERIAL NO.	REMARKS
1	906-37417-200	DECAL	1		D		
2	919-37701-200	DECAL	1		D		
3-1	950-37503-200	DECAL,PRO-FORCE A	1		D		
3	950-37724-20	DECAL,PRO-FORCE	1		D	~N214210	
4	923-37400-200	DECAL,LEVEL	1		D	N214211~	
5	951-31310-200	DECAL,PRO-FORCE B	1		D		
6	933-37301-200	DECAL,SYMBOL	1		D		