

MODEL: SS-1848SL

Key#	Part#	Description#	Key#	Part#	Description#
1	1015482	Screw	31	501638	O-Ring
3	1015484	Screw	32	501639	Cylinder
4	1015485	Washer	33	501640	Driver Blade Ass'y
5	1015486	Exhaust Deflector	34	501641	O-Ring
6	1015487	Silencer	35	501642	Gasket
7	501619	Head	36	1015527	O-Ring
8	1015489	Exhaust Gasket	37	1015528	Inlet Cap
9	1015340	Spring	38	501643	O-Ring
10	1015305	O-Ring	39	1015319	E-Ring
11	501621	O-Ring	40	1015519	Safety Guide
12	501622	O-Ring	41	1015521	Pin
13	501623	Valve Ass'y	42	1015520	Trigger
14	501624	Ring	44	1015303	O-Ring
15	501625	O-Ring	45	1015509	Trigger Valve Housing
16	501626	Head Gasket	46	1015510	O-Ring
17	1015506	Screw	47	1015511	O-Ring
18	501627	Screw	48	1015512	Valve Piston
19	501628	Noseplate	< 49	501418	O-Ring
20	501629	Nose	50	1015514	O-Ring
21	1015507	Spring	< 51	502718	Spring
22	501630	Safety	52	501648	O-Ring
23	502709	Pusher	53	1015516	Trigger Valve
24	501992	Magazine	54	1015517	Bush
25	501633	Screw	55	1015518	E-Ring
26	501634	Support	56	501650	Trigger Valve Ass'y
27	501635	Screw	57	501651	Latch
28	501888	Body	58	1015338	Spring
29	501637	Bumper	59	501652	Pin
30	1015492	O-Ring	60	502703	Slider

* = New Part
< = Part Change

SAFETY: A pair of safety glasses that meets ANSI Z87.1 requirements must always be worn when using this tool. The use of proper eye protection has been shown to significantly reduce eye injuries. Complete safety training is available from your DUO-FAST representatives. It includes a wide range of safety materials to help keep safety awareness high throughout the work area.



SEGURIDAD: Un par de gafas de seguridad que cumplen con los requerimientos ANSI Z87.1 deber ser siempre usados con el uso de esta herramienta. El uso de protección ocular adecuada ha mostrado que reduce significativamente las lesiones oculares. Una capacitación completa sobre seguridad está disponible a través de sus representantes de DUO-FAST. La misma incluye una amplia gama de material sobre seguridad para ayudarlo a mantener un alto nivel de conciencia sobre la seguridad en toda el área de trabajo.



WARRANTY: Before buying or using any DUO-FAST tool, read the limited warranty that applies. For warranty details, see the full-line catalog or the warranty information in the tool carton.

GARANTÍA: Antes de comprar o utilizar cualquier herramienta DUO-FAST, lea la garantía limitada que se aplica. Para obtener detalles de la garantía consulte el catálogo de toda la línea o la información sobre la garantía en la caja de la herramienta.

SureShot 1848SL

Heavy Duty Stapler

Grapadora Neumatica Para Trabajo Pesado

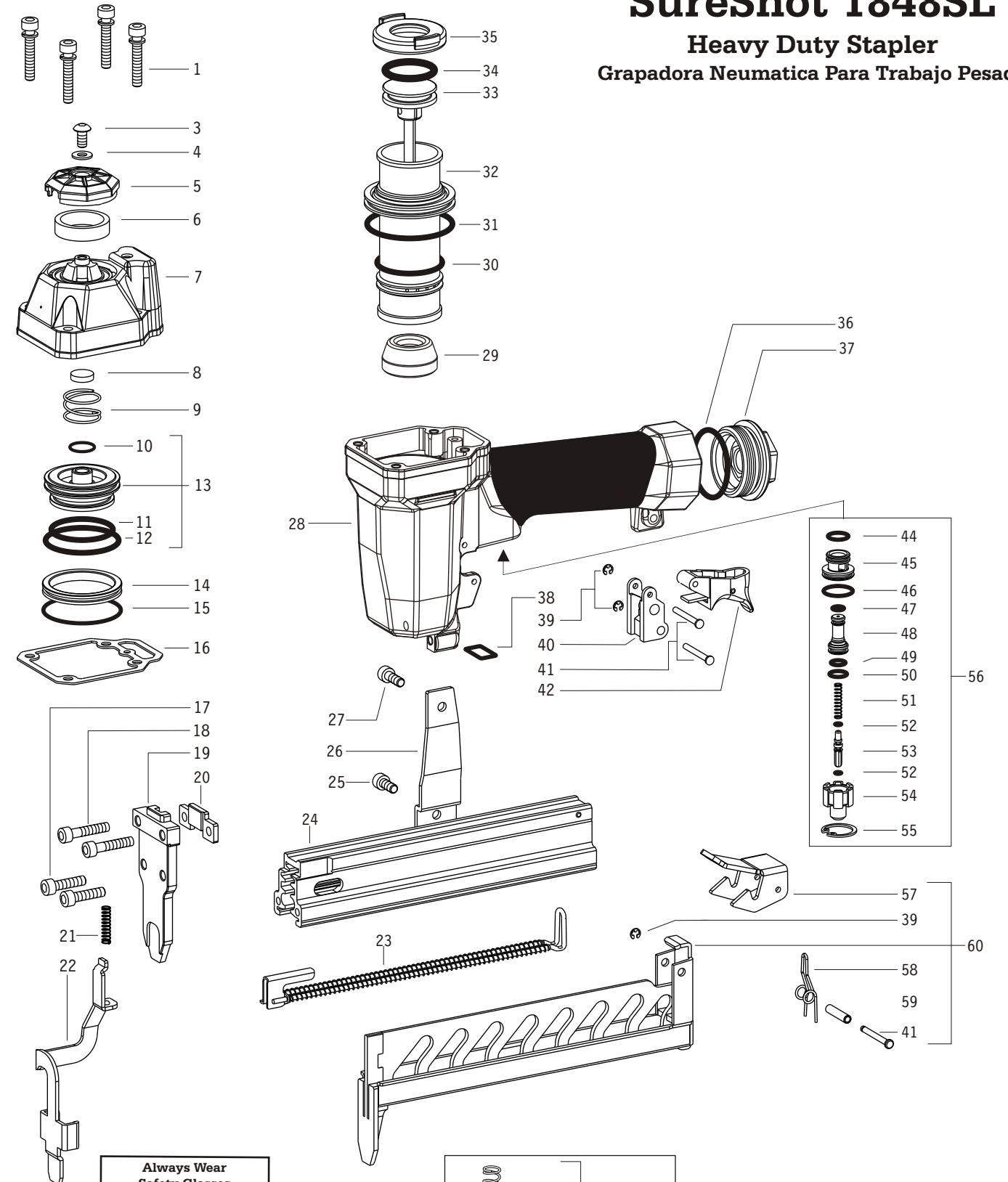

Always Wear Safety Glasses

When Using Power Tools
402510

Conversion Kit
Single sequential actuation
#219272

SURESHOT
1848SL