



# SPARE PARTS LIST

EARLY ENTRY SAWS

SOFF CUT 5000, 2016-11

**A** SOFF CUT X5000  
ENGINE ASSEMBLY

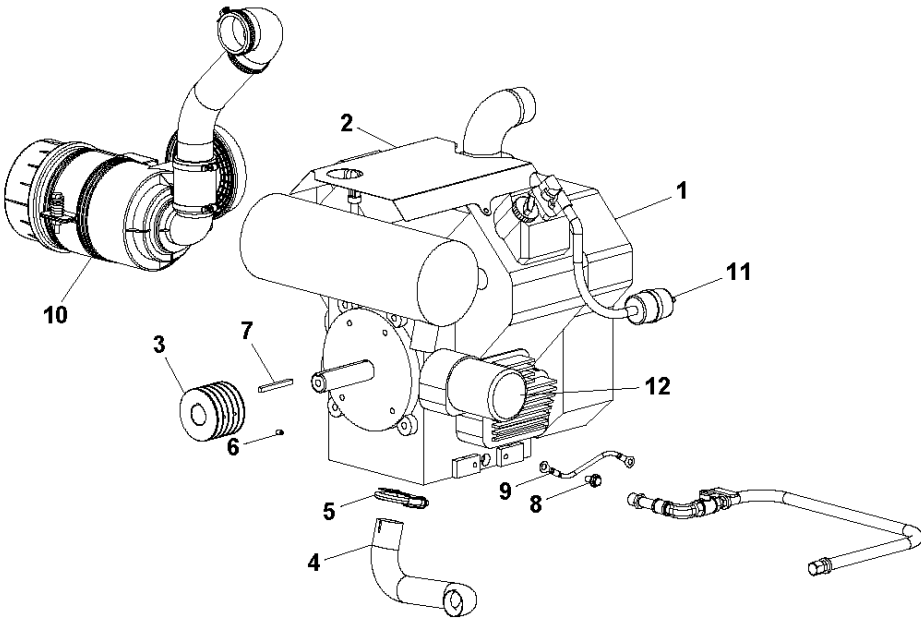

## ENGINE

SOFF CUT 5000, 2016-11

Ref	Part No	Description	Remark	QTY KIT
1	505 66 65-02	ENGINE		1
2	510 32 37-01	HEAT SHROUD		1
3	510 32 60-01	PULLEY		1
4	510 32 59-01	EXHAUST		1
5	510 32 71-01	CLAMP		1
6	542 02 05-41	SHSS,.25-20 X.375 CUP HK/CONCR		4
7	542 19 90-45	KEY		1
8	505 79 56-01	M8 X 16MM FLANGE BOLT		1
9	575 44 66-05	KIT		1
10	P/Needed	TBD		
11	505 79 82-01	FUEL FILTER		1
12	505 79 74-01	OIL FILTER		1

**B** SOFF CUT X5000  
KIT, MOTOR MOUNT

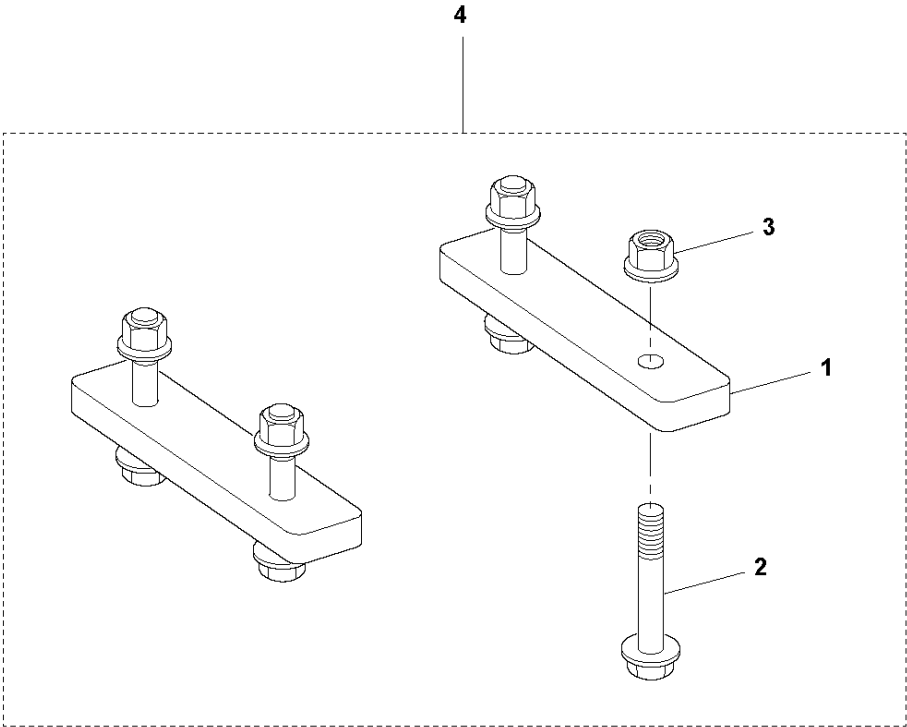

Ref	Part No	Description	Remark	QTY	KIT
1	501 08 06-01	PLATE		2	4
2	581 24 33-01	SCREW EHHFM		4	4
3	576 64 57-05	NUT FLANGE		4	4
4	582 23 87-01	MOTOR KIT		1	

**C** SOFF CUT X5000  
INTAKE SYSTEM ASSEMBLY

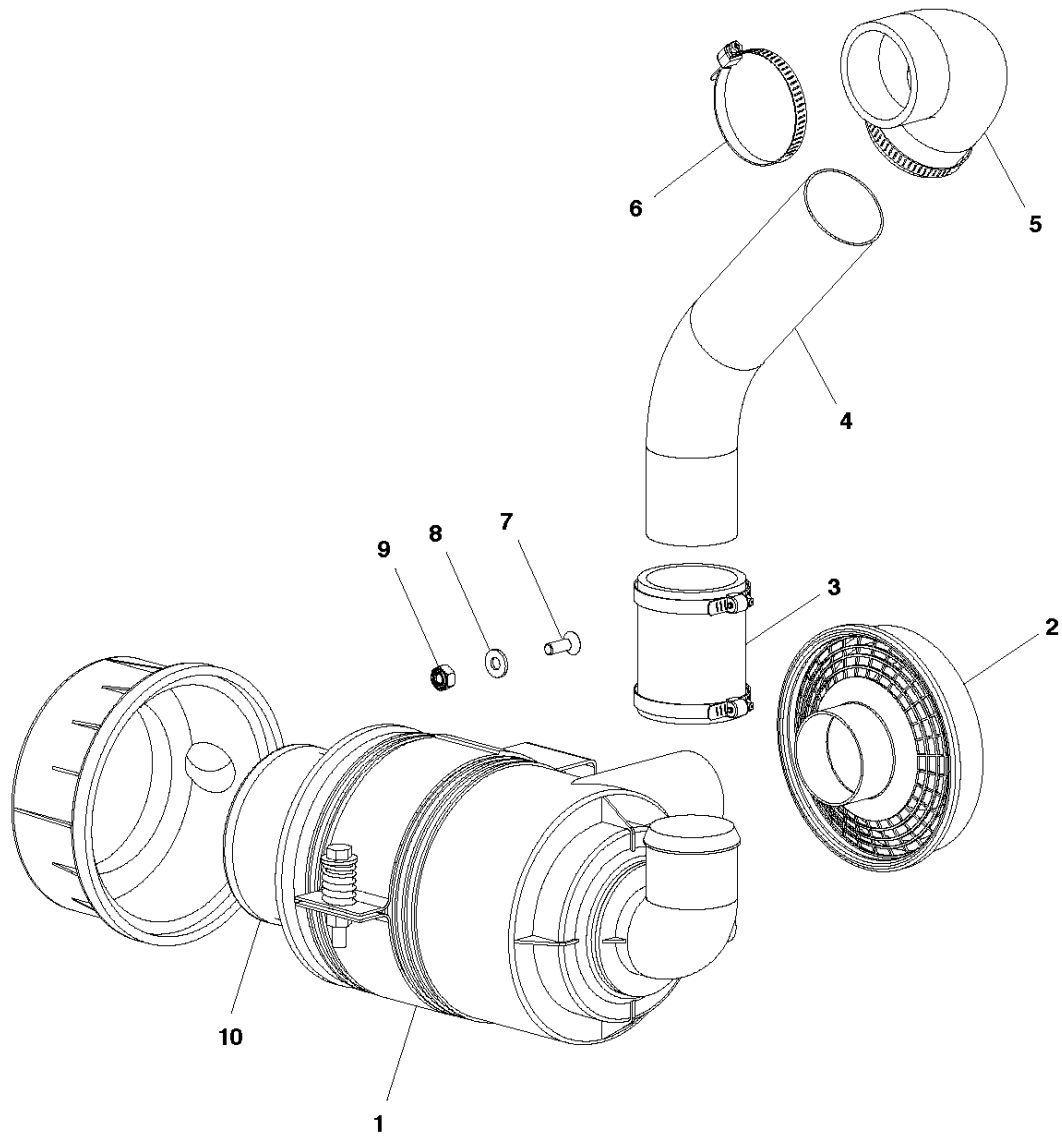

## INTAKE SYSTEM

SOFF CUT 5000, 2016-11

Ref	Part No	Description	Remark	QTY KIT
1	505 83 61-01	AIR CLEANER		1
2	505 83 63-01	HOOD		1
3	575 65 42-03	HOSE		1
4	510 32 39-01	INTAKE ELBOW		1
5	505 74 50-02	ELBOW		1
6	505 77 60-01	1 9/16--2 1/2 WORM GEAR CLAMP		4
7	505 62 86-01	FHS 1/4-20-3/4 S.S.		2
8	505 63 20-01	WASHER		2
9	539 97 69-78	NUT		2
10	505 48 23-06	FILTER		1

**D** SOFF CUT X5000  
KIT, OIL DRAIN

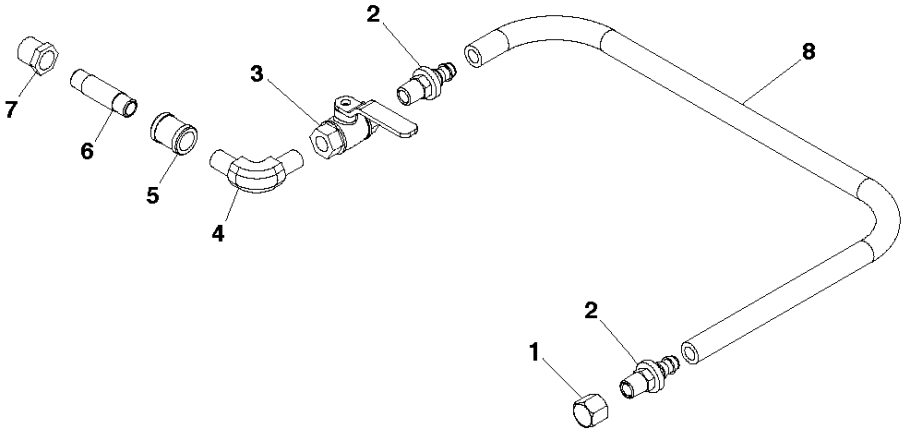



## OIL DRAIN

SOFF CUT 5000, 2016-11

Ref	Part No	Description	Remark	QTY KIT
1	505 77 66-01	DUST CAP FOR OIL DRAIN-RP85123		1
2	505 73 86-01	GATES 6LOC-4RMP PUSH ON FITTIN		2
3	505 73 89-01	LHA BALL VALVE BV-04N		1
4	505 73 87-01	HCI ADAPTER MP-MP90-4-4		1
5	505 79 66-01	1/4 BRASS COUPLING		1
6	505 79 65-01	1/4" X 2" BRASS NIPPLE		1
7	505 79 64-01	HEX BUSHING		1
8	505 73 85-01	GATES 6 LOLA+ 3/8 I.D. HOSE		1

**E** SOFF CUT X5000  
BLADE IDLER PULLEY

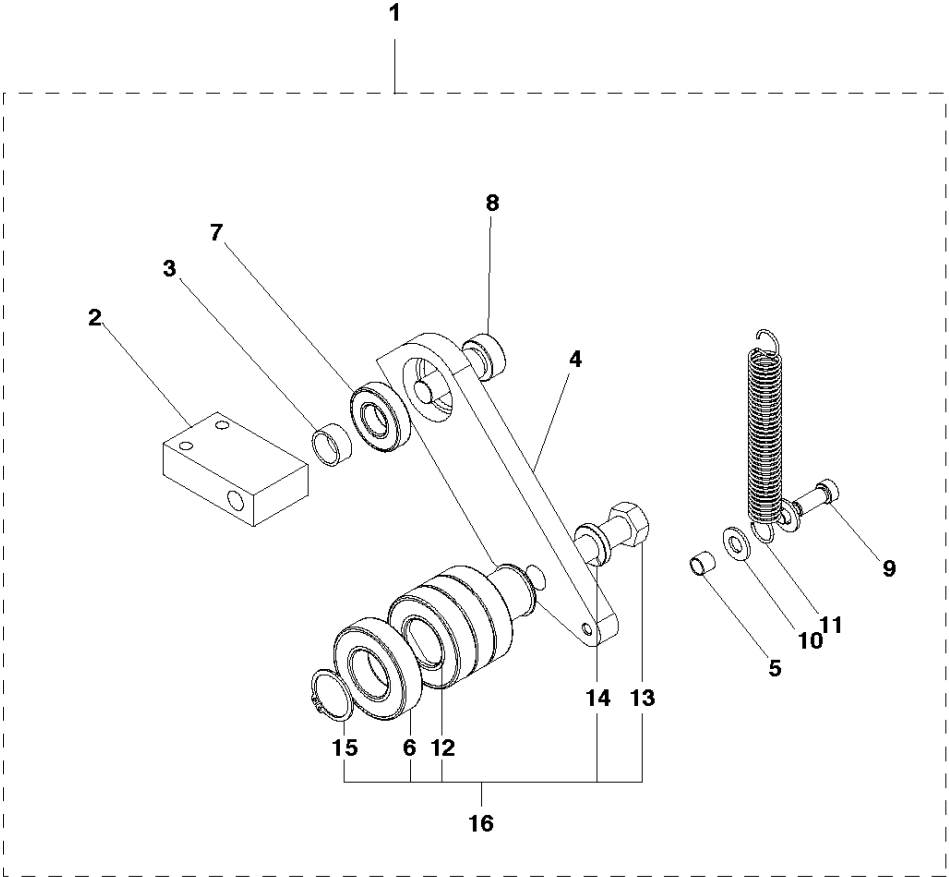

## BLADE IDLER PULLEY

SOFF CUT 5000, 2016-11

Ref	Part No	Description	Remark	QTY	KIT
1	579876601	TBD		1	
2	505 66 45-01	BLOCK. IDLER MOUNT		1	1
3	505 71 46-02	SPACER		1	1
4	505 66 39-01	IDLER PULLEY ARM		1	1
5	505 71 79-01	BUSHING.G.A.(.315 SPACER)		1	1
6	505 73 63-01	WHEEL		4	1, 16
7	505 73 60-01	PULLEY		1	1
8	505 72 62-01	SHSB 5/8 X 3/4 BLK STL		1	1
9	505 72 64-01	SHSB 5/16 X 3/4 BLK STL		1	1
10	539 99 01-88	WASHER		2	1
11	505 79 69-01	SPRING		1	1
12	505 66 50-01	SHAFT.BLADE BELT TENSIONER		1	1, 16
13	505 82 11-01	HEX BOLT 1/2 - 13 X 1 1/2 GR 8		1	1, 16
14	505 73 11-01	LK WASH 1/2 SPLIT SS		1	1, 16
15	542 20 62-05	SNAP RING		2	1,16
16	505 48 45-02	PULLEY		1	1

**F** SOFF CUT X5000  
PUMP IDLER PULLEY

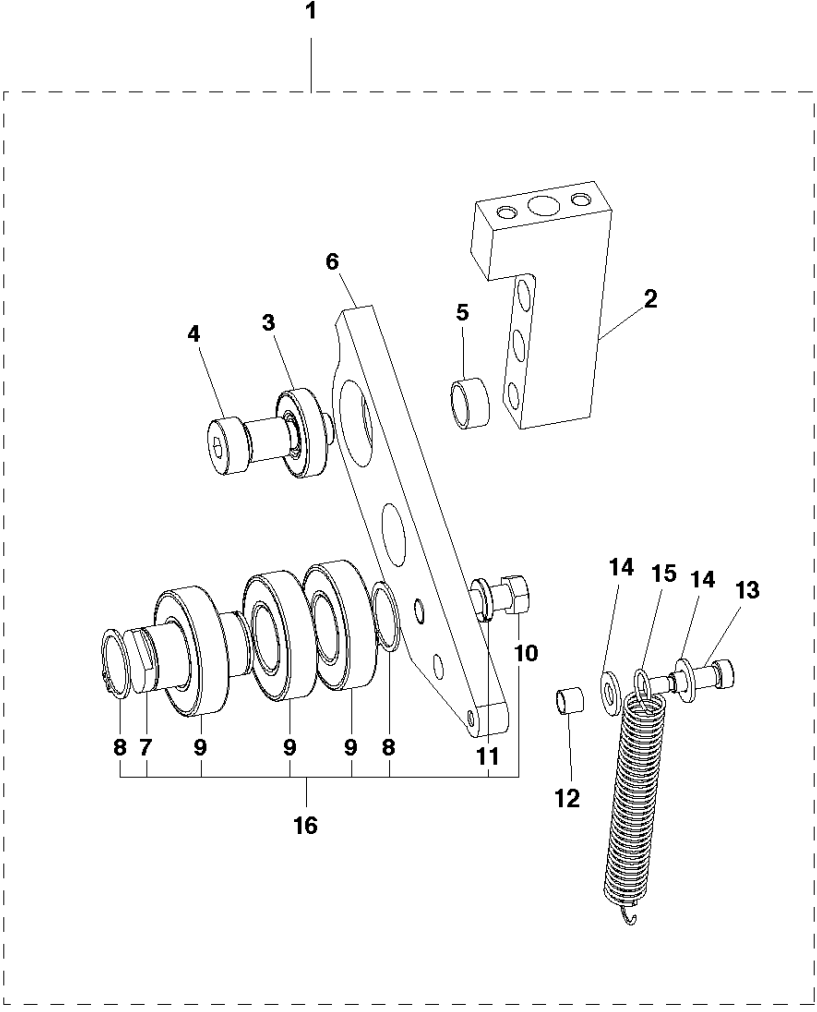

## PUMP IDLER PULLEY

SOFF CUT 5000, 2016-11

Ref	Part No	Description	Remark	QTY KIT
1	510 27 18-01	ASSEMBLY		1
2	505 71 44-01	MTG BLOCK PUMP IDLER PULLEY		1
3	505 73 60-01	PULLEY		1
4	505 72 62-01	SHSB 5/8 X 3/4 BLK STL		1
5	505 71 46-02	SPACER		1
6	505 70 69-01	PUMP ARM IDLER PULLEY		1
7	505 70 68-01	BLADE		1
8	542 20 62-05	SNAP RING		2
9	505 73 63-01	WHEEL		3
10	505 79 58-01	HEX HD 3/8-16X1 1/2 GR 8		1
11	505 73 10-01	LK WASH 3/8 SPLIT SS		1
12	505 71 79-01	BUSHING.G.A.(.315 SPACER)		1
13	505 72 64-01	SHSB 5/16 X 3/4 BLK STL		1
14	539 99 01-88	WASHER		2
15	505 77 46-01	PUMP		1
16	505 48 34-01	PULLEY		1

**G** SOFF CUT X5000  
BLADE SHAFT ASSEMBLY

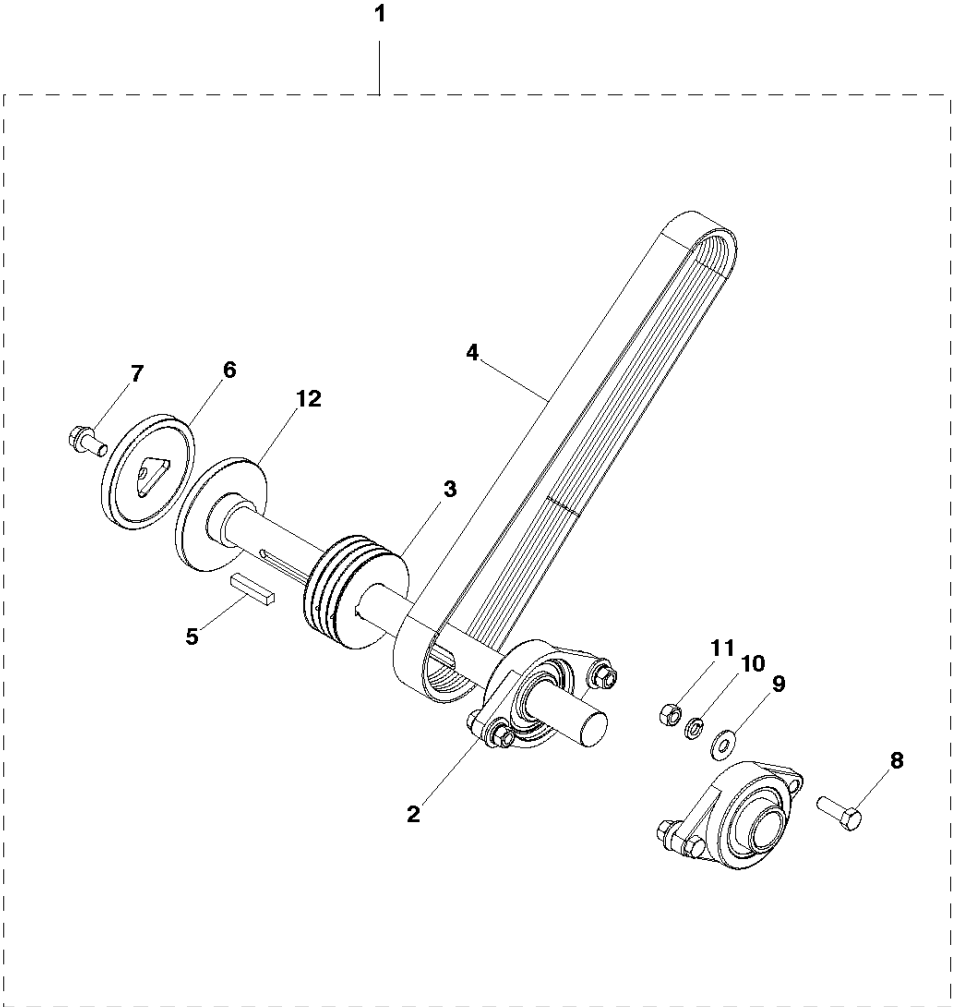

## BLADE SHAFT

SOFF CUT 5000, 2016-11

Ref	Part No	Description	Remark	QTY KIT	
1	510 27 22-01	ASSEMBLY		1	
2	505 77 41-01	BLADE SHAFT		2	1
3	585 00 48-01	SHEAVE	Machines with S/N before 001317909001 needs to buy both pos 3 and 4	1	1
4	542 16 66-29	V-BELT	Machines with S/N before 001317909001 needs to buy both pos 3 and 4	1	1
5	510 32 69-01	KEY		1	1
6	505 49 15-06	WASHER		1	1
7	505 48 37-01	BOLT		1	1
8	505 82 11-01	HEX BOLT 1/2 - 13 X 1 1/2 GR 8		4	1
9	505 73 14-01	FLAT WASH 1/2 X 1 1/4 O.D. S.S		4	1
10	505 73 11-01	LK WASH 1/2 SPLIT SS		4	1
11	505 73 33-01	1/2-13 HEX NUT GOLD GR.8		4	1
12	505 57 32-05	SHAFT		1	1

**H** SOFF CUT X5000  
FRONT WHEEL CARRIAGE

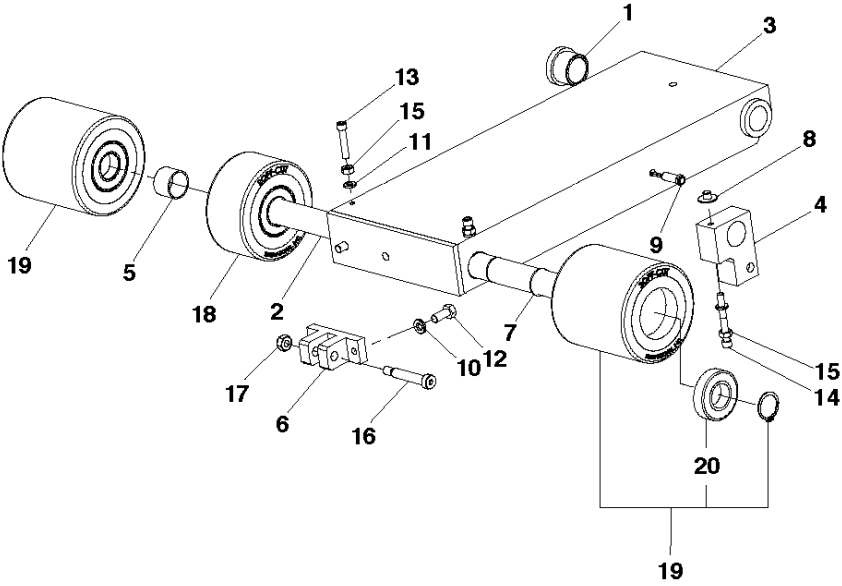



## FRONT WHEEL CARRIAGE

SOFF CUT 5000, 2016-11

Ref	Part No	Description	Remark	QTY KIT
1	505 70 51-01	BUSHING		2
2	505 76 40-01	AXLE		1
3	505 66 01-01	FRONT WHEEL CARRIAGE. X5000		1
4	505 66 03-01	BLOCK. DRIVE RELEASE		1
5	505 76 41-01	FRONT WHEEL SHAFT SPACER 1 1/8		1
6	505 75 69-01	ACTUATOR		1
7	542 20 62-05	SNAP RING		1
8	505 62 53-01	S.S. BUTTON *****		1
9	505 75 43-01	PROX SWITCH FPM/LINEAR FT - CE		1
10	505 63 30-01	LK WASH 5/16 SPLIT SS		2
11	505 63 28-01	LK WASH 1/4 SPLIT SS		3
12	539 97 69-34	BOLT		2
13	505 62 80-01	SHC 1/4-20-1 1/4 S.S.		2
14	505 72 89-01	SHC 1/4-20-2 S.S.		1
15	505 63 19-01	JAM NUT 1/4-20 STAINLESS STEEL		3
16	505 77 15-01	SHSB 3/8 X 1 3/4		1
17	539 99 07-17	NUT		1
18	505 86 92-01	WHEEL ASSY		1
19	505 86 91-01	WHEEL ASSY		2



## PUMP

SOFF CUT 5000, 2016-11

Ref	Part No	Description	Remark	QTY KIT
1	505 58 69-01	BUSHING		2
2	505 65 82-01	FRAME		1
3	505 65 87-01	SHAFT. PUMP PIVOT		1
4	542 20 62-05	SNAP RING		2
5	505 76 47-01	DRIVE SHAFT		1
6	505 60 24-01	S1622 SPUR GEAR		1
7	505 62 86-01	FHS 1/4-20-3/4 S.S.		2
8	505 65 88-01	BUSHING		1
9	582382801	TBD		1
10	587 65 99-01	SPROCKET		1
11	505 73 98-01	PULLEY PUMP 1/3V 5.00 X 17 MM		1
12	505 76 48-01	SS WASHER FOR DRIVE SHAFT		2
13	5339990517	TBD		4
14	539 99 01-30	NUT		4
15	505 82 07-01	SHSB 3/8 X 1 1/4 BLACK		1
16	505 73 35-01	SNAP RING		2
17	539 30 08-70	NLA HCS 3/8-16 X 3-1/2 GR 5 ZN		4
18	505 73 11-01	LK WASH 1/2 SPLIT SS		4
19	523 32 77-01	NUT JAM 1/2-13		4
20	505 82 11-01	HEX BOLT 1/2 - 13 X 1 1/2 GR 8		4
21	505 65 85-01	ARM		1
22	505 72 23-01	SHC 1/4-20-1/2 S.S		2
23	505 63 28-01	LK WASH 1/4 SPLIT SS		7
24	505 77 27-01	1/4-20 X 1/4 SHCS SS		4
25	505 63 45-01	FLAT WSHR .750X.379 X.031 DEL		1
26	505 63 42-01	FLAT WSHR.750 X .375 X .031 SS		1
27	505 63 17-01	NYLOC NUT 5/16-18 .265"HT.		1
28	505 77 70-01	1624 SPUR GEAR(BOTH SAWS)/RIGH		1
29	505 65 86-01	PLATE. PUMP SUPPORT		1
30	505 65 84-01	ARM		1
31	505 68 94-01	PUMP/DRIVE SHAFT BEARING		2
32	505 73 10-01	LK WASH 3/8 SPLIT SS		8
33	505 72 40-01	FLAT WASH 3/8 AN 960 WASHERS U		4
34	505 62 78-01	SHC 1/4-20-3/4 S.S.		2
35	505 77 52-01	5460 SPRG FOR PUMP TENSIONER		3
36	505 77 45-01	SPRING ANCHORS		3
37	505 72 96-01	SHC 10-32 X 1/2 S.S. CBL MTS		2
38	505 63 31-01	LK WASH #10 SPLIT SS		2
39	510 31 81-01	KEY		1
40	539 99 01-88	WASHER		1
41	505 63 30-01	LK WASH 5/16 SPLIT SS		1
42	505 73 24-01	NUT		1
43	539 99 02-09	BOLT		1
44	542 02 05-41	SHSS,.25-20 X.375 CUP HK/CONCR		1
45	539 30 07-49	KEY		2
46	505 66 64-01	BRACKET		1
47	505 73 94-01	SPROCKET		1
48	587 70 66-01	KIT		1
49	505 73 96-01	CONNECTING LINK #35		1
50	505 75 43-01	PROX SWITCH FPM/LINEAR FT - CE		1
51	505 68 62-01	1/4 COUNTERSUNK EXT LOCKWASHER		2
52	505 63 19-01	JAM NUT 1/4-20 STAINLESS STEEL		3
53	539 97 69-79	NUT		1
54	505 63 42-01	FLAT WSHR.750 X .375 X .031 SS		1
55	542 02 05-41	SHSS,.25-20 X.375 CUP HK/CONCR		2
56	505 86 23-01	X5000 SPEED CONTROL KIT		1
57	505 48 40-03	BELT		1

**K** SOFF CUT X5000  
SPEED CONTROL CABLE

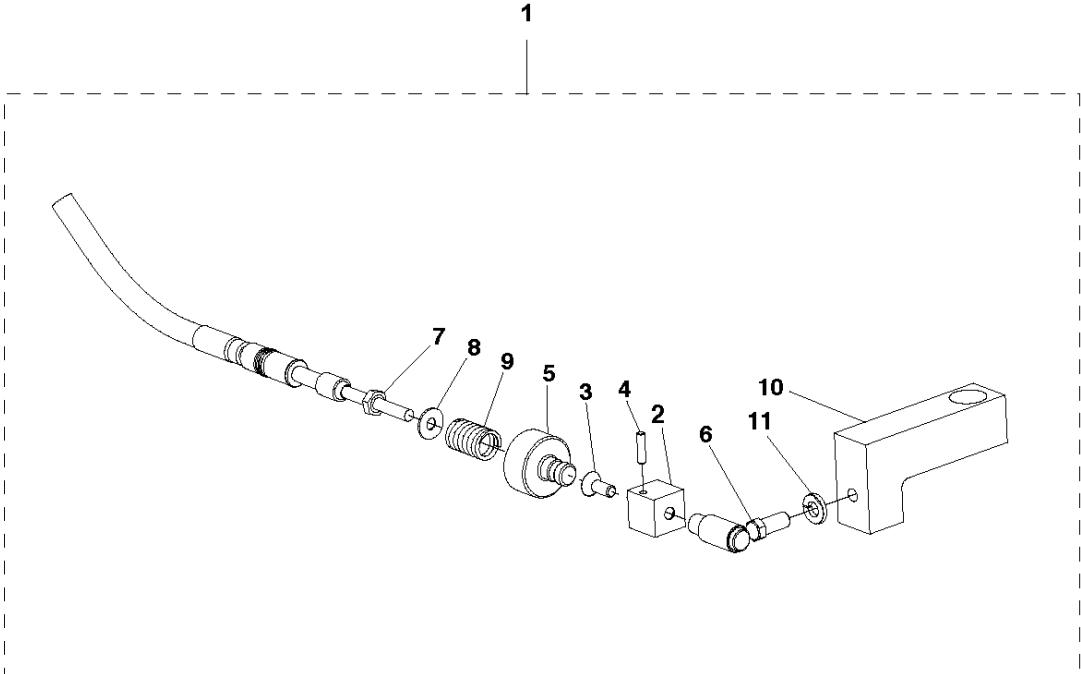

## SPEED CONTROL

SOFF CUT 5000, 2016-11

Ref	Part No	Description	Remark	QTY	KIT
1	505 86 23-01	X5000 SPEED CONTROL KIT		1	
2	505 65 89-01	CONTROL CABLE		1	1
3	505 72 99-01	FHS 10-32-1/2 S.S.		1	1
4	505 63 37-01	PRECISION DOW PIN STL 1/8 X 1/		1	1
5	505 65 90-01	FITTING		1	1
6	505 82 35-01	BALL JOINT		1	1
7	505 82 30-01	CONTROL CABLE		1	1
8	505 72 53-01	.500 OD X .190 ID X .030 THICK		1	1
9	505 77 51-01	#510 SPRG FOR STUD/SPD CTRL		1	1
10	505 71 49-01	PUMP CONTROL ARM GS1000 & G20		1	1
11	505 63 28-01	LK WASH 1/4 SPLIT SS		1	1

**L** SOFF CUT X5000  
CONTROL PANEL ASSEMBLY

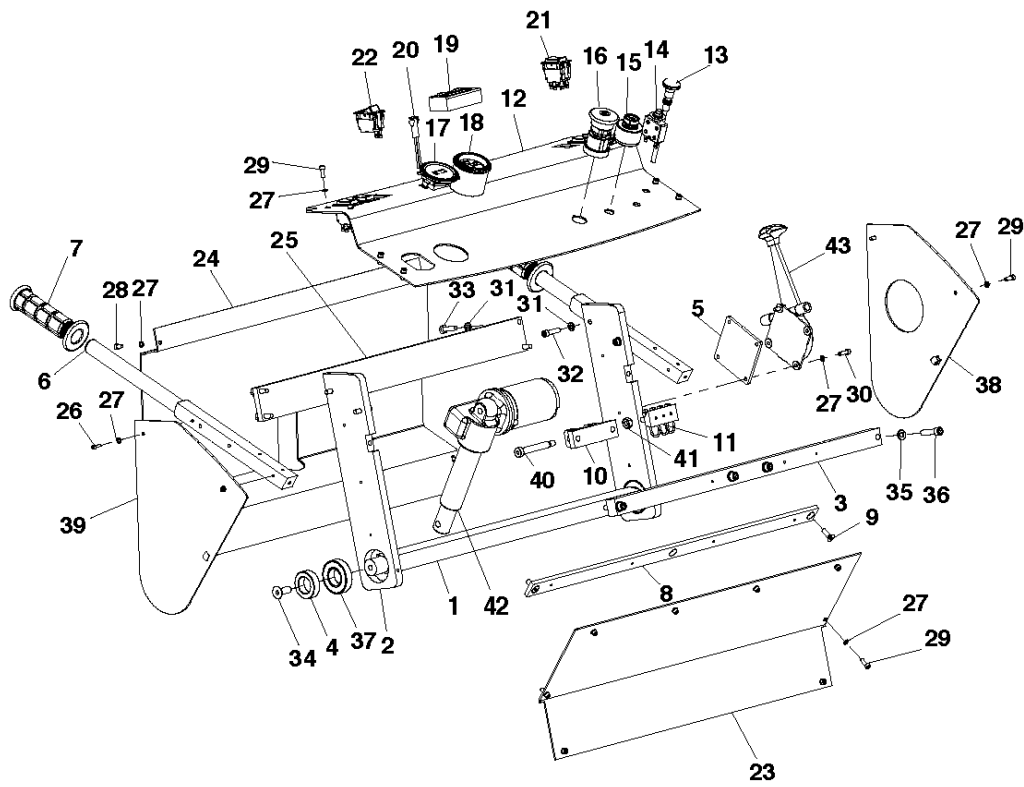

## CONTROL PANEL

SOFF CUT 5000, 2016-11

Ref	Part No	Description	Remark	QTY KIT
1	505 65 79-01	SHAFT. CONTROL PANEL PIVOT		1
2	505 65 72-01	ARM. CP PIVOT		2
3	505 65 71-01	ACTUATOR		1
4	505 65 80-01	SPACER		2
5	505 65 81-01	SPACER		1
6	505 65 78-01	SHAFT. CONTROL PANEL HANDLE		2
7	505 60 11-01	HANDLE GRIP		2
8	505 75 85-01	CROSS BAR (KEY DASH)		1
9	505 62 86-01	FHS 1/4-20-3/4 S.S.		2
10	505 75 70-01	ACTUATOR		1
11	505 75 27-01	TERMINAL BLOCK FOR G2000		1
12	505 65 73-01	PANEL. CONTROL GAGE		1
13	505 69 50-01	CHOKE		1
14	505 60 51-01	25 AMP. CIRCUIT BREAKER		1
15	505 79 76-01	KEY SWITCH		1
16	505 70 44-01	STOP SWITCH		1
17	505 75 02-02	TACHOMETER		1
18	505 70 43-01	METER		1
19	505 60 50-01	HOUR METER		1
20	505 84 60-01	G2/G1/GX3000 LED LIGHT		1
21	582 51 85-01	SWITCH		4
22	582518601	TBD		1
23	505 65 76-01	PANEL. CONTROL FRONT		1
24	505 65 77-01	PANEL. CONTROL REAR		1
25	505 66 47-01	CROSS BAR. CP. REAR		1
26	505 80 20-01	SHC 6-32 X 1/2 STAINLESS STEEL		2
27	505 63 31-01	LK WASH #10 SPLIT SS		26
28	505 62 77-01	SHC 10-32-3/8 S.S. NF		4
29	505 72 96-01	SHC 10-32 X 1/2 S.S. CBL MTS		18
30	505 72 97-01	SHC 10-32 X 5/8 S.S.		2
31	505 63 28-01	LK WASH 1/4 SPLIT SS		8
32	505 62 79-01	SHC 1/4-20-1 S.S.		4
33	505 72 73-01	HEX BOLT 1/4-20-1 STAINLESS ST		4
34	510 32 51-01	3/8-16 X 1 FHS S.S.		2
35	505 63 30-01	LK WASH 5/16 SPLIT SS		4
36	505 68 86-01	SHC 5/16-18 X 1 1/4 BLACK STEEL		4
37	505 73 63-01	WHEEL		2
38	505 65 75-01	PANEL. CONTROL LEFT SIDE		1
39	505 65 74-01	PANEL. CONTROL RIGHT SIDE		1
40	505 62 72-01	SHSH BOLT 3/8 X 2 1/4" (WHEELS		1
41	539 99 07-17	NUT		1
42	505 84 49-02	KIT		1
43	505 82 36-01	CONTROL LEVER		1

**M** SOFF CUT X5000  
BLADE BLOCK ASSEMBLY

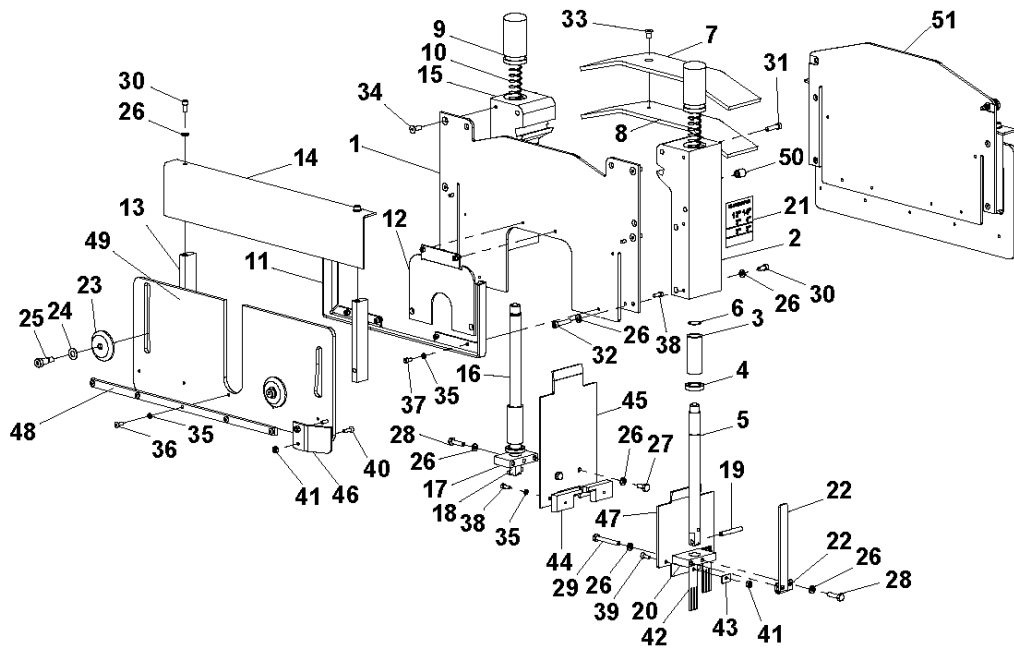



## BLADE BLOCK

SOFF CUT 5000, 2016-11

Ref	Part No	Description	Remark	QTY KIT
1	505 66 25-01	COVER	From page K	1
2	505 66 23-01	REAR BLOCK. B.B.		1
3	505 66 78-01	SHAFT		2
4	505 73 80-01	SEAL		2
5	505 66 34-01	SHAFT		1
6	505 74 84-01	SPIRAL RETAINING RING		2
7	505 66 18-01	COVER		1
8	505 66 17-01	COVER		1
9	505 66 35-01	CAP. B.B. SHAFT		2
10	505 66 37-01	SPRING		2
11	505 66 22-01	BRACKET		1
12	505 66 29-01	COVER		1
13	505 66 15-01	BLOCK. LEXAN MOUNT		2
14	505 66 19-01	COVER		1
15	505 66 24-01	FRONT BLOCK. B.B.		1
16	505 66 33-01	SHAFT		1
17	505 83 98-01	BLOCK		1
18	505 77 40-01	PLATE		1
19	587 91 82-01	PIN		1
20	505 66 49-01	BLOCK. SHAFT COLAR. B.B.		1
21	510 32 57-01	LABEL		1
22	505 83 17-01	DEPTH GAUGE ARM		1
23	505 76 17-01	WASHER		2
24	505 63 42-01	FLAT WSHR.750 X .375 X .031 SS		2
25	505 62 71-01	SHSH BOLT 3/8 X 5/8 BLK STL		2
26	505 63 28-01	LK WASH 1/4 SPLIT SS		12
27	505 62 74-01	HEX BOLT 1/4-20-5/8 S.S.		3
28	505 72 73-01	HEX BOLT 1/4-20-1 STAINLESS ST		2
29	505 72 81-01	HEX BOLT 1/4-20-2 S.S. ALL THR		1
30	505 72 23-01	SHC 1/4-20-1/2 S.S.		4
31	505 62 79-01	SHC 1/4-20-1 S.S.		2
32	505 62 80-01	SHC 1/4-20-1 1/4 S.S.		2
33	505 62 85-01	FHS 1/4-20-1/2 S.S.		2
34	505 62 86-01	FHS 1/4-20-3/4 S.S.		4
35	505 63 31-01	LK WASH #10 SPLIT SS		15
36	505 62 98-01	BHS 10-32-1/2 S.S.		5
37	505 62 77-01	SHC 10-32-3/8 S.S. NF		8
38	505 72 96-01	SHC 10-32 X 1/2 S.S. CBL MTS		6
39	505 73 02-01	FHS 10-24-5/8 S.S.		2
40	505 77 29-01	FHC 10-24 X 3/4 SS		2
41	505 63 04-01	NYLOC NUT #10-24 CAD.PL.		4
42	505 76 92-01	SMALL DUST FLAP		2
43	505 76 91-01	MTG. BAR FOR RUBBER FLAPS SML		2
44	505 66 16-01	BLOCK. FRONT DIVERTER		1
45	505 66 27-01	DIVERTER. B.B FRONT		1
46	505 76 15-01	SHIELD		1
47	505 66 28-01	DIVERTER. B.B REAR		1
48	505 66 43-01	STIFFENER		1
49	505 66 31-01	LEXAN. INNER		1
50	505 74 83-01	INSERT		2
51	505 86 25-01	BLADE		1

**N** SOFF CUT X5000  
BLADE BLOCK COVER ASSEMBLY

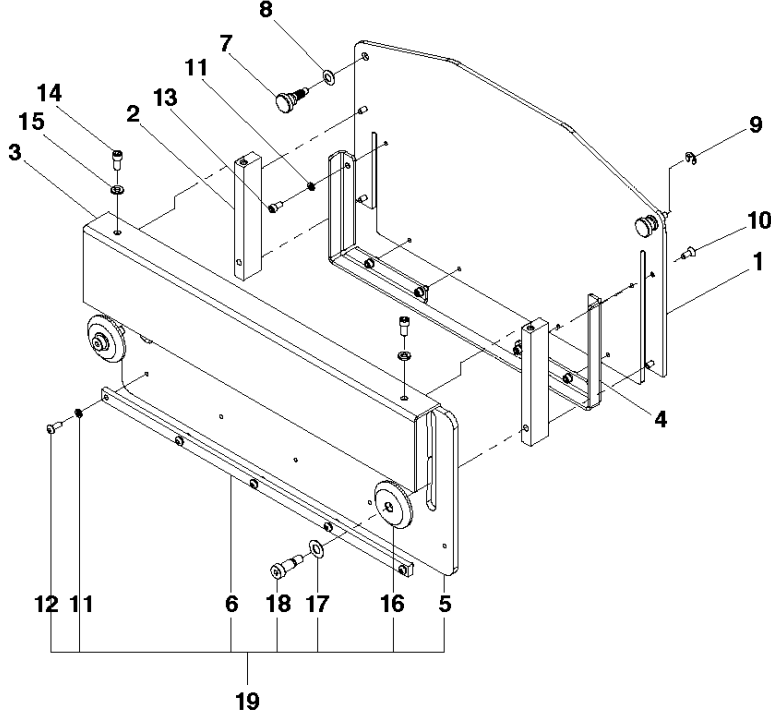

## BLADE BLOCK COVER

SOFF CUT 5000, 2016-11

Ref	Part No	Description	Remark	QTY KIT	
1	505 66 30-01	FRONT COVER		1	
2	505 66 15-01	BLOCK. LEXAN MOUNT		2	
3	505 66 21-01	COVER		1	
4	505 66 22-01	BRACKET		1	
5	505 66 32-01	LEXAN. OUTER		1	19
6	505 66 43-01	STIFFENER		1	19
7	505 53 63-01	KNOB		2	
8	505 53 64-01	WASHER		2	
9	505 53 65-01	E-CLIP		2	
10	505 72 99-01	FHS 10-32-1/2 S.S.		4	
11	505 63 31-01	LK WASH #10 SPLIT SS		11	19
12	505 62 98-01	BHS 10-32-1/2 S.S.		5	19
13	505 62 77-01	SHC 10-32-3/8 S.S. NF		6	
14	505 72 23-01	SHC 1/4-20-1/2 S.S		2	
15	505 63 28-01	LK WASH 1/4 SPLIT SS		2	
16	505 76 17-01	WASHER		2	19
17	505 63 42-01	FLAT WSHR.750 X .375 X .031 SS		2	19
18	505 62 71-01	SHSH BOLT 3/8 X 5/8 BLK STL		2	19
19	505 88 98-01	X5000 OUTER LEXAN		1	

**P** SOFF CUT X5000  
FUEL TANK ASSEMBLY

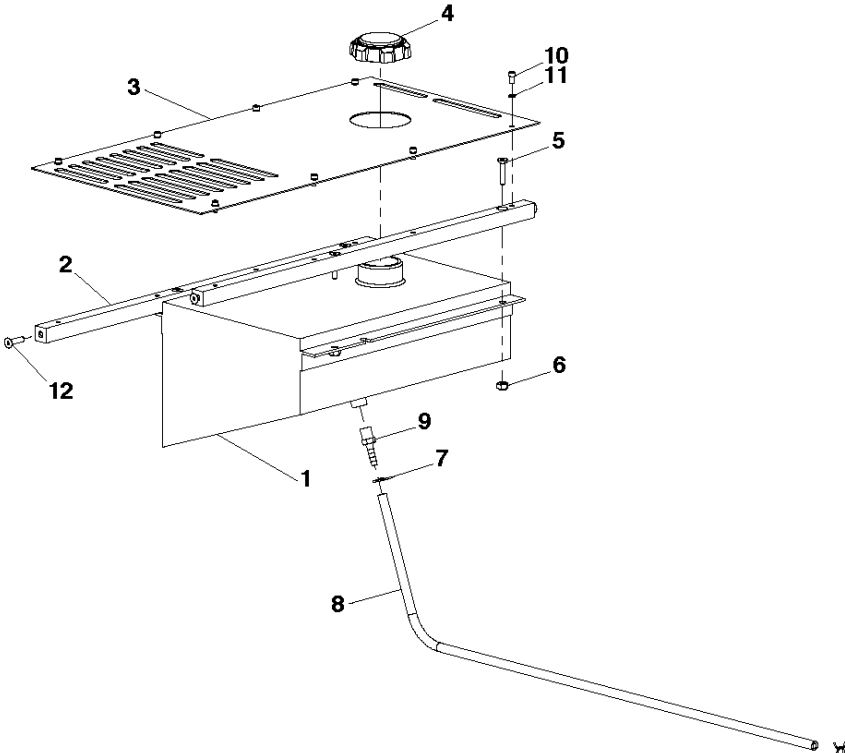

## FUEL TANK

SOFF CUT 5000, 2016-11

Ref	Part No	Description	Remark	QTY KIT
1	505 77 78-01	GAS TANK W/GAGE FOR G3000		1
2	505 79 20-01	HOOD		2
3	505 66 40-01	COVER		1
4	505 79 84-01	GAS SPRING		1
5	505 77 34-01	1/4-20 X 1 1/4 FLAT SOCKET SS		4
6	539 97 69-78	NUT		4
7	505 77 63-01	7/16 SPRING HOSE CLAMP		2
8	574 85 91-36	HOSE		1
9	541 20 47-99	FITTING		1
10	505 62 77-01	SHC 10-32-3/8 S.S. NF		8
11	505 63 31-01	LK WASH #10 SPLIT SS		8
12	505 62 87-01	FHS 1/4-20-1 S.S.		4

**Q** SOFF CUT X5000  
GUIDE ARM ASSEMBLY

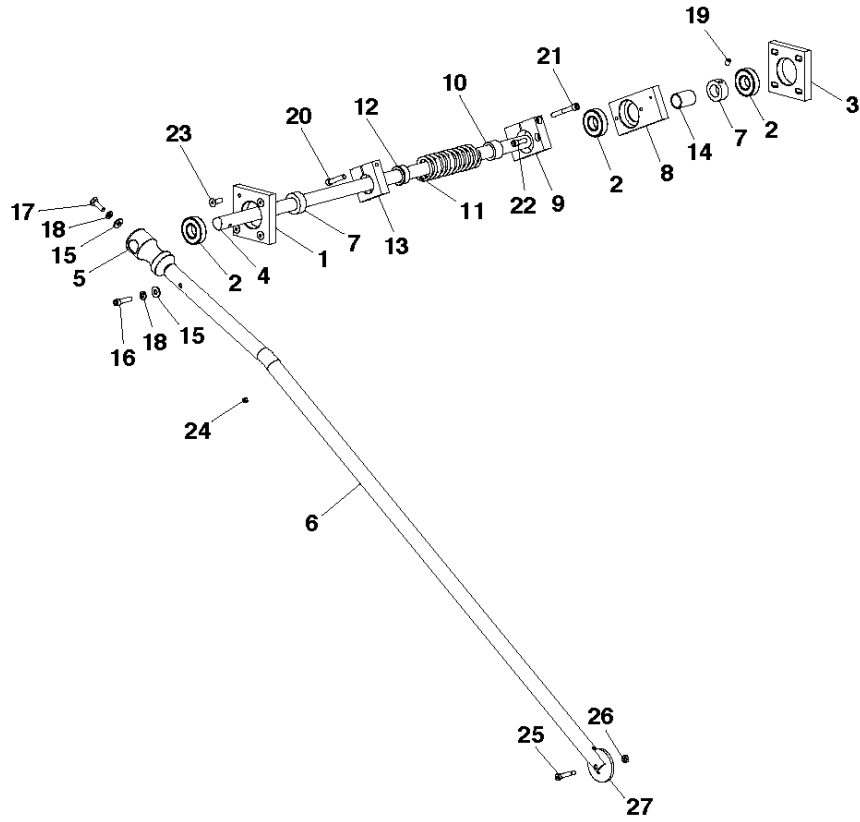

## GUIDE ARM ASSEMBLY

SOFF CUT 5000, 2016-11

Ref	Part No	Description	Remark	QTY KIT
1	505 71 37-01	PLATE MOUNTING GUIDE ARM		1
2	505 73 61-01	FRONT AXLE ASSY		3
3	505 71 38-01	PLATE MOUNT/GUIDE ARM ADJ.		1
4	505 66 41-01	SHAFT. GUIDE ARM		1
5	505 76 99-01	GUIDE		1
6	505 88 93-01	GUIDE		1
7	505 71 84-01	SHAFT. COLLAR 3/4"		2
8	505 71 71-01	SPRING		1
9	505 71 72-01	BLOCK		1
10	505 71 75-01	BUSHING		1
11	505 77 49-01	GUIDE		1
12	505 71 74-01	BUSHING		1
13	505 71 73-01	BLOCK		1
14	505 71 62-01	BUSHING		1
15	505 63 20-01	WASHER		2
16	505 62 79-01	SHC 1/4-20-1 S.S.		1
17	505 62 75-01	HEX BOLT 1/4-20-3/4 S.S.		1
18	505 63 28-01	LK WASH 1/4 SPLIT SS		2
19	542 02 05-41	SHSS,.25-20 X.375 CUP HK/CONCR		2
20	505 62 80-01	SHC 1/4-20-1 1/4 S.S.		1
21	505 72 89-01	SHC 1/4-20-2 S.S.		1
22	505 62 78-01	SHC 1/4-20-3/4 S.S.		2
23	505 62 86-01	FHS 1/4-20-3/4 S.S.		4
24	505 77 57-01	RUBBER BUMPER FOR GUIDE		1
25	505 77 17-01	SHSB 1/4 X 7/8		1
26	505 63 04-01	NYLOC NUT #10-24 CAD.PL.		1
27	505 61 42-01	DISC		1

**R** SOFF CUT X5000  
MAINFRAME ASSEMBLY

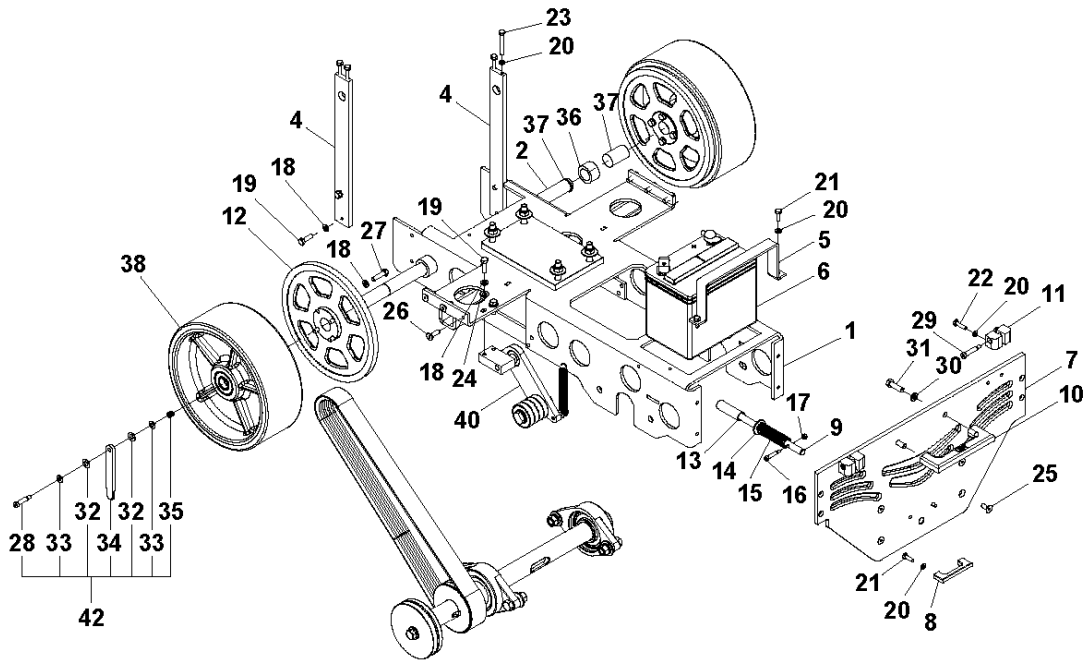



## MAINFRAME

SOFF CUT 5000, 2016-11

Ref	Part No	Description	Remark	QTY	KIT
1	505 65 70-01	MAINFRAME X5000 (SEND PRINT		1	
2	505 66 02-01	SHAFT. REAR AXLE		1	
3	505 65 69-01	ARM. CROSSBAR SUPPORT		2	
4	505 66 06-01	BRACKET. BATTERY TIE DOWN		1	
5	505 78 62-01	BATTERY		1	
6	505 66 11-01	FRONT PLATE		1	
7	505 71 42-01	GUARD ARBOR LOCK SHAFT		1	
8	505 76 43-01	ARBOR SHAFT		1	
9	505 71 69-01	HANDLES		1	
10	505 65 94-01	BLOCK. HOOD MOUNT		2	
11	505 86 98-01	REAR AXLE		2	
12	505 76 44-01	ARBOR LOCK 3/4 X 2.35		1	
13	505 73 14-01	FLAT WASH 1/2 X 1 1/4 O.D. S.S		1	
14	505 73 72-01	SPRING		1	
15	505 72 59-01	SHSB 1/4 X 1 BLK STL		1	
16	505 63 04-01	NYLOC NUT #10-24 CAD.PL.		1	
17	505 63 30-01	LK WASH 5/16 SPLIT SS		14	
18	539 99 02-09	BOLT		6	
19	505 63 28-01	LK WASH 1/4 SPLIT SS		12	
20	505 62 75-01	HEX BOLT 1/4-20-3/4 S.S.		4	
21	505 68 69-01	HEX BOLT 1/4-20 X 1 GRADE 8		4	
22	505 72 81-01	HEX BOLT 1/4-20-2 S.S. ALL THR		4	
23	539 99 01-88	WASHER		2	
24	505 62 88-01	FHS 5/16-18-3/4 S.S.		4	
25	505 73 01-01	FHS 5/16-18-1 S.S.		6	
26	505 72 84-01	HEX BOLT 5/16-18 X 1 1/4 GRADE		8	
27	505 72 67-01	SHSB 5/16 X 1 BLK STL		1	42
28	505 72 66-01	SHSB 5/16 X 1 1/4 BLK STL		2	
29	505 73 10-01	LK WASH 3/8 SPLIT SS		2	
30	539 97 69-41	SCREW		2	
31	505 63 45-01	FLAT WSHR .750X.379 X.031 DEL		2	42
32	505 72 50-01	FLT WSH 5/16 I.D. TRA 512		2	42
33	505 71 85-01	REAR AXLE		1	42
34	505 63 60-01	SPRING		1	42
35	505 66 42-01	SPACER		2	
36	542 20 62-05	SNAP RING		4	
37	505 87 10-01	WHEEL ASSY		2	
40	505 88 77-01	GX4000 REAR GUIDE ARM		1	

**S** SOFF CUT X5000  
PUMP CROSSBAR ASSEMBLY

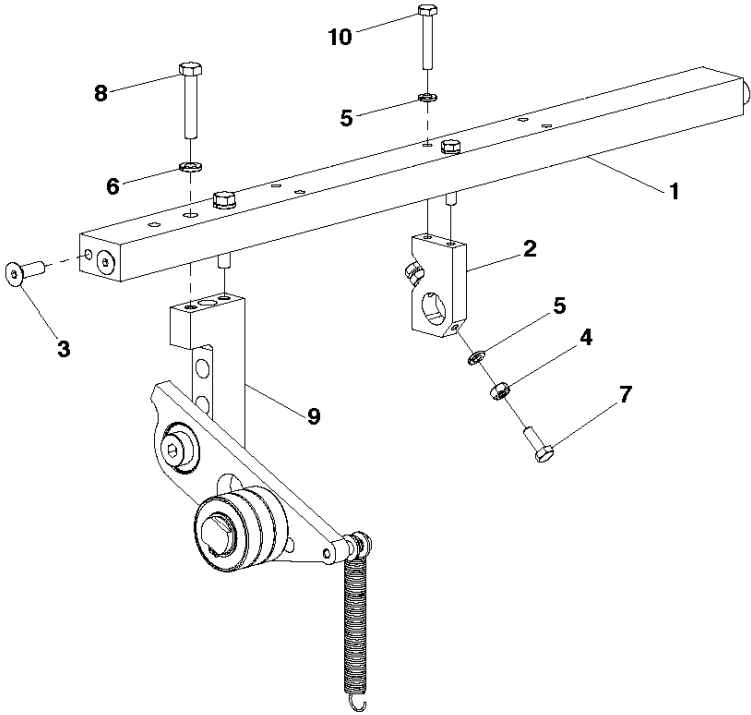

## PUMP CROSS BAR ASSEMBLY

SOFF CUT 5000, 2016-11

Ref	Part No	Description	Remark	QTY KIT
1	505 66 07-01	CROSSBAR		1
2	505 65 83-01	BLOCK. PUMP PIVOT		1
3	505 73 01-01	FHS 5/16-18-1 S.S.		4
4	505 63 19-01	JAM NUT 1/4-20 STAINLESS STEEL		2
5	505 63 28-01	LK WASH 1/4 SPLIT SS		4
6	505 63 30-01	LK WASH 5/16 SPLIT SS		2
7	505 62 75-01	HEX BOLT 1/4-20-3/4 S.S.		2
8	510 29 84-01	5/16-18 X 1 3/4 HEX BOLT GRD5		2
9	510 27 18-01	ASSEMBLY		1
10	505 72 83-01	HEX BOLT 1/4-20 X 1 1/4" ALL T		2

**T** SOFF CUT X5000  
REAR ACCESS ASSEMBLY

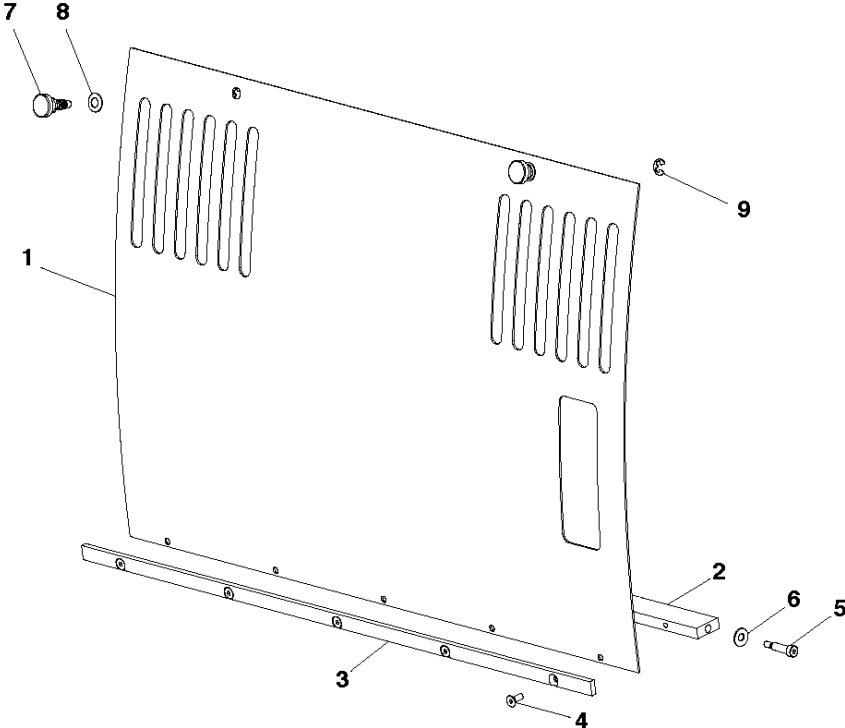

## REAR ACCESS ASSEMBLY

SOFF CUT 5000, 2016-11

Ref	Part No	Description	Remark	QTY KIT
1	505 79 16-01	REAR AXLE		1
2	505 66 08-01	CROSSBAR		1
3	505 76 71-01	BACK PANEL BRACE		1
4	505 72 99-01	FHS 10-32-1/2 S.S.		5
5	505 72 58-01	SHSB 1/4 X 3/4 BLK STL		2
6	505 63 44-01	WASHER		2
7	505 53 63-01	KNOB		2
8	505 53 64-01	WASHER		2
9	505 53 65-01	E-CLIP		2

**U** SOFF CUT X5000  
KIT, GUIDE ACTUATOR

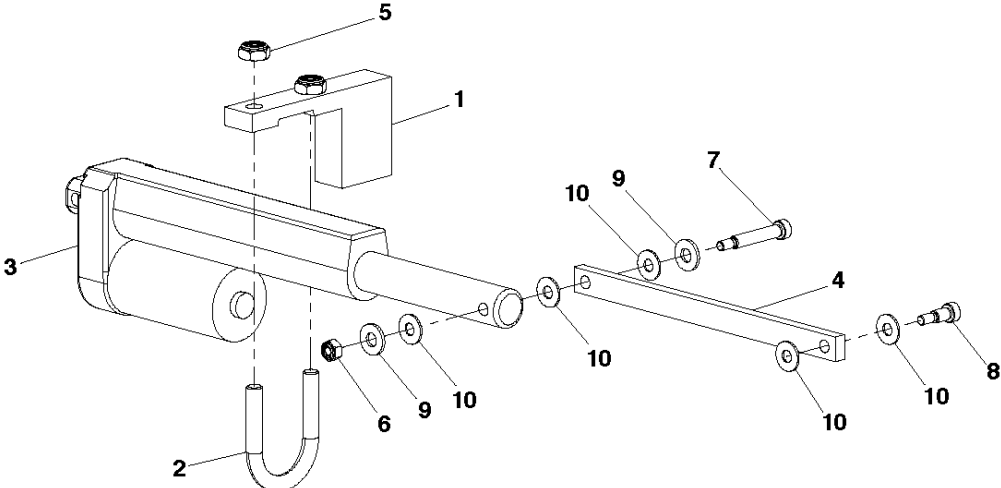

Ref	Part No	Description	Remark	QTY	KIT
1	505 79 24-01	ACTUATOR		1	3
2	575 42 13-01	CLAMP		1	3
3	505 84 80-02	KIT	Complete guide	1	
4	505 76 55-01	THROTTLE EXTENSION		1	3
5	505 63 17-01	NYLOC NUT 5/16-18 .265"HT.		2	3
6	505 63 04-01	NYLOC NUT #10-24 CAD.PL.		1	3
7	505 81 17-01	SHSB 1/4 X 1 1/4		1	3
8	505 68 64-01	SHSB 1/4 X 3/8 BLK STL		1	3
9	505 63 20-01	WASHER		2	3
10	505 63 44-01	WASHER		5	3

**V** SOFF CUT X5000  
KIT, THROTTLE ACTUATOR

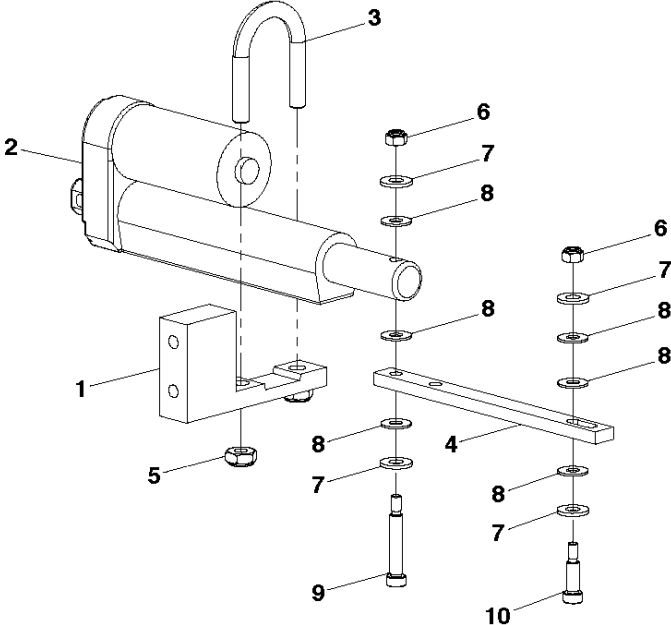



## THROTTLE CONTROLS

SOFF CUT 5000, 2016-11

Ref	Part No	Description	Remark	QTY	KIT
1	505 79 24-01	ACTUATOR		1	2
2	505 84 79-02	KIT	Complete Throttle Actuator	1	
3	575 42 13-01	CLAMP		1	2
4	505 79 22-01	THROTTLE EXTENSION		1	2
5	505 63 17-01	NYLOC NUT 5/16-18 .265"HT.		2	2
6	505 63 04-01	NYLOC NUT #10-24 CAD.PL.		2	2
7	505 63 20-01	WASHER		4	2
8	505 63 44-01	WASHER		4	2
9	505 81 17-01	SHSB 1/4 X 1 1/4		1	2
10	505 72 57-01	SHSB 1/4 X 5/8 BLK STL		1	2

**X** SOFF CUT X5000  
PANEL ASSEMBLY

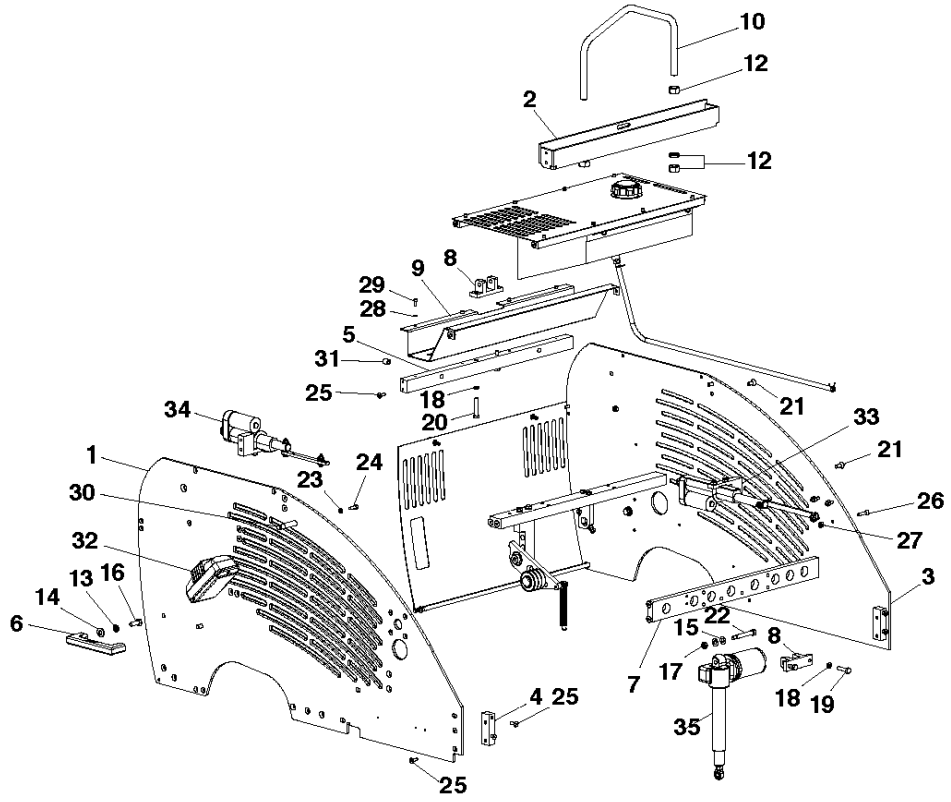

## PANEL ASSEMBLY

SOFF CUT 5000, 2016-11

Ref	Part No	Description	Remark	QTY KIT
1	505 66 10-01	SIDEPLATE. RIGHT		1
2	505 66 09-01	CROSSBAR		1
3	505 66 12-01	SIDEPLATE. LEFT		1
4	505 66 05-01	BLOCK. PANEL CORNER MOUNT		2
5	505 75 88-01	CROSS BAR REAR ACCESS		1
6	505 71 69-01	HANDLES		2
7	505 75 60-01	FRONT WHEEL SUPPORT		1
8	505 75 70-01	ACTUATOR		2
9	505 66 13-01	PANEL. REAR BIN		1
10	505 60 70-02	LIFTING HOOK		1
11	510 29 86-01	5/8-18 JAM NUT		6
12	505 73 10-01	LK WASH 3/8 SPLIT SS		4
13	510 30 10-01	WASHER		4
14	505 63 45-01	FLAT WSHR .750X.379 X.031 DEL		2
15	516 02 86-04	BOLT		4
16	53 99 07-17			1
17	505 63 30-01	LK WASH 5/16 SPLIT SS		4
18	505 72 84-01	HEX BOLT 5/16-18 X 1 1/4 GRADE		2
19	510 29 84-01	5/16-18 X 1 3/4 HEX BOLT GRD5		2
20	505 62 88-01	FHS 5/16-18-3/4 S.S.		12
21	505 62 72-01	SHSH BOLT 3/8 X 2 1/4" (WHEELS		1
22	505 63 28-01	LK WASH 1/4 SPLIT SS		1
23	505 62 75-01	HEX BOLT 1/4-20-3/4 S.S.		1
24	505 62 86-01	FHS 1/4-20-3/4 S.S.		14
25	505 77 34-01	1/4-20 X 1 1/4 FLAT SOCKET SS		4
26	539 97 69-78	NUT		6
27	505 63 31-01	LK WASH #10 SPLIT SS		4
28	505 72 96-01	SHC 10-32 X 1/2 S.S. CBL MTS		4
29	510 32 40-01	GUIDE ARM STOP		1
30	505 74 83-01	INSERT		2
31	505 75 22-01	FRONT AXLE ASSY		1
32	505 84 80-02	KIT		1
33	505 84 79-02	KIT		1
34	505 84 94-01	ACTUATOR		1

**Y** SOFF CUT X5000  
HOOD ASSEMBLY

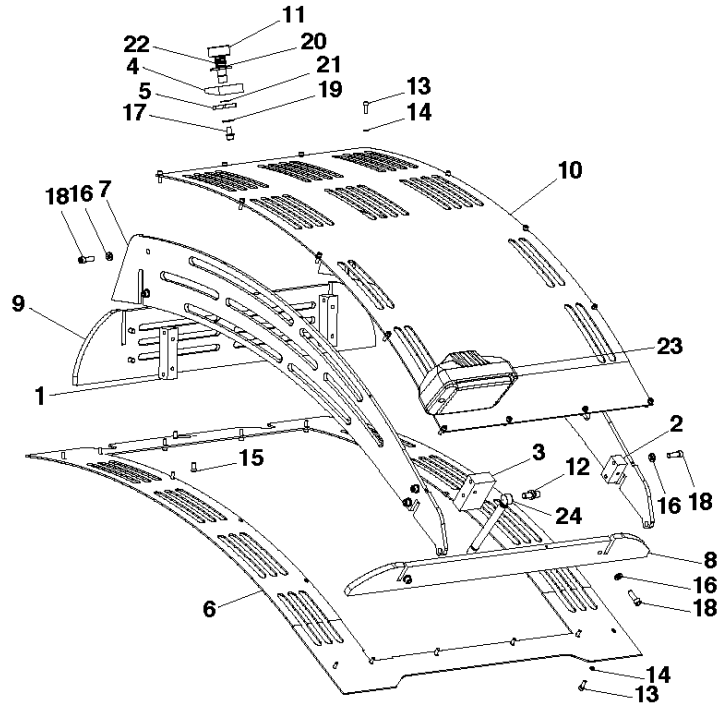

## HOOD

SOFF CUT 5000, 2016-11

Ref	Part No	Description	Remark	QTY KIT
1	505 65 91-01	BLOCK. REAR CORNER HOOD		2
2	505 65 92-01	BLOCK. FRONT CORNER HOOD		1
3	505 65 93-01	BLOCK. GAS SHOCK HOOD		1
4	505 65 95-01	BLOCK. HOOD LOCK		1
5	505 65 96-01	ARM. HOOD LOCK		1
6	510 32 27-01	PANEL. HOOD SKIRT		1
7	505 65 97-01	PLATE. SIDE HOOD		2
8	505 65 98-01	PLATE. FRONT HOOD		1
9	505 65 99-01	PLATE. REAR HOOD		1
10	510 32 29-01	PANEL. TOP HOOD		1
11	505 66 00-01	HOOD KNOB		1
12	505 73 82-01	BALL JOINT		1
13	505 62 82-01	SHC 8-32 X 1/2 S.S.		32
14	505 63 27-01	LK WASH #8 SPLIT S.S.		32
15	505 72 99-01	FHS 10-32-1/2 S.S.		2
16	505 63 28-01	LK WASH 1/4 SPLIT SS		15
17	505 72 23-01	SHC 1/4-20-1/2 S.S		1
18	505 62 78-01	SHC 1/4-20-3/4 S.S.		14
19	505 63 20-01	WASHER		1
20	505 73 14-01	FLAT WASH 1/2 X 1 1/4 O.D. S.S		1
21	505 64 78-01	1/2" SNAP RING		1
22	510 32 56-01	SPRING. HOOD LATCH		1
23	505 75 22-01	FRONT AXLE ASSY		1
24	505 73 81-01	GAS SHOCK (HOOD)		1