



SERVICE PARTS LIST

BUL. 54-36-0510

RIGHT ANGLE DRIVE

REVISED BUL. 639 DATE Feb. '68

MODEL NO. RAD-2

Starting Serial No. **39-1001**

WIRING INSTR.

Both Model and Serial No. must be furnished to obtain correct parts.

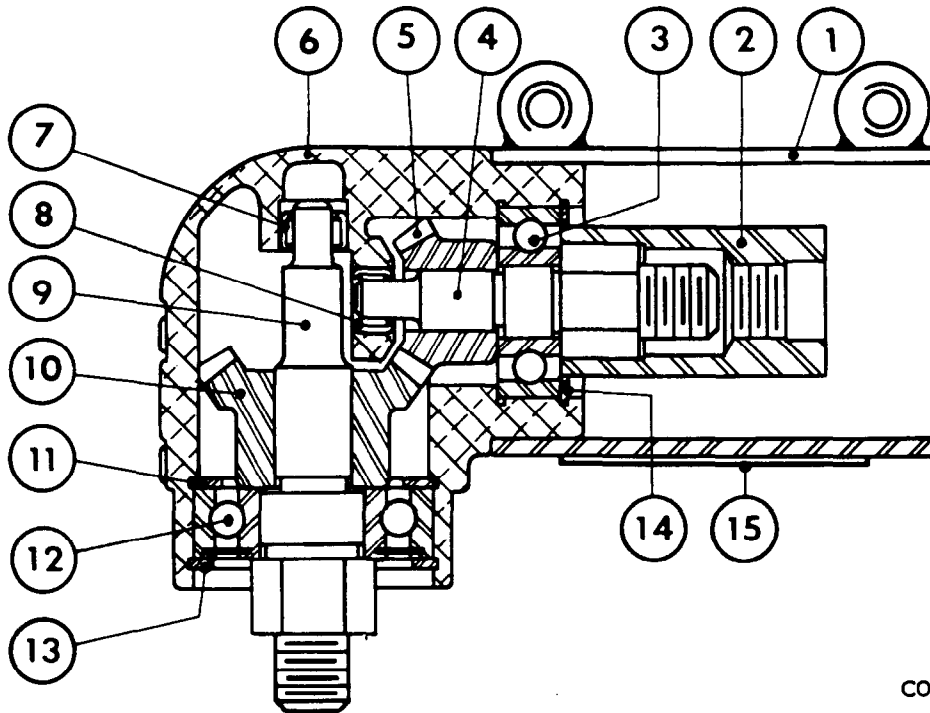

CORRECTS AND SUPERCEDES SERVICE BULLETIN 639 DATED 2/28/57

ILLUSTRATED PARTS FOR CURRENT MODEL

FIG.	PART NO.	DESCRIPTION OF PART	SEE NOTE	FIG.	PART NO.	DESCRIPTION OF PART	SEE NOTE
1	45-22-0120	Attachment Sleeve Assembly		8	02-50-1610	Needle Bearing	
2	42-90-0080	Female Coupling (Hex-one side)	A	9	38-50-2751	Spindle (Low Speed)	D
3	02-04-1230	Ball Bearing		10	32-05-1001	Large Bevel Gear (See Fig. 5)	
◆ 4	38-50-2901	Spindle (High Speed)	B	11	45-36-0140	Bearing Spacer	E
5	32-05-1021	Small Bevel Gear (Sold only in sets)		12	02-04-1740	Ball Bearing	
6	28-50-7551	Housing	C	13	34-80-2900	Tru-arc Snap Ring	
7	02-50-1610	Needle Bearing		14	34-80-2300	Tru-arc Snap Ring	
				15	12-98-3200	Name Plate	

MISCELLANEOUS PARTS (NOT ILLUSTRATED)

PART NO.	DESCRIPTION OF PART	PART NO.	DESCRIPTION OF PART
44-60-0170	Knock Out Pin (For 1/4" Chucks)	49-96-4060	Open End Wrench (9/16" & 11/16")
44-60-0190	Knock Out Pin (For 1/4" Chucks)	06-42-1200	Woodruff Keys (2)
06-75-0500	3/8-16x1 Hex. Hd. Cap Screws (2)	06-77-0450	4x1/4 Driv-In Name Plate Screws (2)
		42-90-0090	Hex-Two Sides (for use with S412 & S512)

NOTES - REPLACEMENT PARTS FOR OLDER MODELS

- A - Use 42-90-0065 below Serial No. 39-3150
- B - Use 38-50-2851 below Serial No. 39-3150
- C - Part no longer available below Serial No. 39-3150. Write factory for possible modification through use of new parts.
- D - Use 38-50-2701 below Serial No. 39-3150
- E - Use 45-36-0135 below Serial No. 39-3150

Numbers in brackets indicate number required.

◆ Reversing Spindles

Use 38-50-2951 in place of 38-50-2901 (above Serial No. 39-3150 only)
 Use 38-50-2801 in place of 38-50-2751 (above Serial No. 39-3150 only)