



R86039 18V Impact-Driver

KEY	P/N	DESCRIPTION	QTY
1	660435001	Screw (M3.5 x 22 mm, T15 Torx Pan Hd.).....	4
2	360391002	End Cap.....	1
3	204760003	Housing Assembly.....	1
4	692784001	Torsion Spring.....	1
5	527788001	LED Grip Light Switch.....	1
6	206759002	Motor, Switch & Pinion Assembly.....	1
7	611574018	Gear Ring.....	1
8	206758002	Hammer Assembly.....	1
9	941114115	Hot Surface Label.....	1
10	206757002	Gear Case and Bit Holder Assembly.....	1
11	680334044	Pin.....	2
12	533822001	Forward/Reverse Selector.....	1
13	660031029	Screw (M3.5 x 16 mm, T10 Torx Pan Hd.).....	8
14	941122098	Data Label.....	1
15	941001722	Mode Selector Label.....	1
16	360903001	Foot.....	1
17	660204008	Screw (M3 x 10 mm).....	2
18	532760001	Foot Cover.....	1
19	630206007	Bit Clip.....	1
20	670802041	Bit (#2 Phillips).....	1
21	636181001	Belt Hook.....	1
22	660212001	Screw (M4 x 6 mm).....	1

NOT SHOWN:

995000739 Operator's Manual (961153015)
2-27-19
(Rev:01)

R86039 18V Clé à chocs

PIÈCE RÉF.	DESCRIPTION	QTE
1	660435001 Vis (M3.5 x 22 mm, tête bombée Torx T15).....	4
2	360391002 Capuchon d'extrémité.....	1
3	204760003 Ensemble du boîtier.....	1
4	692784001 Ressort de torsion.....	1
5	527788001 Interrupteur de la lampe DÉL de la poignée.....	1
6	206759002 Interrupteur ensemble moteur et pignon.....	1
7	611574018 Couronne.....	1
8	206758002 Ensemble de percussion.....	1
9	941114115 Étiquette de surface brûlante.....	1
10	206757002 Ensemble de carter d'engrenages et porte-embout....	1
11	680334044 Goupille.....	2
12	533822001 Interrupteur avant/arrière.....	1
13	660031029 Vis (M3,5 x 16 mm, tête bombée Torx 10).....	8
14	941122098 Étiquette de données.....	1
15	941001722 Étiquette de sélecteur de mode...	1
16	360903001 Pied.....	1
17	660204008 Vis (M3 x 10 mm).....	2
18	532760001 Couvercle de pied.....	1
19	630206007 Clip à embout.....	1
20	670802041 Embout (Phillips no. 2).....	1
21	636181001 Crochet de courroie.....	1
22	660212001 Vis (M4 x 6 mm).....	1

PAS ILLUSTRÉ:

995000739 Manuel d'utilisation (961153015)

R86039 18V destornillador de impacto

REF. N/P	DESCRIPCIÓN	CANT.
1	660435001 Tornillo (M3.5 x 22 mm, cabeza tronc. Torx T15).....	4
2	360391002 Tapa del extremo.....	1
3	204760003 Conjunto de la armazón.....	1
4	692784001 Resorte de torsión.....	1
5	527788001 Interruptor de luz de diodo luminiscente en el mango.....	1
6	206759002 Interruptor conjunto de motor y piñón.....	1
7	611574018 Engrane anular.....	1
8	206758002 Conjunto de percusión.....	1
9	941114115 Etiqueta superficial caliente.....	1
10	206757002 Conjunto de la caja de engranajes y portapuntas.....	1
11	680334044 Pasador.....	2
12	533822001 Interruptor de adelante/atrás.....	1
13	660031029 Tornillo (M3.5 x 16 mm, cabeza tronc. Torx 10).....	8
14	941122098 Etiqueta de datos.....	1
15	941001722 Etiqueta de selector de modo.....	1
16	360903001 Pie.....	1
17	660204008 Tornillo (M3 x 10 mm).....	2
18	532760001 Cubierta del pies.....	1
19	630206007 Clip para la broca.....	1
20	670802041 Punta de destornillador (Phillips #2).....	1
21	636181001 Gancho de la correa.....	1
22	660212001 Tornillo (M4 x 6 mm).....	1

NO SE ILUSTRÁ:

995000739 Manual del operador (961153015)

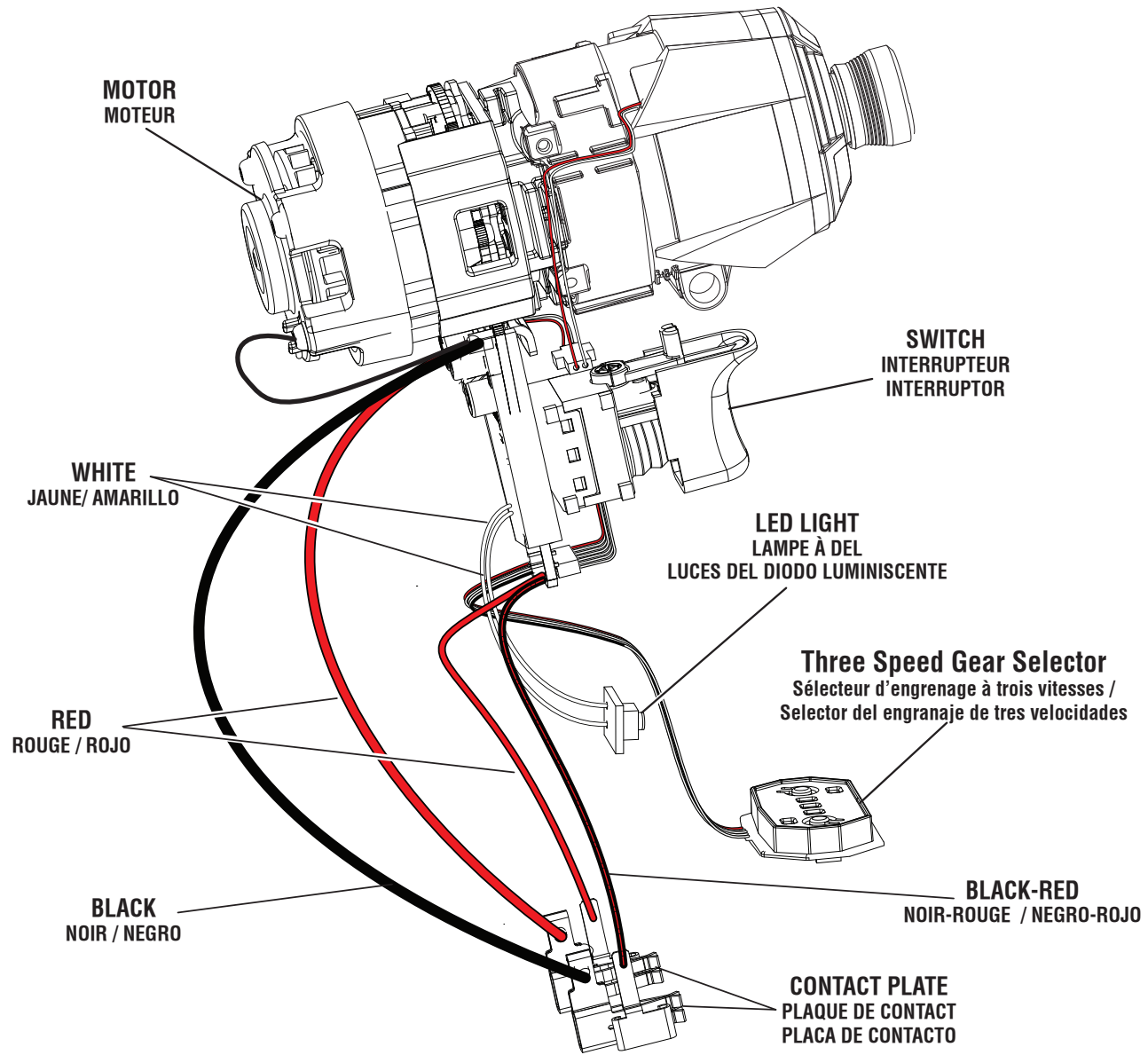

WIRING DIAGRAM / SCHÉMA DE CÂBLAGE / DIAGRAMA DE CABLEADO