

RIDGID® R855

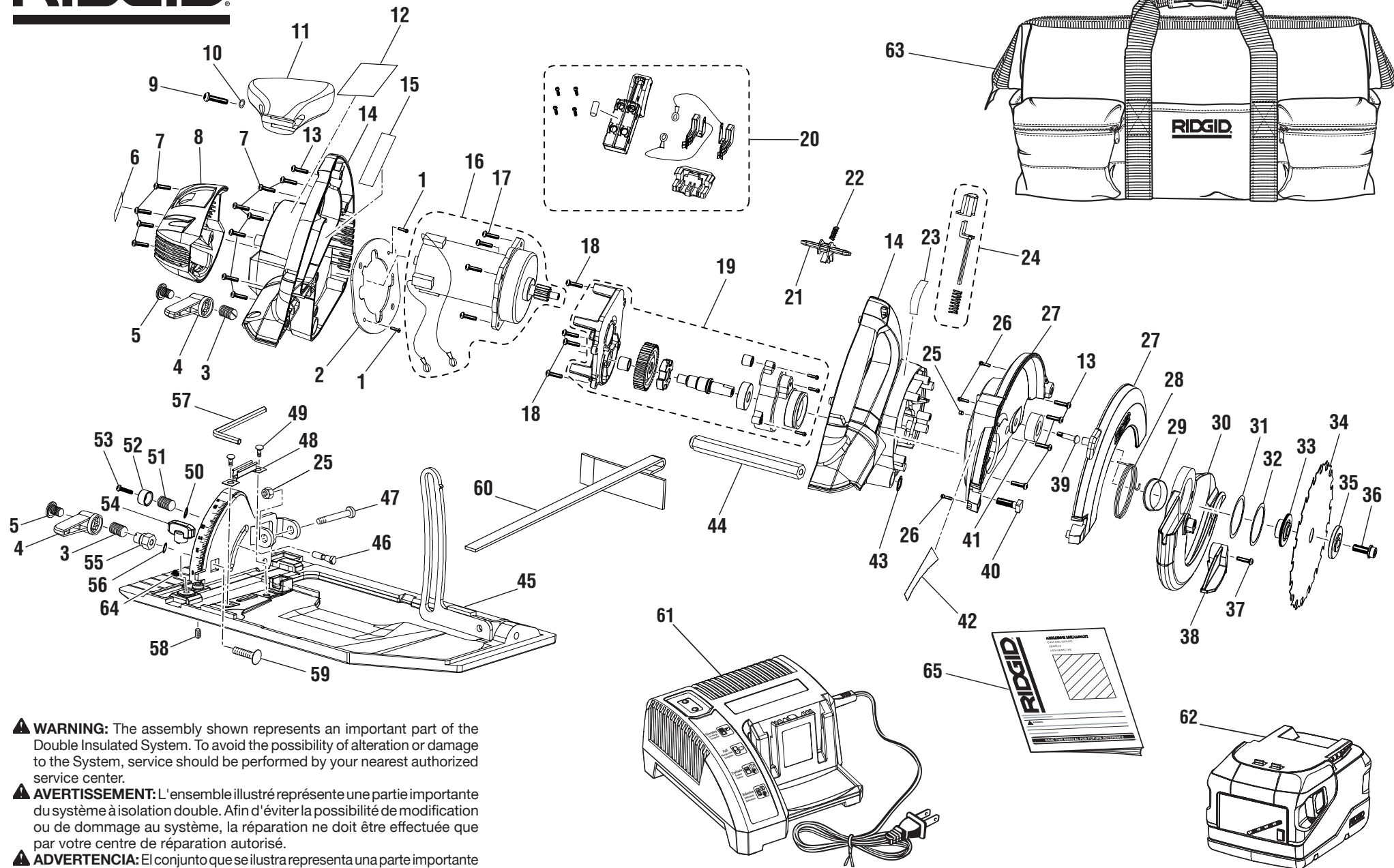

▲ WARNING: The assembly shown represents an important part of the Double Insulated System. To avoid the possibility of alteration or damage to the System, service should be performed by your nearest authorized service center.

▲ AVERTISSEMENT: L'ensemble illustré représente une partie importante du système à isolation double. Afin d'éviter la possibilité de modification ou de dommage au système, la réparation ne doit être effectuée que par votre centre de réparation autorisé.

▲ ADVERTENCIA: El conjunto que se ilustra representa una parte importante del Sistema de aislamiento doble. Para evitar la posibilidad de alteración o daño del sistema, la reparación debe ser efectuada en su centro de servicio autorizado.

KEY	P/N	DESCRIPTION	QTY	PIÈCE	RÉF.	DESCRIPTION	QTÉ	REF.	N/P	DESCRIPCIÓN	CANT.
1	660202001	* SCREW (M3 X 10 mm)	2	1	660202001	* VIS (M3 X 10 mm)	2	1	660202001	* TORNILLO (M3 X 10 mm)	2
2	901148001	INSULATOR	1	2	901148001	ISOLATEUR	1	2	901148001	AISLAMIENTO	1
3	681035001	SPRING	2	3	681035001	RESSORT	2	3	681035001	RESORTE	2
4	513965004	LEVER	2	4	513965004	LEVIER	2	4	513965004	PALANCA	2
5	660993001	* SCREW (1/4-20 x 7 mm)	2	5	660993001	* VIS (1/4-20 x 7 mm)	2	5	660993001	* TORNILLO (1/4-20 x 7 mm)	2
6	940999096	LOGO LABEL	1	6	940999096	PLAQUE DE LOGO	1	6	940999096	ETIQUETA DE LOGO	1
7	660024006	* SCREW (M4 X 22 mm)	11	7	660024006	* VIS (M4 X 22 mm)	11	7	660024006	* TORNILLO (M4 X 22 mm)	11
8	514430001	END CAP	1	8	514430001	COUVERCLE SUPÉRIEUR	1	8	514430001	TAPA DEL EXTREMO	1
9	660024011	* SCREW (M4 X 28 mm)	1	9	660024011	* VIS (M4 X 28 mm)	1	9	660024011	* TORNILLO (M4 X 28 mm)	1
10	680865001	WASHER	1	10	680865001	RONDELLE	1	10	680865001	ARANDELA	1
11	514432001	POMMEL	1	11	514432001	POMMEAU	1	11	514432001	PERILLA	1
12	940999095	DATA LABEL	1	12	940999095	PLAQUE DE DONNÉES	1	12	940999095	ETIQUETA DE DATOS	1
13	660024044	* SCREW (M4 X 16 mm)	5	13	660024044	* VIS (M4 X 16 mm)	5	13	660024044	* TORNILLO (M4 X 16 mm)	5
14	200381002	HOUSING SET ASSEMBLY	1	14	200381002	LOGEMENT	1	14	200381002	CONJ. DEL JUEGO DEL ALOJAMIENTO	1
15	940999092	WARNING LABEL	1	15	940999092	AUTOCOLLANT D'AVERTISSEMENT	1	15	940999092	ETIQUETA DE ADVERTENCIA	1
16	230049009	MOTOR ASSEMBLY	1	16	230049009	MOTEUR	1	16	230049009	CONJ. DEL MOTOR	1
17	6621213	* SCREW (M4 X 14.5 mm)	4	17	6621213	* VIS (M4 X 14.5 mm)	4	17	6621213	* TORNILLO (M4 X 14.5 mm)	4
18	6620803	* SCREW (M4 X 22 mm)	4	18	6620803	* VIS (M4 X 22 mm)	4	18	6620803	* TORNILLO (M4 X 22 mm)	4
19	200381003	GEAR CASE ASSEMBLY	1	19	200381003	BOÎTIER D'ENGRENAGES	1	19	200381003	CONJ. DEL CAJA DE ENGRANAJES	1
20	270017210	SWITCH ASSEMBLY	1	20	270017210	COMMUNTEUR	1	20	270017210	CONJ. DE LA INTERRUPTOR	1
21	514431001	SAFETY BUTTON	1	21	514431001	BOUTON DE SECURITÉ	1	21	514431001	BOTÓN SEGURIDAD	1
22	672029001	SPRING	1	22	672029001	RESSORT	1	22	672029001	RESORTE	1
23	940999091	DANGER LABEL	1	23	940999091	AUTOCOLLANT	1	23	940999091	ETIQUETA DE PELIGRO	1
24	300322024	SHAFT LOCK ASSEMBLY	1	24	300322024	VERROU D'AXE	1	24	300322024	CONJ. DE BLOQUEO DEL EJE	1
25	670974002	* NUT (M5)	2	25	670974002	* ECROU (M5)	2	25	670974002	* TUERCA (M5)	2
26	660165005	* SCREW (M4 X 12mm)	3	26	660165005	* VIS (M4 X 12mm)	3	26	660165005	* TORNILLO (M4 X 12mm)	3
27	200381004	UPPER BLADE GUARD ASSEMBLY	1	27	200381004	GARANT DE LAME SUPÉRIEUR	1	27	200381004	CONJ. DEL PROTECTOR SUPERIOR	1
28	680672002	TORSION SPRING	1	28	680672002	RESSORT DE TORSION	1	28	680672002	RESORTE DE TORSION	1
29	514307001	SLEEVE	1	29	514307001	MANCHON	1	29	514307001	MANGA	1
30	641126001	LOWER BLADE GUARD	1	30	641126001	GARANT DE LAME INFÉRIEUR	1	30	641126001	PROTECTOR INFERIOR	1
31	631771001	WASHER	1	31	631771001	RONDELLE	1	31	631771001	ARANDELA	1
32	691197001	SPIRAL RETAINING RING	1	32	691197001	ANNEAU DE RETENUE EN SPIRALE	1	32	691197001	ANILLO ESPIRAL DE RETENCIÓN	1
33	6112003	INNER BLADE WASHER	1	33	6112003	RONDELLE DE LAME INTERIEURE	1	33	6112003	ARANDELA INTERIOR DE LA HOJA	1
34	680477022	BLADE 6-1/2 in	1	34	680477022	LAME 6-1/2 po.	1	34	680477022	HOJA 165 mm (6-1/2 pulg)	1
35	610121003	OUTER BLADE WASHER	1	35	610121003	RONDELLE DE LAME EXTERIEURE	1	35	610121003	ARANDELA EXTERIOR DE LA HOJA	1
36	660144004	* SCREW (M6 X 16 mm)	1	36	660144004	* VIS (M6 X 16 mm)	1	36	660144004	* TORNILLO (M6 X 16 mm)	1
37	660151003	* SCREW (M5 X 10 mm PH)	1	37	660151003	* VIS (M5 X 10 mm PH)	1	37	660151003	* TORNILLO (M5 X 10 mm PH)	1
38	513955001	LOWER GUARD LEVER	1	38	513955001	LEVIER DE GARANT INFÉRIEUR	1	38	513955001	PALANCA DE PROTECTOR INFERIOR	1
39	660193003	* SCREW (M5 X 20 mm)	1	39	660193003	* VIS (M5 X 20 mm)	1	39	660193003	* TORNILLO (M5 X 20 mm)	1
40	660865001	* SCREW (M6 X 16 mm)	1	40	660865001	* VIS (M6 X 16 mm)	1	40	660865001	* TORNILLO (M6 X 16 mm)	1
41	560990001	STOPPER	1	41	560990001	BUTÉE	1	41	560990001	RETEN	1
42	940999090	DEPTH OF CUT SCALE LABEL	1	42	940999090	PLAQUE D'ÉCHELLE DE PROFONDEUR	1	42	940999090	ETIQUETA DE ESCALA DE LA PROF. DE CORTE	1
43	631771002	WASHER	1	43	631771002	DE COUPE	1	43	631771002	ARANDELA	1
44	672027001	HEX BAR	1	44	672027001	RONDELLE	1	44	672027001	BARRA HEXAGONAL	1
45	300322142	BASE ASSEMBLY	1	45	300322142	BARRE HEX.	1	45	300322142	CONJ. DE LA BASE	1
46	631687001	BEVEL PIN	1	46	631687001	BASE	1	46	631687001	PASADOR DE BISEL	1
47	660145005	* SCREW (M5 X 40 mm)	1	47	660145005	BROCHE DE BISEAU	1	47	660145005	* TORNILLO (M5 X 40 mm)	1
48	631717002	WRENCH RETENTION CLIP	1	48	631717002	* VIS (M5 X 40 mm)	1	48	631717002	PASADOR DE RETENCIÓN DE LA LLAVE	1
49	660219016	* SCREW (M5 X 5 mm)	2	49	660219016	CLIP DE RETENUE DE CLÉ	1	49	660219016	* TORNILLO (M5 X 5 mm)	2
50	513967001	WASHER	1	50	513967001	* VIS (M5 X 5 mm)	2	50	513967001	ARANDELA	1
51	681036001	BEVEL SPRING	1	51	681036001	RONDELLE	1	51	681036001	RESORTE DE BISEL	1
52	513968001	BEVEL BUTTON	1	52	513968001	RESSORT DE BISEAU	1	52	513968001	BOTÓN DE BISEL	1
53	661197001	* SCREW (M3 X 7 mm)	1	53	661197001	BOUTON DE BISEAU	1	53	661197001	* TORNILLO (M3 X 7 mm)	1
54	511165001	KNOB BOLT	1	54	511165001	* VIS (M3 X 8 mm)	1	54	511165001	PERNO DE PERILLA	1
55	660841001	* LEVER NUT (1/4 in.)	1	55	660841001	BOULON MOLETTE	1	55	660841001	* TUERCA DE PALANCA 6,35 mm (1/4 pulg)	1
56	691142001	WASHER	1	56	691142001	* ECROU DE LEVIER (1/4 po.)	1	56	691142001	ARANDELA	1
57	6800201	* HEX KEY (M5)	1	57	6800201	RONDELLE	1	57	6800201	* LLAVE HEXAGONAL (M5)	1
58	660066002	* SCREW (8/32 X 1/4 in.)	1	58	660066002	* CLÉ HEX. (M5)	1	58	660066002	* TORNILLO (8/32 X 1/4 pulg)	1
59	660858001	* CARRIAGE BOLT (1/4 X 20 X 3/4 in.)	1	59	660858001	* VIS (8/32 X 1/4 po.)	1	59	660858001	* PERNO DE CARRUAJE (1/4 X 20 X 3/4 pulg)	1
60	631697001	RIP GUIDE	1	60	631697001	* BOULON (1/4 X 20 X 3/4 po.)	1	60	631697001	GUIA DE CORTE AL HILO	1
61	140315001	CHARGER	1	61	140315001	GUIDE DE COUPE	1	61	140315001	CARGADOR	1
62	130377001	BATTERY PACK	1	62	130377001	CHARGEUR	1	62	130377001	PAQUETE DE PILAS	1
63	901614001	BAG	1	63	901614001	BLOC DE BATTERIES	1	63	901614001	BOLSA	1
64	680001002	SPRING	1	64	680001002	SACOCHÉ	1	64	680001002	RESORTE	1
65	983000923	OPERATOR'S MANUAL	1	65	983000923	RESSORT	1	65	983000923	MANUAL DEL OPERADOR	1
						MANUEL D'UTILISATION	1				

07-06-10
(REV:07)