



R4030 / R4030S

FIGURE A

KEY	P/N	DESCRIPTION	QTY	KEY	P/N	DESCRIPTION	QTY	KEY	P/N	DESCRIPTION	QTY
1	305364001	Table Assembly (Inc. Key Nos 2-25)	1	19	621416001	Eccentric Shaft.....	3	36	634287001	Miter Guide Plate	1
2	641935001	Table Support.....	1	20	670494002	Lock Nut (M6).....	5	37	660381004	Set Screw (M6 x 12 mm, Soc. Hd.)	2
3	661270002	Bolt (M6 x 20 mm, Hex Soc. Hd.).....	5	21	524822001	Guide Roller	3	38	305366001	Miter Guide Assembly (Inc. Key Nos 34, 36 and 39-44)	1
4	305341001	Table Lock Knob	1	22	661706002	Shoulder Screw (M8 x 33 mm, Hex Soc. Hd.)..	3	39	305330001	Lock Knob (Miter Guide).....	1
5	524766001	Lock Knob Cover	1	23	661705002	Set Screw (M4 x 4 mm, Soc. Hd.)	1	40	690523004	Washer (OD16.9 x ID6.2 x 1t).1	1
6	661734001	Screw (M4 x 14 mm, Pan Hd.)	4	24	941001014	No Hand Warning Label.....	2	41	661758001	Screw (M4 x 10 mm, Pan Hd.)	1
7	693363001	Lock Spring.....	1	25	941001015	Table Lock Label	1	42	634273001	Miter Guide Fence	1
8	673093001	Lock Pin	1	26	305267001	Frame Assembly (Inc. Key No. 27).....	1	43	305329001	Detent Knob (Miter Guide)	1
9	306784001	Roller Assembly	3	27	524693001	Frame Plug Cap	2	44	641936001	Miter Guide Bracket.....	1
10	525456001	Pump Elbow (90°)	1	28	305288001	Water Tray Assembly (Inc. Key No. 29).....	1	45	305367001	Pump Assembly (Inc. Key Nos 10-11,13 & 46) .	1
11	T941004006	Data Label (Pump)	1	29	305628001	Drain Plug Assembly.....	1	46	902734001	Pump Filter.....	2
12	693365001	Roller Small Spacer	3	30	693345001	Rail (Left)	1	47	693390001	Blade Wrench.....	1
13	941002012	Logo Label (Pump).....	1	31	693346001	Rail (Right).....	1	48	693391001	Hex Key (M6).....	1
14	611775001	Eccentric Sleeve	1	32	T661706001	Bolt (M8 x 14 mm, Hex Soc. Hd.).....	8	49	693523001	Hex Key (M2.5).....	1
15	661705001	Set Screw (M4 x 6 mm, Soc. Hd.)	1	33	634251001	Washer (OD17 x ID8.2 x 2t)....	8	Not Shown:			
16	T661707001	Lock Nut (M8).....	3	34	661763001	Screw (M4 x 8 mm, Pan Hd.)	2	990000035	Operator's Manual	1	
17	661706003	Shoulder Screw (M8 x 48 mm, Hex Soc. Hd.)..	3	35	524765001	Table Stop	2	3-13-13 (Rev:04)			
18	524821001	Fixed Roller	3								

FIGURE B / FIGURA B

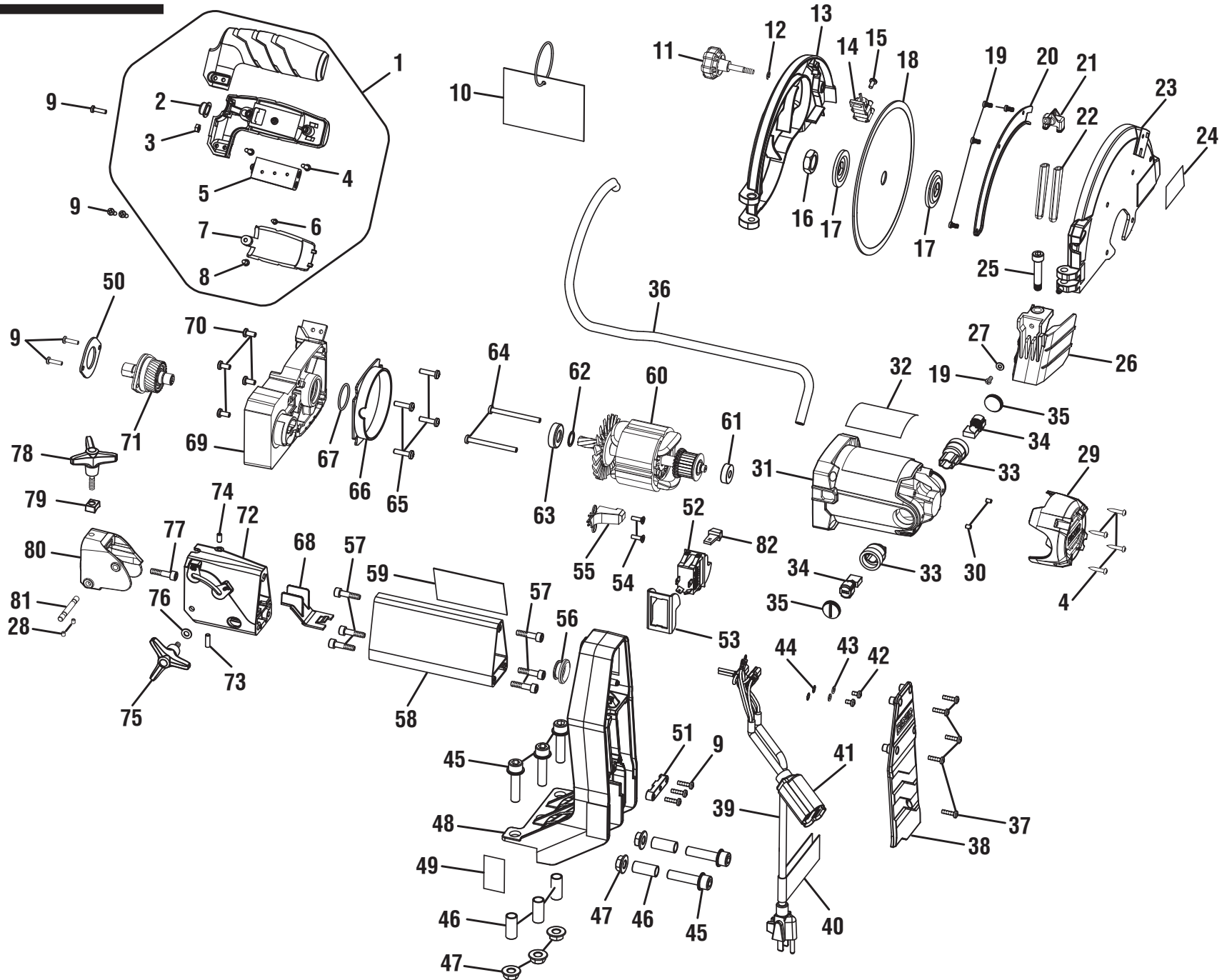



R4030 / R4030S

FIGURE B

KEY	P/N	DESCRIPTION	QTY	KEY	P/N	DESCRIPTION	QTY	KEY	P/N	DESCRIPTION	QTY
1	305388001	Handle Assembly (Inc. Key No. 2-8)	1	30	660067001	Set Screw (M4.5 x 9 mm, Soc. Hd.)	2	59	941004005	Data Label	1
2	570653002	Switch Cover	1	31	524753001	Motor Housing	1	60	230431001	Motor Assembly (Inc. Key No. 61-63)	1
3	680022004	Hex Nut (M4)	1	32	941001016	Warning Label (Eng)	1	61	680141018	Ball Bearing (608ZZ)	1
4	660208046	Screw (M4 x 16 mm, Pan Hd.)	6	33	513668001	Brush Holder Assembly	2	62	691140001	Retaining Ring	1
5	305360001	Battery Compartment	1	34	291131002	Brush Assembly	2	63	690191002	Ball Bearing (60012RS)	1
6	661736001	Screw (M4 x 8 mm, Pan Hd.)	1	35	512010001	Brush Holder Cap	2	64	660176014	Triangular Screw w/Washer (M4 x 58 mm)	2
7	524827001	Battery Compartment Cover	1	36	563002001	Hose	1	65	661735001	Screw (M5 x 17 mm, Pan Hd.)	4
8	660201003	Screw (M2.6 x 8 mm, Pan Hd.)	1	37	661762001	Screw (M4 x 10 mm, Pan Hd.)	5	66	524823001	Baffle	1
9	661734001	Screw (M4 x 14 mm, Pan Hd.)	8	38	524839001	Support Arm Cover	1	67	561341001	O-Ring	1
10	918003010	Warning Hang Tag (FR/SP)	1	39	730377058	Power Cord	1	68	524828001	Separation Plate	1
11	305330002	Blade Guard Locking Knob	1	40	941001018	Cord Danger Label	1	69	641940001	Gear Box	1
12	631225001	C-Ring	1	41	730377059	Pump Receptacle	1	70	661764001	Screw (M5 x 12 mm, Pan Hd.)	4
13	641942001	Outer Blade Guard	1	42	661763001	Screw (M4 x 8 mm, Pan Hd.)	2	71	220209001	Arbor Assembly	1
14	305365001	Laser Assembly	1	43	680866004	Spring Washer	2	72	641938001	Support Bracket (See Note A)	1
15	661763001	Screw (M4 x 8 mm, Pan Hd.)	1	44	692397001	External Toothed Spring Washer (OD8.5 x ID4.3)	2		641938002	Support Bracket (See Note B)	1
16	661511001	Flange Nut	1	45	661769001	Screw (M10 x 40 mm, Hex Soc. Hd.)	5	73	660384005	Set Screw (M5 x 16mm, Soc. Hd.)	1
17	634286001	Blade Flange	2	46	693366001	Sleeve	5	74	660384004	Set Screw (M5 x 10 mm, Soc. Hd.)	1
18	681647001	Blade Wheel	1	47	T661716001	Hex Nut (M10)	5	75	305328001	Detent Knob	1
19	T661761001	Screw (M3 x 6 mm, Pan Hd.)	5	48	641937001	Support Arm	1	76	634407001	Washer (OD15 x ID6.1 x 1t)	1
20	524825001	Hose Cover	1	49	941001020	Pump Receptacle Label	1	77	661270001	Bolt (M6 x 21 mm, Hex Soc. Hd.)	1
21	305368001	Nozzle Assembly	1	50	634211001	Bearing Plate	1	78	305328002	Knuckle Lock Knob	1
22	524849001	Nozzle	2	51	524844001	Cord Clip	1	79	T61177d4001	Stop Block	1
23	641941001	Inner Blade Guard	1	52	760271016	Switch (Use Before 1244)	1	80	641939001	Knuckle (See Note A)	1
24	941001017	Laser Warning Label	1		760271017	Switch (Use 1244 & Later)	1		641939002	Knuckle (See Note B)	1
25	661706004	Pivot Shaft	1	53	634493001	Switch Bracket	1	81	621428001	Knuckle Pivot Shaft	1
26	524853001	Splash Guard	1	54	T661737001	Screw (M4 x 8 mm, Pan Hd.)	2	82	525468001	Switch Key (Use Before 1244) ..	1
27	634513001	Washer (OD9 x ID3.1 x 0.8t)	1	55	524826001	Motor Outlet Cover	1		525468001	Switch Key (Use 1244 & Later)	1
28	661705001	Set Screw (M4 x 6 mm, Soc. Hd.)	2	56	563006001	Bend Relief	1				
29	524754001	Motor End Cap	1	57	661270003	Bolt (M6 x 20 mm, Hex Soc. Hd.)	6				
				58	693347001	Extrusion	1				

Note A: Models with serial numbers CS12284D300001-CS12284D300078 will need both Support Bracket and Knuckle listed.

Note B: Models with serial numbers CS12284D300079 and above will only need either Support Bracket or Knuckle needing to be replaced.

FIGURE C / FIGURA C

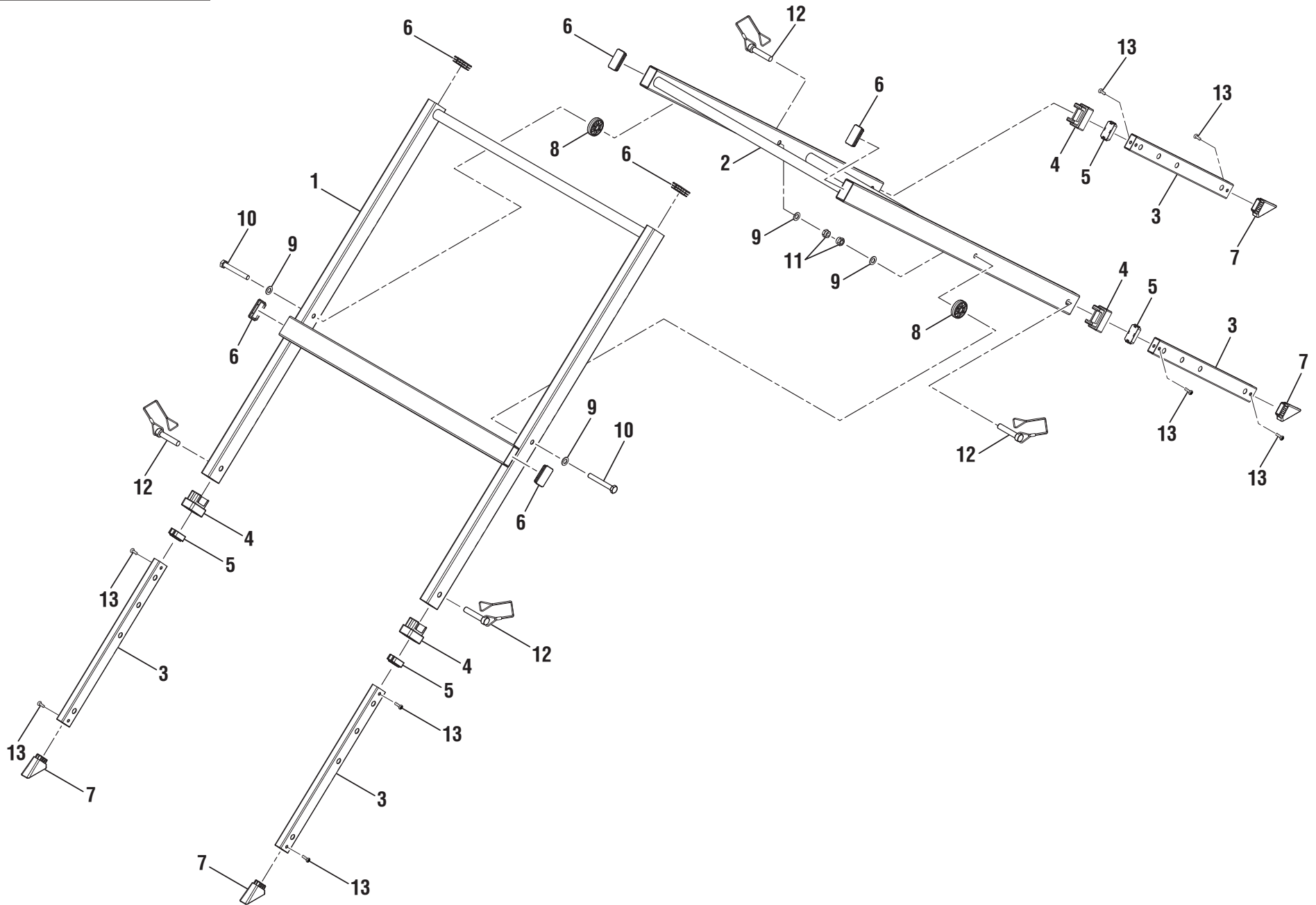



R4030 / R4030S

FIGURE C / FIGURA C

KEY	P/N	DESCRIPTION	QTY	CLÉ	NUM.	DESCRIPTION	QTÉ.	LLAVE	NÚM	DESCRIPCIÓN	CANT.
1	089260056701	Rail Bracket (Outside)	1	1	089260056701	Support de barre (extérieur)	1	1	089260056701	Support de riel (exterior).....	1
2	089260056702	Rail Bracket (Inside)	1					2	089260056702	Soporte de riel (interior).....	1
3	089260056010	Adjustment Leg	4	2	089260056702	Support de barre (intérieur)	1	3	089260056010	Pata de ajuste	4
4	089260056016	Sleeve.....	4	3	089260056010	Pied de réglage	4	4	089260056016	Manga	4
5	089260056018	Cap.....	4	4	089260056016	Manchon	4	5	089260056018	Tapa.....	4
6	089260056015	Stopper	6	5	089260056018	Capuchon.....	4	6	089260056015	Retén.....	6
7	089260056017	Foot.....	4	6	089260056015	Butée.....	6	7	089260056017	Pie	4
8	089260056014	Spacer.....	2	7	089260056017	Pied	4	8	089260056014	Separador	2
9	089260056012	Washer (ID8 x OD16 x 1.6t).....	4	8	089260056014	Pièce d'écartement	2	9	089260056012	Arruela (ID8 x OD16 x 1.6t).....	4
10	089260056013	Screw (M8 x 60 mm)	2	9	089260056012	Rondelle (ID8 x OD16 x 1.6t).....	4	10	089260056013	Tornillo (M8 x 60 mm).....	2
11	089260056011	Lock Nut (M8).....	2	10	089260056013	Vis (M8 x 60 mm).....	2	11	089260056011	Tuerca de seguridad (M8).....	2
12	089260056703	Lock Pin Assembly.....	4	11	089260056011	Écrou de blocage (M8)	2	12	089260056703	Conjunto de pasador de seguridad	4
13	089260037019	Screw (M4 x 10 mm)	8	12	089260056703	Ensemble de axe de blocage	4	13	089260037019	Tornillo (M4 x 10 mm).....	8
	089260056	Stand Assembly (Inc. Key Nos. 1-13).....	1	13	089260037019	Vis (M4 x 10 mm).....	8		089260056	Conjunto del banco (incl. núms. ref. 1-13).....	1
					089260056	Assemblage du stand (inclut les pièces 1-13)	1				