

**RIDGID
TILE SAW
MODEL NO. R4021
REPAIR SHEET**

**RIDGID
SCIE À CARREAUX
NUMÉRO DE MODÈLE R4021
FEUILLE DE RÉPARATION**

**RIDGID
SIERRA DE LOSAS
NÚMERO DE MODELO R4021
REPAIR SHEET**

FIGURE A / FIGURA A

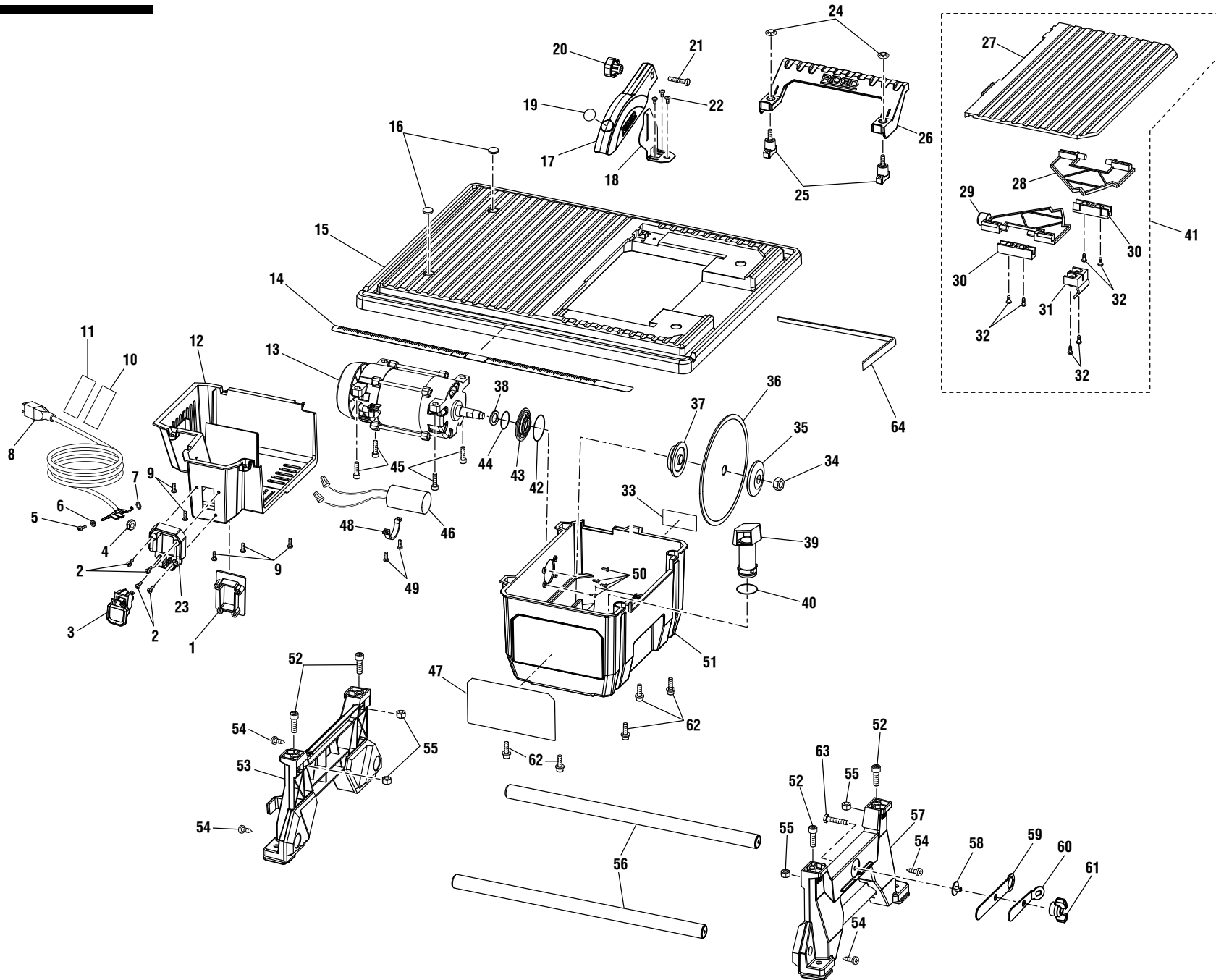



R4021

FIGURE A

KEY P/N	DESCRIPTION	QTY	KEY P/N	DESCRIPTION	QTY	KEY P/N	DESCRIPTION	QTY			
1	089009035075	Rear Switch Cover.....	1	23	089009035073	Front Switch Cover.....	1	45	089009035094	Screw (M6 x 25 mm).....	4
2	089009035072	Screw (M3.5 x 13 mm).....	4	24	089009035002	Push Nut (M6).....	2	46	089009035090	Capacitor.....	1
3	089009035071	On/Off Switch.....	1	25	089009035003	Rear Table Knob (Wing Screw, M6).....	2	47	089009035902	Warning/Logo Label.....	1
4	089009035070	Strain Relief.....	1	26	089009035701	Rear Table Support (Inc. Key Nos. 24-25).....	1	48	089009035093	Capacitor strap.....	1
5	089009035067	Screw (M5 x 8 mm).....	1	27	089009035041	Bevel Table.....	1	49	089009035092	Screw (M4 x 8 mm).....	2
6	089009035068	Spring Washer (M4).....	1	28	089009035043	Bevel Plate Support (Right).....	1	50	089009035099	Screw (M2.9 x 8 mm).....	4
7	089009035069	Washer (M4).....	1	29	089009035042	Bevel Plate Support (Left).....	1	51	089009035709	Cabinet (Inc. Key No. 33 and 47).....	1
8	089009035066	Power Cord Assembly.....	1	30	089009035044	Support Arm Base.....	2	52	089009035047	Bolt (M8 x 25 mm, Pan Hd.).....	4
9	089009035076	Screw (M4 x 12 mm).....	5	31	089009035046	Locking Block.....	1	53	089009035710	Left Table Leg Assembly.....	1
10	089041002906	Warning Cordwrap Label (FR/SP).....	1	32	089009035045	Screw (M5 x 12 mm).....	6	54	089009035061	Screw (M4.8 x 13 mm).....	4
11	089041002905	Danger Cordwrap Label.....	1	33	089009035901	Data Label.....	1	55	089009035053	Hex Nut (M8).....	4
12	089009035074	Motor Housing.....	1	34	089009035103	Arbor Nut.....	1	56	089009035711	Tube w/Plug.....	2
13	n/a	Motor Assembly (Inc. Key Nos. 38, 44 and 46).....	1	35	089009035102	Outer Wheel Washer.....	1	57	089009035712	Right Table Leg Assembly.....	1
14	089009035904	Scale Label.....	1	36	089009035905	Cutting Wheel.....	1	58	089009035062	Wrench Storage Bracket.....	1
15	089009035106	Table Assembly (Inc. Key Nos. 14 and 64).....	1	37	089009035100	Inner Wheel Washer.....	1	59	089009035063	Wheel Wrench.....	1
16	089009035107	Screw Cover (Plug).....	2	38	089009035088	Seal.....	1	60	089009035064	Arbor Wrench.....	1
17	089009035702	Splash Hood Assembly (Inc. Key Nos. 18-22).....	1	39	089009035104	Overflow Drain w/O-Ring (Inc. Key No. 40).....	1	61	089009035065	Wing Nut (Wrench Knob).....	1
18	089009035006	Splash Hood Bracket (Riving Knife)....	1	40	089009035105	O-Ring.....	1	62	089009035098	Screw (M6 x 16 mm).....	5
19	089009035903	No Hands Warning Label.....	1	41	089009035705	Bevel Table Assembly (Inc. Key Nos. 27-32).....	1	63	089009035059	Screw (M6 x 30 mm, Hex. Hd.).....	1
20	089009035005	Knob (M6).....	1	42	089009035096	O-Ring.....	1	64	089009035117	Sponge.....	1
21	089009035008	Screw (M6 x 25 mm, Hex Hd.).....	1	43	089009035095	Arbor Seal Assembly.....	1	Not Shown:			
22	089009035007	Screw (M4 x 6 mm, Pan Hd.).....	3	44	089009035089	O-Ring.....	1	995000122	Operator's Manual (089009035111)		
									5-10-17		
									(Rev:02)		

FIGURE B / FIGURA B

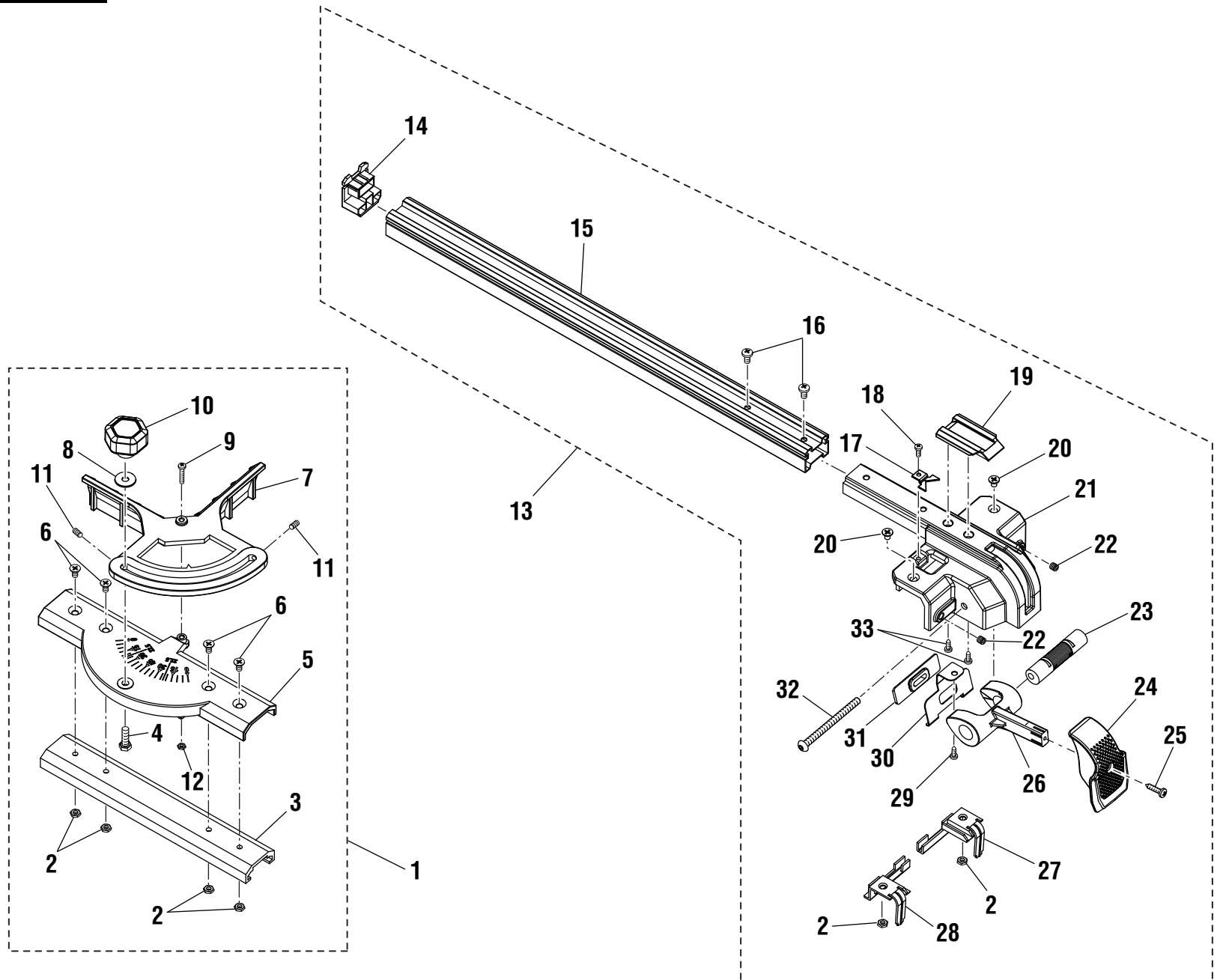
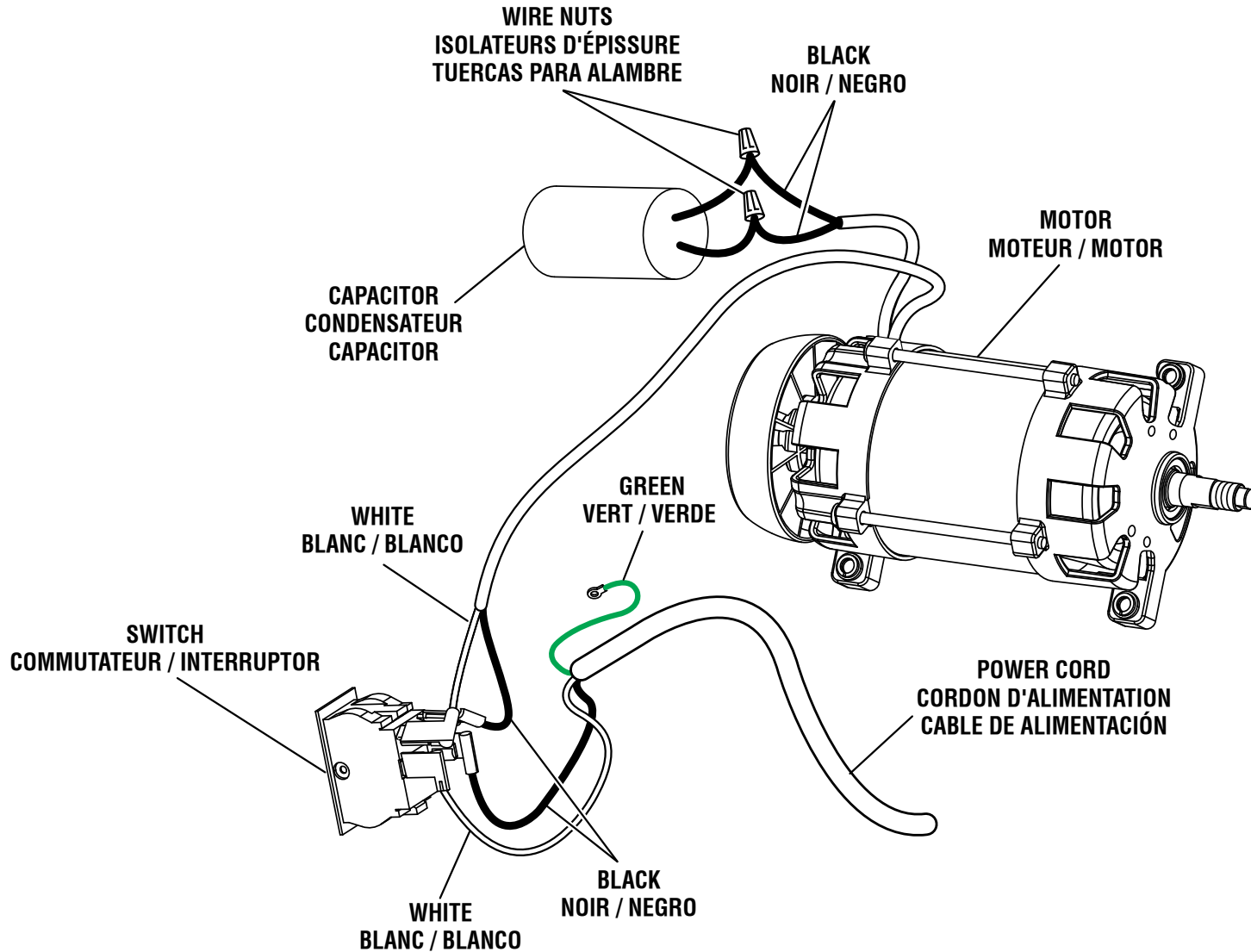

FIGURE B / FIGURA B

KEY P/N	DESCRIPTION	QTY	CLÉ NUM.	DESCRIPTION	QTÉ. LLAVE NÚM.	DESCRIPCIÓN	CANT.	
1 089009035703	Miter Gauge Assembly (Inc. Key Nos. 2-12).....	1	1 089009035703	Ensemble de guide d'onglet (incl. lég. réf. 2-12).....	1	1 089009035703	Conjunto de la guía de ingletes (incl. núm. ref. 2-12).....	1
2 089009035014	Hex Nut (M4).....	6	2 089009035014	Écrou (M4).....	6	2 089009035014	Hex Nut (M4).....	6
3 089009035012	Miter Gauge Support.....	1	3 089009035012	Support de guide d'onglet.....	1	3 089009035012	Soporte de la guía de ingletes.....	1
4 089009035013	Screw (M5 x 20 mm, Hex Hd.).....	1	4 089009035013	Vis (M5 x 20 mm, tête hex.).....	1	4 089009035013	Tornillo (M5 x 20 mm, cab. hex.).....	1
5 089009035011	Miter Gauge Bracket.....	1	5 089009035011	Support d'onglet coulissante.....	1	5 089009035011	Soporte de ingletes deslizable.....	1
6 089009035015	Screw (M4 x 8 mm, Pan Hd.).....	4	6 089009035015	Vis (M4 x 8 mm, tête bombée).....	4	6 089009035015	Tornillo (M4 x 8 mm, cab. tronc.).....	4
7 089009035010	Miter Gauge.....	1	7 089009035010	Guide d'onglet.....	1	7 089009035010	Guía de ingletes.....	1
8 089009035019	Washer (M5).....	1	8 089009035019	Rondelle (M5).....	1	8 089009035019	Arandela (M5).....	1
9 089009035016	Screw (M3 x 20 mm, Pan Hd.).....	1	9 089009035016	Vis (M3 x 20 mm, tête bombée).....	1	9 089009035016	Tornillo (M3 x 20 mm, cab. tronc.).....	1
10 089009035009	Knob (M6).....	1	10 089009035009	Bouton (M6).....	1	10 089009035009	Perilla (M6).....	1
11 089009035018	Screw (M4 x 8 mm).....	2	11 089009035018	Vis (M4 x 8 mm).....	2	11 089009035018	Tornillo (M4 x 8 mm).....	2
12 089009035017	Hex Lock Nut (M3).....	1	12 089009035017	Écrou de blocage six pans (M3).....	1	12 089009035017	Tuerca hexagonal de seguridad (M3) ..	1
13 089009035704	Rip Fence Assembly (Inc. Key Nos. 14-33).....	1	13 089009035704	Ensemble de guide longitudinal (incl. lég. réf. 14-33).....	1	13 089009035704	Eonjunto de la guía de corte al hilo (incl. núm. ref. 14-33).....	1
14 089009035039	Front Fence Cap.....	1	14 089009035039	Capuchon de guide avant.....	1	14 089009035039	Tapa de la guía frente.....	1
15 089009035037	Rip Fence.....	1	15 089009035037	Guide longitudinal.....	1	15 089003035037	Guía de corte al hilo.....	1
16 089009035038	Screw (M4 x 10 mm).....	2	16 089009035038	Vis (M4 x 10 mm).....	2	16 089009035038	Tornillo (M4 x 10 mm).....	2
17 089009035033	Fence Indicator.....	1	17 089009035033	Indicateur de guide.....	1	17 089009035033	Indicador de la guía.....	1
18 089009035034	Screw (M3 x 8 mm).....	1	18 089009035034	Vis (M3 x 8 mm).....	1	18 089009035034	Tornillo (M3 x 8 mm).....	1
19 089009035031	Fence Cap.....	1	19 089009035031	Capuchon de guide.....	1	19 089009035031	Tapa de la guía trasero.....	1
20 089009035032	Screw (M4 x 6 mm).....	2	20 089009035032	Vis (M4 x 6 mm).....	2	20 089009035032	Tornillo (M4 x 6 mm).....	2
21 089009035030	Fence Bracket.....	1	21 089009035030	Support de guide.....	1	21 089009035030	Soporte de guía.....	1
22 089009035040	Set Screw (M4 x 6 mm).....	2	22 089009035040	Vis d'arrêt (M4 x 6 mm).....	2	22 089009035040	Tornillo fijadore (M4 x 6 mm).....	2
23 089009035023	Eccentric Shaft.....	1	23 089009035023	Arbre de excentrique.....	1	23 089009035023	Eje del cojinete excéntrica.....	1
24 089009035021	Fence Locking Lever.....	1	24 089009035021	Guide de levier.....	1	24 089009035021	Guía de la palanca.....	1
25 089009035020	Screw (M4.2 x 16 mm).....	1	25 089009035020	Vis (M4.2 x 16 mm).....	1	25 089009035020	Tornillo (M4,2 x 16 mm).....	1
26 089009035022	Locking Wheel.....	1	26 089009035022	Meule de verrouillage.....	1	26 089009035022	Disco de seguridad.....	1
27 089009035028	Left Finger.....	1	27 089009035028	Doigt gauche.....	1	27 089009035028	Dedo izquierdo.....	1
28 089009035029	Right Finger.....	1	28 089009035029	Doigt droit.....	1	28 089009035029	Dedo derecho.....	1
29 089009035027	Screw (M4 x 6 mm).....	1	29 089009035027	Vis (M4 x 6 mm).....	1	29 089009035027	Tornilolo (M4 x 6 mm).....	1
30 089009035025	Locking Piece.....	1	30 089009035025	Pièce frein.....	1	30 089009035025	Pieza de fijación.....	1
31 089009035026	Rubber Gasket.....	1	31 089009035026	Joint en caoutchouc.....	1	31 089009035026	Junta de goma.....	1
32 089009035024	Screw (M5 x 65 mm).....	1	32 089009035024	Vis (M4 x 65 mm).....	1	32 089009035024	Tornillo (M4 x 65 mm).....	1
33 089009035036	Screw (M2.9 x 9.5 mm).....	2	33 089009035036	Vis (M2.9 x 9.5 mm).....	2	33 089009035036	Tornillo (M2,9 x 9,5 mm).....	2



WIRING DIAGRAM
SCHÉMA DE CÂBLAGE
DIAGRAMA DE CABLEADO