

RIDGID R3401

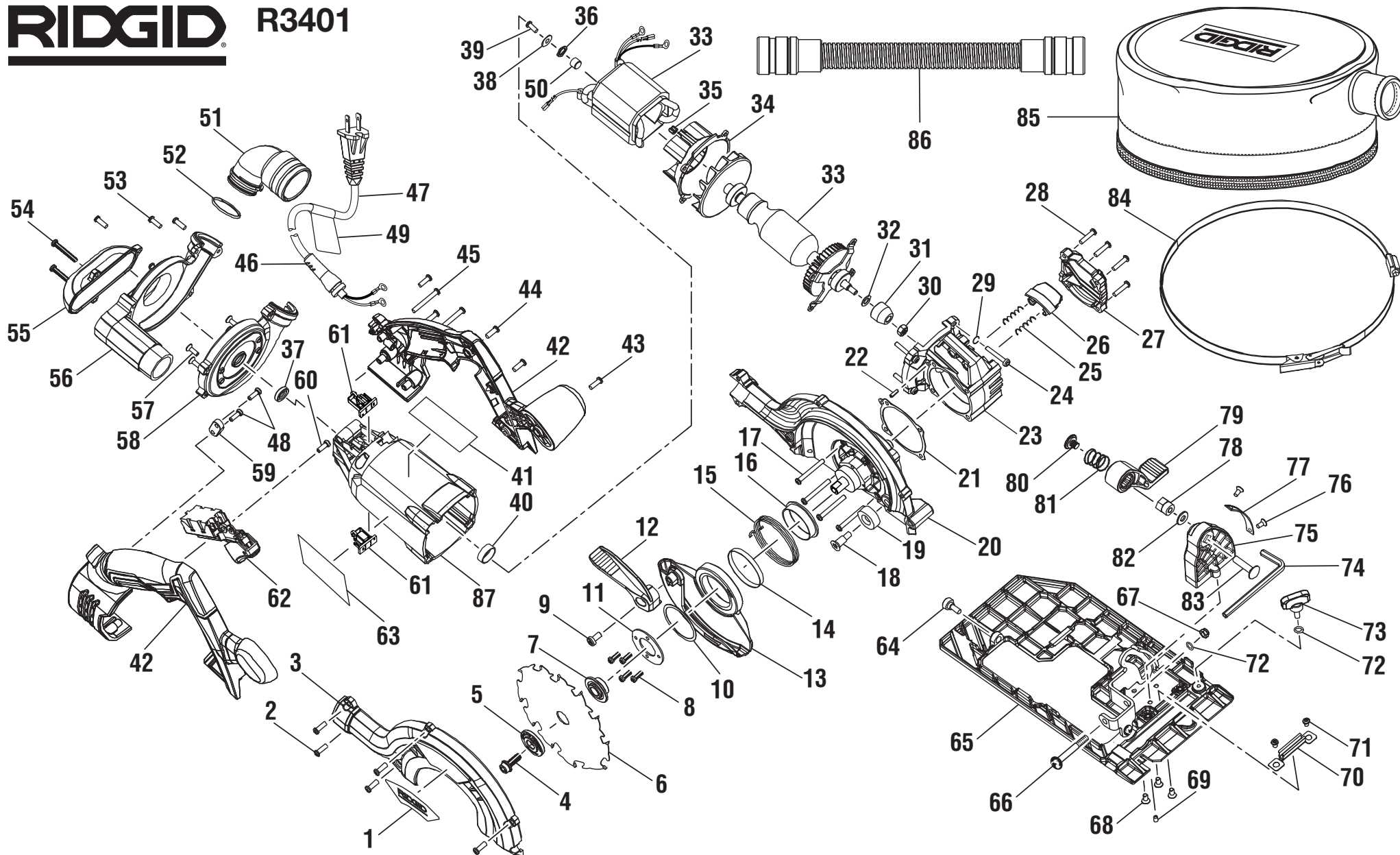

▲ **WARNING:** The assembly shown represents an important part of the Double Insulated System. To avoid the possibility of alteration or damage to the System, service should be performed by your nearest authorized service center.

▲ **AVERTISSEMENT :** L'ensemble illustré représente une partie importante du système à isolation double. Afin d'éviter la possibilité de modification ou de dommage au système, la réparation ne doit être effectuée que par votre centre de réparation centre commercial autorisé.

▲ **ADVERTENCIA:** El conjunto que se ilustra representa una parte importante del Sistema de Aislamiento Doble. Para evitar la posibilidad de alteración o daño del sistema, la reparación debe ser efectuada en su centro de servicio autorizado.

RIDGID® R3401

KEY	P/N	DESCRIPTION	QTY	KEY	P/N	DESCRIPTION	QTY	KEY	P/N	DESCRIPTION	QTY
1	632734001	LOGO PLATE.....	1	33	200146068	MOTOR ASSEMBLY.....	1	63	940304659	LOGO LABEL.....	1
2	660165013	SCREW (M4 x 12).....	5	34	517911001	BAFFLE.....	1	64	661173001	SCREW (M5 x 14 mm).....	1
3	302971001	UPPER GUARD COVER ASSEMBLY (INCL. KEY NO. 1).....	1	35	570638002	RUBBER CUSHION.....	2	65	302893001	BASE PLATE AND BRACKET ASSEMBLY.....	1
4	660818002	SCREW (M6 x 16 mm).....	1	36	631968001	WASHER.....	1	66	660145002	SCREW (M5 x 40, PAN HD. SHOULDER).....	1
5	610121007	OUTER BLADE WASHER.....	1	37	560144002	RUBBER OIL SEAL.....	1	67	670974002	LOCK NUT (M5).....	1
6	681310001	BLADE (5 in.).....	1	38	680335010	WASHER.....	1	68	661177001	SCREW (M4.0 x 7 mm, TORX T20).....	3
7	610120008	INNER BLADE WASHER.....	1	39	661586003	SCREW (M4 x 10 mm).....	1	69	660066005	ADJUSTMENT SCREW (8-32 x 1/4 in.)....	1
8	660031015	SCREW (M3 x 8 mm).....	4	40	560881002	RUBBER BEARING SEAT.....	1	70	631717002	WRENCH STORAGE CLIP.....	1
9	660151006	SCREW (M5 x 10 mm).....	1	41	940976595	DATA LABEL.....	1	71	660165014	SCREW (M4.0 x 5 mm, T20 TORX).....	2
10	631876001	WASHER.....	1	42	200634001	HANDLE ASSEMBLY.....	1	72	671237003	SPRING WASHER.....	2
11	680503002	COVER PLATE.....	1	43	660024044	SCREW (M4 x 16 mm).....	3	73	511129001	EDGE GUIDE LOCK KNOB.....	1
12	517838001	LOWER BLADE GUARD HANDLE.....	1	44	660024048	SCREW (M4 x 12 mm).....	3	74	6800201	HEX KEY (M6).....	1
13	641313001	LOWER BLADE GUARD.....	1	45	660024047	SCREW (M4 x 32 mm).....	4	75	641317001	QUADRANT.....	1
14	631685001	LOWER GUARD SLEEVE.....	1	46	560106001	BEND RELIEF.....	1	76	660374003	SCREW (M2.5 x 6 mm).....	2
15	691073001	TORSION SPRING.....	1	47	290376001	POWER CORD ASSEMBLY (INCL. KEY NO. 46 AND 49).....	1	77	632719001	BEVEL SCALE.....	1
16	513964001	LOWER GUARD SLEEVE (FLANGED).....	1	48	6627201	SCREW (M4 x 14 mm).....	2	78	660841014	HEX NUT (1/4-20).....	1
17	661175001	SCREW (M4 x 34 mm).....	4	49	940264111	CORD TAG LABEL.....	1	79	517912001	BASE RELEASE LEVER.....	1
18	660193003	SCREW (M5 x 20 mm).....	1	50	692275001	BUSHING.....	1	80	660993004	SCREW (1/4-20 x 1/4 in., LH THREAD, TORX T20).....	1
19	560990001	RUBBER STOPPER.....	1	51	517916001	DUST EJECTION PORT.....	1	81	681035001	COMPRESSION SPRING.....	1
20	302973001	UPPER GUARD SUPPORT ASSEMBLY (INCL. KEY NO. 22).....	1	52	560080001	O-RING.....	1	82	691142001	WASHER.....	1
21	902177001	GASKET.....	1	53	660024046	SCREW (M4 x 12 mm, T20 TORX).....	4	83	660858005	SCREW (1/4-20, LH THREAD).....	1
22	671019001	ROLL PIN.....	1	54	660024035	SCREW (M4 x 28 mm, T20 TORX).....	2	84	632864001	FILTER CLAMP.....	1
23	302972001	GEAR BOX ASSEMBLY.....	1	55	517712001	VOLUTE CAP.....	1	85	902245001	BUCKET CAP FILTER.....	1
24	660436006	SCREW (M4 x 25.4 mm).....	4	56	340713001	VOLUTE HOUSING COVER.....	1	86	560111001	HOSE.....	1
25	692245001	SPRING.....	2	57	660279011	SCREW (M4.0 x 12 mm).....	4	87	517716001	MOTOR HOUSING.....	1
26	517714001	SPINDLE LOCK BUTTON.....	1	58	517711001	VOLUTE HOUSING SUPPORT.....	1	NOT SHOWN:			
27	641318004	GEAR BOX CAP.....	1	59	5950101	CORD CLAMP.....	1	988000031	OPERATOR'S MANUAL.....	1	
28	661171001	SCREW (M4 x 17 mm).....	4	60	660208038	SCREW (M4 x 10 mm).....	1	6-28-11			
29	681022001	LOCK WASHER.....	4	61	290069080	BRUSH ASSEMBLY.....	2	(REV:04)			
30	671686001	HEX NUT (M5 x 0.8 mm).....	1	62	760405003	SWITCH.....	1				
31	T610476001	BEVEL PINION.....	1								
32	631385001	WASHER.....	1								