

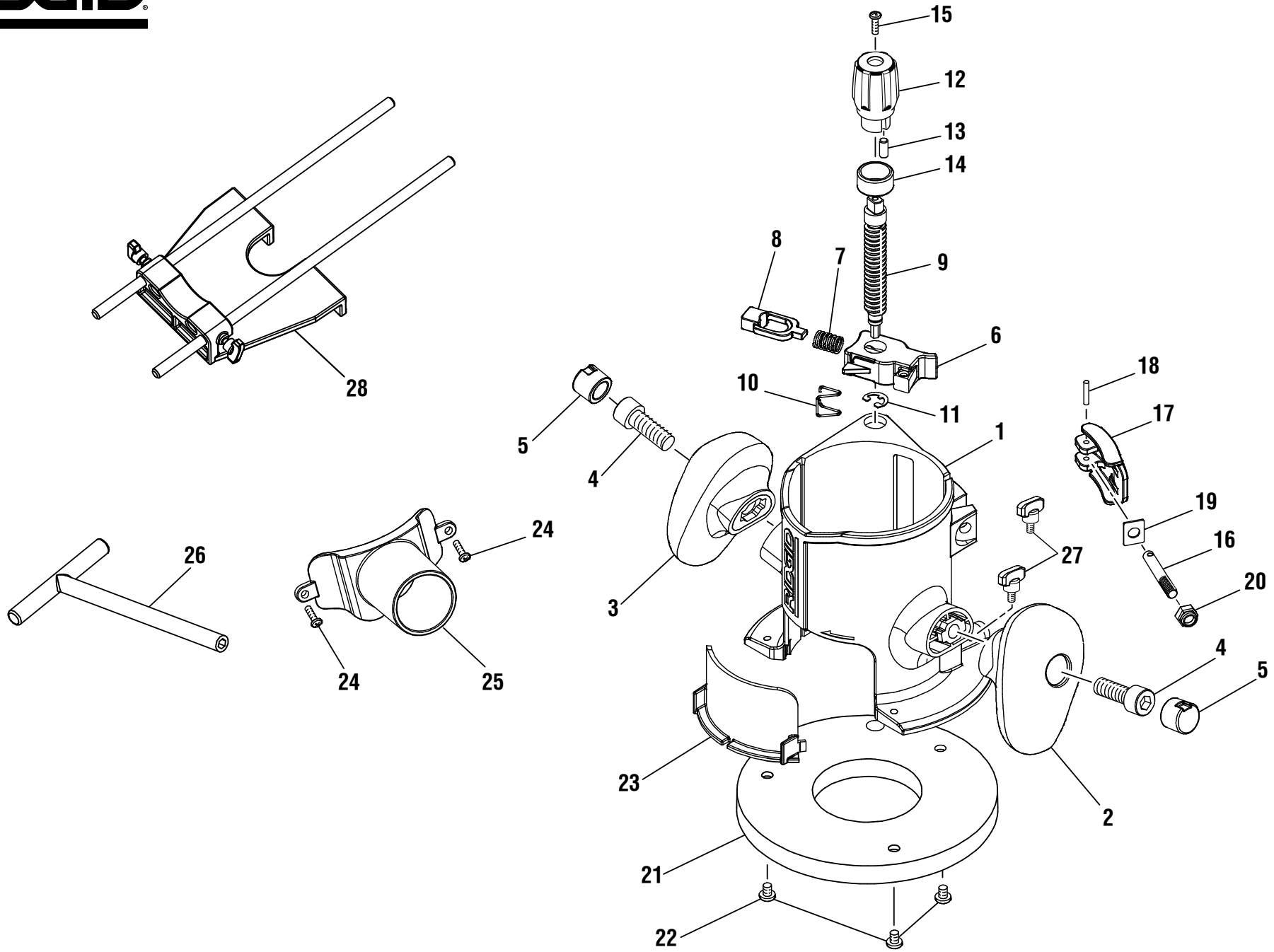

# R2911 Fixed Base Assembly / Base Fixe / Conjunto de la Base Fija





# R2911 Fixed Base Assembly / Base Fixe / Conjunto de la Base Fija

KEY	P/N	DESCRIPTION	QTY	PIÈCE	RÉF.	DESCRIPTION	QTÉ	REF.	N/P	DESCRIPCIÓN	CANT.
1	640925003	ROUTER BASE .....	1	1	640925003	BASE DE TOUPIE.....	1	1	640925003	BASE DE LA FRESADORA.....	1
2	513347002	RIGHT HANDLE ASSEMBLY .....	1	2	513347002	ENSEMBLE DE POIGNÉE DROITE .....	1	2	513347002	CONJUNTO DE MANGO DERECHO .....	1
3	513348002	LEFT HANDLE ASSEMBLY .....	1	3	513348002	ENSEMBLE DE POIGNÉE GAUCHE .....	1	3	513348002	CONJUNTO DE MANGO IZQUIERDO .....	1
4	660053003	BOLT (M10 x 28 mm, SOC. HD.) .....	2	4	660053003	BOULON (M10 x 28 mm, À TÊTE CREUSE) .....	2	4	660053003	PERNO (M10 x 28 mm, CAB. HUECA) .....	2
5	513395001	HANDLE PLUG .....	2	5	513395001	BOUCHON DE POIGNÉE.....	2	5	513395001	TAPÓN DEL MANGO.....	2
6	640963003	HEIGHT ADJUSTMENT HOUSING.....	1	5	513395001	BOUCHON DE POIGNÉE.....	2	6	640963003	ALOJAMIENTO DEL AJUSTE DE ALTURA ....	1
7	671758001	COMPRESSION SPRING .....	1	6	640963003	LOGEMENT DU RÉGLAGE DE HAUTEUR....	1	7	671758001	RESORTE .....	1
8	513396001	HEIGHT ADJUSTMENT SLIDE .....	1	7	671758001	RESSORT .....	1	8	513396001	CORREDERA DEL AJUSTE DE ALTURA .....	1
9	671757001	HEIGHT ADJUSTMENT SCREW .....	1	8	513396001	GLISSIÈRE DE RÉGLAGE DE HAUTEUR.....	1	9	671757001	TORNILLO DE AJUSTE DE ALTURA.....	1
10	671759001	TORSION SPRING .....	1	9	671757001	VIS DE RÉGLAGE DE HAUTEUR .....	1	10	671759001	RESORTE DE TORSIÓN.....	1
11	671797002	E-RING.....	1	10	671759001	RESSORT DE TORSION.....	1	11	671797002	ANILLO EN "E" .....	1
12	513093001	HEIGHT ADJUSTMENT KNOB .....	1	11	671797002	CLIP EN E.....	1	12	513093001	PERILLA DE AJUSTE DE ALTURA .....	1
13	570334001	RUBBER PLUG.....	1	12	513093001	BOUTON DE RÉGLAGE DE HAUTEUR .....	1	13	570334001	TAPÓN DE CAUCHO.....	1
14	340092001	ZERO RESET RING .....	1	13	570334001	BOUCHON EN CAOUTCHOUC .....	1	14	340092001	ANILLO DE AJUSTE A CERO .....	1
15	660320008	SCREW (M3.5 x 12 mm) .....	1	14	340092001	BAGUE DE REMISE À ZÉRO .....	1	15	660320008	TORNILLO (M3,5 x 12 mm).....	1
16	671260002	PIN .....	1	15	660320008	VIS (M3,5 x 12 mm) .....	1	16	671260002	PASADOR.....	1
17	201391001	LOCK LEVER ASSEMBLY (INCL. KEY NOS. 16 AND 18).....	1	16	671260002	AXE.....	1	17	201391001	CONJUNTO DE PASADOR DE LA PALANCA (INCL. PZAS. NÚMS. REF. 16 Y 18) .....	1
18	671247001	NEEDLE ROLLER PIN.....	1	17	201391001	ENSEMBLE DE AXE DE LEVIER (INCL. PIÈCES NO. 16 ET 18) .....	1	18	671247001	PASADOR DE ARTICULACIÓN DE LA AGUJA.....	1
19	631421001	WEAR PLATE .....	1	18	671247001	GOUPILLE CYLINDRIQUE D'AIGUILLES.....	1	19	631421001	PLACA DE ROZAMIENTO .....	1
20	671243003	LOCK NUT (HEX) .....	1	19	631421001	PLAQUE D'USURE.....	1	20	671243003	TUERCA DE SEGURIDAD (HEX.).....	1
21	513087001	SUBBASE .....	1	20	671243003	ÉCROU FREIN (HEX.).....	1	21	513087001	SUBBASE.....	1
22	660136003	SCREW (10-32 x 3/8 in.).....	3	21	513087001	SEMELLE.....	1	22	660136003	TORNILLO (10-32 x 3/8 pulg.).....	3
23	513094001	CHIP SHIELD .....	1	22	660136003	VIS (10-32 x 3/8 po).....	3	23	513094001	PROTECTOR CONTRA VIRUTAS.....	1
24	660169010	SCREW (#6-32 x 3/8 in., PAN HD.).....	2	23	513094001	PARE-COPEAUX .....	1	24	660169010	TORNILLO (#6-32 x 3/8 pulg., CAB. TRONCOCÓNICA ) .....	2
25	513349001	DUST COLLECTOR .....	1	24	660169010	VIS (#6-32 x 3/8 po, TÊTE BOMBÉE).....	2	25	513349001	COLECTOR DE POLVO.....	1
26	513667001	T-HANDLE WRENCH .....	1	25	513349001	COLLECTEUR DE POUSSIÈRE .....	1	26	513667001	LLAVE DE MANGO EN "T" .....	1
27	512777001	EDGE GUIDE KNOB .....	2	26	513667001	CLÉ EN T .....	1	27	512777001	PERILLA DE LA GUÍA DE BORDES .....	2
28	202318001	EDGE GUIDE .....	1	27	512777001	BOUTON DE GUIDE DE CHANT .....	2	28	202318001	GUÍA DE BORDES .....	1
<b>NOT SHOWN:</b>				<b>PAS ILLUSTRÉ :</b>				<b>NO SE ILUSTRÁ:</b>			
	660235013	SCREW (10-32 x 12 mm, ROUTER TABLE ATTACHMENT SCREWS).....	3		660235013	VIS (10-32 x 12 mm, VIS DE FIXATION DE TABLE À TOUPIE).....	3		660235013	TORNILLO (10-32 x 12 mm, TORNILLOS DEL ADITAMENTO DE MESA PARA FRESADORA) .....	3



# R29202 Plunge Base Assembly / Base Plongante / Conjunto de la Base Tipo Émbolo

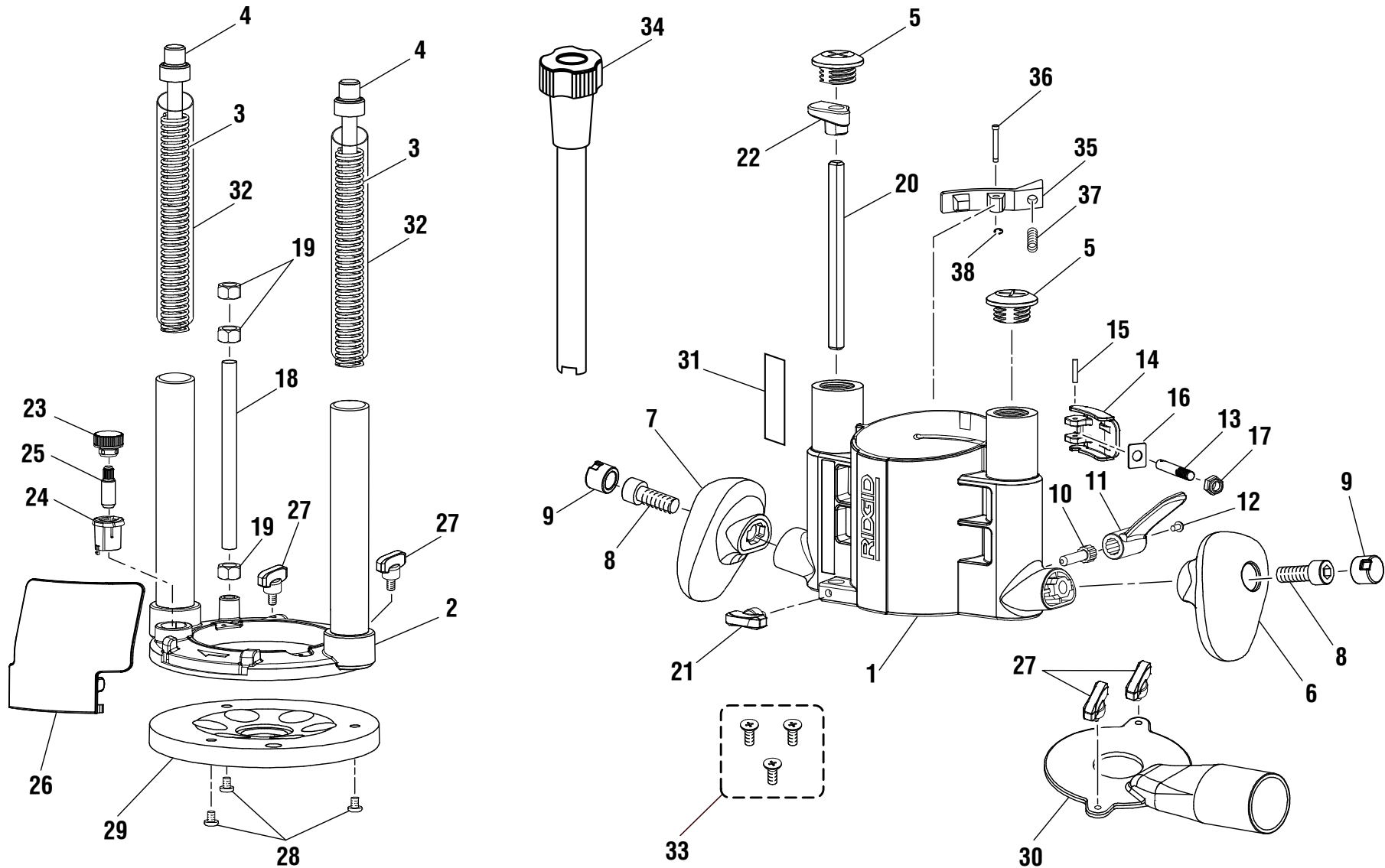

**▲WARNING:** The assembly shown represents an important part of the Double Insulated System. To avoid the possibility of alteration or damage to the System, service should be performed by your nearest authorized service center.

**▲AVERTISSEMENT :** L'ensemble illustré représente une partie importante du système à isolation double. Afin d'éviter la possibilité de modification ou de dommage au système, la réparation ne doit être effectuée que par votre centre de réparation centre commercial autorisé.

**▲ADVERTENCIA:** El conjunto que se ilustra representa una parte importante del Sistema de Aislamiento Doble. Para evitar la posibilidad de alteración o daño del sistema, la reparación debe ser efectuada en su centro de servicio autorizado.



# R29202 Plunge Base Assembly / Base Plongeante / Conjunto de la Base Tipo Émbolo

KEY	P/N	DESCRIPTION	QTY	PIÈCE	RÉF.	DESCRIPTION	QTÉ	REF.	N/P	DESCRIPCIÓN	CANT.
1	201395002	PLUNGE BASE ASSEMBLY.....	1	1	201395002	BASE DE PLONGEUR .....	1	1	201395002	BASE TIPO ÉMBOLO .....	1
2	201392004	PLUNGE BASE w/TUBE ASSEMBLY .....	1	2	201392004	BASE DE PLONGEUR AVEC		2	201392004	BASE TIPO ÉMBOLO CON CONJUNTO	
3	671760002	PLUNGE SPRING .....	2			ENSEMBLE DE TUYUA .....	1			DEL TUBO .....	1
4	513880001	GUIDE PIN .....	2	3	671760002	RESSORT DE PLONGEUR .....	2	3	671760002	RESORTE DE ÉMBOLO.....	2
5	513581001	PLUNGE TOWER CAP.....	2	4	513880001	AXE GUIDE .....	2	4	513880001	PASADOR GUÍA.....	2
6	513347002	RIGHT HANDLE ASSEMBLY .....	1	5	513581001	COUVERCLE DE PLONGEUR.....	2	5	513581001	TAPA DE LA TORRE DEL ÉMBOLO .....	2
7	513348002	LEFT HANDLE ASSEMBLY.....	1	6	513347002	ENSEMBLE DE POIGNÉE DROITE.....	1	6	513347002	CONJUNTO DE MANGO DERECHO.....	1
8	660053003	BOLT (M10 x 28 mm, SOC. HD.).....	2	7	513348002	ENSEMBLE DE POIGNÉE GAUCHE .....	1	7	513348002	CONJUNTO DE MANGO IZQUIERDO.....	1
9	513395001	HANDLE PLUG .....	2	8	660053003	BOULON (M10 x 28 mm,		8	660053003	PERNO (M10 x 28 mm, CAB. HUECA).....	2
10	660427002	SCREW (SPECIAL).....	1			À TÊTE CREUSE).....	2	9	513395001	TAPÓN DEL MANGO .....	2
11	513610001	PLUNGE LOCK LEVER.....	1	9	513395001	BOUCHON DE POIGNÉE .....	2	10	660427002	TORNILLO (ESPECIAL).....	1
12	660284007	SCREW (#6-32 x 1/4 in.).....	1	10	660427002	VIS (SPÉCIALE).....	1	11	513610001	PALANCA DE FIJACIÓN DEL ÉMBOLO.....	1
13	671260002	LEVER PIN .....	1	11	513610001	LEVIER DE VERROUILLAGE		12	660284007	TORNILLO (#6-32 x 1/4 pulg.).....	1
14	201391001	LOCK LEVER ASSEMBLY				DE PLONGÉE.....	1	13	671260002	PASADOR DE LA PALANCA.....	1
		(INCL. KEY NOS. 13 AND 15).....	1	12	660284007	VIS (#6-32 x 1/4 po).....	1	14	201391001	CONJUNTO DE PASADOR DE LA PALANCA	
15	671247001	NEEDLE ROLLER PIN.....	1	13	671260002	AXE DE LEVIER.....	1	15	671247001	(INCL. PZAS. NÚMS. REF. 13 Y 15).....	1
16	631421001	WEAR PLATE .....	1	14	201391001	ENSEMBLE DE AXE DE LEVIER				PASADOR DE ARTICULACIÓN	
17	671243002	LOCK NUT (HEX) .....	1			(INCL. PIÈCES NO. 13 ET 15).....	1			DE LA AGUJA.....	1
18	671275002	DEPTH ADJUSTMENT ROD.....	1	15	671247001	GROUPILLE CYLINDRIQUE À AIGUILLES ..	1	16	631421001	PLACA DE ROZAMIENTO .....	1
19	660163002	HEX NUT (3/8-16) .....	3	16	631421001	PLAQUE D'USURE .....	1	17	671243002	TUERCA DE SEGURIDAD (HEX.) .....	1
20	692301001	DEPTH STOP BAR.....	1	17	671243002	ÉCROU FREIN (HEX.) .....	1	18	671275002	BARRA DE AJUSTE DE PROFUNDIDAD .....	1
21	511129003	RIP GUIDE KNOB .....	1	18	671275002	TIGE DE RÉGLAGE DE PROFONDEUR ....	1	19	660163002	TUERCA HEXAGONAL (3/8-16) .....	3
22	519268001	POINTER.....	1	19	660163002	ÉCROU SIX PANS (3/8-16) .....	3	20	692301001	BARRA TOPE DE PROFUNDIDAD .....	1
23	380851003	DEPTH STOP ADJUSTMENT KNOB .....	1	20	692301001	TIGE DE BUTÉE DE PROFONDEUR .....	1	21	511129003	PERILLA DE GUÍA DE CORTE AL HILO .....	1
24	380852001	DEPTH ADJUSTMENT GAUGE.....	1	21	511129003	BOUTON DE GUIDE LONGITUDINAL .....	1	22	519268001	INDICADOR .....	1
25	670583003	ADJUSTMENT SCREW w/STUD.....	1	22	519268001	POINTEUR .....	1	23	380851003	PERILLA DE AJUSTE DE TOPE	
26	515012001	CHIP SHIELD .....	1	23	380851003	BOUTON DE RÉGLAGE DE LA BUTÉE				DE PROFUNDIDAD.....	1
27	512777001	EDGE GUIDE KNOB .....	4			DE PROFONDEUR.....	1	24	380852001	INDICADOR DE AJUSTE	
28	660136003	SCREW (10-32 x 3/8 in.).....	3	24	380852001	INDICATEUR DE RÉGLAGE				DE LA PROFUNDIDAD .....	1
29	513879001	SUBBASE .....	1			DE LA PROFONDEUR .....	1	25	670583003	TORNILLO/VÁSTAGO DE AJUSTE.....	1
30	513508001	DUST COLLECTOR .....	1	25	670583003	VIS/GOIJON DE RÉGLAGE.....	1	26	515012001	PROTECTOR CONTRA VIRUTAS.....	1
31	940266017	SCALE LABEL.....	1	26	515012001	PARE-COPEAUX.....	1	27	512777001	PERILLA DE LA GUÍA DE BORDES.....	4
32	514481002	TUBE (PVC).....	2	27	512777001	BOUTON DE GUIDE DE CHANT .....	4	28	660136003	TORNILLO (10-32 x 3/8 pulg.).....	3
33	660235013	SCREW (#10-32 x 12 mm, ROUTER		28	660136003	VIS (10-32 x 3/8 po).....	3	29	513879001	SUBBASE .....	1
		ATTACHMENT SCREWS).....	3	29	513879001	SEMELLE .....	1	30	513508001	COLECTOR DE POLVO .....	1
34	200438001	PLUNGE DEPTH ADJUSTMENT KNOB....	1	30	513508001	COLLECTEUR DE POUSSIÈRE.....	1	31	940266017	ETIQUETA DE LA ESCALA .....	1
35	641431001	LATCH LEVER.....	1	31	940266017	ÉTIQUETTE À L'ÉCHELLE .....	1	32	514481002	TUBO (PVC).....	2
36	672435001	PIN .....	1	32	514481002	TUBE (PVC).....	2	33	660235013	TORNILLO (#10-32 x 12 mm, TORNILLOS	
37	690141002	SPRING.....	1	33	660235013	VIS (#10-32 x 12 mm, VIS DE FIXATION				DEL ADITAMENTO DE MESA PARA	
38	671319001	E-RING.....	1			DE TABLE À TOUPIE) .....	3			FRESADORA).....	3
				34	200438001	PROFONDEUR DE PLONGÉE		34	200438001	PERILLA DE AJUSTE DE PROFUNDIDAD	
						BOUTON DE RÉGLAGE .....	1			DEL ÉMBOLO .....	1
				35	641431001	LEVIER DE LOQUET .....	1	35	641431001	PALANCA DE PICAPORTE.....	1
				36	672435001	AXE .....	1	36	672435001	PASADOR .....	1
				37	690141002	RESSORT.....	1	37	690141002	RESORTE.....	1
				38	671319001	CLIP EN E .....	1	38	671319001	ANILLO EN "E" .....	1



# R2901 Motor Assembly / Moteur / Conjunto del Motor

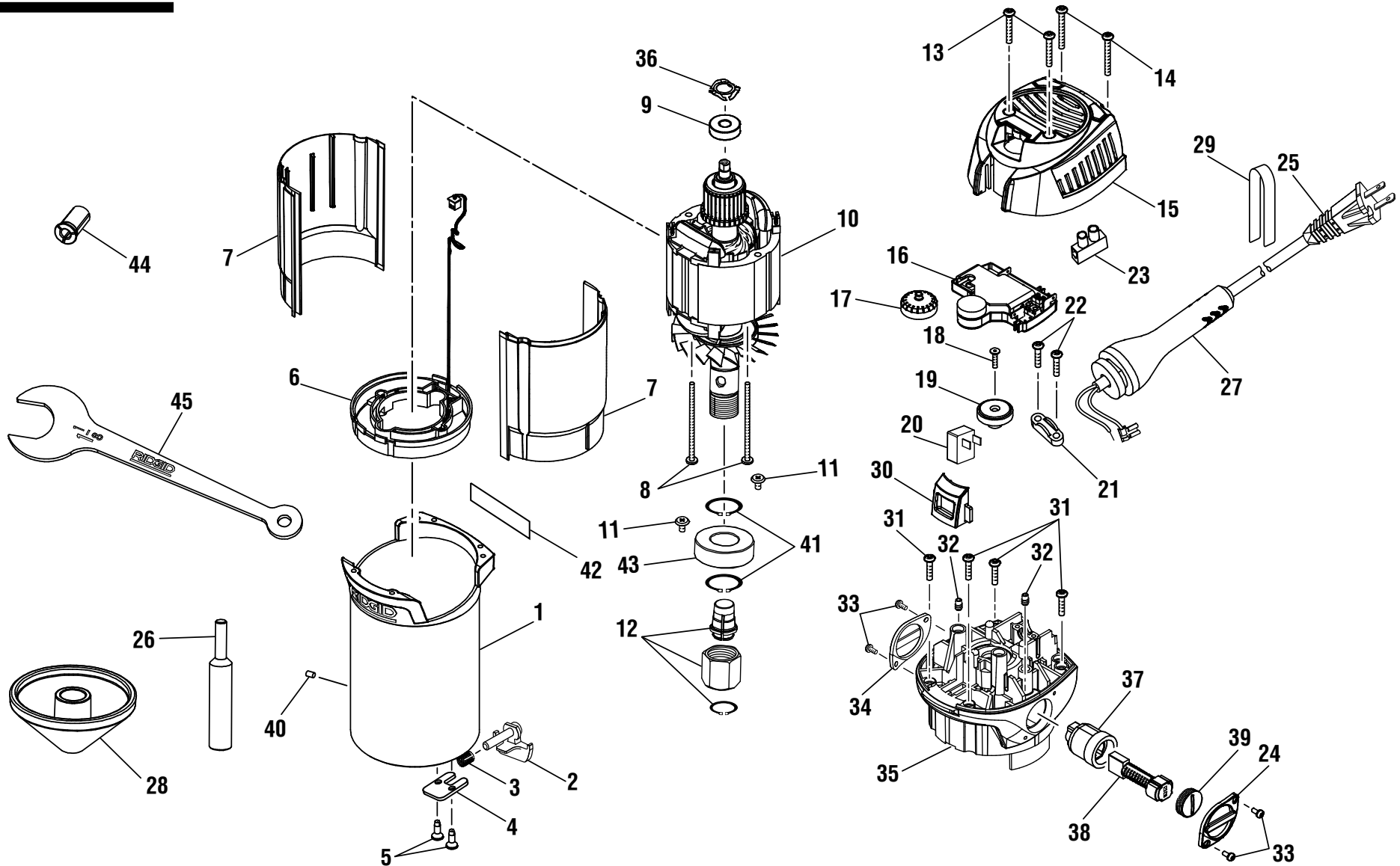

**▲WARNING:** The assembly shown represents an important part of the Double Insulated System. To avoid the possibility of alteration or damage to the System, service should be performed by your nearest authorized service center.

**▲AVERTISSEMENT :** L'ensemble illustré représente une partie importante du système à isolation double. Afin d'éviter la possibilité de modification ou de dommage au système, la réparation ne doit être effectuée que par votre centre de réparation centre commercial autorisé.

**▲ADVERTENCIA:** El conjunto que se ilustra representa una parte importante del Sistema de Aislamiento Doble. Para evitar la posibilidad de alteración o daño del sistema, la reparación debe ser efectuada en su centro de servicio autorizado.



# R2901 Motor Assembly

KEY	P/N	DESCRIPTION	QTY	KEY	P/N	DESCRIPTION	QTY	KEY	P/N	DESCRIPTION	QTY
1	201387002	MOTOR HOUSING ASSEMBLY.....	1	17	340338001	VARIABLE SPEED DIAL.....	1	34	513397001	BRUSH CAP RETAINER (LH).....	1
	641375003	MOTOR HOUSING .....	1	18	660423005	SCREW (M3.5 x 14 mm).....	1	35	519273003	BEARING BRACKET w/INSERT .....	1
2	515210002	SHAFT LOCK BUTTON .....	1	19	301303001	MAGNET .....	1	36	671862002	LOADING SPRING.....	1
3	690141003	SHAFT LOCK SPRING.....	1	20	760385003	SWITCH .....	1	37	301035001	BRUSH HOLDER ASSEMBLY .....	2
4	631966002	COVER PLATE .....	1	21	590924001	CORD CLAMP .....	1	38	301036001	BRUSH ASSEMBLY .....	2
5	661039001	SCREW (#8-32 x 3/8 in.).....	2	22	660372001	SCREW (#6-19 HI-LO PH T15).....	2	39	512010001	BRUSH CAP .....	2
6	290139020	LED ASSEMBLY.....	1	23	690331004	TERMINAL BLOCK.....	1	40	671881001	PIN .....	1
7	519267001	INSULATING SLEEVE .....	2	24	513400001	BRUSH CAP RETAINER (RH) .....	1	41	680370001	RETAINING RING.....	2
8	660237009	SCREW (M0.170 in. x 2.625 in.).....	2	25	201390001	POWER CORD ASSEMBLY (INCL. KEY NOS. 26-29).....	1	42	940976444	DATA LABEL .....	1
9	680966001	BALL BEARING (NTN #608LLUC3/1E) ...	1	26	671675001	CENTERING TOOL PIN .....	1	43	680733003	BALL BEARING (6004W) .....	1
10	290332001	MOTOR ASSEMBLY (INCL. KEY NOS. 9, 41, AND 43).....	1	27	561365001	BEND RELIEF .....	1	44	670344002	COLLET ADAPTOR (1/4 in.).....	1
11	660324002	SCREW (#10-32 x 3/8 in., WAFER HD.)...2		28	513095001	CENTERING TOOL CONE.....	1	45	670346004	WRENCH .....	1
12	201389001	COLLET ASSEMBLY (1/2 in.).....	1	29	940299942	CORD TAG .....	1	<b>NOT SHOWN:</b>			
13	660436006	SCREW (M4 x 25 mm, PAN HD.).....	2	30	513086002	SWITCH ACTUATOR .....	1	901311002	TOOL BAG.....	1	
14	660437004	SCREW (M4 x 32 mm, PAN HD.).....	2	31	660212053	SCREW (M4 x 16 mm).....	4	987000684	OPERATOR'S MANUAL.....	1	
15	340084002	TOP CAP.....	1	32	660067001	SCREW (#8-16 x 1/4 in.).....	2	1-16-13 (REV:07)			
16	280013219	CIRCUIT BOARD ASSEMBLY.....	1	33	660438002	SCREW (M3 x 8 mm, PAN HD.).....	4				