

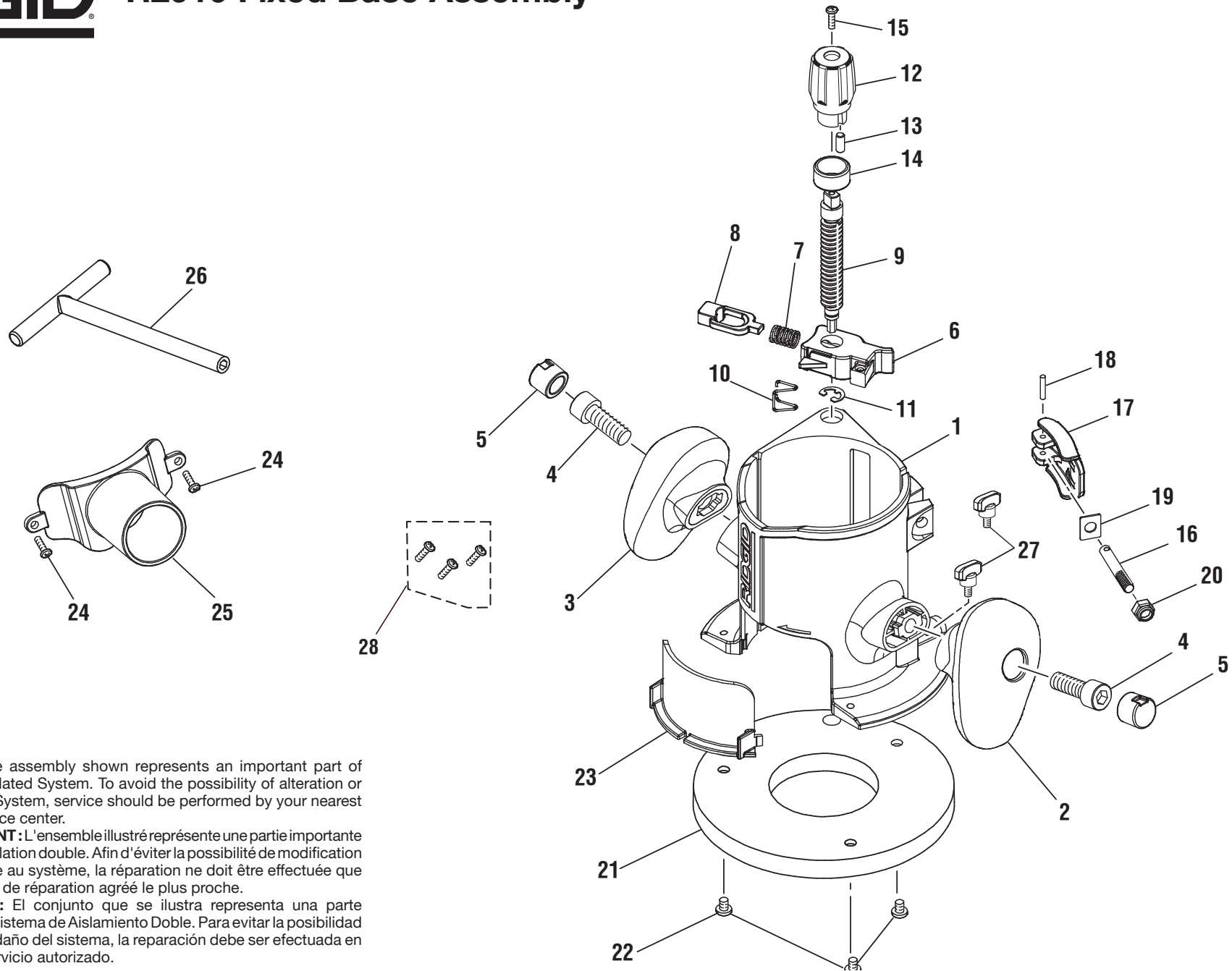

# R2910 Fixed Base Assembly



**⚠ WARNING:** The assembly shown represents an important part of the Double Insulated System. To avoid the possibility of alteration or damage to the System, service should be performed by your nearest authorized service center.

**⚠ AVERTISSEMENT :** L'ensemble illustré représente une partie importante du système à isolation double. Afin d'éviter la possibilité de modification ou de dommage au système, la réparation ne doit être effectuée que par votre centre de réparation agréé le plus proche.

**⚠ ADVERTENCIA:** El conjunto que se ilustra representa una parte importante del Sistema de Aislamiento Doble. Para evitar la posibilidad de alteración o daño del sistema, la reparación debe ser efectuada en su centro de servicio autorizado.



# R2910 Fixed Base Assembly/R2910 Base Fixe/R2910 Conjunto de la Base Fija

KEY	P/N	DESCRIPTION	QTY	PIÈCE	RÉF.	DESCRIPTION	QTÉ	REF.	N/P	DESCRIPCIÓN	CANT.
1	640925001	ROUTER BASE .....	1	1	640925001	BASE DE TOUPIE .....	1	1	640925001	BASE DE LA FRESADORA .....	1
2	513347001	RIGHT HANDLE .....	1	2	513347001	POIGNÉE DROITE .....	1	2	513347001	MANGO DERECHO .....	1
3	513348001	LEFT HANDLE .....	1	3	513348001	POIGNÉE GAUCHE .....	1	3	513348001	MANGO IZQUIERDO .....	1
4	660053003	BOLT (M10 x 28 mm SOC. HD.) .....	2	4	660053003	BOULON (M10 x 28 mm à tête creuse.) .....	2	4	660053003	PERNO (M10 x 28 mm CAB. HUECA) .....	2
5	513395001	HANDLE PLUG .....	2	5	513395001	BOUCHON DE POIGNÉE .....	2	5	513395001	TAPÓN DEL MANGO .....	2
6	640963001	ADJUSTMENT BAR .....	1	6	640963001	TIGE DE RÉGLAGE .....	1	6	640963001	BARRA DE AJUSTE .....	1
7	671758001	COMPRESSION SPRING .....	1	7	671758001	RESSORT .....	1	7	671758001	RESORTE .....	1
8	513396001	ADJUSTMENT BUTTON HOUSING .....	1	8	513396001	LOGEMENT DU BOUTON DE RÉGLAGE .....	1	8	513396001	ALOJAMIENTO DEL BOTÓN DE AJUSTE .....	1
9	671757001	HEIGHT ADJUSTMENT SCREW .....	1	9	671757001	VIS DE RÉGLAGE DE HAUTEUR .....	1	9	671757001	TORNILLO DE AJUSTE DE ALTURA .....	1
10	671759001	TORSION SPRING .....	1	10	671759001	RESSORT DE TORSION .....	1	10	671759001	RESORTE DE TORSIÓN .....	1
11	671797001	E-RING .....	1	11	671797001	CLIP EN E .....	1	11	671797001	ANILLO EN "E" .....	1
12	513093001	DEPTH ADJUSTMENT KNOB .....	1	12	513093001	BOUTON DE RÉGLAGE DE PROFONDEUR .....	1	12	513093001	PERILLA DE AJUSTE DE PROFUNDIDAD .....	1
13	570334001	RUBBER PLUG .....	1	13	570334001	BOUCHON EN CAOUTCHOUC .....	1	13	570334001	TAPÓN DE CAUCHO .....	1
14	340092001	ZERO RESET RING .....	1	14	340092001	BAGUE DE REMISE À ZÉRO .....	1	14	340092001	ANILLO DE AJUSTE A CERO .....	1
15	660440001	SCREW (M3.5 x 12 mm) .....	1	15	660440001	VIS (M3,5 x 12 mm) .....	1	15	660440001	TORNILLO (M3,5 x 12 mm) .....	1
16	671260001	LEVER PIN .....	1	16	671260001	AXE DE LEVIER .....	1	16	671260001	PASADOR DE LA PALANCA .....	1
17	200276009	LOCK LEVER .....	1	17	200276009	LEVIER DE VERROUILLAGE .....	1	17	200276009	PALANCA DE FIJACIÓN .....	1
18	671247001	ROLL PIN .....	1	18	671247001	GOUILLE CYLINDRIQUE .....	1	18	671247001	PASADOR DE ARTICULACIÓN .....	1
19	631421001	WEAR PLATE .....	1	19	631421001	PLAQUE D'USURE .....	1	19	631421001	PLACA DE ROZAMIENTO .....	1
20	671243001	STOP NUT .....	1	20	671243001	ÉCROU DE BLOCAGE .....	1	20	671243001	TUERCA DE SEGURIDAD .....	1
21	513087001	SUBBASE .....	1	21	513087001	SEMELLE .....	1	21	513087001	SUBBASE .....	1
22	660136002	SCREW (10-32 x 3/8 in.) .....	3	22	660136002	VIS (10-32 x 9,5 mm [3/8 po]) .....	3	22	660136002	TORNILLO (10-32 x 9,5 mm [3/8 pulg.]) .....	3
23	513094001	CHIP SHIELD .....	1	23	513094001	PARE-COPEAUX .....	1	23	513094001	PROTECTOR CONTRA VIRUTAS .....	1
24	660284004	VACUUM ADAPTOR SCREW (6-32 x 3/8 in. PAN HD.) .....	2	24	660284004	VIS DE ADAPTATEURS DE SAC (6-32 x 9,5 MM [3/8 PO] TÊTE BOMBÉE) .....	2	24	660284004	TORNILLO DE ADAPTADOR PARA ASPIRADORA (6-32 x 3/8 pulg. PAN HD.) .....	2
25	513349001	VACUUM ADAPTOR .....	1	25	513349001	ADAPTATEURS DE SAC .....	1	25	513349001	ADAPTADOR PARA ASPIRADORA .....	1
26	513667001	T-HANDLE WRENCH .....	1	26	513667001	CLÉ EN T .....	1	26	513667001	LLAVE DE MANGO EN "T" .....	1
27	512777001	GUIDE ADJUSTMENT KNOB .....	2	27	512777001	BOUTON DE RÉGLAGE DE GUIDE .....	2	27	512777001	PERILLA DE AJUSTE DE LA GUÍA .....	2
28	660235010	ROUTER TABLE ATTACHMENT SCREWS .....	3	28	660235010	VIS DE FIXATION DE TABLE À TOUPIE .....	3	28	660235010	TORNILLOS DEL ADITAMENTO DE MESA PARA FRESADORA .....	3



# R2920 Plunge Base Assembly

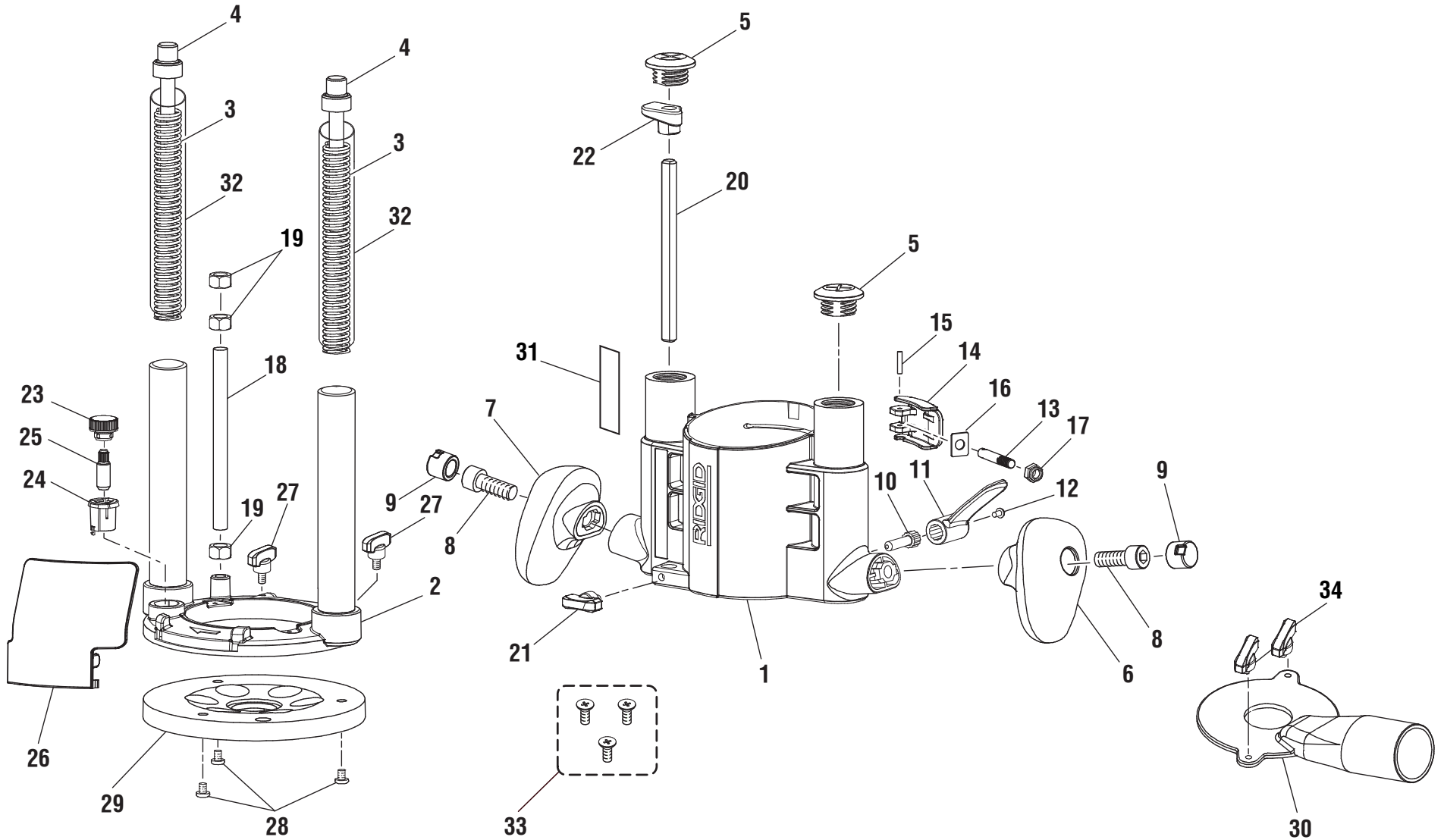

**▲WARNING:** The assembly shown represents an important part of the Double Insulated System. To avoid the possibility of alteration or damage to the System, service should be performed by your nearest authorized service center.

**▲AVERTISSEMENT :** L'ensemble illustré représente une partie importante du système à isolation double. Afin d'éviter la possibilité de modification ou de dommage au système, la réparation ne doit être effectuée que par votre centre de réparation centre commercial autorisé.

**▲ADVERTENCIA:** El conjunto que se ilustra representa una parte importante del Sistema de Aislamiento Doble. Para evitar la posibilidad de alteración o daño del sistema, la reparación debe ser efectuada en su centro de servicio autorizado.



# R2920 Plunge Base Assembly/R29201 Base Plongeante/R29201 Conjunto de la Base Tipo Émbolo

KEY	P/N	DESCRIPTION	QTY	PIÈCE	RÉF.	DESCRIPTION	QTÉ	REF.	N/P	DESCRIPCIÓN	CANT.
1	200265002	PLUNGE FRAME ASSEMBLY.....	1	1	200265002	BÂTI DE PLONGEUR.....	1	1	200265002	BASTIDOR TIPO ÉMBOLO.....	1
2	200242004	PLUNGE BASE ASSEMBLY.....	1	2	200242004	BASE DE PLONGEUR.....	1	2	200242004	BASE TIPO ÉMBOLO.....	1
3	671760001	PLUNGE SPRING.....	2	3	671760001	RESSORT DE PLONGEUR.....	2	3	671760001	RESORTE DE ÉMBOLO.....	2
4	513880001	GUIDE PIN.....	2	4	513880001	AXE GUIDE.....	2	4	513880001	PASADOR GUÍA.....	2
5	513581001	PLUNGE TOWER CAP.....	2	5	513581001	COUVERCLE DE PLONGEUR.....	2	5	513581001	TAPA DE LA TORRE DEL ÉMBOLO.....	2
6	513347001	RIGHT HANDLE.....	1	6	513347001	POIGNÉE DROITE.....	1	6	513347001	MANGO DERECHO.....	1
7	513348001	LEFT HANDLE.....	1	7	513348001	POIGNÉE GAUCHE.....	1	7	513348001	MANGO IZQUIERDO.....	1
8	660053003	BOLT (M10 x 28 mm SOC. HD.).....	2	8	660053003	BOULON (M10 x 28 mm À TÊTE CREUSE).....	2	8	660053003	PERNO (M10 x 28 mm CAB. HUECA) ..	2
9	513395001	PLUG HANDLE.....	2	9	513395001	BOUCHON DE POIGNÉE.....	2	9	513395001	TAPÓN DEL MANGO.....	2
10	660427002	SCREW (M8 x 1-1/8 in. LH.).....	1	9	513395001	BOUCHON DE POIGNÉE.....	2	10	660427002	TORNILLO (M8 x 28,6 mm [1 1/8 pulg.] IZQ.).....	1
11	513610001	PLUNGE LOCK LEVER.....	1	10	660427002	VIS (M8 x 28,6 mm [1 1/8 po] LH.).....	1	11	513610001	PALANCA DE FIJACIÓN DEL ÉMBOLO	1
12	660284003	SCREW (6-32 x 1/4 in.).....	1	11	513610001	LEVIER DE VERROUILLAGE DE PLONGÉE.....	1	12	660284003	TORNILLO (6-32 x 6,4 mm [1/4 pulg.]..	1
13	671260001	LEVER PIN.....	1	12	660284003	VIS (6-32 x 6 mm [1/4 po]).....	1	13	671260001	PASADOR DE LA PALANCA.....	1
14	200276010	LOCK LEVER.....	1	12	660284003	VIS (6-32 x 6 mm [1/4 po]).....	1	13	671260001	PASADOR DE LA PALANCA.....	1
15	671247001	ROLL PIN.....	1	13	671260001	AXE DE LEVIER.....	1	14	200276010	PALANCA DE FIJACIÓN.....	1
16	631421001	WEAR PLATE.....	1	14	200276010	LEVIER DE VERROUILLAGE.....	1	15	671247001	PASADOR DE ARTICULACIÓN.....	1
17	671243001	STOP NUT.....	1	15	671247001	GOUPILLE CYLINDRIQUE.....	1	16	631421001	PLACA DE ROZAMIENTO.....	1
18	671275001	DEPTH ADJUSTMENT ROD.....	1	16	631421001	PLAQUE D'USURE.....	1	17	671243001	TUERCA DE SEGURIDAD.....	1
19	660163002	HEX NUT (3/8-16).....	3	17	671243001	ÉCROU DE BLOCAGE.....	1	18	671275001	BARRA DE AJUSTE DE PROFUNDIDAD1	1
20	620446001	ADJUSTMENT BAR.....	1	18	671275001	TIGE DE RÉGLAGE DE PROFONDEUR 1	1	19	660163002	TUERCA HEXAGONAL (3/8-16).....	3
21	511129001	ADJUSTMENT BAR KNOB.....	1	19	660163002	ÉCROU SIX PANS (3/8-16).....	3	20	620446001	BARRA DE AJUSTE.....	1
22	513449001	DEPTH INDICATOR.....	1	20	620446001	BARRE DE RÉGLAGE.....	1	21	511129001	PERILLA DE LA BARRA DE AJUSTE.....	1
23	380851003	PLUNGE DEPTH ADJUSTMENT KNOB.....	1	21	511129001	BOUTON DE BARRE DE RÉGLAGE.....	1	22	513449001	INDICADOR DE PROFUNDIDAD.....	1
24	380852001	DEPTH ADJUSTMENT GAUGE.....	1	22	513449001	JAUGE DE PROFONDEUR.....	1	23	380851003	PERILLA DE AJUSTE DE PROFUNDIDAD DEL ÉMBOLO.....	1
25	670583003	ADJUSTMENT SCREW/STUD.....	1	23	380851003	PROFONDEUR DE PLONGÉE BOUTON DE RÉGLAGE.....	1	24	380852001	CALIBRE DE AJUSTE DE PROFUNDIDAD.....	1
26	515012001	CHIP SHIELD.....	1	24	380852001	JAUGE DE RÉGLAGE DE PROFONDEUR.....	1	25	670583003	TORNILLO/VÁSTAGO DE AJUSTE.....	1
27	512777001	GUIDE ADJUST KNOBS.....	2	25	670583003	VIS/GOIJON DE RÉGLAGE.....	1	26	515012001	PROTECTOR CONTRA VIRUTAS.....	1
28	660136002	SCREW (10-32 x 3/8 in.).....	3	25	670583003	VIS/GOIJON DE RÉGLAGE.....	1	26	515012001	PROTECTOR CONTRA VIRUTAS.....	1
29	513879001	SUB BASE.....	1	26	515012001	PARE - COPEAUX.....	1	27	512777001	PERILLAS DE LA BASE.....	2
30	513508001	VACUUM ADAPTOR.....	1	27	512777001	BOUTONS DE LA BASE.....	2	28	660136002	TORNILLO (10-32 x 9,5 mm [3/8 pulg.].....	3
31	940299757	SCALE LABEL.....	1	28	660136002	VIS (10-32 x 9,5 mm [3/8 po]).....	3	29	513879001	SUBBASE.....	1
32	514481001	TUBE (PVC).....	2	29	513879001	SEMELLE.....	1	29	513879001	ADAPTADOR PARA CAPTACIÓN DE POLVO.....	1
33	660235010	ROUTER TABLE ATTACHMENT SCREWS.....	3	30	513508001	ADAPTATEUR DE SAC À POUSSIÈRE..	1	30	513508001	ETIQUETA DE RÉGLE.....	1
34	512777001	VACUUM ADAPTER SCREW.....	2	31	940299757	PLAQUETTE RÈGLE.....	1	31	940299757	TUBO (PVC).....	2
				32	514481001	TUBE (PVC).....	2	32	514481001	TORNILLOS DEL ADITAMENTO DE MESA PARA FRESADORA.....	3
				33	660235010	VIS DE FIXATION DE TABLE À TOUPIE.	3	33	660235010	TORNILLOS DEL ADAPTADOR DE LA ASPIRADORA.....	2
				34	512777001	VIS DE ADAPTATEUR D'ASPIRATION... 2	2	34	512777001		



# R2900 Motor Assembly

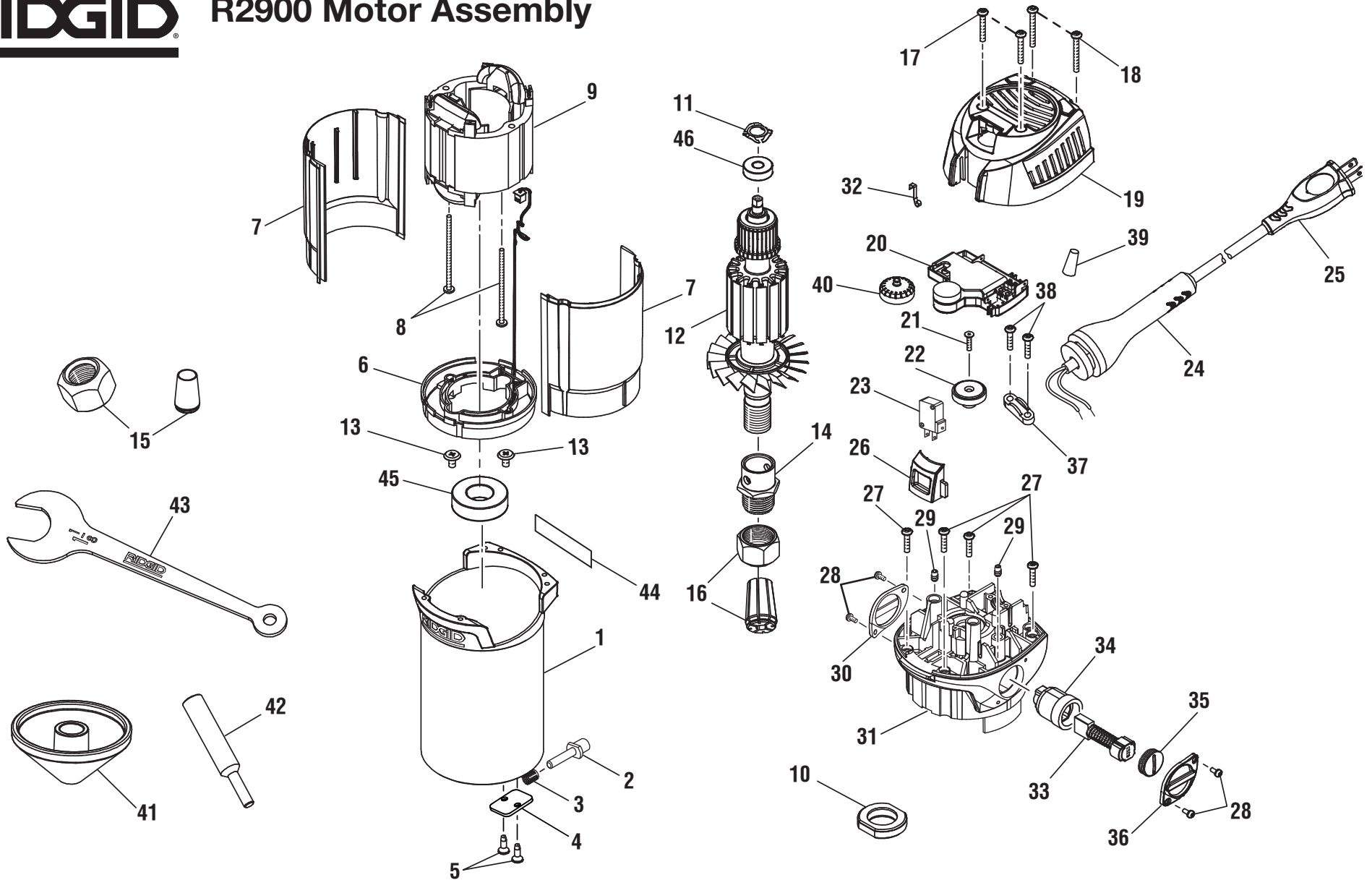

**▲WARNING:** The assembly shown represents an important part of the Double Insulated System. To avoid the possibility of alteration or damage to the System, service should be performed by your nearest authorized service center.

**▲AVERTISSEMENT :** L'ensemble illustré représente une partie importante du système à isolation double. Afin d'éviter la possibilité de modification ou de dommage au système, la réparation ne doit être effectuée que par votre centre de réparation commerciale autorisé.

**▲ADVERTENCIA:** El conjunto que se ilustra representa una parte importante del Sistema de Aislamiento Doble. Para evitar la posibilidad de alteración o daño del sistema, la reparación debe ser efectuada en su centro de servicio autorizado.



# R2900 Motor Assembly

KEY	P/N	DESCRIPTION	QTY	KEY	P/N	DESCRIPTION	QTY	KEY	P/N	DESCRIPTION	QTY
1	200058006	MOTOR HOUSING .....	1	17	660437003	SCREW (M4 x 25 mm PAN HD.).....	2	33	301036001	BRUSH ASSEMBLY .....	2
2	671880001	SHAFT LOCK BUTTON .....	1	18	660437002	SCREW (M4 x 32 mm PAN HD.).....	2	34	301035001	BRUSH HOLDER ASSEMBLY .....	2
3	690141001	SHAFT LOCK SPRING.....	1	19	340084001	TOP CAP.....	1	35	512010001	BRUSH CAP .....	2
4	630005001	COVER PLATE .....	1	20	280013219	CIRCUIT BOARD ASSEMBLY.....	1	36	513400001	BRUSH CAP RETAINER (RH) .....	1
5	660325001	SCREW (8-32 x 3/8 in.).....	2	21	660423002	SCREW (M3.5 x 14 mm FLAT HD.).....	1	37	590924001	CORD CLAMP .....	1
6	290139020	LED TRAY ASSEMBLY.....	1	22	301303001	ROTOR MAGNET.....	1	38	660372001	SCREW (#6-19 x 5/8 in. PAN HD.).....	2
7	513082001	INSULATING SLEEVE .....	2	23	760677003	SWITCH .....	1	39	870126002	WIRE NUT .....	1
8	660103002	SCREW (8-10 x 2 5/8 in.).....	2	24	561365001	BEND RELIEF .....	1	40	340338001	VARIABLE SPEED DIAL.....	1
9	740744001	FIELD .....	1	25	290086035	POWER CORD.....	1	41	513095001	CENTERING TOOL CONE .....	1
10	671733001	BEARING INSERT.....	1	26	513086001	SWITCH ACTUATOR .....	1	42	671675001	CENTERING TOOL PIN .....	1
11	671862001	LOADING SPRING.....	1	27	660185003	SCREW (M4 x 16 mm PAN HD.).....	4	43	671674001	WRENCH .....	2
12	200439001	ARMATURE (INC. KEY 47).....	1	28	660438001	SCREW (M3 x 6 mm PAN HD.).....	4	44	940301032	DATA LABEL .....	1
13	660324001	SCREW (10-32 x 3/8 in. WAFER HEAD).....	2	29	660067001	SCREW (8-16 x 1/4 in. TORX).....	2	45	680733002	BALL BEARING (6004 VV) .....	1
14	671876001	BEARING RETAINER .....	1	30	513397001	BRUSH CAP RETAINER (LH).....	1	46	680966001	BALL BEARING.....	1
15	200150002	COLLET ASSEMBLY (1/4 in.).....	1	31	200440001	BEARING HOUSING ASSEMBLY (INC. KEY 10).....	1	<b>NOT SHOWN:</b>			
16	200150003	COLLET ASSEMBLY (1/2 in.).....	1	32	671845001	DETENT SPRING.....	1	983000786	OPERATOR'S MANUAL.....	1	