

⚠ DANGER: Do not use oxygen, combustible gases, or bottled gases as a power source for this tool. The tool will explode and cause death or serious injury.

⚠ DANGER : Ne pas utiliser de l'oxygène ou des gaz combustibles ou en bouteille pour alimenter l'outil. L'outil exploserait, causant des blessures graves ou mortelles.

⚠ PELIGRO: No utilice oxígeno, gases combustibles ni gases embotellados como fuente de energía para esta herramienta. La herramienta explotará y causará la muerte o lesiones serias.

⚠ WARNING: Disconnect the tool from the air supply before performing maintenance. Failure to do so could result in serious personal injury.

⚠ AVERTISSEMENT : Débrancher l'outil de la source d'air avant tout entretien. Ne pas prendre cette précaution peut entraîner des blessures graves.

⚠ ADVERTENCIA: Desconecte la herramienta del suministro de aire antes de efectuar tareas de mantenimiento. La inobservancia de esta advertencia puede causar lesiones serias.



R213BNE BRAD NAILER

KEY	P/N	DESCRIPTION	QTY	KEY	P/N	DESCRIPTION	QTY
1	079071001046	Screw (M4 x 20 mm, Soc Hd.)	4	20	079001001033	O-Ring (7.5 x 1.5)	1
2	079074001001	Cap	1	21	079074001018	Trigger Valve Head	1
3	079074001002	Cushion	1	22	079001001022	Spring	1
4	079001001005	Compression Spring	1	23	079071001029	O-Ring (2.5 x 1.5)	1
5	079074001704	Upper Head Valve Assembly	1	24	079001001023	Plunger	1
6	079074001705	Lower Head Valve Assembly	1	25	079001001025	O-Ring (2.5 x 1.5)	1
7	079074001006	Gasket	1	26	079074001019	O-Ring (11 x 1.6)	1
8	079073001703	Driver Assembly (Incl. Key Nos. 9-11)	1	27	079074001020	Plunger Cap	1
9	079001001008	Piston Ring	1	28	079001001030	Spring	1
10	079001001010	O-Ring (23 x 2)	1	29	079074001023	Trigger	1
11	079073001001	Driver Unit	1	30	079074001707	Workpiece Contact Assembly	1
12	079001001011	Collar	1	31	079007001083	Screw (M4 x 4 mm)	1
13	079073001002	Cylinder	1	32	079073001019	Workpiece Contact (B)	1
14	079001001013	O-Ring (32 x 2)	1	33	079001001051	E-Ring	1
15	079001001015	Cylinder Spacer	1	34	079007001084	Workpiece Contact (C)	1
16	079001001016	O-Ring (47.5 x 2)	1	35	079007001093	No Mar Pad	1
17	079001001014	Cylinder Ring	1	NOT SHOWN:			
18	079001001017	Bumper	1	988000610	Operator's Manual	1	
19	079074001706	Trigger Valve Assembly (Incl. Key Nos. 20-27)	1	6-13-13			
				(REV: 01)			

RIDGID® R213BNE

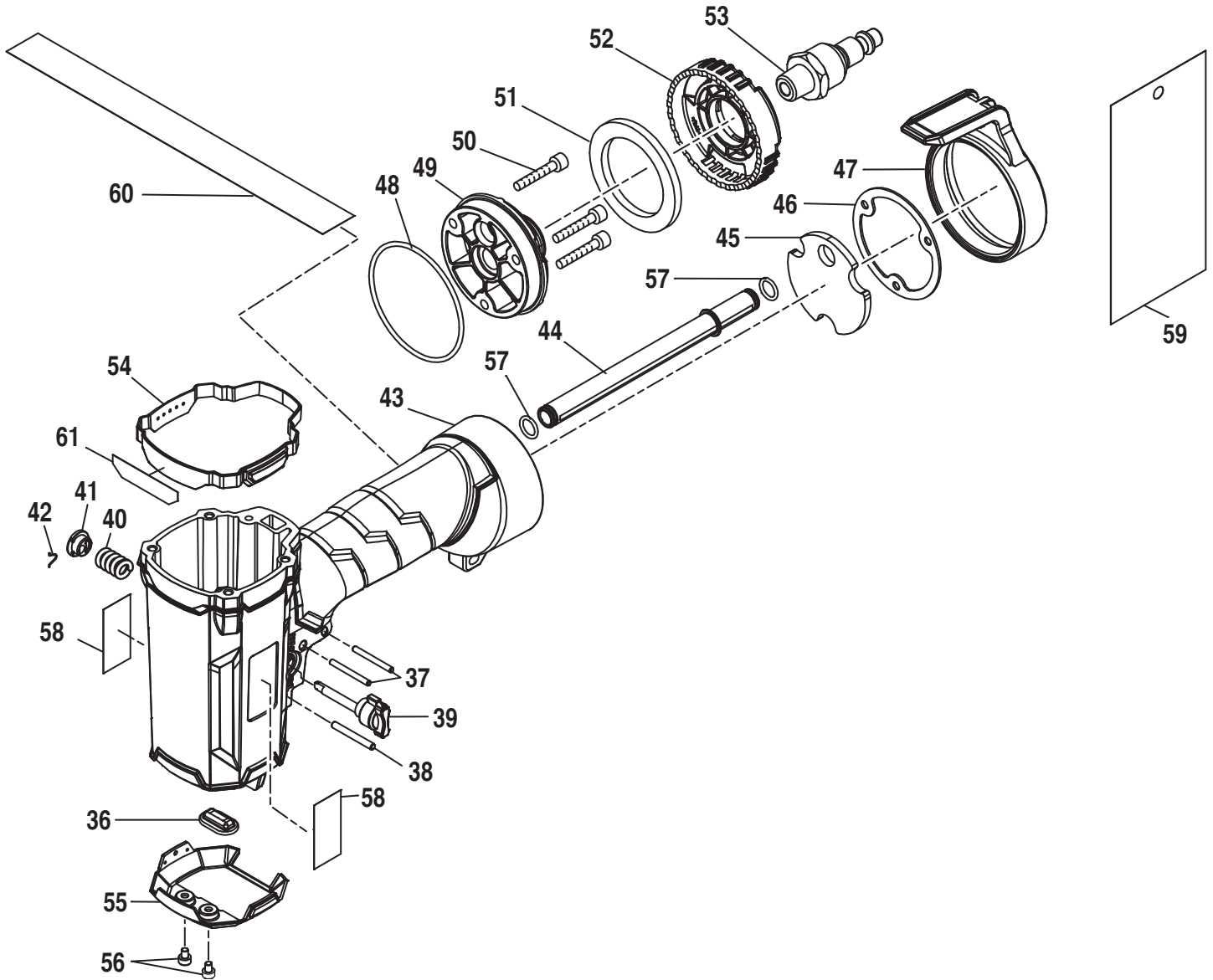

⚠ DANGER: Do not use oxygen, combustible gases, or bottled gases as a power source for this tool. The tool will explode and cause death or serious injury.

⚠ DANGER : Ne pas utiliser de l'oxygène ou des gaz combustibles ou en bouteille pour alimenter l'outil. L'outil exploserait, causant des blessures graves ou mortelles.

⚠ PELIGRO: No utilice oxígeno, gases combustibles ni gases embotellados como fuente de energía para esta herramienta. La herramienta explotará y causará la muerte o lesiones serias.

⚠ WARNING: Disconnect the tool from the air supply before performing maintenance. Failure to do so could result in serious personal injury.

⚠ AVERTISSEMENT : Débrancher l'outil de la source d'air avant tout entretien. Ne pas prendre cette précaution peut entraîner des blessures graves.

⚠ ADVERTENCIA: Desconecte la herramienta del suministro de aire antes de efectuar tareas de mantenimiento. La inobservancia de esta advertencia puede causar lesiones serias.

RIDGID® R213BNE BRAD NAILER

KEY	P/N	DESCRIPTION	QTY	KEY	P/N	DESCRIPTION	QTY
36	079073001003	Joint Guide	1	49	079074001013	End Cap (NPT 1/4 in.-18).....	1
37	079074001021	Spring Pin (D2.5 x 24)	2	50	079001001074	Screw (M4 x 22 mm, Soc. Hd.).....	3
38	079074001022	Spring Pin (D3 x 25)	1	51	079074001014	Muffler	1
39	079071001033	Mode Selector Switch	1	52	079074001015	Exhaust Diverter	1
40	079071001034	Spring	1	53	079001001046	Air Plug (NPT 3/8 in. -18)	1
41	079071001035	Mode Selector Button.....	1	54	079074001016	Protection Ring (Upper)	1
42	079071001036	U-Clip.....	1	55	079074001017	Protection Ring (Lower)	1
43	079074001008	Tool Body Unit	1	56	079071001049	Screw (M3 x 4 mm, Soc. Hd.).....	2
44	079001001034	Exhaust Tube	1	57	079001001033	O-Ring (7.5 x 1.5).....	2
45	079074001009	Filter	1	58	079023003901	Logo Label	2
46	079074001010	Gasket.....	1	59	079028006903	Warning Hang Tag	1
47	079074001011	Belt Hook	1	60	079005004908	Trigger Wrap Label.....	1
48	079074001012	O-Ring (52.5 x 2).....	1	61	079023003905	Fasten Edge Label.....	1

RIDGID® R213 CLOUEUSE À PARQUET

CLÉ	RÉF.	DESCRIPTION	QTÉ	CLÉ	RÉF.	DESCRIPTION	QTÉ
36	079073001003	Guide d'assemblage.....	1	49	079074001013	Capuchon d'extrémité (NPT 1/4 po-18)	1
37	079074001021	Goupille à ressort (D2,5 x 24)	2	50	079001001074	Vis (M4 x 22 mm, tête creuse)	3
38	079074001022	Goupille à ressort (D3 x 25)	1	51	079074001014	Silencieux.....	1
39	079071001033	Cadran de sélection du mode	1	52	079074001015	Évacuation d'aiguillage	1
40	079071001034	Ressort.....	1	53	079001001046	Bouchon aire (NPT 3/8 po -18).....	1
41	079071001035	Bouton selecteur de mode	1	54	079074001016	Bague de protection (supérieur)	1
42	079071001036	Clip en U	1	55	079074001017	Bague de protection (inférieur)	1
43	079074001008	Dispositif du corps de l'outil.....	1	56	079071001049	Vis (M3 x 4 mm, tête creuse)	2
44	079001001034	Tuyau d'échappement	1	57	079001001033	Joint torique en O (7,5 x 1,5)	2
45	079074001009	Filtre	1	58	079023003901	Étiquette de Logo	2
46	079074001010	Joint	1	59	079028006903	Étiquette attachée d'avertissement	1
47	079074001011	Crochet de courroie	1	60	079005004908	Étiquette de ressort de poussoir.....	1
48	079074001012	Joint torique en O (52,5 x 2)	1	61	079023003905	Étiquette de « Fasten Edge »	1

RIDGID® R213BNE CLAVADORA DE PUNTILLAS

REF.	N/P	DESCRIPCIÓN	CANT.	REF.	N/P	DESCRIPCIÓN	CANT.
36	079073001003	Guía de juntas.....	1	49	079074001013	Tapón para el aire (NPT 3/8 pulg. -18).....	1
37	079074001021	Pasador de resorte (D2,5 x 24)	2	50	079001001074	Tornillo (M4 x 22 mm, cab. hueca)...	3
38	079074001022	Pasador de resorte (D3 x 25)	1	51	079074001014	Silenciador	1
39	079071001033	Disco de selección de modo	1	52	079074001015	Desviadora de escape	1
40	079071001034	Resorte.....	1	53	079001001046	Tapa extremo (NPT 1/4 pulg.-18).....	1
41	079071001035	Botón selector de modo	1	54	079074001016	Anillo de protección (superior)	1
42	079071001036	Sujetador en "U"	1	55	079074001017	Anillo de protección (inferior)	1
43	079074001008	Armazón de la herramienta la unidad	1	56	079071001049	Tornillo (M3 x 4 mm, cab. hueca).....	2
44	079001001034	Tubo de escape.....	1	57	079001001033	Anillo en "O" (7,5 x 1,5).....	2
45	079074001009	Filtro	1	58	079023003901	Etiqueta del logotipo	2
46	079074001010	Junta	1	59	079028006903	Etiqueta colgante de advertencia ...	1
47	079074001011	Gancho de la correa.....	1	60	079005004908	Etiqueta del gatillo	1
48	079074001012	Anillo en "O" (52,5 x 2)	1	61	079023003905	Etiqueta de "Fasten Edge"	1

RIDGID® R213BNE

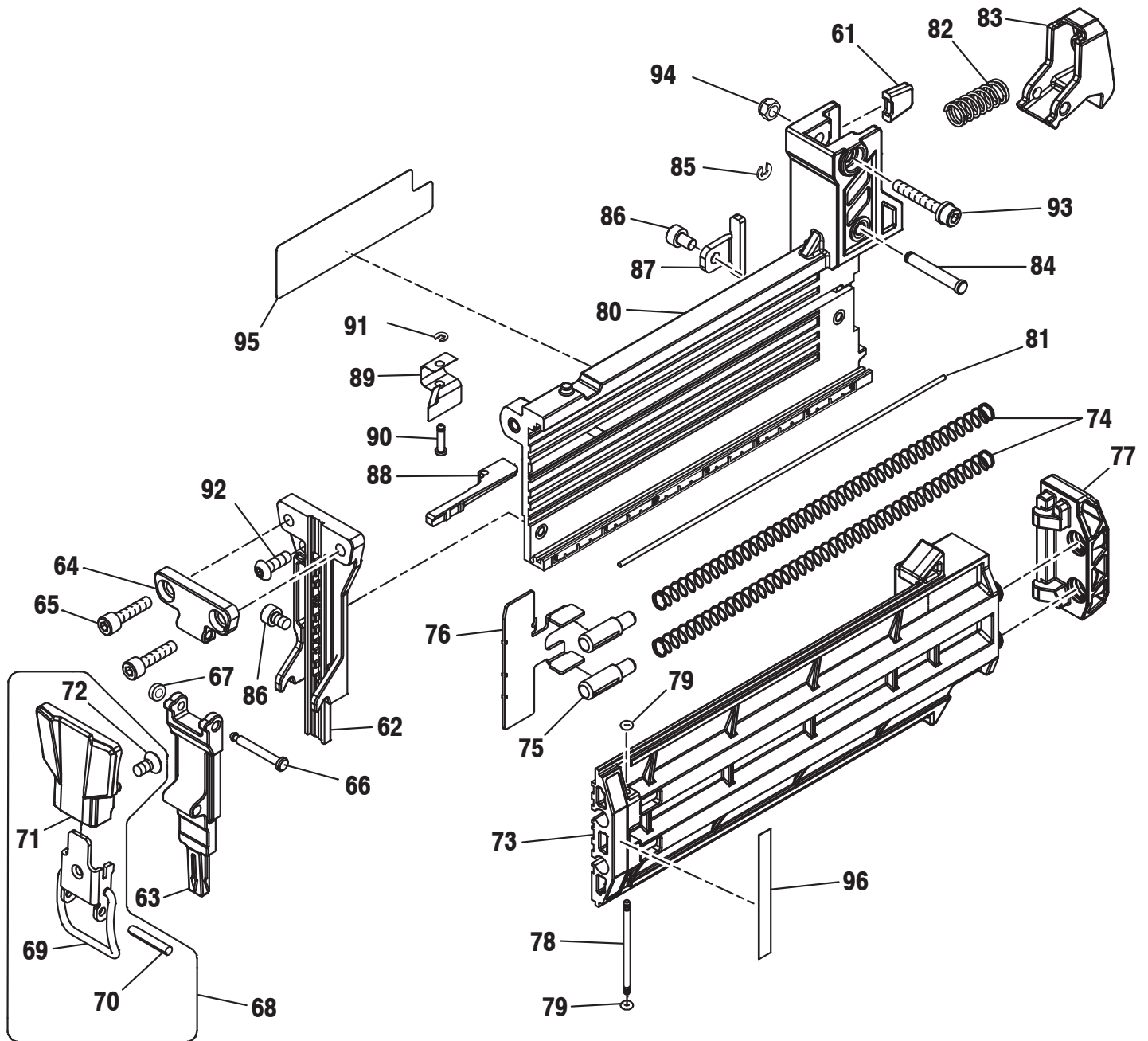

⚠ DANGER: Do not use oxygen, combustible gases, or bottled gases as a power source for this tool. The tool will explode and cause death or serious injury.

⚠ DANGER : Ne pas utiliser de l'oxygène ou des gaz combustibles ou en bouteille pour alimenter l'outil. L'outil exploserait, causant des blessures graves ou mortelles.

⚠ PELIGRO: No utilice oxígeno, gases combustibles ni gases embotellados como fuente de energía para esta herramienta. La herramienta explotará y causará la muerte o lesiones serias.

⚠ WARNING: Disconnect the tool from the air supply before performing maintenance. Failure to do so could result in serious personal injury.

⚠ AVERTISSEMENT : Débrancher l'outil de la source d'air avant tout entretien. Ne pas prendre cette précaution peut entraîner des blessures graves.

⚠ ADVERTENCIA: Desconecte la herramienta del suministro de aire antes de efectuar tareas de mantenimiento. La inobservancia de esta advertencia puede causar lesiones serias.

RIDGID® R213BNE BRAD NAILER

KEY	P/N	DESCRIPTION	QTY	KEY	P/N	DESCRIPTION	QTY
61	079007001093	No Mar Pad.....	1	79	079073001017	O-Ring (2.5 x 1.5).....	2
62	079073001004	Driver Guide	1	80	079073001009	Magazine A (Incl. Key No. 95).....	1
63	079073001022	Driver Guide Cover A	1	81	079007001059	Flat Bar.....	1
64	079073001005	Driver Guide Cover B	1	82	079074001050	Spring.....	1
65	079073001020	Screw (M4 x 18 mm, Soc. Hd.)....	2	83	079074001049	Latch	1
66	079071001053	Pivot Pin.....	1	84	079074001051	Pin (4 x 26.4)	1
67	079071001054	Retainer.....	1	85	079074001052	E-Clip	1
68	079073001705	Jam Release Latch Assembly (Incl. Key Nos. 69-72).....	1	86	079007001058	Screw (M4 x 6 mm, Soc. Hd.).....	2
69	079073001006	Lock Handle Unit	1	87	079073001011	Stop Plate	1
70	079003001064	Roll Pin.....	1	88	079073001010	Dry-Fire Lockout	1
71	079073001008	Jam Release Latch.....	1	89	079007001061	Spring Plate.....	1
72	079073001007	Tapping Screw (M4 x 8 mm)	1	90	079007001060	Fixed Pin	1
73	079073001015	Magazine B	1	91	079007001062	E-Clip (ETW1.5).....	1
74	079073001014	Pusher Spring	2	92	079007001049	Screw (M4 x 12 mm, Soc. Hd.)....	1
75	079073001013	Guide Pin	2	93	079027004038	Screw (M4 x 25 mm, Soc. Hd.)....	1
76	079073001012	Pusher Unit	1	94	079073001021	Nut (M4)	1
77	079073001018	Magazine Bumper.....	1	95	079028006901	Warning and Data Label.....	1
78	079073001016	Pin (2.45 x 40 mm).....	1	96	079028006905	Magazine Label.....	1