

**RIDGID
FINISH STAPLER
MODEL NO. R150FSE
REPAIR SHEET**

**RIDGID
AGRAFEUSE DE FINITION
NO. DE MODÈLE R150FSE
FEUILLE DE RÉPARATION**

**RIDGID
GRAPADORA DE ACABADO
MODELO R150FSE
LISTAS DE PIEZAS DE REPUESTO**

RIDGID

R150FSE

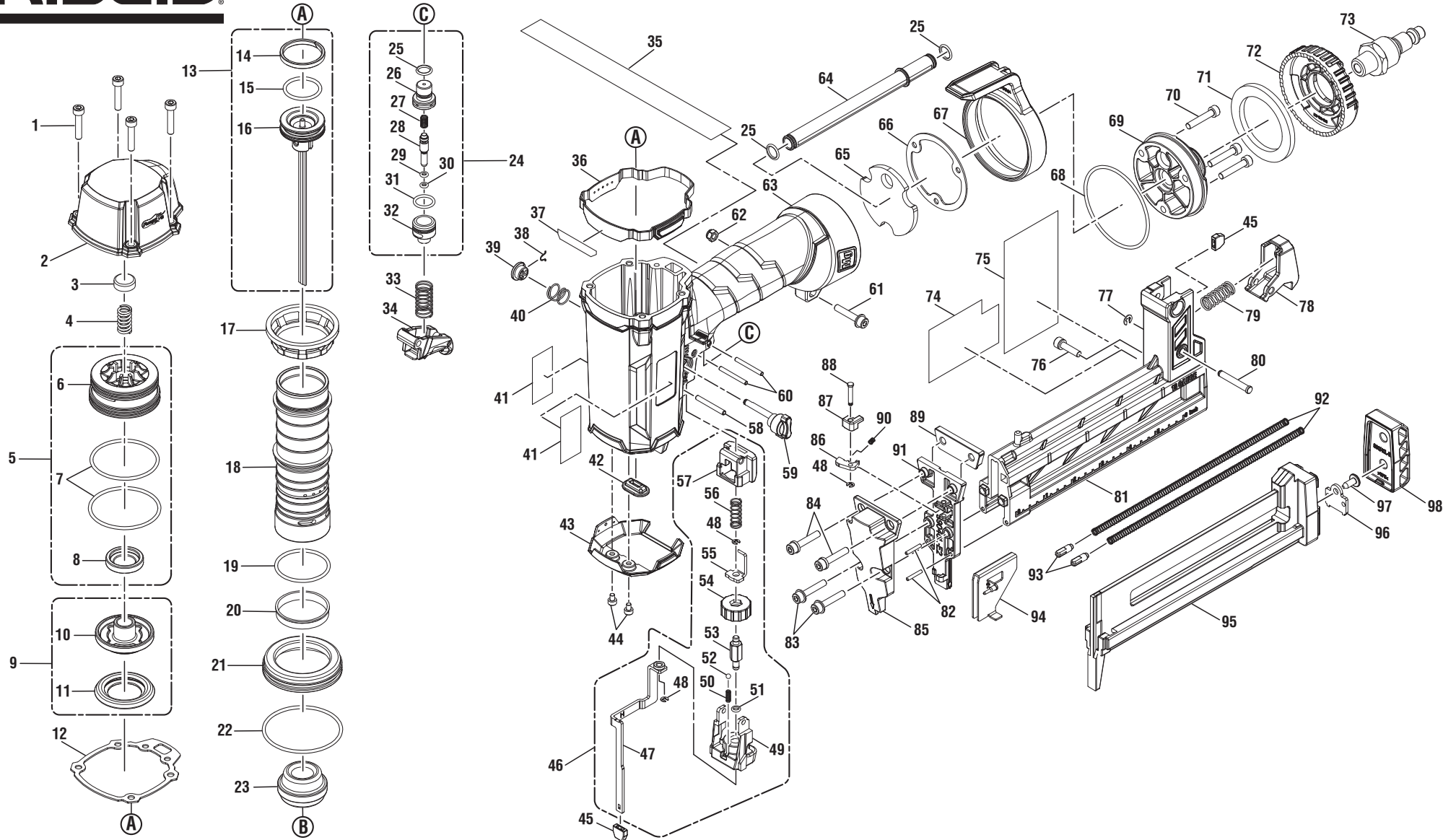

⚠ DANGER: Do not use oxygen, combustible gases, or bottled gases as a power source for this tool. The tool will explode and cause death or serious injury.

⚠ DANGER : Ne pas utiliser de l'oxygène ou des gaz combustibles ou en bouteille pour alimenter l'outil. L'outil exploserait, causant des blessures graves ou mortelles.

⚠ PELIGRO: No utilice oxígeno, gases combustibles ni gases embotellados como fuente de energía para esta herramienta. La herramienta explotará y causará la muerte o lesiones serias.

⚠ WARNING: Disconnect the tool from the air supply before performing maintenance. Failure to do so could result in serious personal injury.

⚠ AVERTISSEMENT : Débrancher l'outil de la source d'air avant tout entretien. Ne pas prendre cette précaution peut entraîner des blessures graves.

⚠ ADVERTENCIA: Desconecte la herramienta del suministro de aire antes de efectuar tareas de mantenimiento. La inobservancia de esta advertencia puede causar lesiones serias.



R150FSE Finish Stapler

KEY	P/N	DESCRIPTION	QTY	KEY	P/N	DESCRIPTION	QTY	KEY	P/N	DESCRIPTION	QTY
1	079071001046	Screw (M4 x 20 mm, Soc Hd.)	4	35	079005004908	Trigger Wrap Label	1	72	079074001015	Exhaust Diverter	1
2	079074001001	Cap	1	36	079074001016	Protection Ring (Upper)	1	73	079001001046	Air Plug (NPT 3/8 in.-18)	1
3	079074001002	Cushion	1	37	079023003905	Fasten Edge Label	1	74	079023003902	Data/Warning Label (English)	1
4	079001001005	Compression Spring	1	38	079071001036	U-Clip	1	75	079023003904	Data/Warning Hangtag (French-Spanish)	1
5	079074001704	Upper Head Valve Assembly (Inc. Key Nos. 6-8)	1	39	079071001035	Mode Selector Button	1	76	079074001053	Screw (M4 x 16 mm, Soc. Hd.)	1
6	079074001003	Head Valve Cylinder	1	40	079071001034	Spring	1	77	079074001052	E-Clip	1
7	079074001004	O-ring (39.5 x 2)	2	41	079023003901	Logo Label	2	78	079074001049	Latch	1
8	079074001005	Oil Seal	1	42	079001001130	Joint Guide	1	79	079074001050	Spring	1
9	079074001705	Lower Head Valve Assembly (Inc. Key Nos. 10-11)	1	43	079074001017	Protection Ring (Lower)	1	80	079074001051	Pin (4 x 26.4)	1
10	079001001006	Head Valve Piston	1	44	079071001049	Screw (M3 x 4 mm, Soc. Hd.)	2	81	079074001041	Magazine Unit (B) (Inc. Key No. 74)	1
11	079001001007	Seal	1	45	079074001040	No Mar Pad	2	82	079074001030	Pin	2
12	079074001006	Gasket	1	46	079074001707	Workpiece Contact Assembly (Inc. Key Nos. 47-58)	1	83	079001001048	Screw (M4 x 22 mm, Soc. Hd.)	2
13	079074001708	Driver Assembly (Inc. Key Nos. 14-16)	1	47	079074001039	Workpiece Contact (B)	1	84	079074001024	Screw (M4 x 22 mm, Soc. Hd.)	2
14	079001001008	Piston Ring	1	48	079001001051	E-Ring	3	85	079074001025	Work Contact Cover	1
15	079001001010	O-ring (23 x 2)	1	49	079074001038	Adjuster Cover (B)	1	86	079074001029	Dry-Fire Lockout	1
16	079074001007	Driver Unit	1	50	079074001037	Spring	1	87	079074001028	Dry-Fire Lockout Bumper	1
17	079001001011	Collar	1	51	079074001036	O-ring (3 x 1.5)	1	88	079074001027	Pivot Pin	1
18	079001001012	Cylinder	1	52	079071001019	Adjustment Ball (3 mm)	1	89	079074001031	Spacer	1
19	079001001013	O-ring (32 x 2)	1	53	079074001035	Adjust Rod Unit	1	90	079001001054	Spring	1
20	079001001014	Cylinder Ring	1	54	079074001034	Adjustment Knob	1	91	079074001026	Driver Guide	1
21	079001001015	Cylinder Spacer	1	55	079074001033	Workpiece Contact (A)	1	92	079074001044	Pusher Spring	2
22	079001001016	O-ring (47.5 x 2)	1	56	079001001077	Spring	1	93	079074001043	Shaft	2
23	079001001017	Bumper	1	57	079074001032	Adjuster Cover (A)	1	94	079074001042	Pusher Unit	1
24	079074001706	Trigger Valve Assembly (Inc. Key Nos. 25-32, 38 and 60)	1	58	079074001022	Spring Pin (D3 x 25)	1	95	079074001045	Magazine Unit (A)	1
25	079001001033	O-ring (7.5 x 1.5)	3	59	079071001033	Mode Selector Switch	1	96	079074001046	Retaining Plate	1
26	079074001018	Trigger Valve Head	1	60	079074001021	Spring Pin (D2.5 x 24)	2	97	079074001047	Tap Screw	1
27	079001001022	Spring	1	61	079074001054	Screw (M4 x 22 mm, Soc. Hd.)	1	98	079074001048	Magazine Bumper	1
28	079001001023	Plunger	1	62	079071001062	Nut (M4)	1	Not Shown:			
29	079071001029	O-ring (2.5 x 1.5)	1	63	079074001008	Tool Body Unit	1	079074001701	Overhaul Maintenance Kit (Inc. Key Nos. 6-8, 10-12, 19-20, 22-23, 25-32 and 38)		1
30	079001001025	O-ring (2.5 x 1.5)	1	64	079001001034	Exhaust Tube	1	079074001702	Driver Maintenance Kit (Inc. Key Nos. 12, 14-16 and 23)		1
31	079074001019	O-ring (11 x 1.6)	1	65	079074001009	Filter	1	988000668	Operator's Manual		1
32	079074001020	Plunger Cap	1	66	079074001010	Gasket	1	3-12-14			
33	079001001030	Spring	1	67	079074001011	Belt Hook	1	(Rev:01)			
34	079074001023	Trigger Assembly (Inc. Key No. 33)	1	68	079074001012	O-ring (52.5 x 2)	1				
				69	079074001013	End Cap (NPT 1/4 in.-18)	1				
				70	079001001074	Screw (M4 x 22 mm, Soc. Hd.)	3				
				71	079074001014	Muffler	1				