

## PG530

Reservdelar

Spare parts

Ersatzteile

Pieces de rechange

Piezas de repuesto

Ricambi

Peças sobresselente

# A1

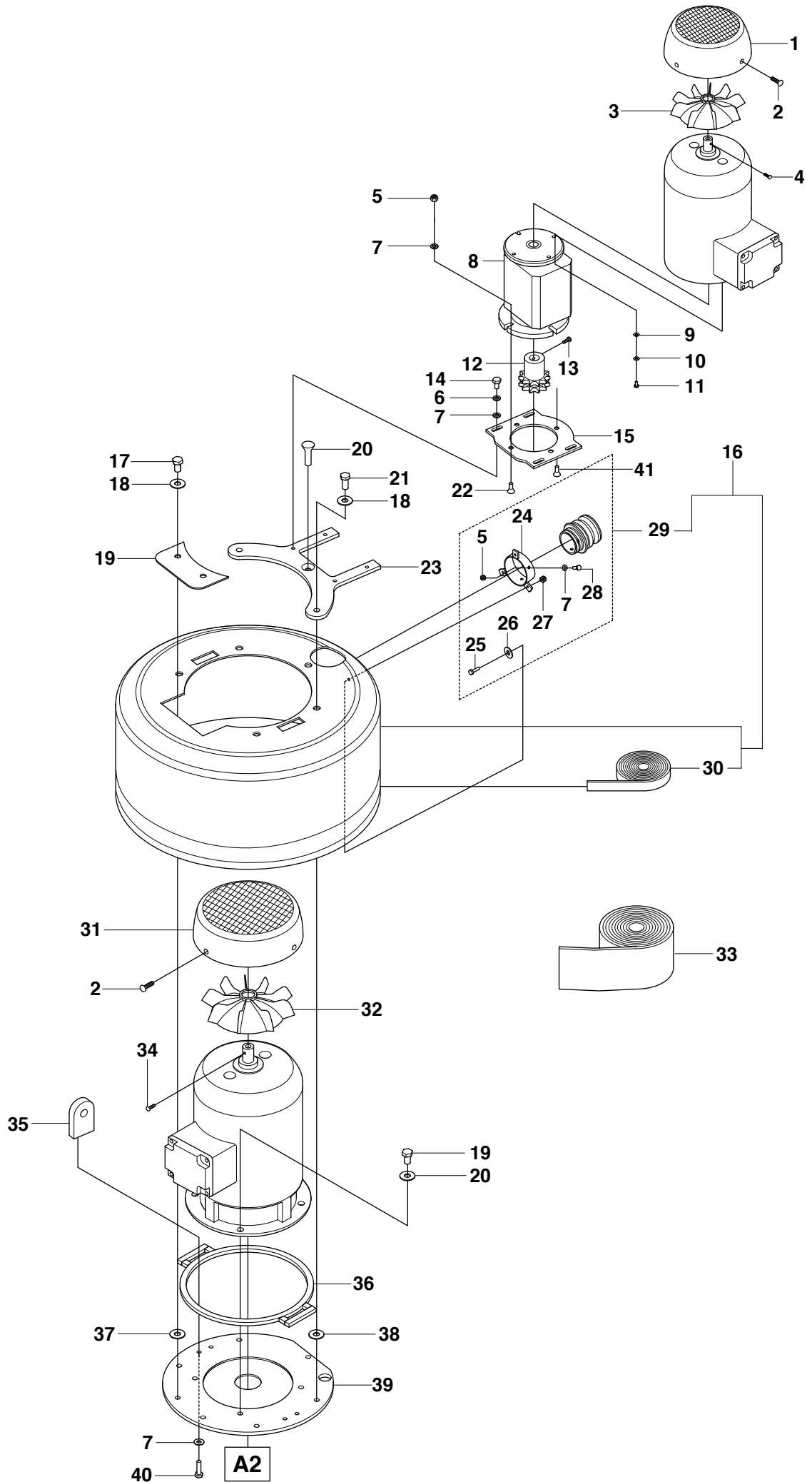

Position	Article	Description	Quantity	Notes	Kit
1	522 65 84-01	FAN COVER	1		
2	723 13 20-51	SCREW	7		
3	522 65 86-01	FAN	1		
4	522 65 85-01	PIN	1		
5	732 25 18-01	NUT	6		16,29
6	735 11 64-01	WASHER	4		
7	734 11 63-01	WASHER	13		16,29
8	580 99 98-01	GEAR BOX	1		
9	734 11 52-01	WASHER	4		
10	735 11 53-01	WASHER	4		
11	725 23 72-71	SCREW	4		
12	502 56 40-01	SPROCKET	1		
13	541 40 51-78	SCREW	2		
14	725 24 49-76	SCREW	4		
15	502 56 16-01	PLATE	1		
16	522 65 89-01	COVER ASSY	1		
17	725 25 34-71	SCREW	8		
18	734 11 78-01	WASHER	10		
19	504 72 51-01	COVER PLATE	1		
20	522 65 81-01	SCREW	1		
21	725 25 36-71	SCREW	2		
22	725 64 53-51	SCREW	3		
23	502 56 15-01	BRACKET	1		
24	522 65 87-01	BRACKET	1		16,29
25	724 33 70-51	SCREW	3		16,29
26	504 74 73-01	WASHER	2		
27	732 25 16-01	NUT	3		16,29
28	725 24 53-76	SCREW	2		16,29
29	522 65 88-01	EXTRACTION PORT ASSY	1		16,29
30	502 53 85-01	VELCRO	1		16
31a	505 55 66-01	MAIN MOTOR FAN COVER KW	1		
31b	522 65 90-01	MAIN MOTOR FAN COVER KW	1		
32a	505 55 65-01	MAIN MOTOR FAN KW	1		
32b	522 65 92-01	MAIN MOTOR FAN KW	1		
33	502 55 89-01	SKIRT	1		
34	522 65 93-01	PIN	1		
35	504 72 56-01	LIFTING LUG	2		
36	502 56 87-01	SEAL	1		
37	504 72 63-04	WASHER	2		
38	504 72 95-01	WASHER	5		
39	502 56 13-01	PLATE	1		
40	725 24 55-76	SCREW	4		
41	725 64 51-55	SCREW	1		

# A2

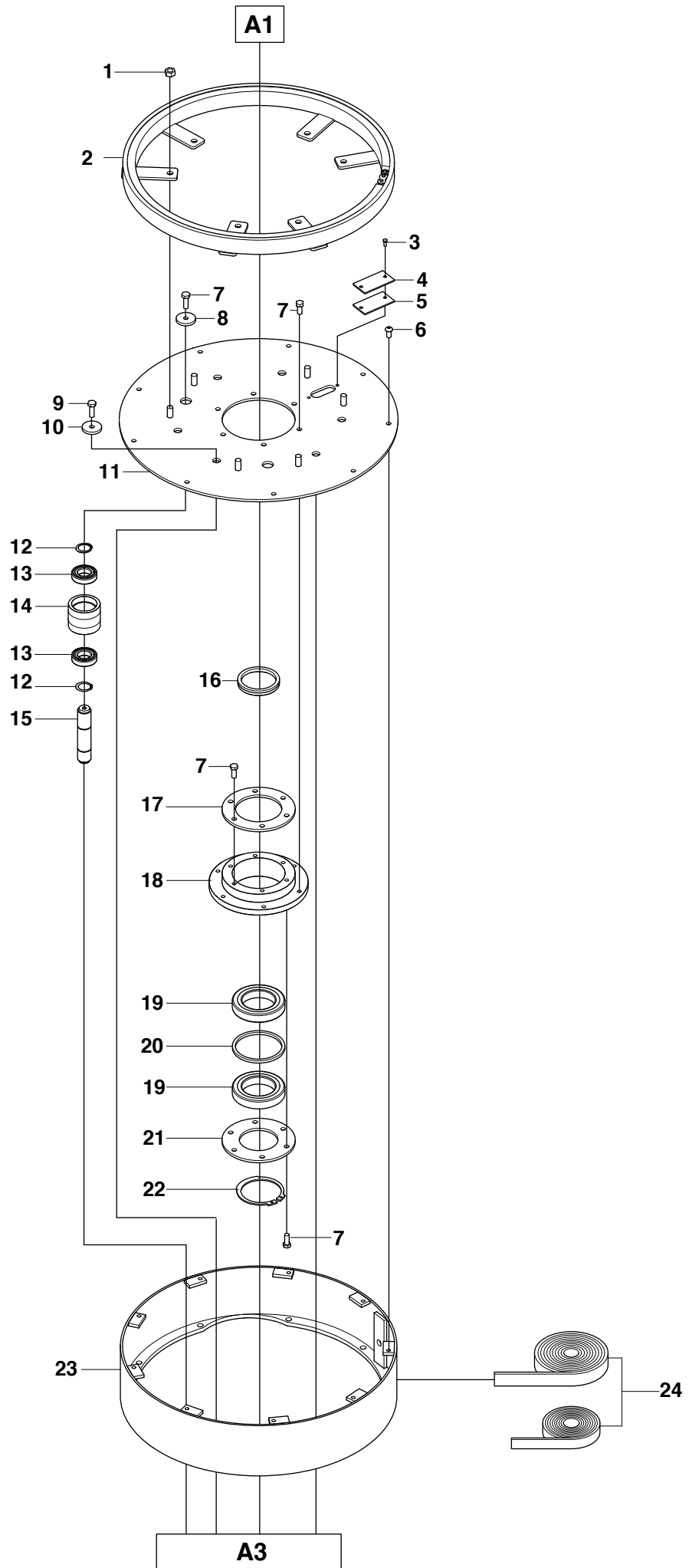

Position	Article	Description	Quantity	Notes	Kit
1	732 25 20-01	NUT	6		
2	502 56 23-01	CHAIN RING	1		
3	724 13 64-51	SCREW	2		
4	504 72 79-01	COVER PLATE	1		
5	516 05 85-01	SEAL	1		
6	522 61 99-01	SCREW	9		
7	725 24 51-76	SCREW	20		
8	543 04 66-47	WASHER	2		
9	522 62 01-01	SCREW	6		
10	734 11 82-01	WASHER	6		
11	502 56 11-01	TOP PLATE	1		
12	735 31 26-00	CIRCLIP	2		
13	502 56 28-01	BALL BEARING	2		
14	502 56 04-01	PULLEY	1		
15	502 56 03-01	SHAFT	2		
16	502 53 98-01	SEAL	1		
17	504 72 50-01	PLATE	1		
18	502 56 08-01	BEARING HOUSING	1		
19	502 56 26-01	BALL BEARING	2		
20	504 72 48-01	SPACER	1		
21	504 72 49-01	PLATE	1		
22	502 53 96-01	CIRCLIP	1		
23	502 56 20-01	RIM	1		
24	502 53 48-01	SEAL RUBBER	1		

**A3**

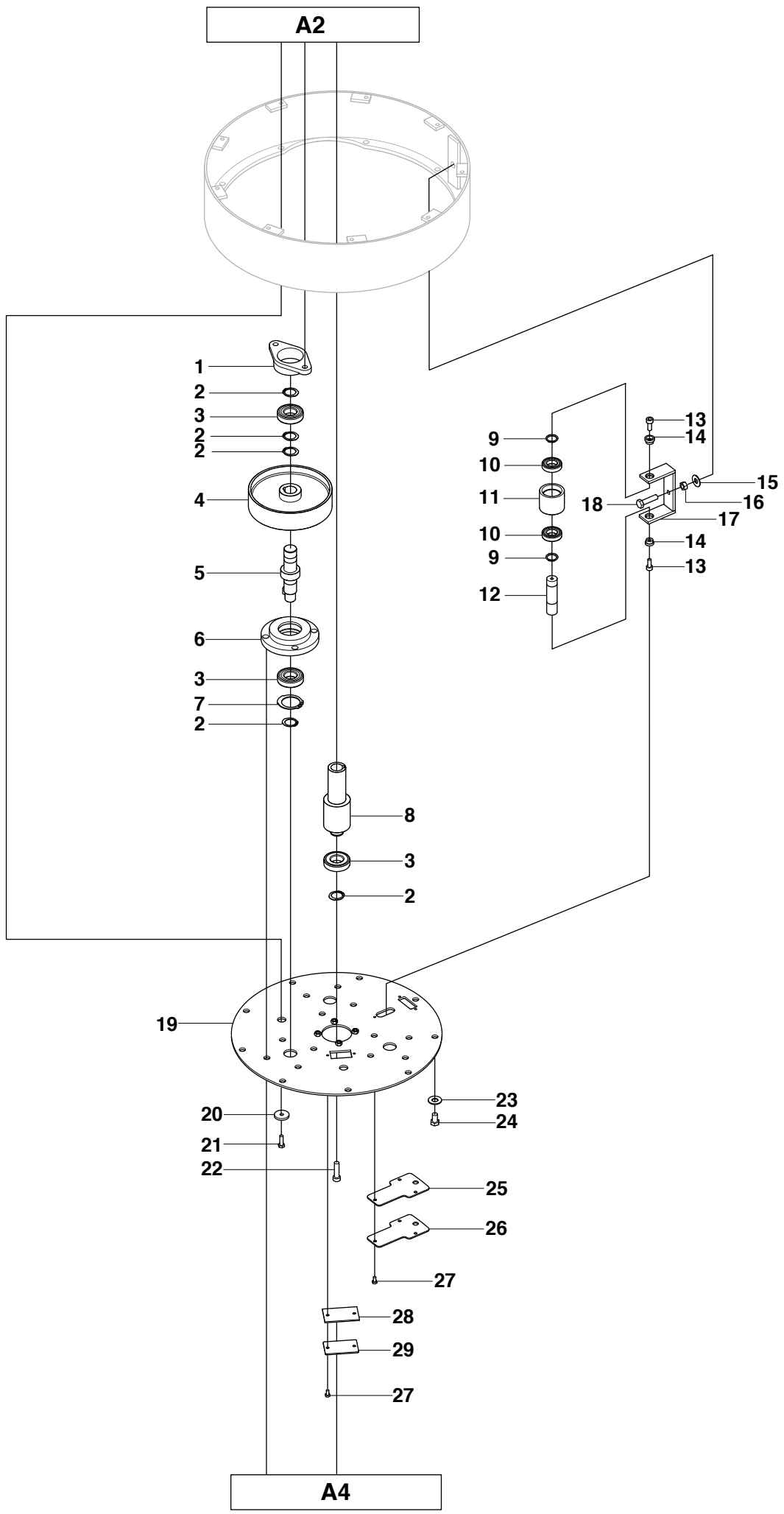

Position	Article	Description	Quantity	Notes	Kit
1	502 56 07-01	BEARING HOUSING	3		
2	735 31 30-00	CIRCLIP	13		
3	502 56 24-01	BALL BEARING	7		
4	502 56 00-01	PULLEY	3		
5	502 56 02-01	SHAFT	3		
6	502 56 06-01	BEARING HOUSING	3		
7	502 56 33-01	CIRCLIP	3		
8	502 56 01-01	PULLEY	1		
9	735 31 26-00	CIRCLIP	2		
10	502 56 28-01	BALL BEARING	2		
11	502 56 04-01	BEARING HOUSING	1		
12	502 56 05-01	SHAFT	1		
13	725 54 51-01	SCREW	2		
14	504 72 42-01	NUT	2		
15	734 11 72-01	WASHER	1		
16	731 23 20-01	NUT	1		
17	502 56 19-01	FRAME	1		
18	725 24 99-71	SCREW	1		
19	502 56 12-01	PLATE	1		
20	543 04 66-47	WASHER	2		
21	725 24 51-76	SCREW	2		
22	522 62 02-01	SCREW	1		
23	734 11 78-01	WASHER	9		
24	725 25 34-71	SCREW	9		
25	522 65 95-01	SEAL	1		
26	504 72 55-01	COVER PLATE	1		
27	725 23 66-71	SCREW	5		
28	516 05 85-01	SEAL	1		
29	504 72 79-01	COVER PLATE	1		

# A4

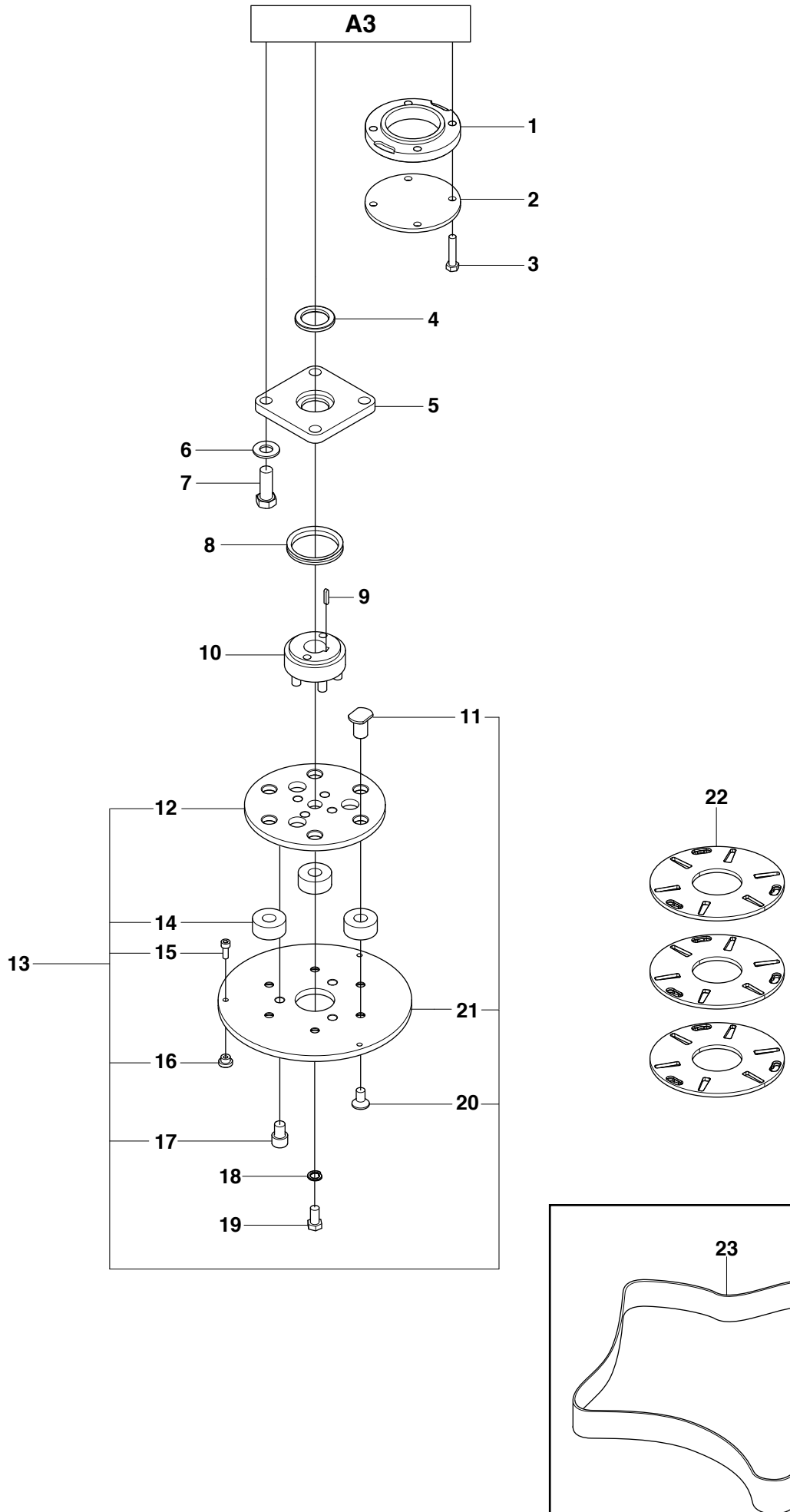



Position	Article	Description	Quantity	Notes	Kit
1	502 56 09-01	BEARING HOUSING	1		
2	502 56 14-01	COVER PLATE	1		
3	725 24 55-76	SCREW	4		
4	502 56 34-01	RADIAL SEAL	3		
5	504 75 98-01	HOUSING	3		
6	734 11 82-01	WASHER	12		
7	522 62 03-01	SCREW	12		
8	502 56 36-01	SEAL	3		
9	522 65 96-01	PARALLEL KEY	3		
10	502 56 10-01	HEAD BOSS	3		
11	522 65 98-03	PIN	18		13
12	522 65 97-01	PLATE	3		13
13	502 55 82-01	GRINDING HEAD	3		
14	502 53 39-01	SILICONE WASHER	9		13
15	725 53 68-51	SCREW	9		13
16	502 53 44-01	LOCK	9		13
17	504 74 84-01	SCREW	9		13
18	504 74 96-02	SPRING WASHER	3		
19	522 66 18-01	SCREW	3		
20	725 64 91-51	SCREW	18		13
21	522 65 98-02	PLATE	3		13
22	502 54 58-01	PLATES	3		
23	502 56 39-01	DRIVE BELT	1		

# B1

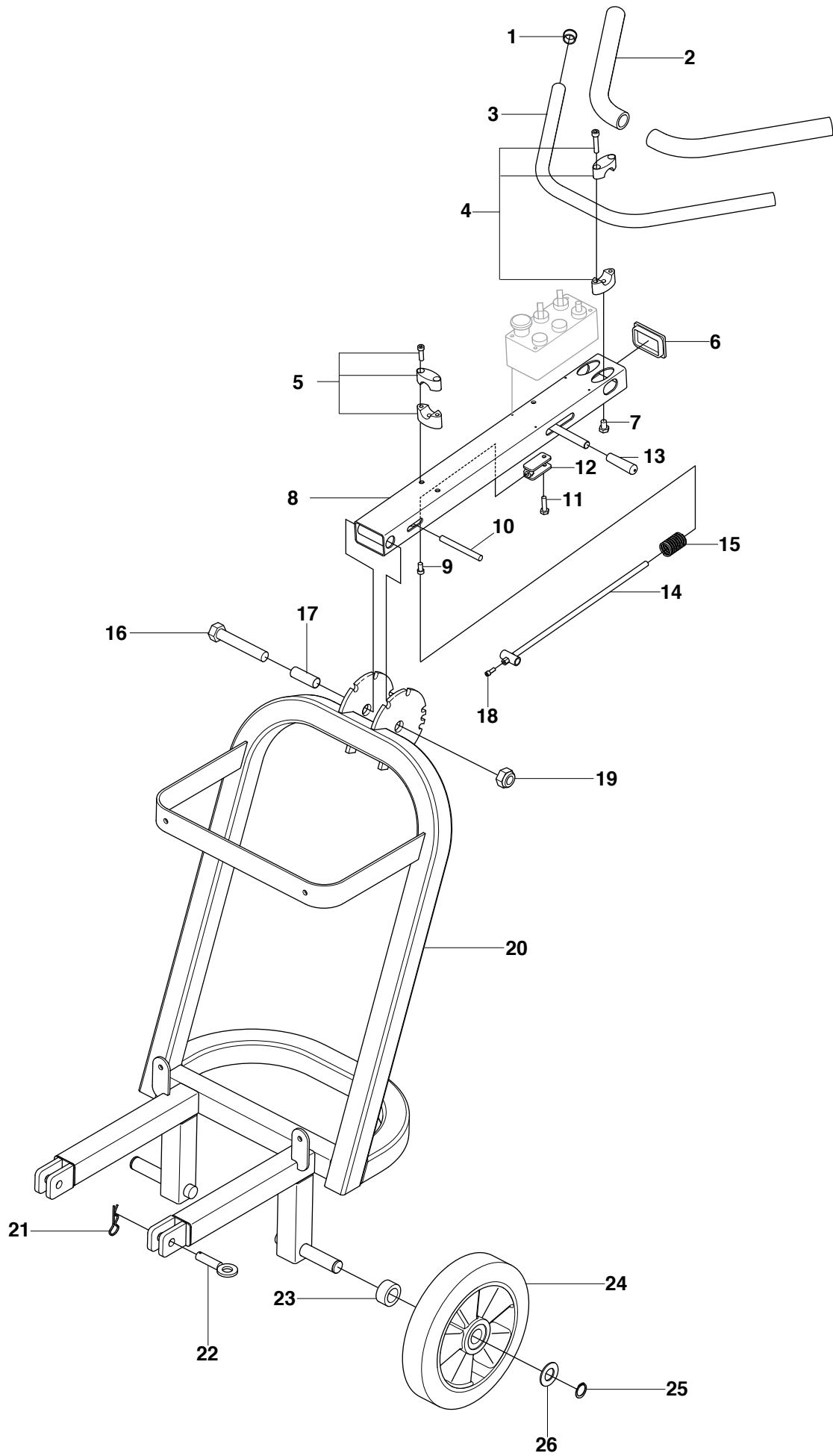

Position	Article	Description	Quantity	Notes	Kit
1	543 04 60-41	END STOP	2		
2	502 54 49-22	RUBBER COVER	2		
3	502 56 65-13	HANDLE TUBE	1		
4	502 54 49-25	HANDLE BAR	2		
5	502 54 49-26	HANDLE BAR	1		
6	516 05 90-01	END STOP	1		
7	725 24 89-76	SCREW	2		
8	502 56 65-02	HANDLE BAR	1		
9	725 54 45-01	SCREW	2		
10	516 05 93-01	PIN	1		
11	725 24 55-76	SCREW	1		
12	502 54 49-05	BRACKET	1		
13	502 54 49-23	RUBBER	1		
14	522 65 99-01	ROD	1		
15	502 54 49-27	COMPRESSION SPRING	1		
16	504 75 07-01	SCREW	1		
17	516 05 97-01	SLEEVE	1		
18	724 13 64-51	SCREW	1		
19	504 75 06-01	NUT	1		
20	502 56 64-01	FRAME	1		
21	721 68 02-51	HAIR PIN COTTER	2		
22	504 72 97-01	PIN	2		
23	504 72 77-07	SPACER TUBE	2		
24	502 54 50-01	WHEEL	2		
25	735 31 26-00	CIRCLIP	2		
26	504 75 14-01	WASHER	2		

# B2

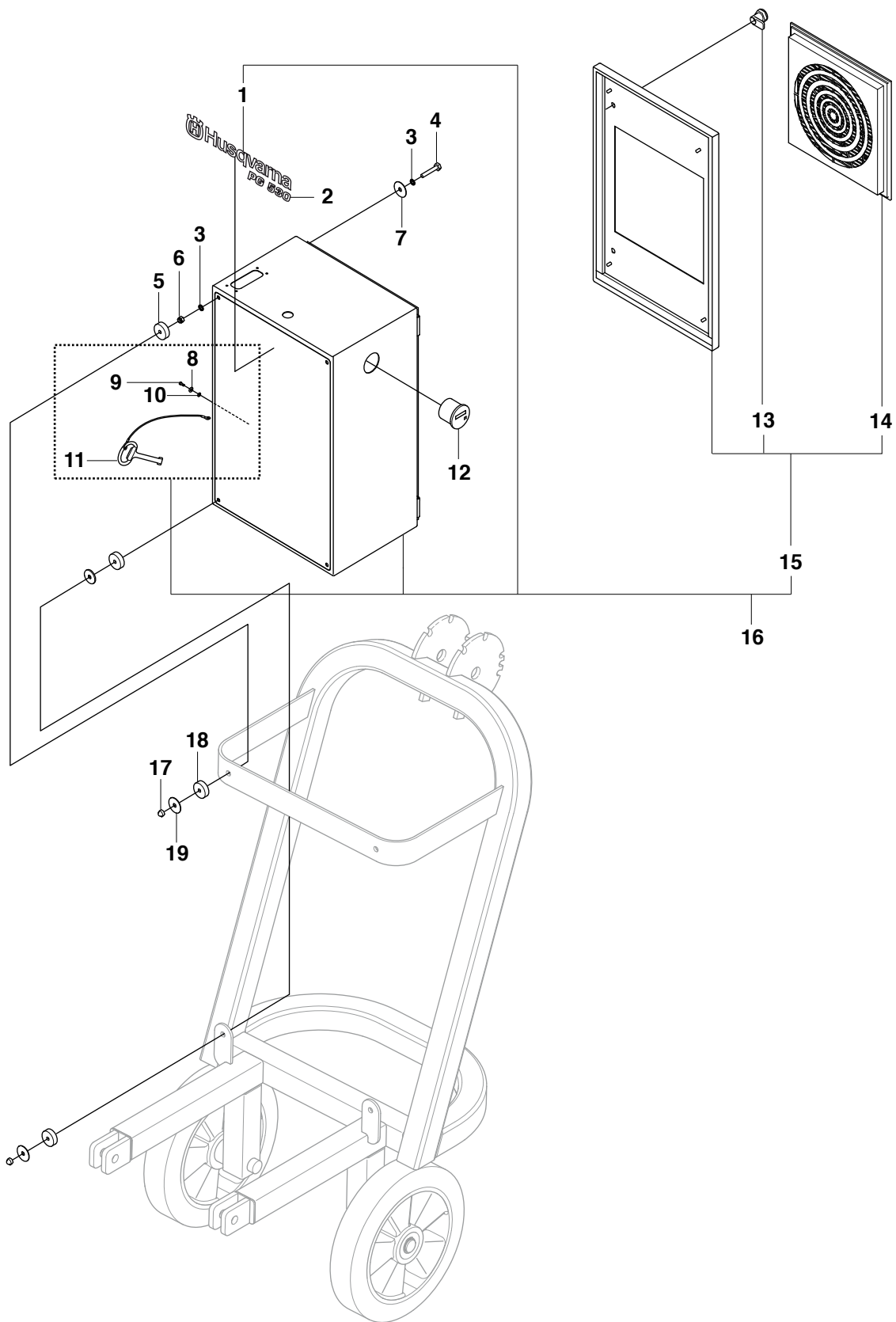

Position	Article	Description	Quantity	Notes	Kit
1	525 48 88-01	DECAL / HUSQVARNA	1		16
2	525 48 85-01	DECAL / MODEL	1		
3	735 21 64-01	TOOTH WASHER	8		
4	725 24 61-71	SCREW	4		
5	502 53 39-01	SILICON SPRING	4		
6	732 25 18-01	LOCK NUT	4		
7	504 74 73-01	WASHER	4		
8	735 11 53-01	LOCK WASHER	1		
9	541 40 51-78	SCREW	1		
10	734 11 52-01	WASHER	1		
11	574 44 11-01	KEY	1		
12a	504 74 13-01	HOUR METER	1		
12b	580 88 17-01	HOUR METER	1		
13	516 05 98-01	LOCK	2		16,15
14	502 54 41-01	VENT KIT	1		16,15
15	574 44 10-01	E-BOX DOOR KIT	1		16
16a	574 44 08-01	E-BOX KIT	1		
16b	574 44 08-02	E-BOX KIT	1	UL	
17	543 04 47-66	NUT	4		
18	515 98 41-01	SILICONE WASHER	4		
19	521 88 67-01	WASHER	4		

# C1

Single phase	C2
3 phase	C3
Single phase	C4
3 phase	C5

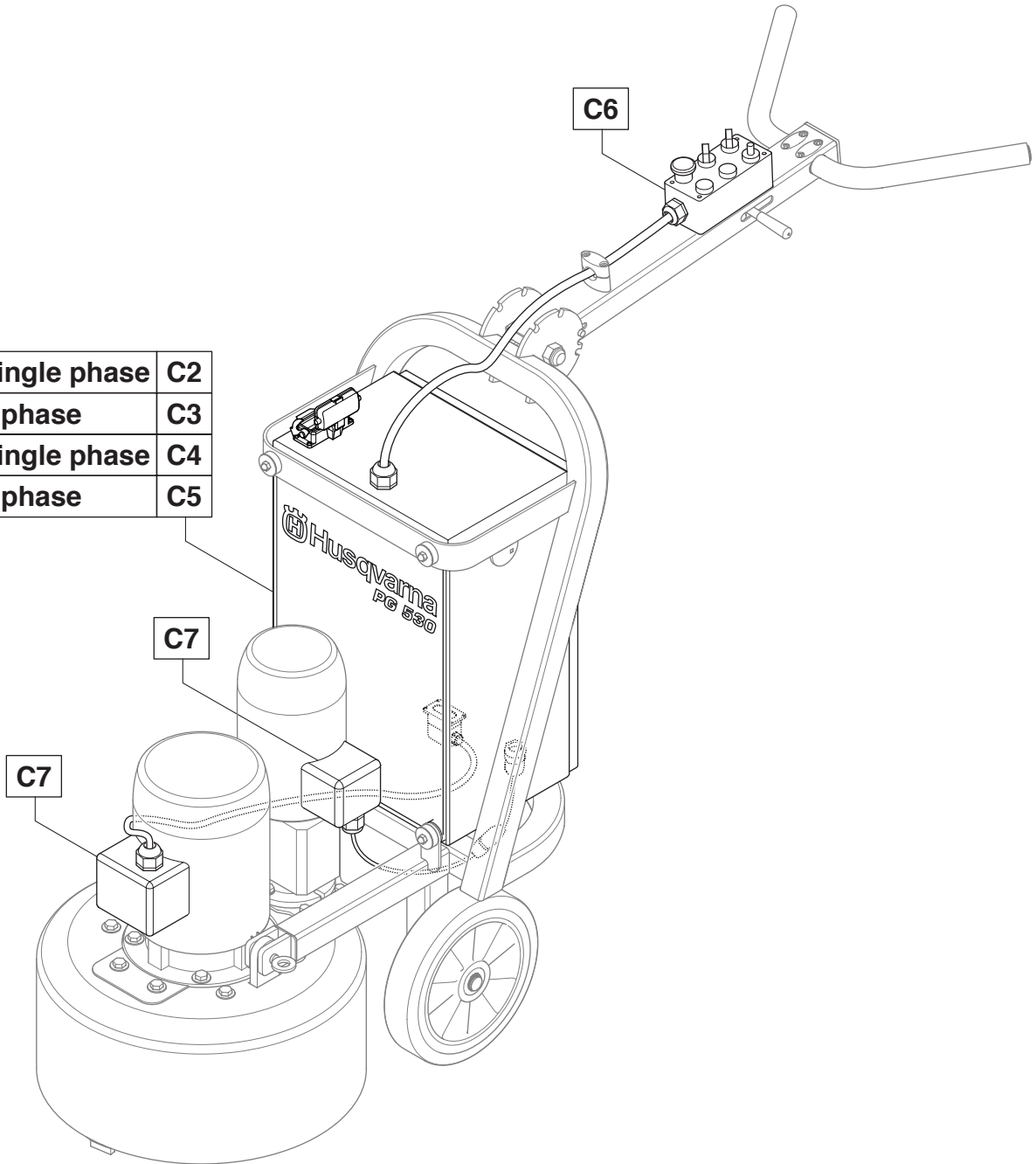



# C2

## Single Phase

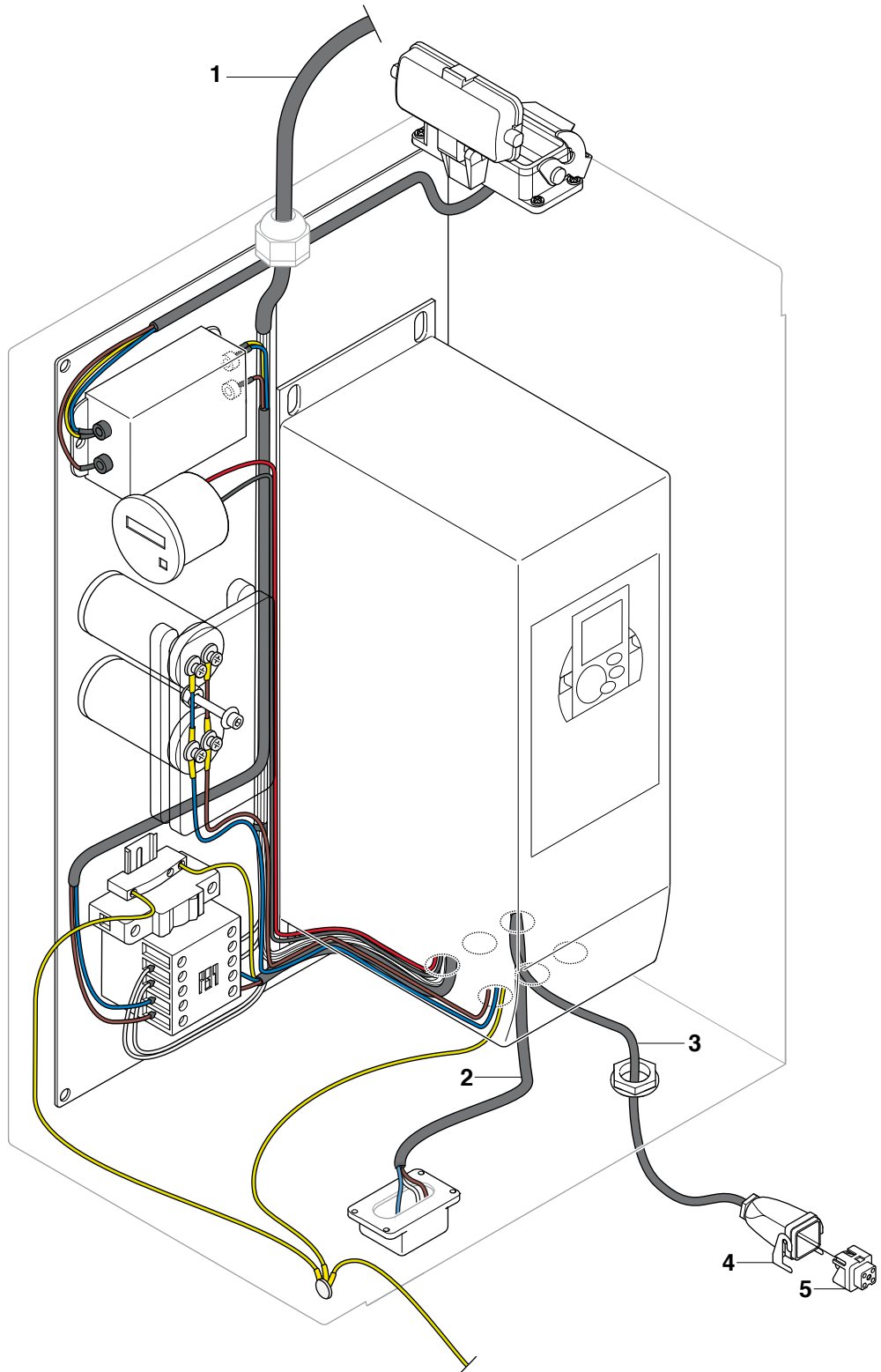



Position	Article	Description	Quantity	Notes	Kit
1a	504 75 39-01	CONTROL PANEL LOOM	1		
1b	581 11 08-01	CONTROL PANEL LOOM	1	UL	
2a	522 66 00-01	CABLE	1	CE	
2b	522 66 00-02	CABLE	1	UL	
3a	522 66 01-01	CABLE	1		
3b	522 66 01-02	CABLE	1	UL	
4	522 66 14-01	PLUG	1		
5	522 66 16-01	CONNECTOR	1		

# C3

3 phase

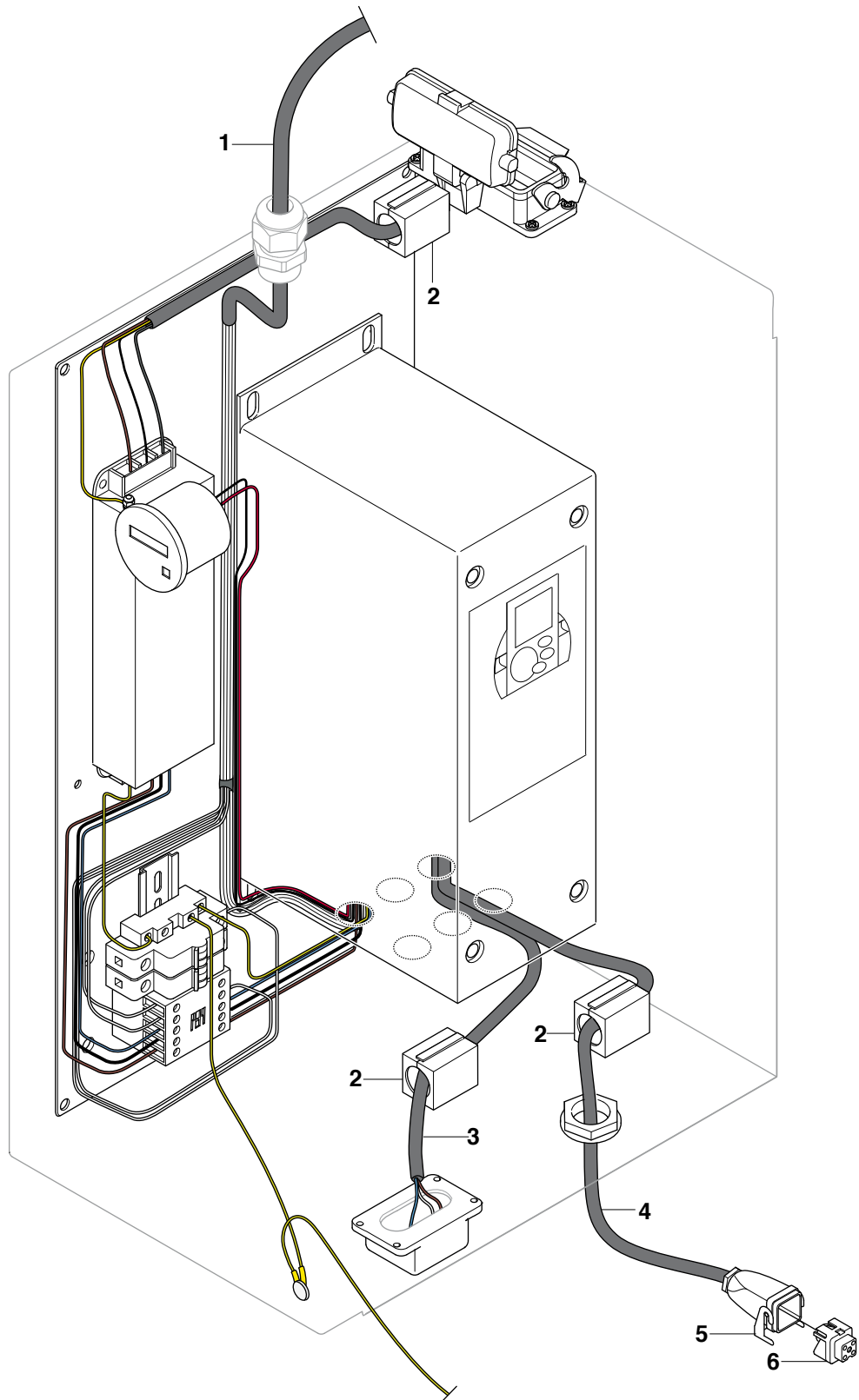

Position	Article	Description	Quantity	Notes	Kit
1a	504 75 39-01	CONTROL PANEL LOOM	1		
1b	581 11 08-01	CONTROL PANEL LOOM	1	UL	
2	504 71 72-01	FERRITE	3		
3a	522 66 02-01	CABLE	1		
3b	522 66 02-02	CABLE	1	UL	
4a	522 66 01-01	CABLE	1		
4b	522 66 01-02	CABLE	1	UL	
5	522 66 14-01	PLUG	1		
6	522 66 16-01	CONNECTOR	1		

# C4

## Single Phase

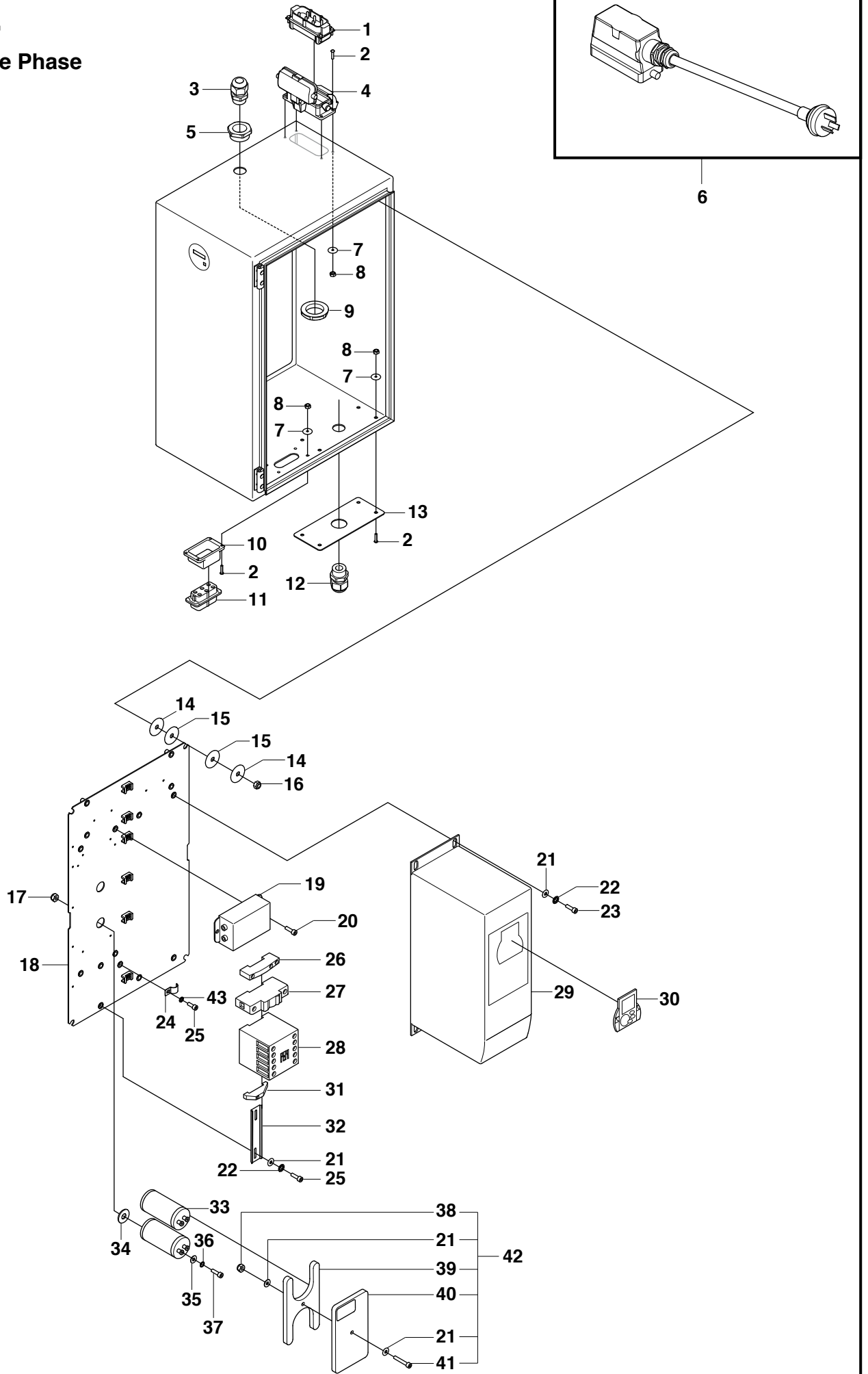

Position	Article	Description	Quantity	Notes	Kit
1	516 06 15-01	CONNECTOR	1		
2	724 12 93-51	SCREW	12		
3	516 06 18-01	CABLE GLAND	1		
4	516 06 06-02	HOUSING	1		
5	504 76 24-01	ADAPTER	1		
6a	525 58 45-01	CABLE KIT	1	AU	
6b	525 58 45-02	CABLE KIT	1	EU	
6c	525 58 45-03	CABLE KIT	1	CH	
6d	525 58 45-04	CABLE KIT	1	US	
7	734 11 36-01	WASHER	12		
8	732 25 12-01	NUT	12		
9	575 51 01-01	NUT	1		
10	516 06 04-01	HOUSING	1		
11	516 06 05-01	CONNECTOR	1		
12	516 06 12-01	CABLE GLAND	1		
13	525 31 14-01	COVER PLATE	1		
14	521 88 67-01	WASHER	8		
15	516 06 01-01	WASHER	8		
16	732 25 18-01	NUT	4		
17	504 75 35-01	NUT	2		
18	574 44 12-01	BACKING BOARD	1		
19	504 71 70-01	EMI FILTER	1		
20	521 88 64-02	SCREW	2		
21	734 11 54-41	WASHER	8		42
22	735 11 53-01	WASHER	6		
23	725 53 70-51	SCREW	4		
24	504 75 84-01	CLAMP	1		
25	725 53 68-01	SCREW	3		
26	502 54 38-01	TERMINAL BLOCK	1		
27a	504 75 37-01	CIRCUIT BREAKER	1		
27b	578 35 06-01	CIRCUIT BREAKER	1	UL	
28	504 75 36-01	CONTACTOR	1		
29	502 56 43-01	FREQUENCY INVERTER	1		
30 a	516 06 10-01	NXL PANEL	1		
30 b	505 46 40-01	NXS KEYPAD	1		
31	504 73 99-01	CLAMP	1		
32	516 06 11-01	RAIL	1		
33	504 75 33-01	CAPACITOR	2		
34	504 75 34-01	WASHER	2		
35	734 11 46-01	WASHER	4		
36	735 11 46-01	WASHER	4		
37	725 23 27-71	SCREW	4		
38	732 25 16-01	NUT	1		42
39	522 66 06-01	COVER BACK	1		42
40	522 66 07-01	COVER FRONT	1		42
41	725 53 74-01	SCREW	1		42
42	522 66 08-01	COVER ASSY	1		
43	735 21 53-01	WASHER	1		

# C5

3 Phase

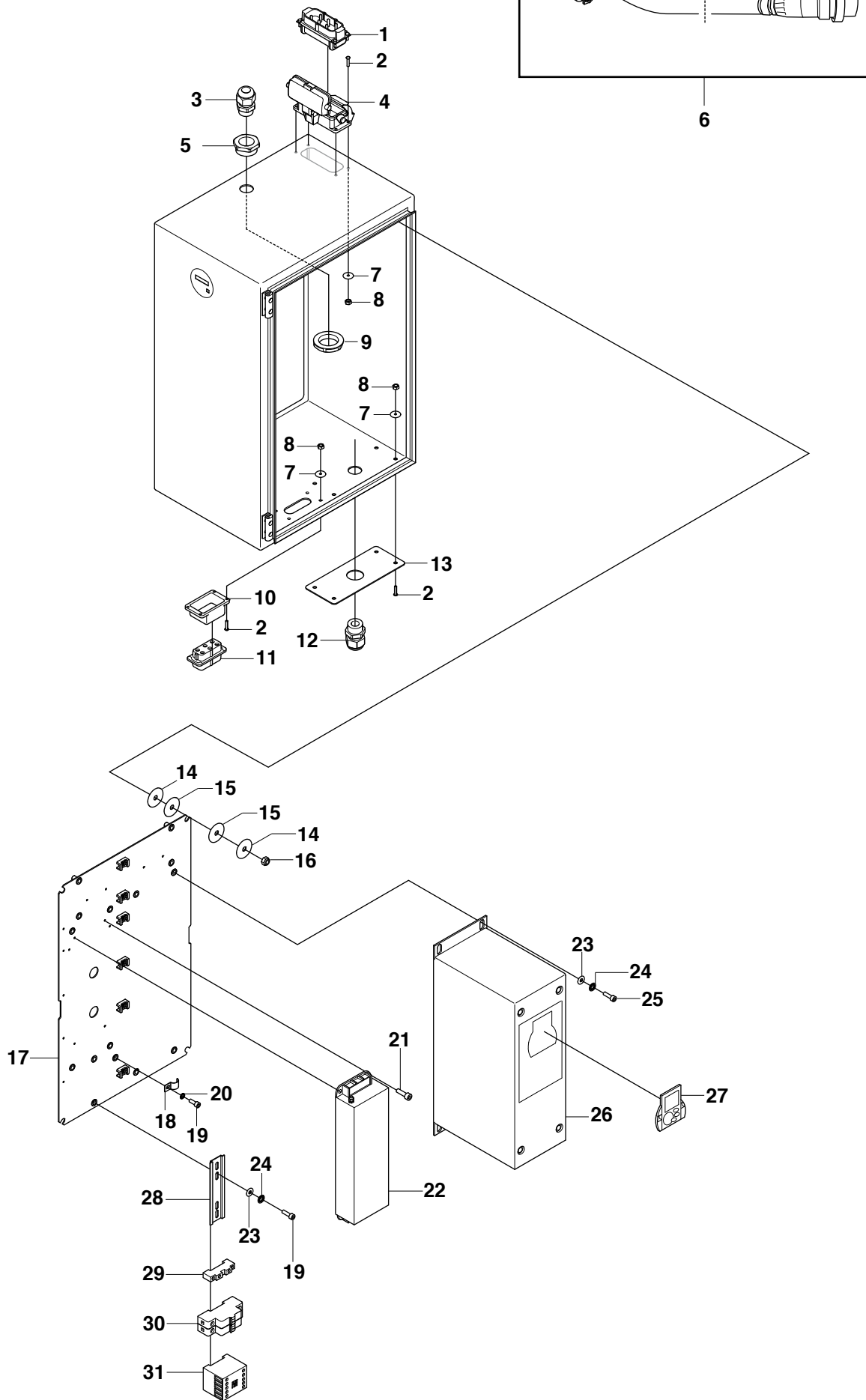

Position	Article	Description	Quantity	Notes	Kit
1	504 76 25-01	CONNECTOR	1		
2	724 12 93-51	SCREW	12		
3	516 06 18-01	GLAND	1		
4	516 06 06-02	HOUSING	1		
5	504 76 24-01	REDUCER	1		
6a	574 44 13-02	PLUG	1	AU	
6b	531 11 71-36	PLUG	1	EU	
6c	580 95 23-01	PLUG	1	UL	
7	734 11 36-01	WASHER	12		
8	732 25 12-01	NUT	12		
9	575 51 01-01	NUT	1		
10	516 06 04-01	HOUSING	1		
11	516 06 05-01	CONNECTOR	1		
12	516 06 12-01	GLAND	1		
13	525 31 14-01	COVER PLATE	1		
14	521 88 67-01	WASHER	8		
15	516 06 01-01	WASHER	8		
16	732 25 18-01	NUT	4		
17	574 44 12-01	BACKING PLATE	1		
18	504 75 84-01	CLAMP	1		
19	725 53 68-01	SCREW	3		
20	735 21 53-01	WASHER	1		
21	521 88 64-02	SCREW	4		
22	522 66 10-01	EMI FILTER	1		
23	734 11 54-41	WASHER	6		
24	735 11 53-01	WASHER	6		
25	725 53 70-51	SCREW	4		
26	502 56 41-01	FREQUENCY INVERTER	1		
27a	516 06 10-01	NXL PANEL	1		
27b	505 46 40-01	NXS KEYPAD	1		
28	516 06 11-01	DIN RAIL	1		
29	502 54 38-01	TERMINAL BLOCK	1		
30a	502 54 37-01	CIRCUIT BREAKER	1		
30b	578 35 05-01	CIRCUIT BREAKER	1	UL	
31	502 56 53-01	CONTACTOR	1		

# C6

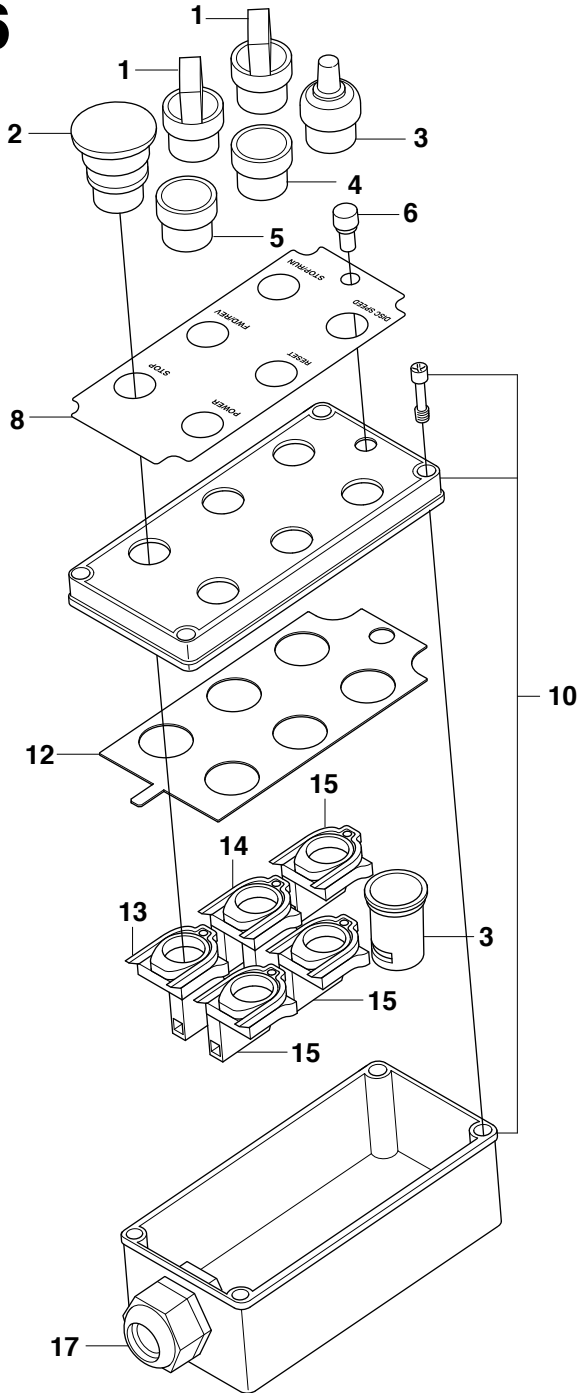

**3 Phase**

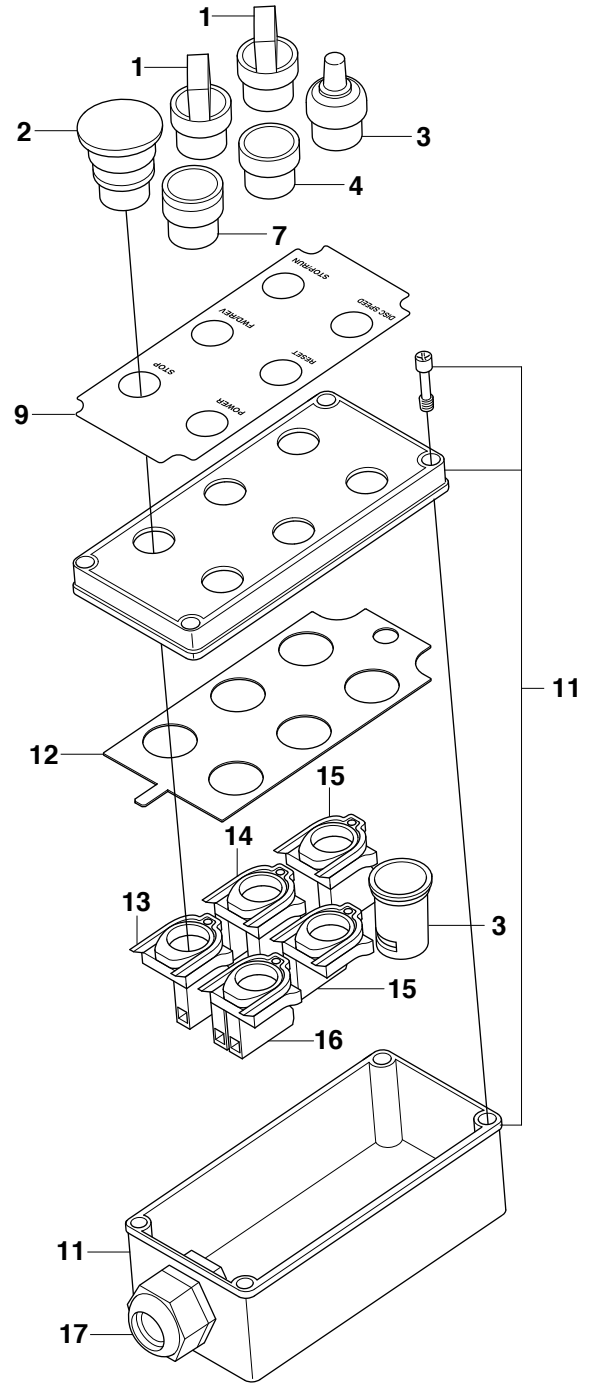
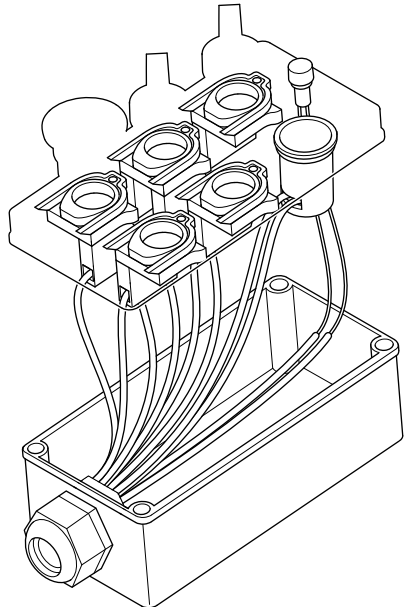

**Single Phase**

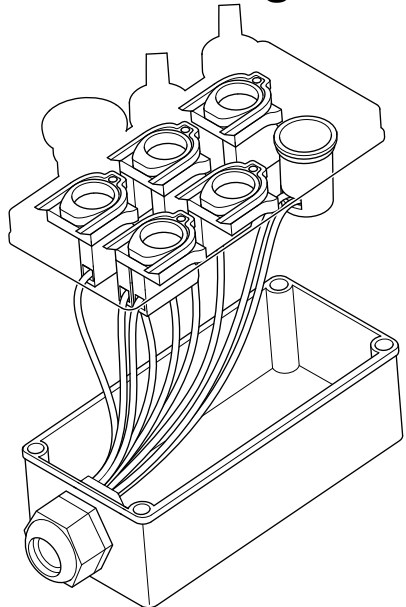



Position	Article	Description	Quantity	Notes	Kit
1	504 73 86-01	SWICH	2		
2	504 73 94-01	BUTTON	1		
3	502 54 29-01	POTENTIOMETER	1		
4	504 73 88-01	PUSH BUTTON	1		
5	504 73 90-01	PUSH BUTTON	1		
6a	504 73 96-01	LAMP	1		
6b	580 88 16-01	LAMP	1	UL	
7	504 75 50-01	PUSH BUTTON	1		
8	522 67 69-01	DECAL	1		
9	504 75 56-01	DECAL	1		
10	522 66 11-01	CONTROL PANEL	1		
11	504 75 43-01	CONTROL PANEL	1		
12	525 73 65-01	EARTHING PLATE	1		
13	504 73 95-01	BUTTON BODY	1		
14	504 73 87-01	BUTTON BODY	1		
15	504 73 89-01	BUTTON BODY	2-3		
16	504 75 51-01	BUTTON BODY	1		
17	516 06 18-01	GLAND	1		

# C7

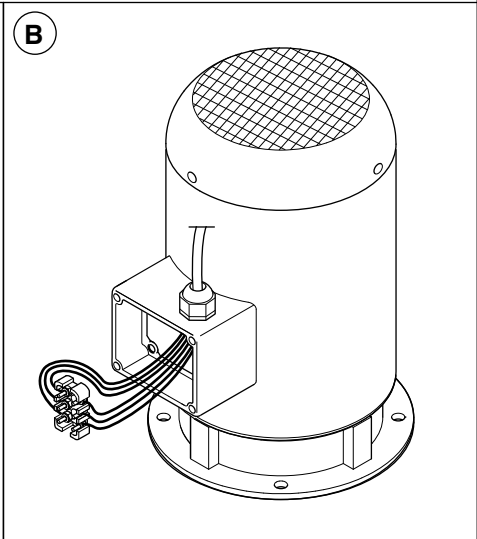
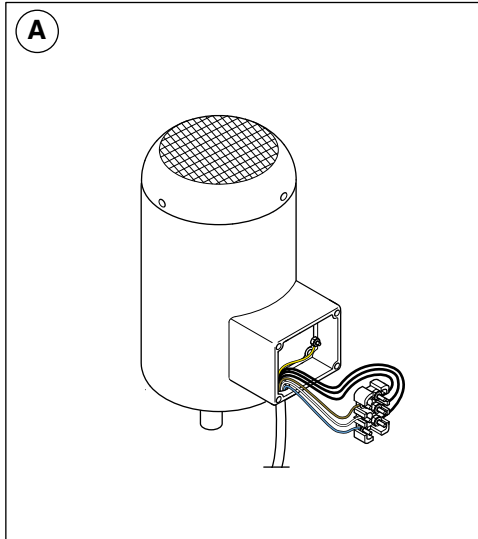
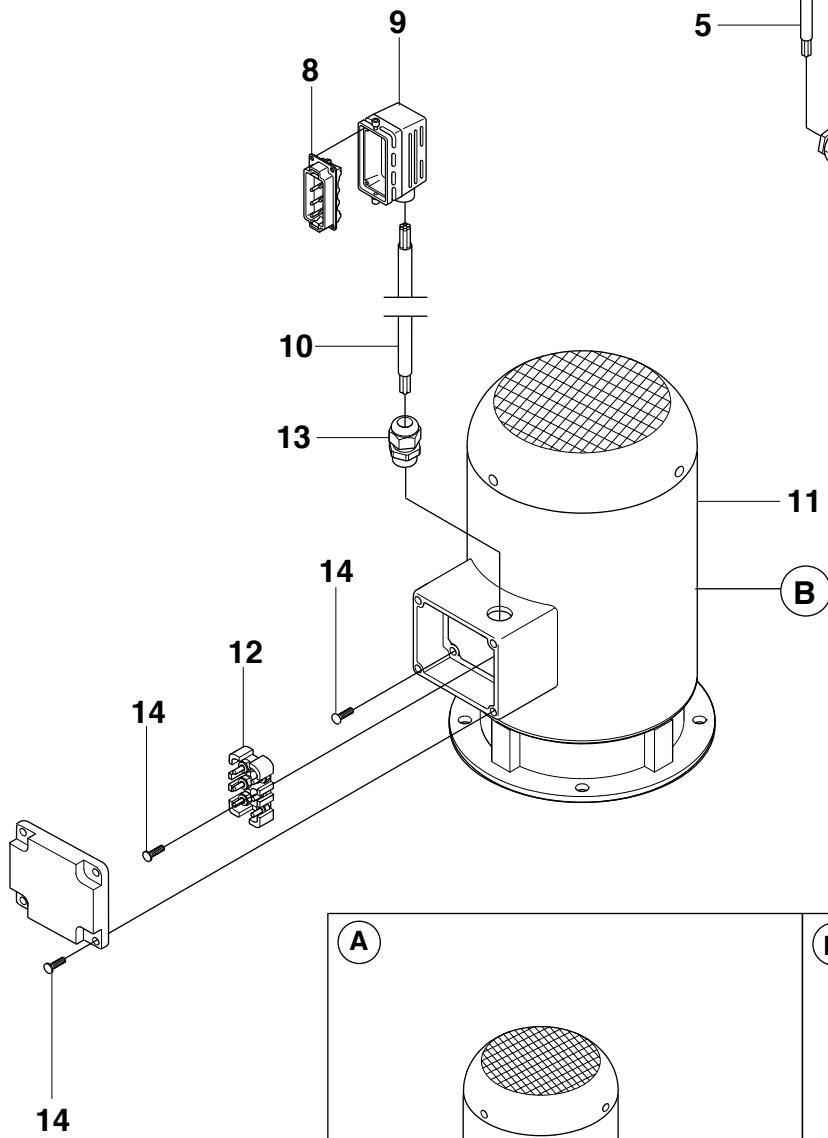
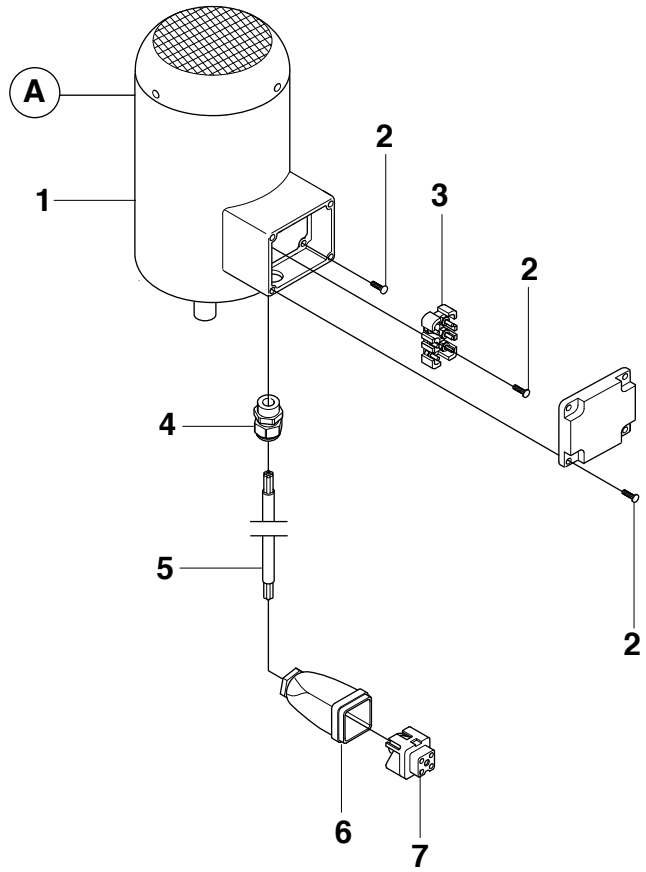
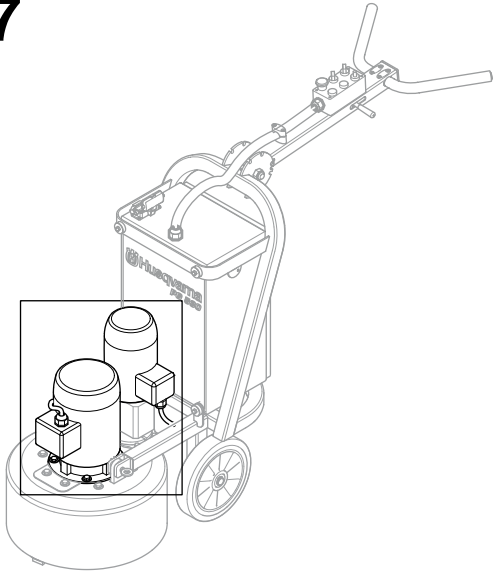

Position	Article	Description	Quantity	Notes	Kit
1	502 55 97-01	MOTOR 0.75 Kw	1		
2	723 13 27-51	SCREW	10		
3	516 06 19-01	TERMINAL BLOCK 1 PHASE	1		
4	516 06 12-01	GLAND	1		
5a	504 75 58-01	CABLE	1	CE	
5b	504 75 58-02	CABLE	1	UL	
6	522 66 13-01	PLUG	1		
7	522 66 15-01	CONNECTOR	1		
8	516 06 14-01	CONNECTOR	1		
9	516 06 13-01	HOOD	1		
10a	522 66 17-01	CE CABLE	1		
10b	522 66 17-02	UL CABLE	1		
11a	502 55 94-01	MOTOR SINGLE PHASE	1		
11b	505 52 32-01	MOTOR 3 PHASE	1		
12a	516 06 19-01	TERMINAL BLOCK 1 PHASE	1		
12b	516 06 20-01	TERMINAL BLOCK 3 PHASE	1		
13a	516 06 12-01	GLAND SINGLE PHASE	1		
13b	516 06 18-01	GLAND 3 PHASE	1		
14a	723 13 27-51	SCREW / SINGLE PHASE	10		
14b	724 13 68-51	SCREW / 3 PHASE	10		