

Disassemble in the order shown. Reassembly is in the reverse order.
 Items 22, 23, 24, 25, 26 should not be disassembled unless being replaced.
 Desarme la herramienta en el orden indicado. Vuelva a armarla en el orden inverso.
 Los artículos 22, 23, 24, 25 y 26 no se deben desarmar a menos que se vayan a reemplazar.
 Démontez l'outil selon l'ordre indiqué cidessous. L'assemblage se fait dans l'ordre inverse.
 Ne pas démonter les articles 22, 23, 24, 25 et 26 sauf pour les remplacer.

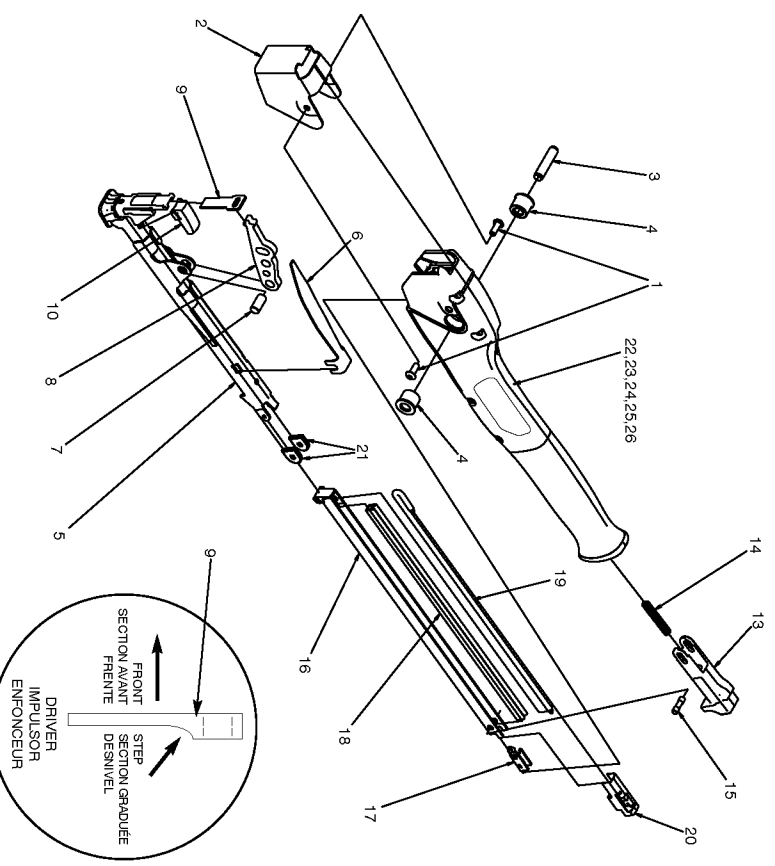

Parts List for PC2K Type 0

Item Number	Part Number	Description	Qty Required
1	108120	COVER PLATE SCREW	2
2	166929	COVER PLATE	1
3	108124	MAIN PIVOT PIN	1
4	108121	CRANK BEARING	2
5	166930	MAGAZINE ASSEMBLY	1
6	166931	RETURN SPRING	1
7	108123	PIN-CRANK	1
8	108135	CRANK	1
9	108122	DRIVER	1
10	166932	BUMPER	1
13	108115	LATCH	1
14	108116	SPRING-COMPRESSION (1
15	108117	LATCH PIVOT PIN	1
16	166933	CORE ASSEMBLY	1
17	108118	RETAINER	1
18	110121	SPRING CUSHION	1
19	108113	SPRING-EXTENSION-PC1	1
20	166934	PUSHER	1
21	108132	BEARING	2
22	108128	GRIP	1
23	108126	FRAME SCREW	6
24	166935	HOUSING-LEFT	1
25	166936	HOUSING-RIGHT	1
26	108445	BUMPER-CRANK	1