

## PNEUMATIC TOOL PARTS LIST

■ CONCRETE NAILER

1990-7-10

Model NC 65AB

NC 65AB(E2)

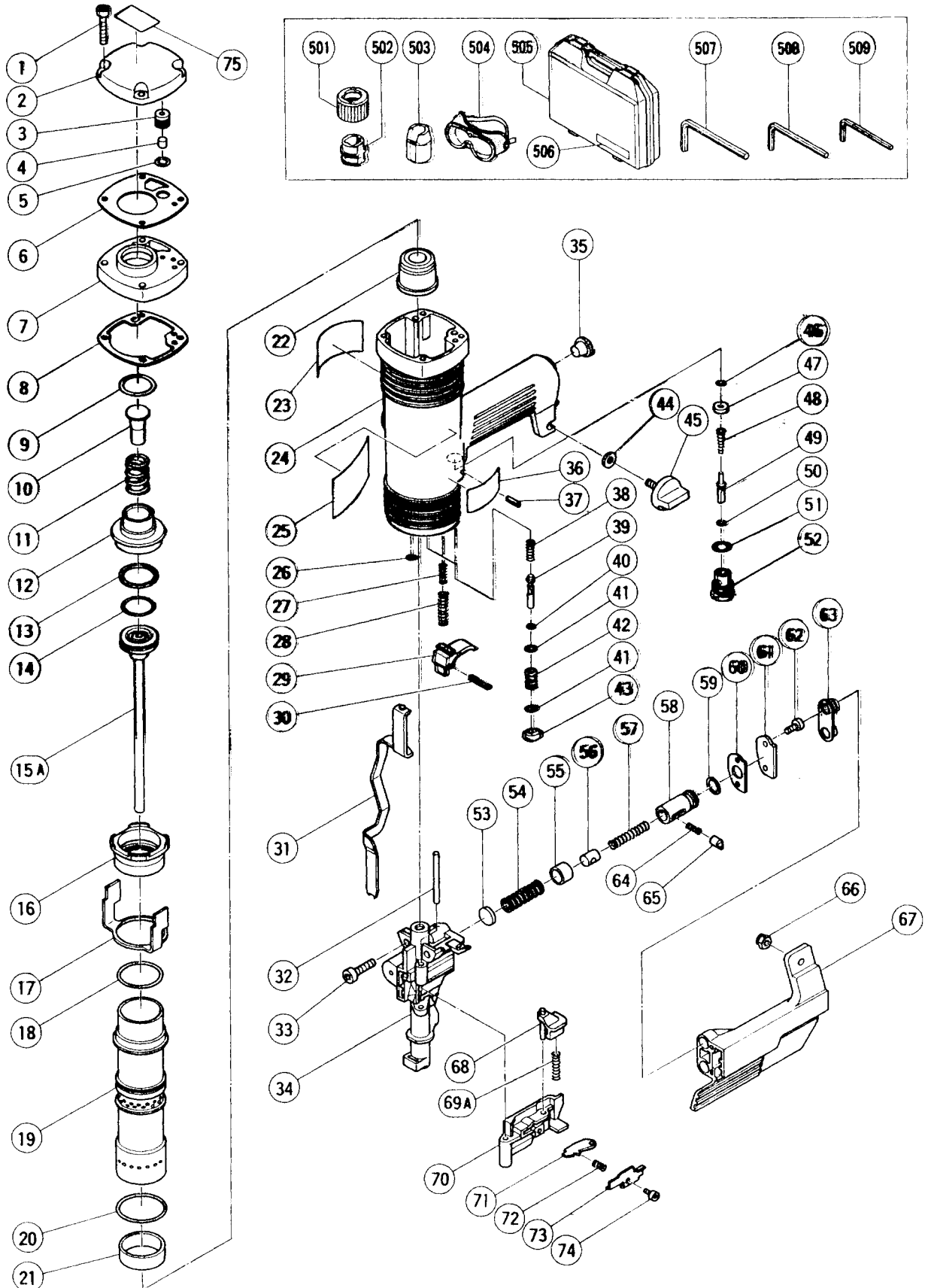

## PARTS

NC 65AB

ITEM NO.	CODE NO.	DESCRIPTION	NO. USED	REMARKS
1	949-664	HEX. SOCKET HD. BOLT M5X30 (10 PCS.)	4	
2	878-805	TOP COVER	1	
3	878-780	VALVE (AUTOMATIC FEED)	1	
4	878-781	VALVE DAMPER	1	
5	987-105	O-RING (S-10)	1	
6	878-778	PACKING (A)	1	
7	878-804	HEAD COVER	1	
8	878-779	PACKING (B)	1	
9	878-783	HEAD VALVE O-RING	1	
10	878-796	HEAD DAMPER	1	
11	878-784	HEAD VALVE SPRING	1	
12	878-782	HEAD VALVE	1	
13	878-777	PISTON RING	1	
14	873-731	O-RING (S-28)	1	
15A	878-776	PISTON	1	
16	878-785	CYLINDER SLEEVE	1	
17	878-797	CYLINDER GUIDE	1	
18	980-717	O-RING (S-38)	1	
19	878-773	CYLINDER	1	
20	996-363	O-RING (S-40)	1	
21	878-775	CYLINDER RING	1	
22	878-774	PISTON DAMPER	1	
23		NAME PLATE	1	
24	878-803	BODY	1	
25		HITACHI LABEL	1	
26	874-436	O-RING (P-4)	1	
27	878-795	SPRING (B)	1	
28	878-792	SPRING	1	
29	878-769	TRIGGER	1	
30	949-864	ROLL PIN D3X22 (10 PCS.)	1	
31	878-801	PUSHING LEVER	1	
32	878-751	PIN	1	
33	985-479	SEAL LOCK HEX. SOCKET HD. BOLT M8X25	2	
34	878-750	TAIL COVER	1	
35	872-035	DUST CAP	1	
36		CAUTION PLATE (A)	1	
37	878-791	ROLL PIN D2.5X12	2	
38	878-790	PLUNGER SPRING (B)	2	
39	878-789	PLUNGER (B)	2	
40	878-607	PLUNGER O-RING	2	
41	997-218	O-RING (S-6)	4	
42	878-788	VALVE BUSHING (C)	2	
43	878-787	KNOB	2	
44	949-432	BOLT WASHER M6 (10 PCS.)	1	
45	878-771	KNOB BOLT M6X18	1	
46	873-093	O-RING (1AP-3)	1	
47	877-703	VALVE BUSHING (B)	1	
48	877-704	PLUNGER SPRING	1	
49	878-786	PLUNGER	1	
50	877-705	PLUNGER O-RING	1	
51	875-638	O-RING (S-12)	1	
52	878-800	VALVE BUSHING (A)	1	

