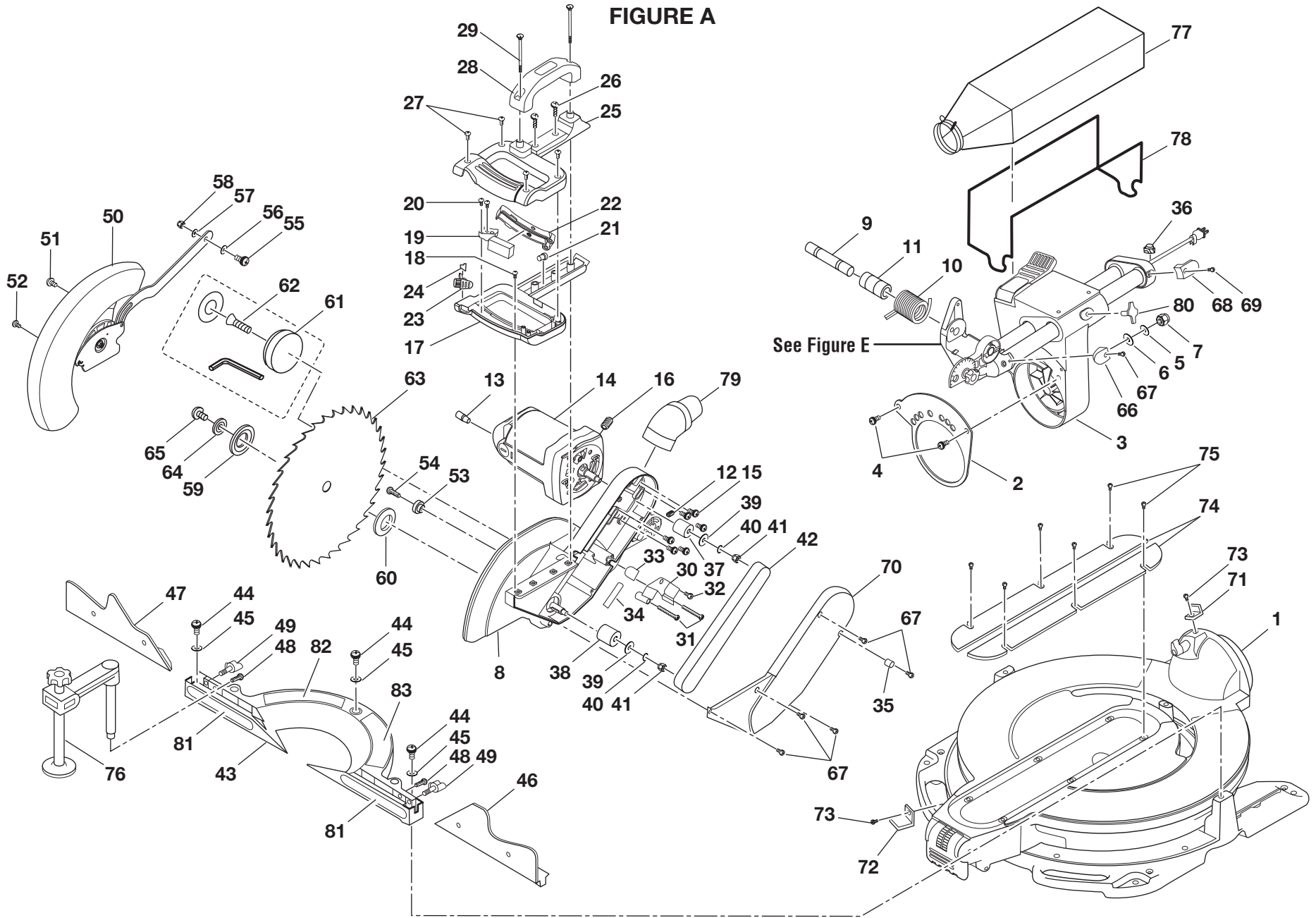

FIGURE A



## RIDGID 12 in. SLIDING COMPOUND MITER SAW – MODEL NUMBER MS1290LZ1

The model number will be found on a plate attached to the motor housing. Always mention the model number in all correspondence regarding your **MITER SAW** or when ordering repair parts.

### PARTS LIST FOR FIGURE A

Key No.	Part Number	Description	Qty.	Key No.	Part Number	Description	Qty.
1	830122	BASE/TABLE ASSEMBLY.....	1	24	828061	TORSION SPRING .....	1
2	830008	BEVEL SCALE .....	1	25	830039	UPPER HANDLE.....	1
3	089100301002	PIVOT ASSEMBLY .....	1	26	830123	SCREW (M5 x 32 mm, SEMS).....	2
4	830009	SCREW (M6 x 1.0-12 mm) .....	2	27	828122	SCREW (M4 x 14 mm, PAN HD.).....	4
5	828117	WASHER.....	1	28	828063	CARRY HANDLE .....	1
6	819179	SPRING WASHER .....	1	29	830123-1	SCREW (M5 x 75 mm, SEMS).....	2
7	818656	LOCK NUT (M12).....	1	30	830035	CORD COVER .....	1
8	089100301004	ARM GUARD ASSEMBLY .....	1	31	830124	SCREW (M5 x 35 mm, PAN HD.).....	2
9	823344	ARM PIVOT SHAFT .....	1	32	816755-3	SCREW (M5 x 0.8-12 mm, PAN CR.) .....	1
10	830131	TORSION SPRING .....	1	33	816725	CORD CLAMP .....	1
11	830111	SPRING SPACER .....	1	34	830264	CORD SLEEVE .....	1
12	828040	SCREW (M6 x 1.0-10 mm, SET LOCK) .....	1	35	830125	CORD CLIP.....	1
13	830023	UP STOP PIN .....	1	36	830148	STRAIN RELIEF .....	1
14	830024	MOTOR ASSEMBLY.....	1	37	830026	MOTOR PULLEY .....	1
15	830025	SCREW (M6 x 16 mm).....	6	38	830033	PINION PULLEY .....	1
16	830164	SCREW (M8 x 25 mm, SET LOCK) .....	1	39	821063	WASHER.....	2
17	830037	LOWER HANDLE.....	1	40	813303-7	LOCK WASHER (M8).....	2
18	813312	SCREW (M4 x 0.7-10 mm, PAN CR.) .....	1	41	820236-7	HEX NUT (M8 x 1.25 mm) .....	2
19	089100303004	SWITCH.....	1	42	830034	BELT (POLY VEE).....	1
20	828122-1	SCREW (M4 x 10 mm, PAN HD.).....	2	43	080017005592	LOWER FENCE (INCL. LABELS).....	1
21	803709-1	WIRE CONNECTOR (#12-#18).....	1	44	830129	SCREW (M8 x 1.25-20 mm, SOC CAP) .....	3
22	828059	SWITCH ACTUATOR.....	1	45	821063-6	WASHER.....	3
23	828060	LOCK BUTTON .....	1	46	830005	RIGHT SLIDING FENCE .....	1

## RIDGID 12 in. SLIDING COMPOUND MITER SAW – MODEL NUMBER MS1290LZ1

The model number will be found on a plate attached to the motor housing. Always mention the model number in all correspondence regarding your **MITER SAW** or when ordering repair parts.

### PARTS LIST FOR FIGURE A (CONT.)

Key No.	Part Number	Description	Qty.	Key No.	Part Number	Description	Qty.
47	830006	LEFT SLIDING FENCE.....	1	67	830124-2	SCREW (M5 x 14 mm, PAN HD.).....	6
48	820244-6	SCREW (M6 x 1.0-20 mm, PAN HD.) .....	2	68	830017	REAR CORD WRAP .....	1
49	830004	FENCE LOCK KNOB .....	2	69	830124-3	SCREW (M5 x 20 mm, PAN HD.).....	1
50	830040	LOWER GUARD ASM.....	1	70	830036	BELT COVER .....	1
51	821873	SCREW (10-32 x 1/2 in., SHOULDER) .....	1	71	829994	BEVEL INDICATOR.....	1
52	020123008	SCREW (10-32 x 1/2 in., PAN HD.).....	1	72	829995	MITER INDICATOR .....	1
53	827498	RUBBER SLEEVE.....	1	73	830130-1	SCREW (M4 x 8 mm, SEMS PN CR L+F WASH) .....	2
54	821878	SCREW (10-32 x 7/8 in., SHOULDER) .....	1	74	829989	TABLE INSERT .....	2
55	089100303005	SCREW (M6 x 22 mm, SHOULDER) .....	1	75	816755-10	SCREW (M5 x 0.8-8 mm, PAN CR.) .....	6
56	821063-1	WASHER.....	1	76	830079	CLAMP ASSEMBLY.....	1
57	820238-5	WASHER.....	1	77	830077	DUST BAG ASSEMBLY .....	1
58	817449-1	LOCK NUT (M6 x 1.0).....	1	78	830076	DUST BAG FRAME .....	1
59	830524	BLADE COLLAR (OUTER) .....	1	79	830078	DUST ELBOW .....	1
60	830526	BLADE COLLAR (INNER) .....	1	80	830015	SLIDE LOCK KNOB.....	1
61	880062	EXACTLINE LASER AND SCREW .....	1	81	867226000	FENCE LABEL .....	2
62	830522	LASER SCREW (M10 x 26 mm) .....	1	82	867226010	FENCE WARNING LABEL (RIGHT) .....	1
63	830000	BLADE .....	1	83	867226004	FENCE WARNING LABEL (LEFT).....	1
64	830523	BLADE WASHER .....	1		983000964	OPERATOR'S MANUAL	
65	830525	ARBOR SCREW (M10 x 20 mm) .....	1		8-13-09		
66	830016	FRONT CORD WRAP .....	1		(REV:06)		

FIGURE B

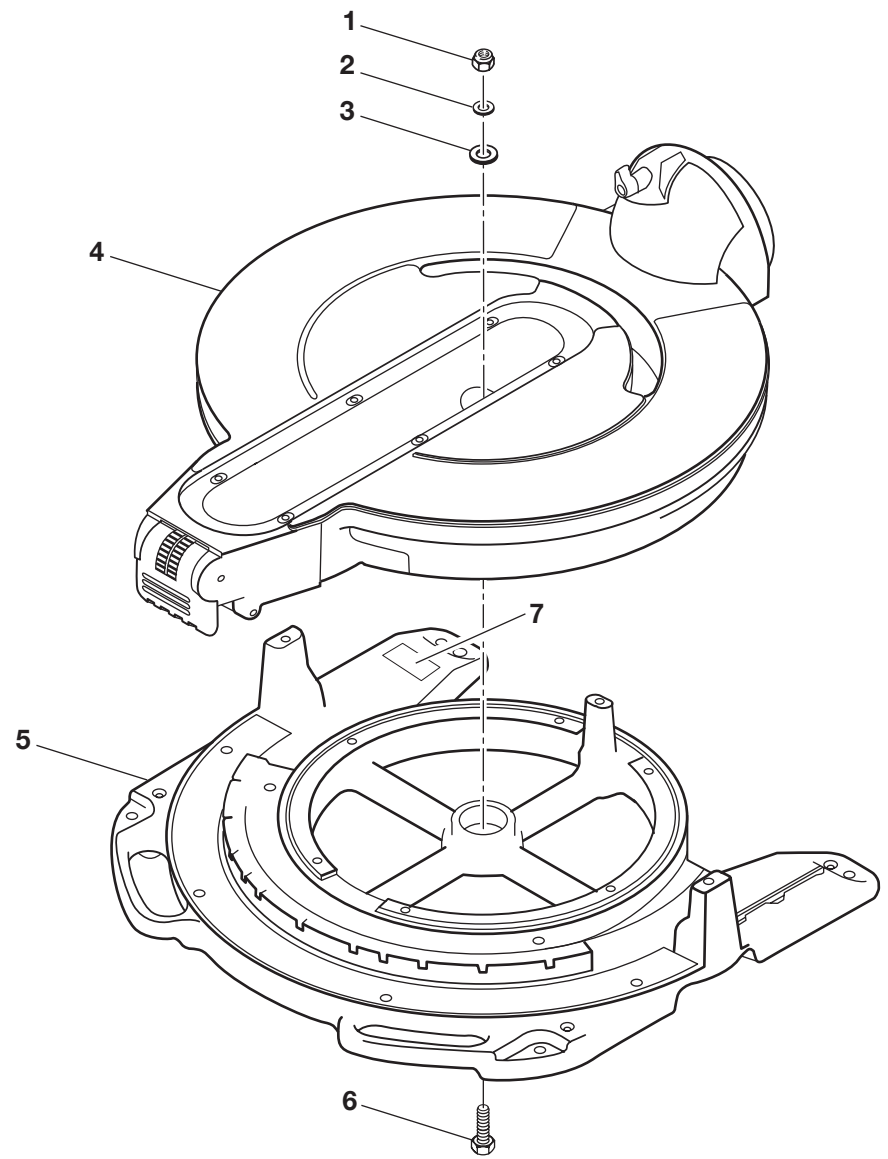

**RIDGID 12 in. SLIDING COMPOUND MITER SAW – MODEL NUMBER MS1290LZ1**

The model number will be found on a plate attached to the motor housing. Always mention the model number in all correspondence regarding your **MITER SAW** or when ordering repair parts.

**PARTS LIST FOR FIGURE B**

<b>Key No.</b>	<b>Part Number</b>	<b>Description</b>	<b>Qty.</b>
1	818656	LOCK NUT (M12).....	1
2	830137	WASHER.....	1
3	830138	WASHER.....	1
4	829981	TABLE ASSEMBLY .....	1
5	830136	BASE ASSEMBLY.....	1
6	822072	SCREW (M12 x 1.75-40 mm, HEX HD.) .....	1
7	089100301005	DATA PLATE LABEL.....	1

FIGURE C

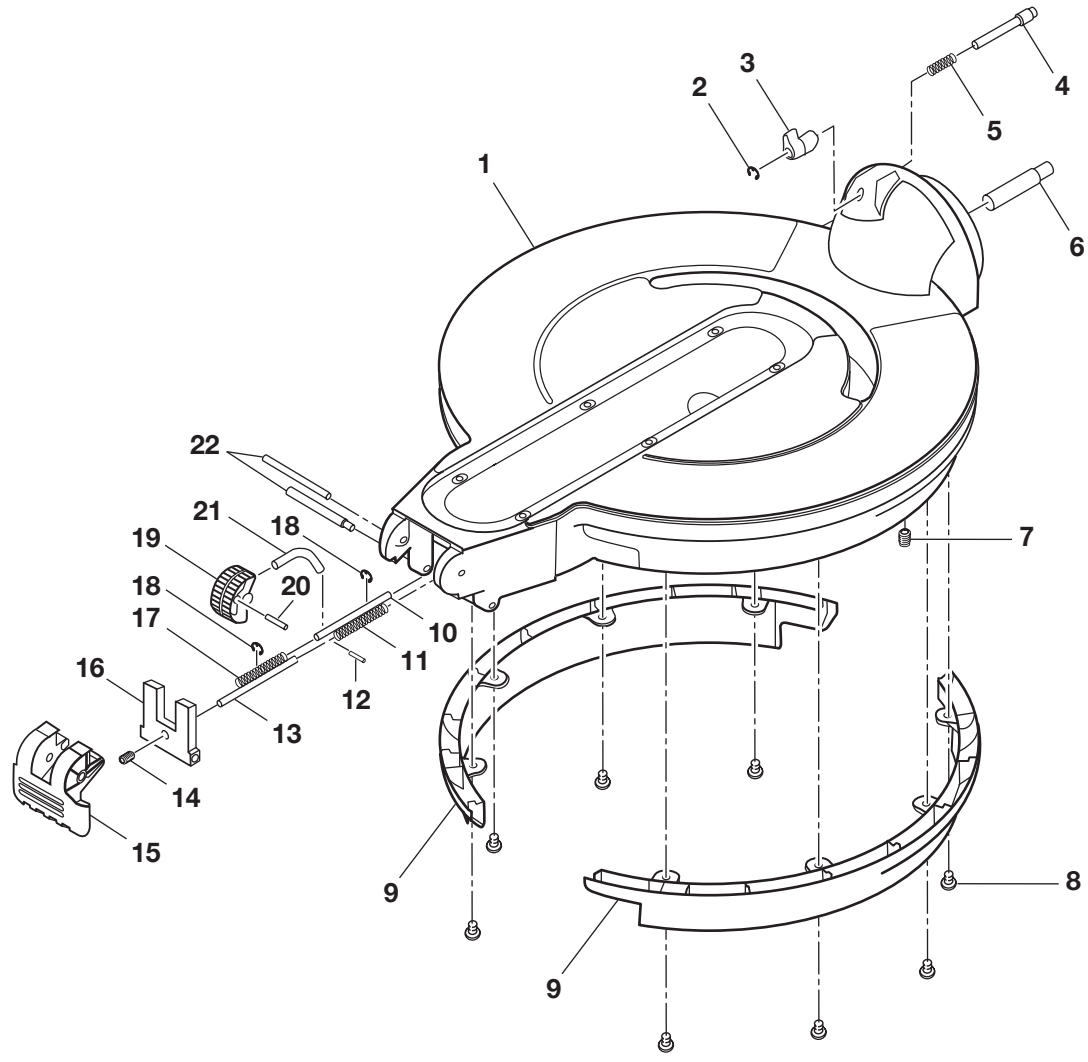

## RIDGID 12 in. SLIDING COMPOUND MITER SAW – MODEL NUMBER MS1290LZ1

The model number will be found on a plate attached to the motor housing. Always mention the model number in all correspondence regarding your **MITER SAW** or when ordering repair parts.

### PARTS LIST FOR FIGURE C

Key No.	Part Number	Description	Qty.
1	830280	TABLE ASSEMBLY .....	1
2	829984-1	RETAINING RING .....	1
3	829992	BEVEL INDEX LEVER .....	1
4	829990	BEVEL INDEX PIN .....	1
5	829991	SPRING .....	1
6	028307009	PIVOT SHAFT .....	1
7	827449-1	SCREW (M8 x 1.25-10 mm, SET LOCK) .....	1
8	820244-2	SCREW (M6 x 1.0-10 mm, PAN HD.) .....	8
9	829982	TABLE SKIRT .....	2
10	830044	MITER INDEX PIN .....	1
11	829983	SPRING .....	1
12	830141	ROLL PIN .....	1
13	829985	MITER LOCK PIN .....	1
14	827449	SCREW (M8 x 1.25-16 mm, SOC SET LOCK) .....	1
15	829988	MITER LOCK LEVER .....	1
16	829986	MITER LOCK PLATE .....	1
17	829983	SPRING .....	1
18	829984	RETAINING RING .....	2
19	830046	MITER INDEX WHEEL .....	1
20	830140	ROLL PIN .....	1
21	830045	MITER INDEX LINK .....	1
22	829987	SCREW (M6 x 8 x 91 mm, SHOULDER) .....	2

FIGURE D

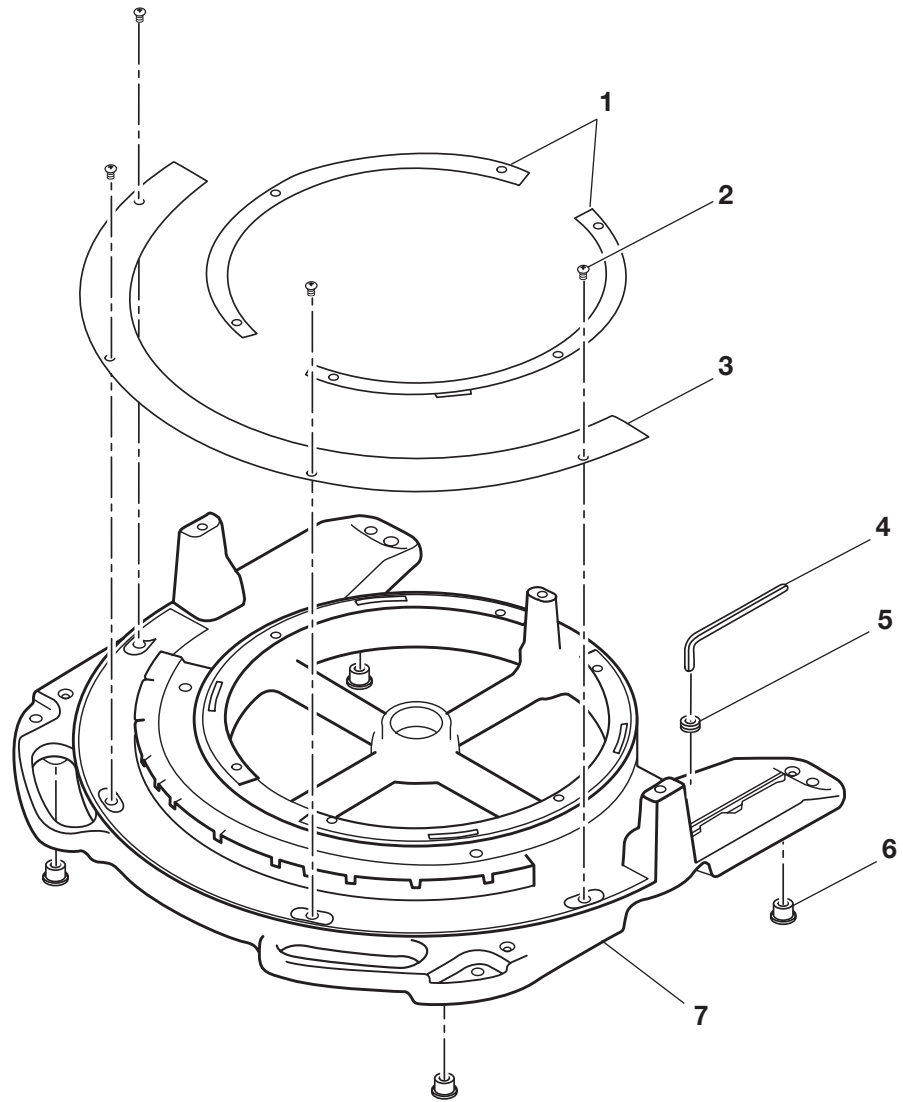



**RIDGID 12 in. SLIDING COMPOUND MITER SAW – MODEL NUMBER MS1290LZ1**

The model number will be found on a plate attached to the motor housing. Always mention the model number in all correspondence regarding your **MITER SAW** or when ordering repair parts.

**PARTS LIST FOR FIGURE D**

<b>Key No.</b>	<b>Part Number</b>	<b>Description</b>	<b>Qty.</b>
1	829997	TABLE SHIM .....	2
2	830166	SCREW (M5 x 0.8-10 mm, FLAT) .....	4
3	829999	MITER SCALE .....	1
4	823492	HEX KEY (1/4 in. x 120 mm).....	1
5	823335	WRENCH GROMMET .....	1
6	829998	RUBBER FOOT .....	4
7	829996	BASE .....	1

FIGURE E

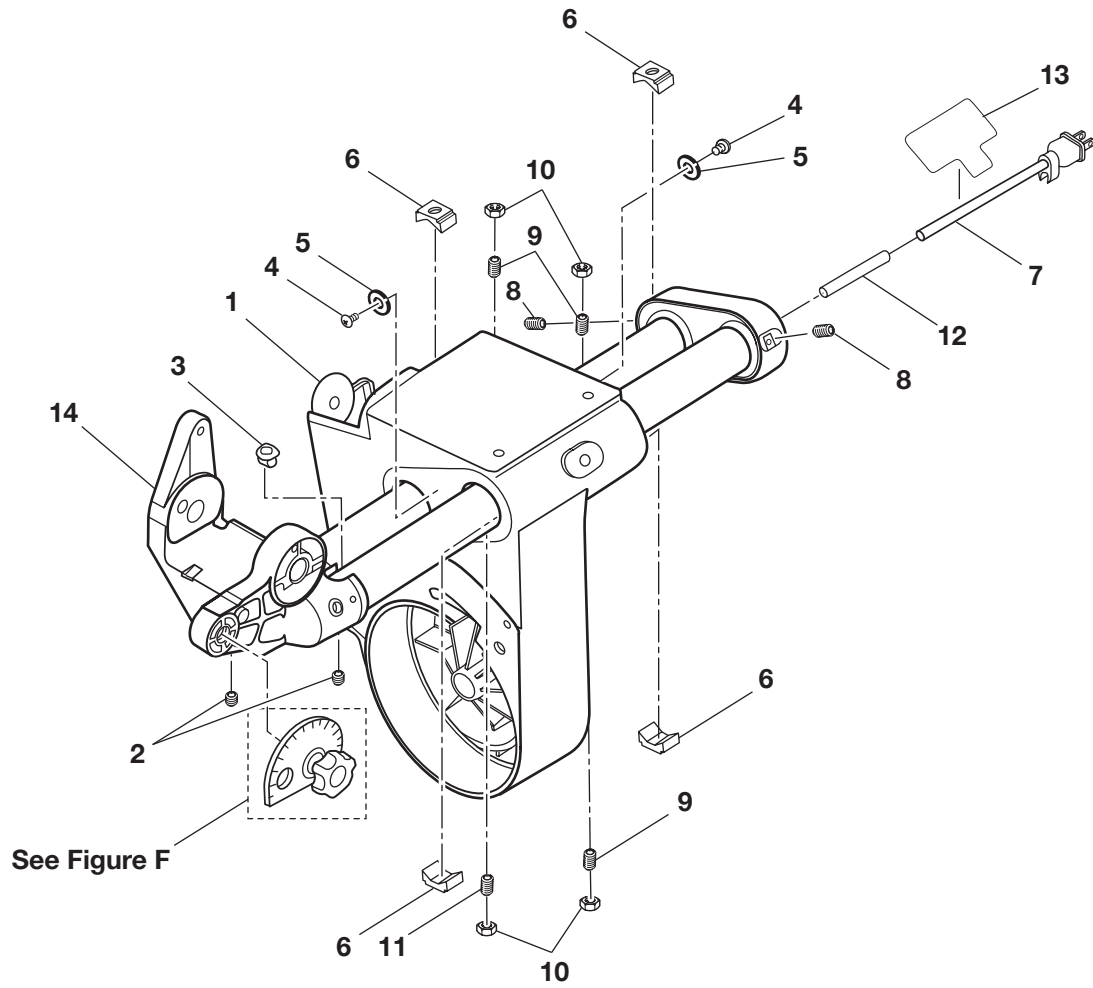

## RIDGID 12 in. SLIDING COMPOUND MITER SAW – MODEL NUMBER MS1290LZ1

The model number will be found on a plate attached to the motor housing. Always mention the model number in all correspondence regarding your **MITER SAW** or when ordering repair parts.

### PARTS LIST FOR FIGURE E

Key No.	Part Number	Description	Qty.
1	830262	PIVOT ASSEMBLY ONLY .....	1
2	830146	SCREW (M8 x 1.25-6 mm, SET LOCK) .....	2
3	830147	CORD GUARD.....	1
4	830145	SCREW (M5 SHOULDER) .....	2
5	830053	RUBBER WASHER.....	2
6	830048	GLIDE TUBE .....	4
7	830038	CORD W/PLUG .....	1
8	830146-1	SCREW (M8 x 1.25-14 mm, SET LOCK) .....	2
9	830144-1	SCREW (M8 x 1.25-20 mm, SET LOCK) .....	3
10	824026-7	HEX NUT (M8 x 1.25 mm) .....	4
11	830144	SCREW (M8 x 1.25-25 mm, SET LOCK) .....	1
12	830264-1	CORD SLEEVE .....	1
13	867226014	WARNING LABEL (FR/SP).....	1
14	089100301001	PIVOT BRACKET .....	1

FIGURE F

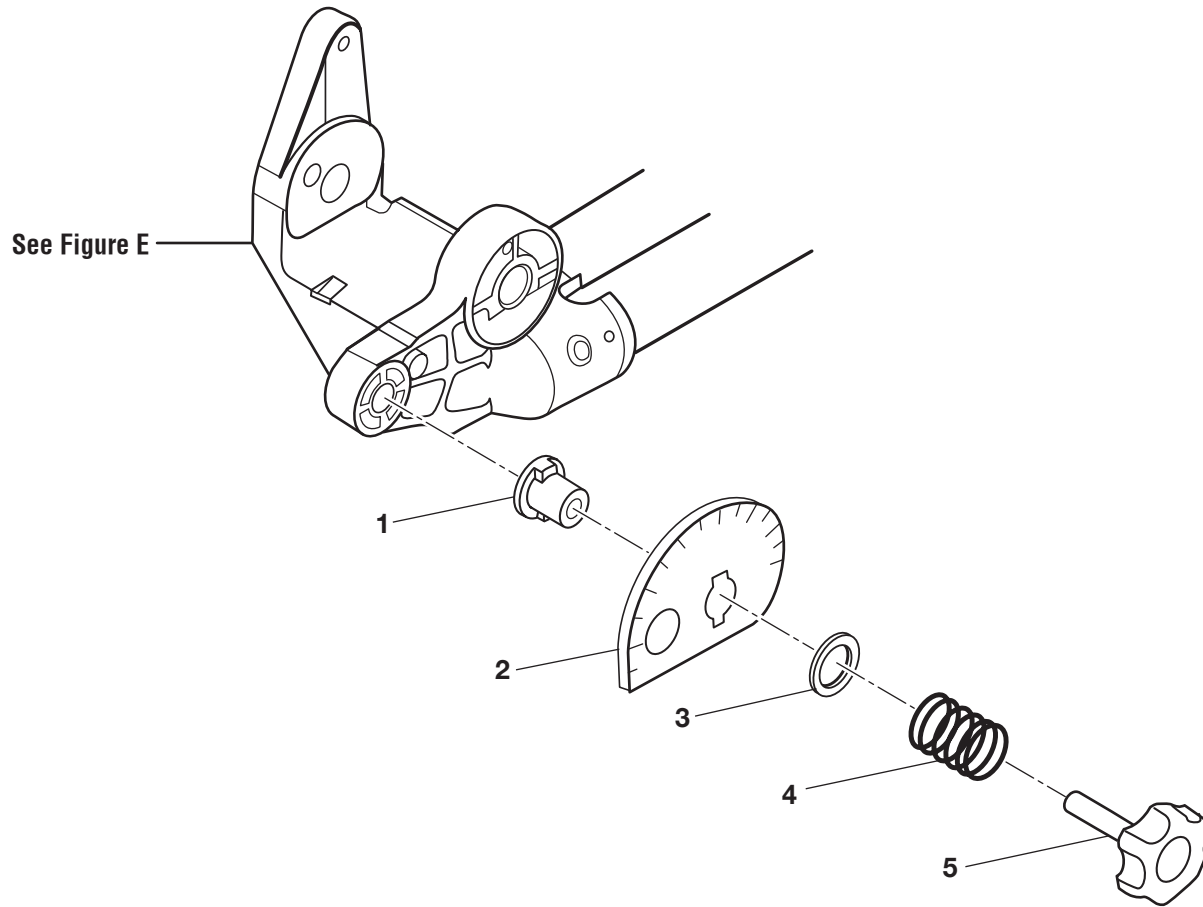

**RIDGID 12 in. SLIDING COMPOUND MITER SAW – MODEL NUMBER MS1290LZ1**

The model number will be found on a plate attached to the motor housing. Always mention the model number in all correspondence regarding your **MITER SAW** or when ordering repair parts.

**PARTS LIST FOR FIGURE F**

<b>Key No.</b>	<b>Part Number</b>	<b>Description</b>	<b>Qty.</b>
1	830018	FLANGE DOWN STOP BEARING .....	1
2	830019	ECCENTRIC PLATE.....	1
3	830149	WASHER.....	1
4	830020	SPRING .....	1
5	830021	DOWN STOP KNOB.....	1

FIGURE G

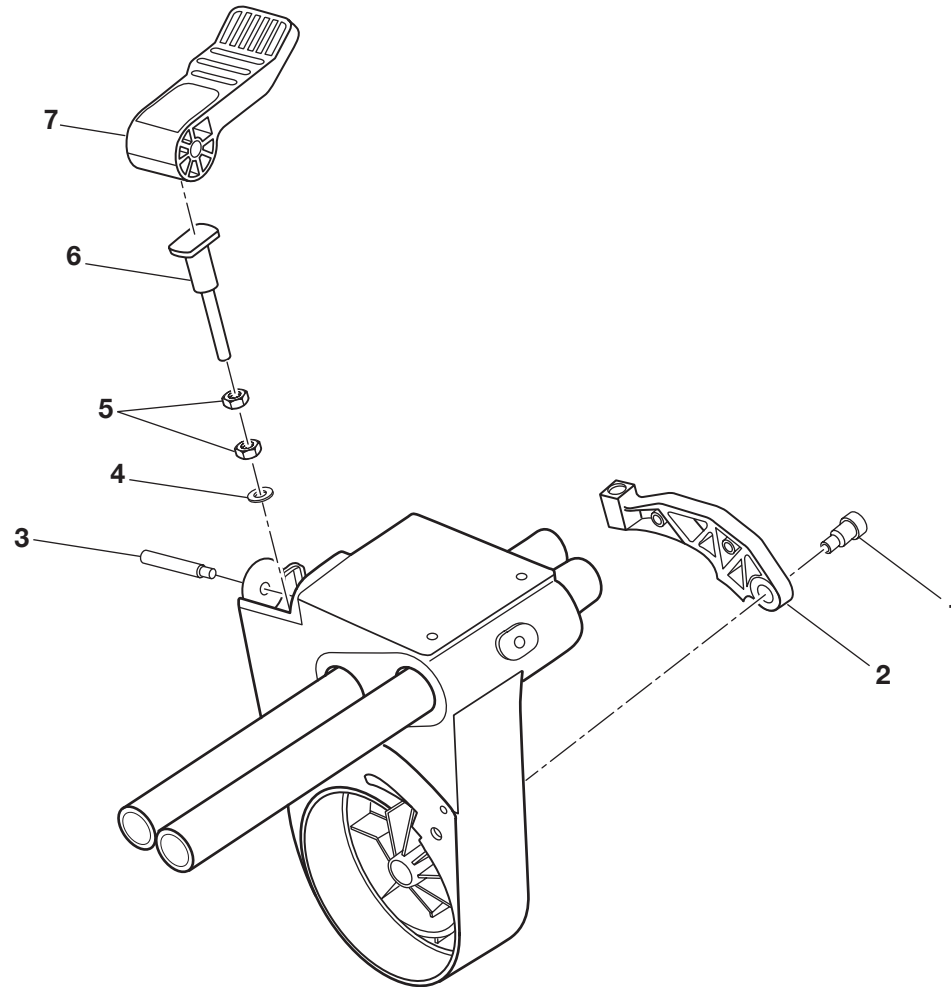

**RIDGID 12 in. SLIDING COMPOUND MITER SAW – MODEL NUMBER MS1290LZ1**

The model number will be found on a plate attached to the motor housing. Always mention the model number in all correspondence regarding your **MITER SAW** or when ordering repair parts.

**PARTS LIST FOR FIGURE G**

<b>Key No.</b>	<b>Part Number</b>	<b>Description</b>	<b>Qty.</b>
1	830151	SCREW (M8, SHOULDER) .....	1
2	830010	BEVEL CLAMP .....	1
3	830011	SCREW (M6 x 1 x 58.5 mm, SHOULDER) .....	1
4	821063-7	WASHER.....	1
5	820236-7	HEX NUT (M8 x 1.25 mm) .....	2
6	830012	BEVEL LOCK PLUNGER.....	1
7	830013	BEVEL LOCK LEVER.....	1

FIGURE H

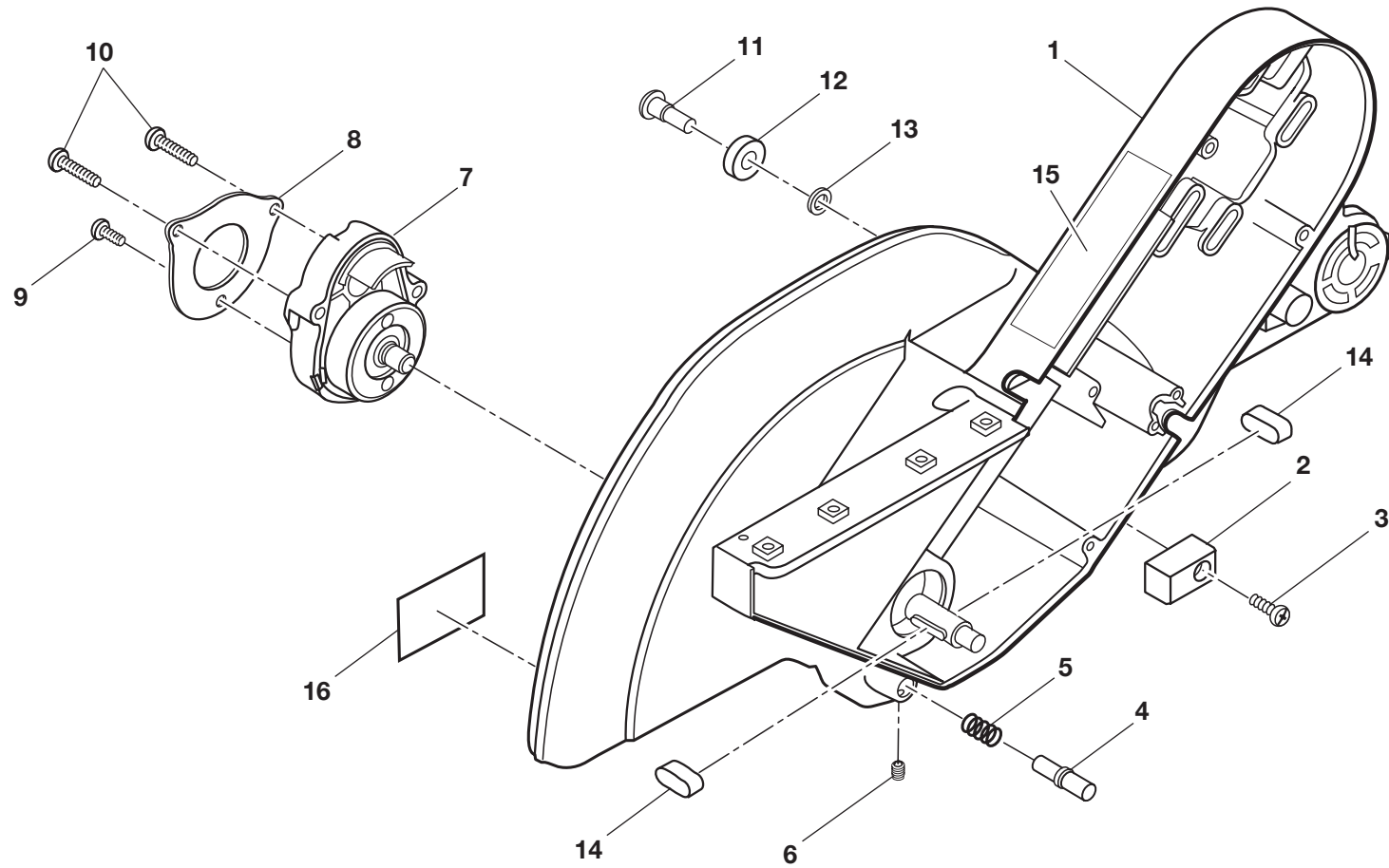



## RIDGID 12 in. SLIDING COMPOUND MITER SAW – MODEL NUMBER MS1290LZ1

The model number will be found on a plate attached to the motor housing. Always mention the model number in all correspondence regarding your **MITER SAW** or when ordering repair parts.

### PARTS LIST FOR FIGURE H

Key No.	Part Number	Description	Qty.
1	089100301003	ARM GUARD .....	1
2	823360	LOWER GUARD BUMPER .....	1
3	816755-6	SCREW (M5 x 0.8-16 mm, PAN HD.) .....	1
4	830029	ARBOR LOCK PIN.....	1
5	830030	SPRING .....	1
6	830155	SCREW (M4 x 5 mm, SET LOCK) .....	1
7	830031-2	ARBOR ASSEMBLY.....	1
8	830032	BEARING RETAINER PLATE .....	1
9	830154-1	SCREW (M5 x 12 mm, SEMS).....	1
10	830154	SCREW (M5 x 25 mm, SEMS).....	2
11	821875-1	SCREW (M6 x 1.0-14 mm, SHOULDER).....	1
12	821862	BEARING GUIDE .....	1
13	820238-2	WASHER.....	1
14	830027	KEY.....	2
15	867226003	OPERATION LABEL.....	1
16	867216027	WARNING LABEL (UPPER GUARD) .....	1

FIGURE I

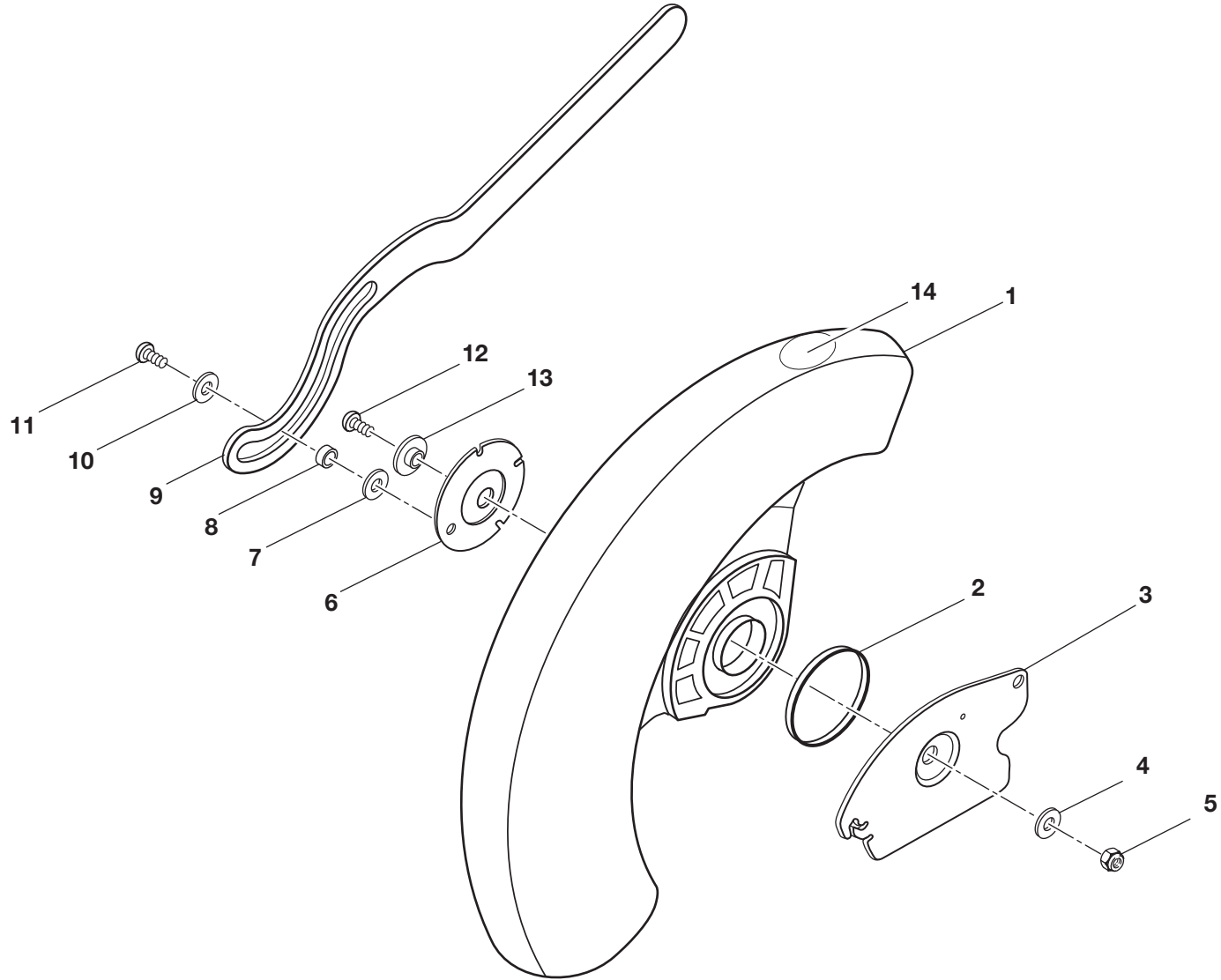

**RIDGID 12 in. SLIDING COMPOUND MITER SAW – MODEL NUMBER MS1290LZ1**

The model number will be found on a plate attached to the motor housing. Always mention the model number in all correspondence regarding your **MITER SAW** or when ordering repair parts.

**PARTS LIST FOR FIGURE I**

<b>Key No.</b>	<b>Part Number</b>	<b>Description</b>	<b>Qty.</b>
1	830530	LOWER GUARD .....	1
2	816677	GUARD SPRING.....	1
3	830529	LOWER GUARD PIVOT .....	1
4	820238-8	WASHER.....	1
5	817449-1	LOCK NUT (M6 x 1.0).....	1
6	826879	GUARD RETAINER .....	1
7	820732-2	WASHER.....	1
8	820725-01	SPACER.....	1
9	830041	ACTUATOR LINK.....	1
10	820732-1	WASHER.....	1
11	820724	SCREW (M5, SHOULDER) .....	1
12	828142	SCREW (M6 x 1.0-13 mm, FLAT HD.) .....	1
13	827409	BEARING RETAINER .....	1
14	867227001	NO HANDS WARNING LABEL .....	1

FIGURE J

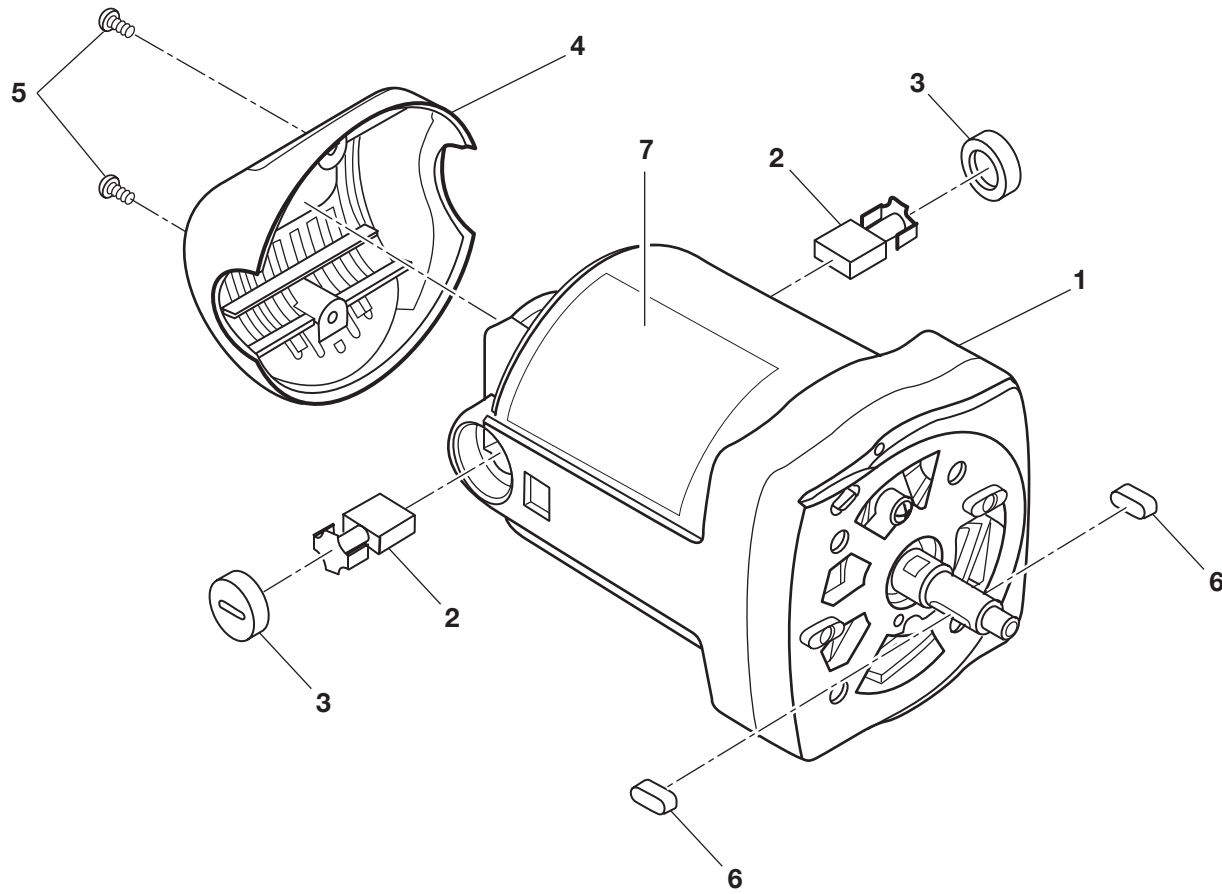

**RIDGID 12 in. SLIDING COMPOUND MITER SAW – MODEL NUMBER MS1290LZ1**

The model number will be found on a plate attached to the motor housing. Always mention the model number in all correspondence regarding your **MITER SAW** or when ordering repair parts.

**PARTS LIST FOR FIGURE J**

<b>Key No.</b>	<b>Part Number</b>	<b>Description</b>	<b>Qty.</b>
1	830253	MOTOR.....	1
2	816768	BRUSH .....	2
3	830250	BRUSH COVER .....	2
4	828064	REAR MOTOR COVER.....	1
5	828122-1	SCREW (M4 x 10 mm, PAN HD).....	2
6	830027	KEY.....	2
7	867226013	WARNING LABEL (ENG.) .....	1