

MK Diamond Products, Inc.

www.mkdiamond.com

MK-1600 Electric Concrete Saw PARTS LIST

Model	Part
MK-1605B 5 Hp Single Phase Premium	168099
MK-1610B 10 Hp Single Phase Premium	168611
MK-1610B 10 Hp Three Phase Premium	167426
MK-1610B 10 Hp Three Phase Premium	167427



MK-1610B Premium
P/N 167427

Revision 102	04.2019
Manual P/N 171200-PM	

Caution: Read all safety and operating instructions before using this equipment. This parts list **MUST** accompany the equipment at all times.

FIGURE 4 MK-1610B PREMIUM 240V 3PH P/N 167426

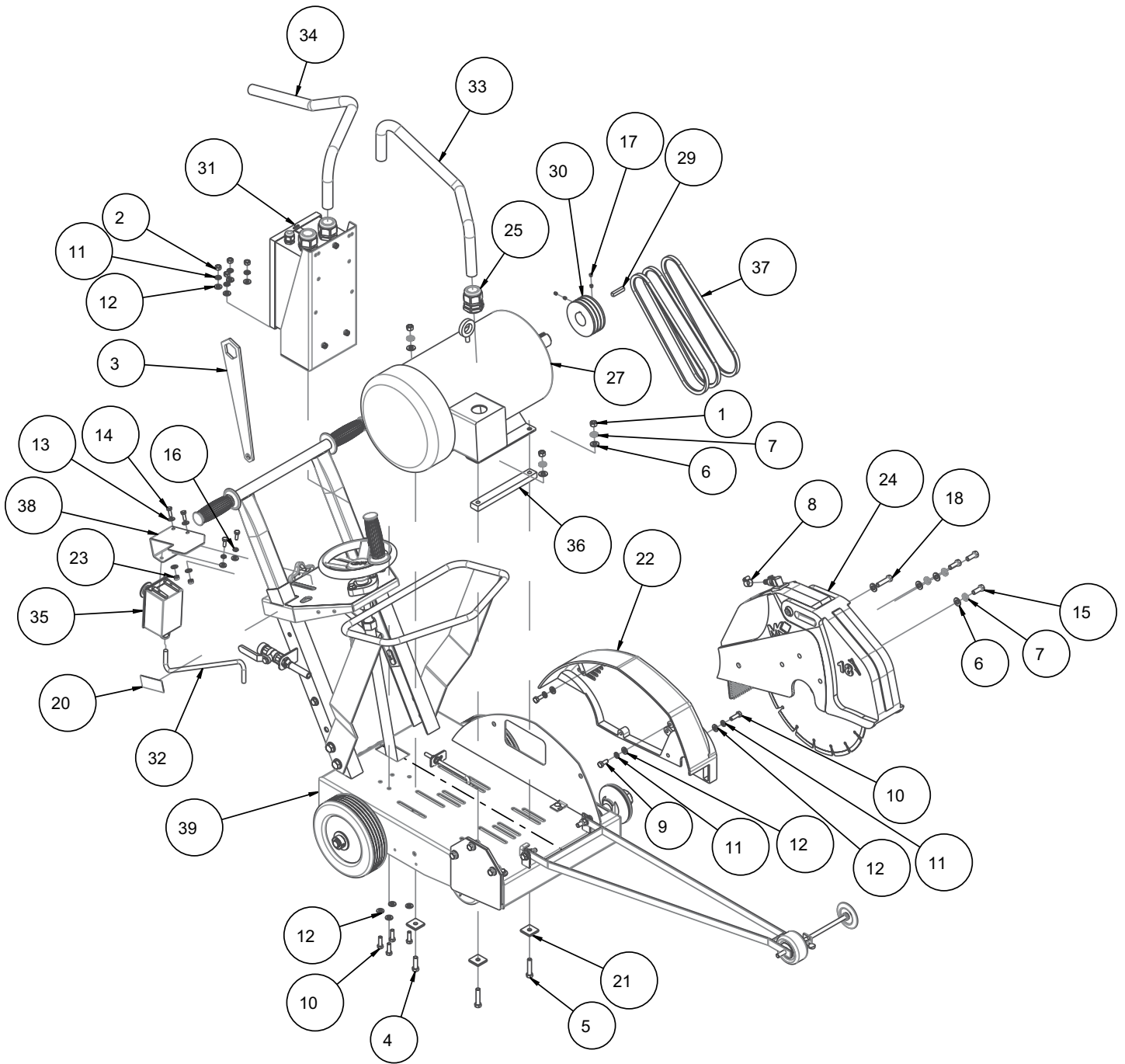

FIGURE 4 MK-1610B PREMIUM 240V 3PH P/N 167426

Item	Description	P/N	Qty
1	NUT, HEX, 3/8 - 16	101188	3
2	NUT, HEX, 5/16 - 18	101196	4
3	WRENCH, BOX END, 1-1/2 X 9/16	137976	1
4	SCREW, 3/8 - 16 X 1-1/4 HEX HEAD CAP	150774	1
5	SCREW, HEX HD, 3/8-16 X 1-3/4	150920	2
6	WASHER, 3/8 SAE FLAT	150923	7
7	WASHER, 3/8 SPLIT LOCK	150925	6
8	CLAMP, HOSE, 5/8	151198	1
9	SCREW, HEX HD, CAP, 5/16-18X3/4	151369	2
10	SCREW, HEX HD, 5/16-18X1	151743	5
11	WASHER, LOCK, SPLIT, 5/16	151747	7
12	WASHER, FLAT, SAE, 5/16	151754	11
13	WASHER, FLAT, SAE, 1/4	151915	6
14	SCREW, HEX HD, 1/4-20X3/4	152370	4
15	SCREW, HEX HD CAP, 3/8-16 X 1	152507	3
16	WASHER, LOCK, SPLIT, 1/4	152591	2
17	SCREW, SET, CUP PT, 5/16-18 X 1/4	152607	4
18	SCREW, 3/8 - 16 X 1-1/2 HEX HEAD	153528	1
19	COIL, STARTER 240V	156209	1
20	TAG, SERIAL NUMBER, BLANK	157500-RW	1
21	WASHER, SQR, 7/16 X 1-1/4 X 3/16	157567	3
22	GUARD, BELT (COMP)	157704	1
23	NUT, HEX, NYLK, 1/4-20	159857	2
24	ASSY, BLADE GUARD, 18"	160481	1
25	CONNECTOR, CORD, LTF29	160689	1
26	ELEMENT, HEATER 25.6-27A 3/SET	160722	1
27	TERMINAL, 8GA X #10 RING	166276	3
28	KEY, 5/16 SQR X 1-1/2	167581	1
29	PULLEY, 3VX X 3 X 3.6 X 1-3/8	167584	1
30	ASSEMBLY, SWITCH, 3 PHASE	168568	1
31	CORD, 18/3 SEOOW 3FT	168571	1
32	CORD, 8/4 SEOOW 4FT	168572	1
33	CORD, 8/4 SEOOW 3.5 FT	168572	1
34	SPACER, MOTOR MOUNT, 10 HP	168621	1
35	BELT, V, 3VX300	170362	3
36	BRACKET, SWITCH	172428	1
37	MK-1610 PREM LESS MTR, 18" BG-SS	172432	1
38	MTR, 10HP 208-230/460V 3PH 1725RPM-COMP	172561	1
39	ASSY, SWITCH BO 3PH BUTTONS	172836-13	1

FIGURE 6 MK-1610 PREMIUM LESS MTR, 18" BG-SS P/N 172432

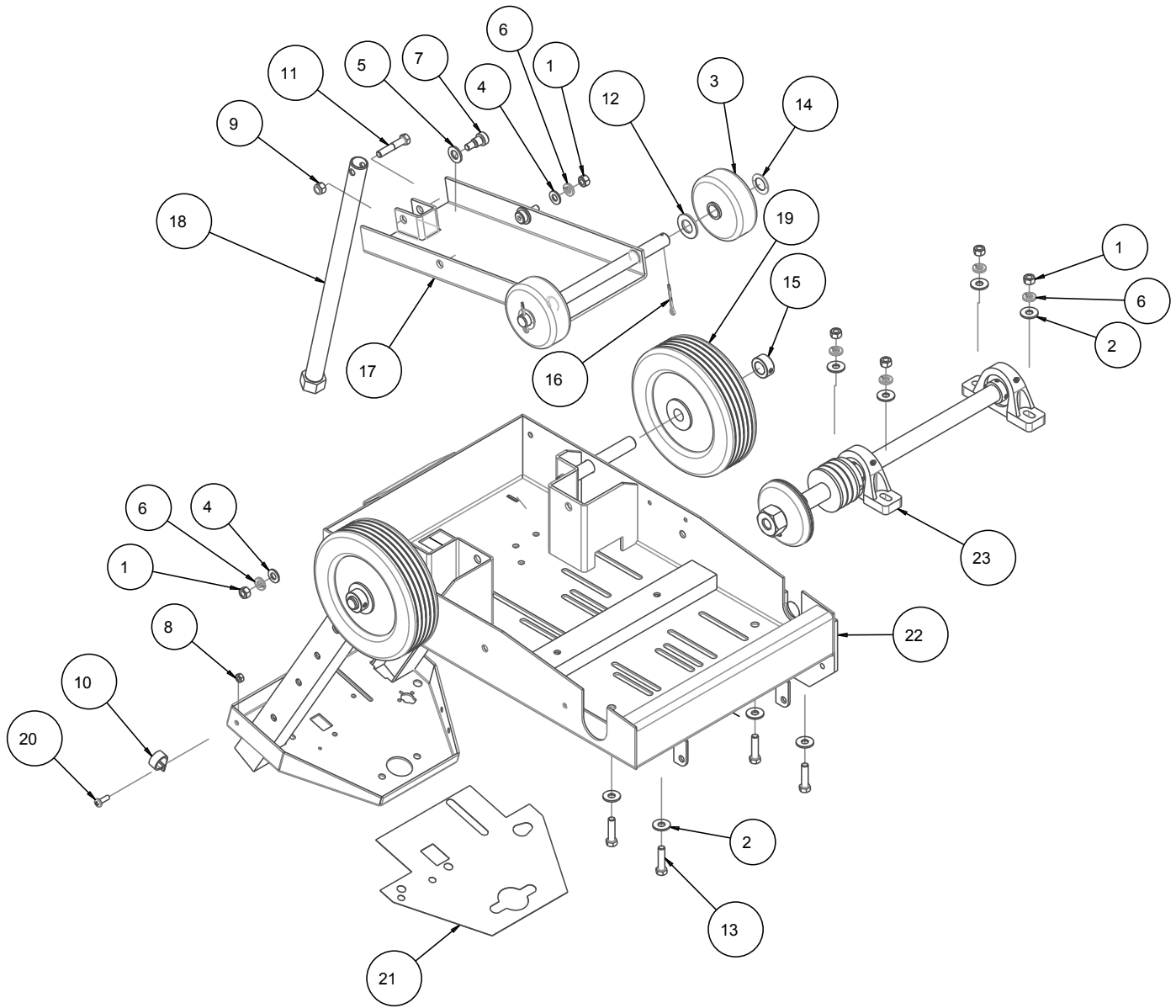

FIGURE 6 MK-1610 PREMIUM LESS MTR, 18" BG-SS P/N 172432

Item	Description	P/N	Qty
1	NUT, 3/8 -16 HEX	101188	6
2	WASHER, FLAT, USS, 3/8	101360	8
3	WHEEL, FRONT, Ø 4 X 1 - 1/2W	150830	2
4	WASHER, 3/8 SAE FLAT	150923	2
5	WASHER, 1/2 SAE FLAT	150924	2
6	WASHER, 3/8 SPLIT LOCK	150925	6
7	SCREW, SHOULDER, 1/2 X 1/2	151753	2
8	NUT, HEX, 14-20	151893	1
9	NUT, 3/8 - 16 NYLOK HEX	152505	1
10	CLAMP, 3/4 CUSHION LOOP	152594	1
11	SCREW, HEX HD CAP 3/8 - 16 X 2	153485	1
12	WASHER, FLAT, SAE, 3/4	153523	2
13	SCREW, 3/8-16 X 1-1/2 HEX HEAD	153528	4
14	SHIM, .045 THK .750 ID 1.250 OD	153699	2
15	COLLAR, SET, 3/4"	153814	2
16	PIN, COTTER 1/8 X 1-1/2	153861	2
17	WELDMENT, TRUCK	155048	1
18	LINKAGE, DEPTH FEED 1600/9000	155049	1
19	WHEEL, REAR 8"	155986	2
20	SCREW, PAN HD, 1/4-20 X 3/4	157523	1
21	LABEL, FRAME CONSOLE	157850	1
22	MAIN FRAME	168369	1
23	ASSY, BLD SHAFT, 10HP	172302	1

FIGURE 6 MK-1610 PREMIUM LESS MTR, 18" BG-SS P/N 172432

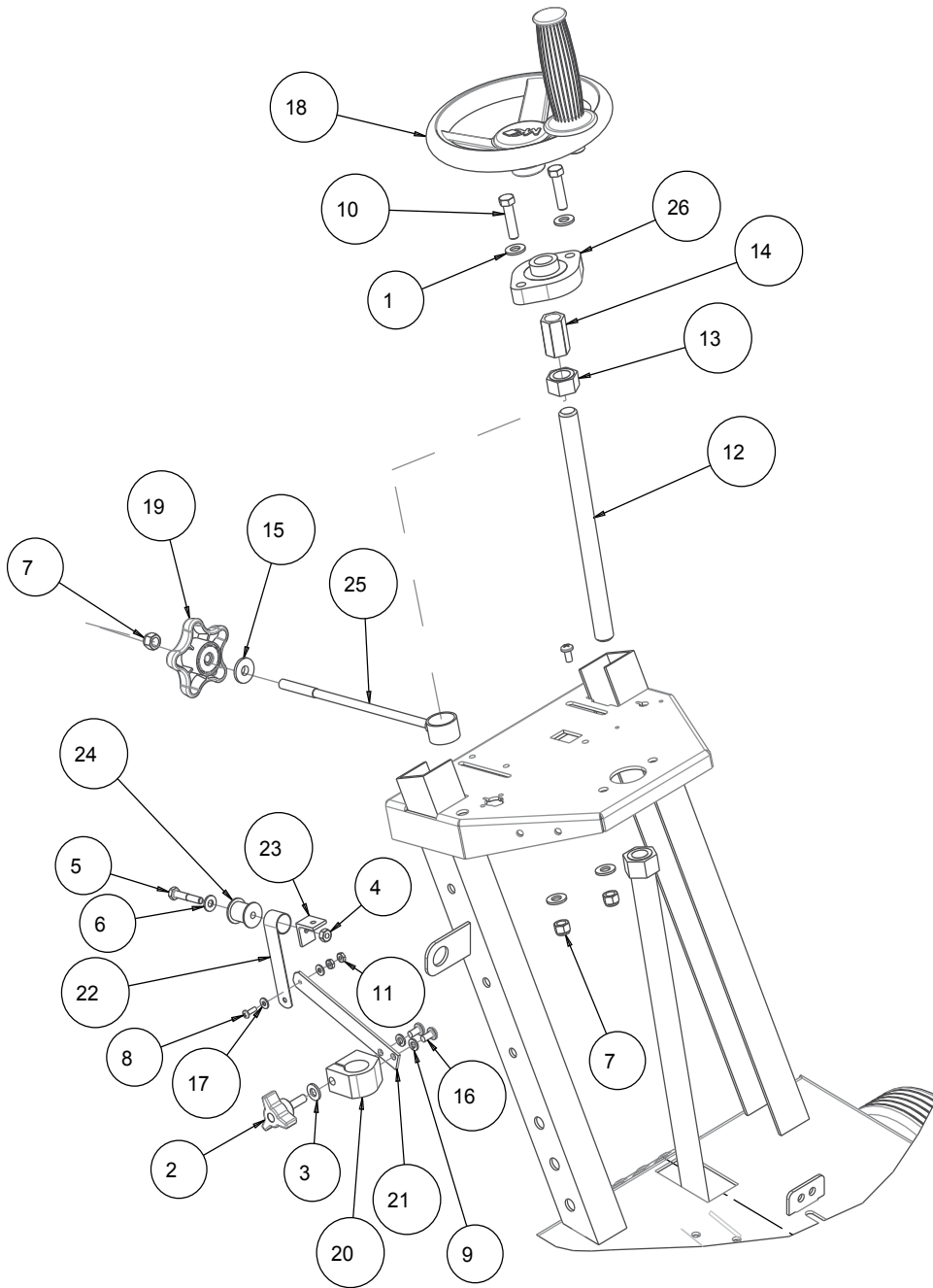

FIGURE 6 MK-1610 PREMIUM LESS MTR, 18" BG-SS P/N 172432

Item	Description	P/N	Qty
1	WASHER, 3/8 SAE FLAT	150923	4
2	KNOB, DAVIES, 5/16 - 18 X 1	151681	1
3	WASHER, FLAT, SAE, 5/16	151754	1
4	NUT, HEX, 1/4 - 20	151893	1
5	SCREW, HEX HEAD 1/4 - 20 X 1 - 1/2"	151914	1
6	WASHER, 1/4 SAE FLAT	151915	1
7	NUT, 3/8 - 16 NYLOK HEX	152505	6
8	SCREW, RND HD, #8 - 32 X 1/2	152517	1
9	WASHER, 1/4 SPLIT LOCK	152591	2
10	SCREW, 3/8-16 X 1-1/2 HEX HEAD	153528	2
11	NUT, HEX, 8-32	153549	2
12	STUD, 3/4 - 10 X 10"	155062	1
13	NUT, 3/4 - 10 HEX	155063	1
14	SPACER, DEPTH CONTROL	155161	1
15	WASHER, THRUST	155238	1
16	SCREW, PAN HD, CAP 1/4 - 20 X 1/2	155452	3
17	WASHER, FLAT, SAE, #8	155454	2
18	ASSY, CRANK WHEEL, 3/4 - 10	155457	1
19	KNOB, ADJ, 5 PRONG COMP	155845	1
20	CLAMP, DEPTH INDICATOR	156603	1
21	ARM, DEPTH INDICATOR	156604	1
22	SPRING, DEPTH GAUGE	156605	1
23	BRACKET, DEPTH INDICATOR	156608	1
24	SPOOL, DEPTH INDICATOR 1"	157845	1
25	LOCK, DEPTH CONTROL, 8-7/8	157846	1
26	BEARING, FLANGE, 3/4ID, FD204	165971	1

FIGURE 6 MK-1610 PREMIUM LESS MTR, 18" BG-SS P/N 172432

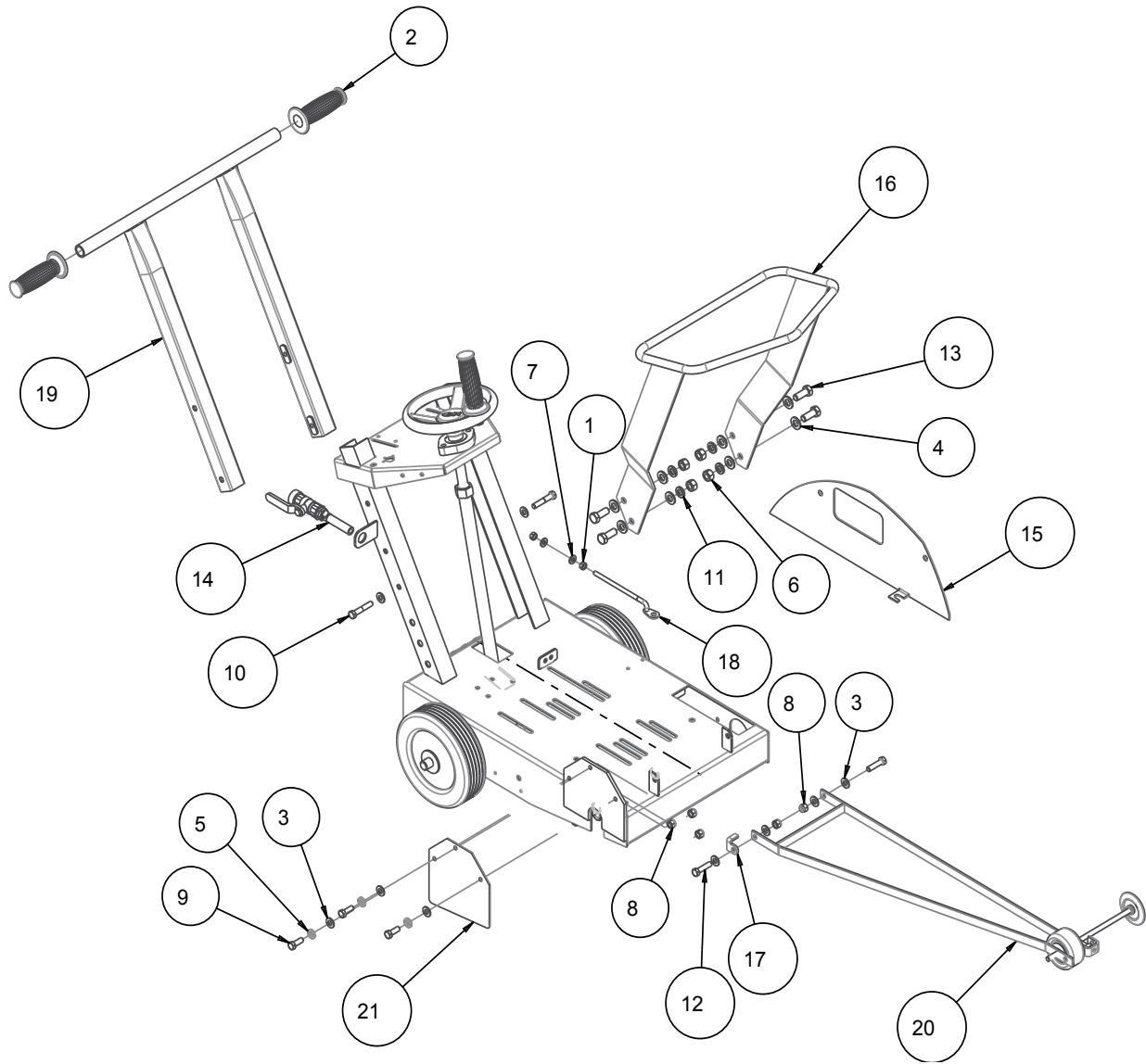
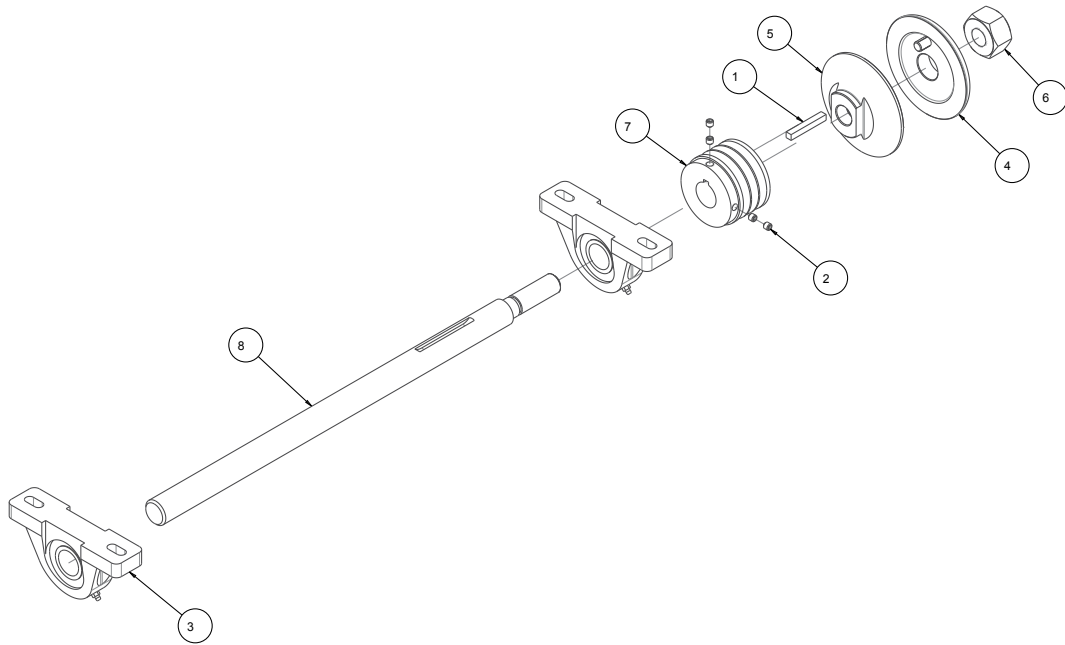

FIGURE 6 MK-1610 PREMIUM LESS MTR, 18" BG-SS P/N 172432

Item	Description	P/N	Qty
1	NUT, HEX, 5/16-18	101196	2
2	GRIP, HANDLE, 1.0 ID	150842	2
3	WASHER, 3/8 SAE FLAT	150923	9
4	WASHER, 1/2 SAE FLAT	150924	8
5	WASH, LOCK, SPLIT, 3/8	150925	3
6	NUT, HEX, 1/2-13	151282	4
7	WASHER, SAE FLAT 5/16	151754	2
8	NUT, 3/8 - 16 NYLOK HEX	152505	5
9	SCREW, HEX HD CAP, 3/8-16X1	152507	3
10	SCREW, HEX HD, CAP, 3/8-16X2	153485	2
11	WASHER, 1/2 SPLIT LOCK	153524	4
12	SCREW, 3/8-16 X 1-1/2 HEX HEAD	153528	2
13	SCREW, 1/2-13 X 1-1/4 HEX HEAD CAP	153532	4
14	ASSY, WATER VALVE	155458	1
15	PLATE, BELT GUARD BACK	157705	1
16	LIFTING BAIL	157745	1
17	CLIP, STOP	157837	1
18	ARM, TENSION	157848	1
19	HANBLEBAR, 9000/1600	159903	1
20	ASSY, POINTER, CONC SAW	166465	1
21	COVER, BLADESHAFT	172421	1

FIGURE 8 ASSY, BLD SHAFT, 10HP P/N 172302



Item	Description	P/N	Qty
1	KEY, 1/4 SQR X 1-3/4	150796	1
2	SCREW, SET, CUP PT, 5/16-18 X 1/4	152607	4
3	BEARING, PILLOW BLK 1:	155072	2
4	ASSY, OUTER FLANGE, 4"	155451	1
5	FLANGE, 4.0 X 3/4-16RH INNER	157843	1
6	NUT, BLD SHFT, 3/4-16	157844	1
7	PULLEY, 3VX X 3 X 2.65 X 1	160614	1
8	SHAFT, BLADE, -SS	172301	1

FIGURE 9 ASSY, POINTER, CONC SAW P/N 166465

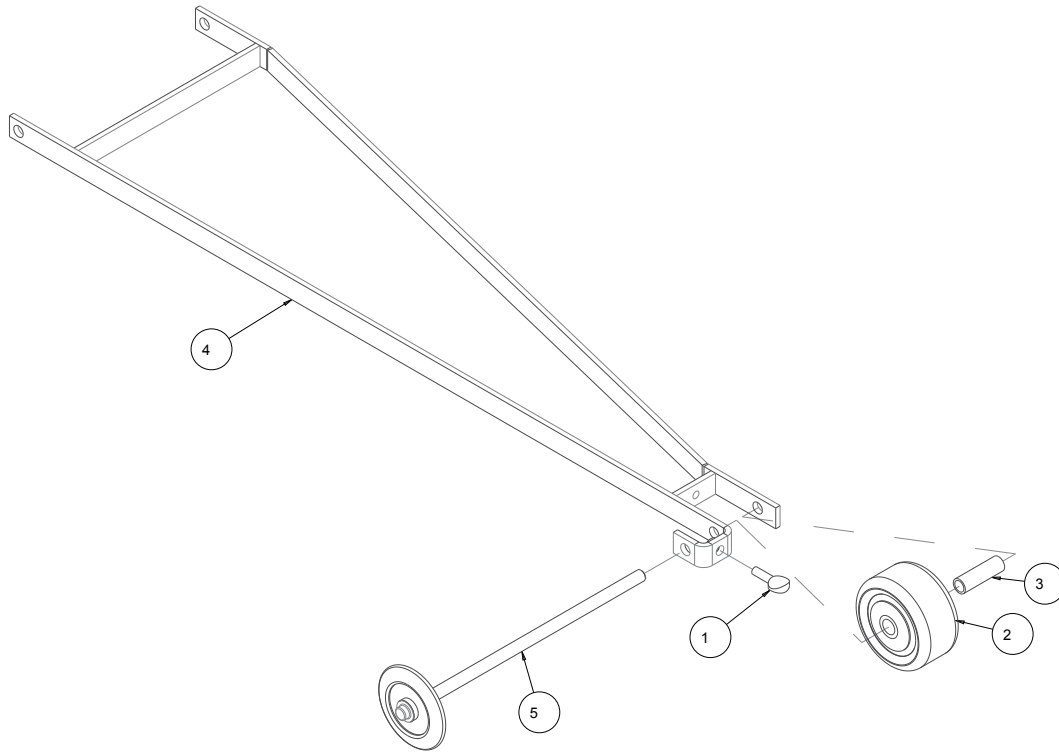

Item	Description	P/N	Qty
1	SCREW, THUMB 1/4-20 X 3/4	150991	1
2	WHEEL, POINTER, 3"	155066	1
3	BUSHING, 3/8ID X 1-5/8L	155153	1
4	POINTER ARM, MK-1600	156544	1
5	ASSY, POINTER WHEEL	165238	1

FIGURE 10 ASSY, BLD GUARD, 18" P/N 160481

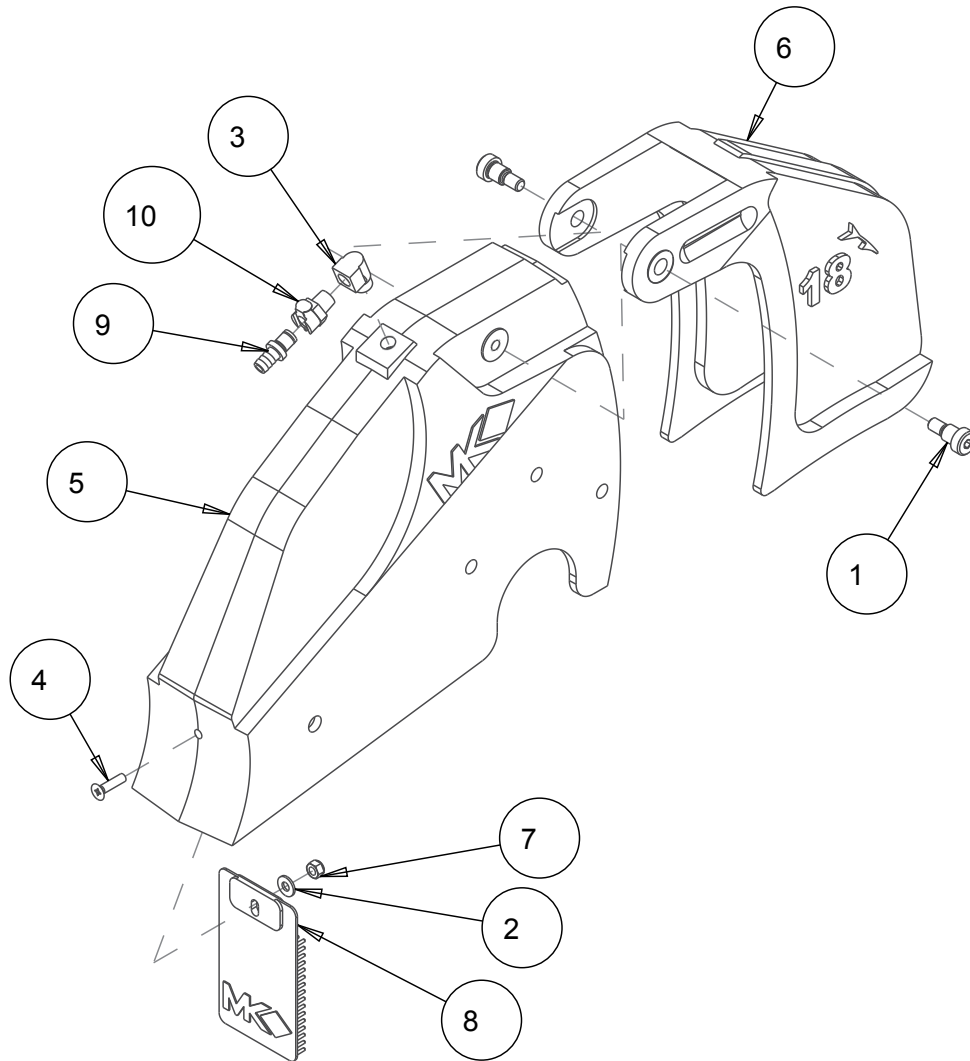

Item	Description	P/N	Qty
1	SCREW, SHOULDER, 1/2 X 1/2	151753	2
2	WASHER, FLAT, SAE, 1/4	151915	1
3	ELBOW, 1/4 MNPT STREET	154615	1
4	SCREW, FLAT HD, 1/4-20 X 1	157527	1
5	CASTING, BLD GRD, 18" REAR-COMP	159544	1
6	CASTING, BLD GRD, 18" FRONT-COMP	159645	1
7	NUT, HEX, NYLK, 1/4-20	159857	1
8	GUARD, SPLASH	160310	1
9	COUPLING, QD PLUG, 3/8 BARB	160464	1
10	COUPLING, QD SOCKET, 1/4MNPT	160465	1

FIGURE 11 ASSY, MTR, 5HP, 230V, 1PH P/N 172431

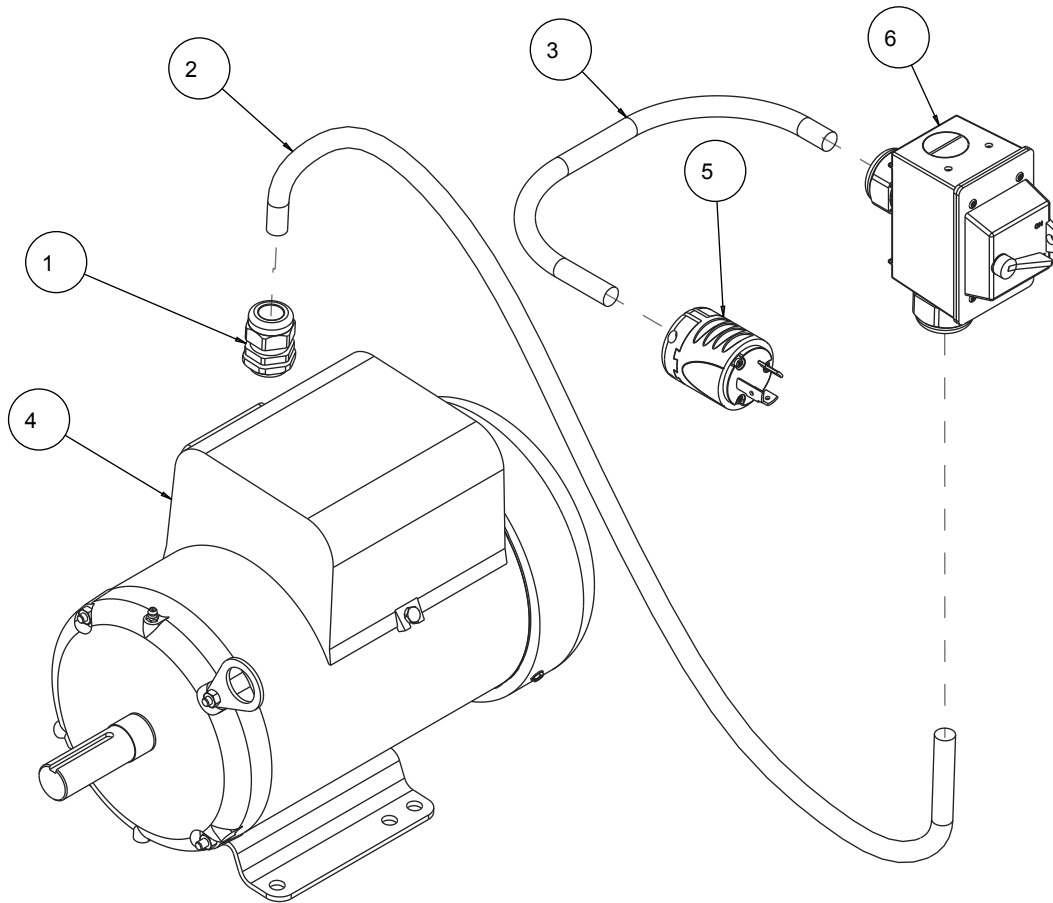

Item	Description	P/N	Qty
1	CONNECTOR, CORD, LTF21	160675	1
2	CORDAGE, ELEC, 10/3 SJOOW, BLACK, 45"	171227	1
3	CORD, ELEC, 10/3 SJOOW, BLACK, 18"	171227	1
4	MTR, 5HP, 230V, 1PH, 3450RPM-COMP	172414	1
5	PLUG, 240V, L6-30P	172437	1
6	ASSY, 30A SWITCH BOX, 2-MLTF1/2	172836-8	1