

LT100/LT112/LT120



1.1995

Spare parts

Ersatzteile

Pièces détachées

Reserve onderdelen

Repuestos

Reservdelar

Replaces

Ersetzt

Remplace

Vervangt

Reemplaza

Ersätter

106 23 08-64

A

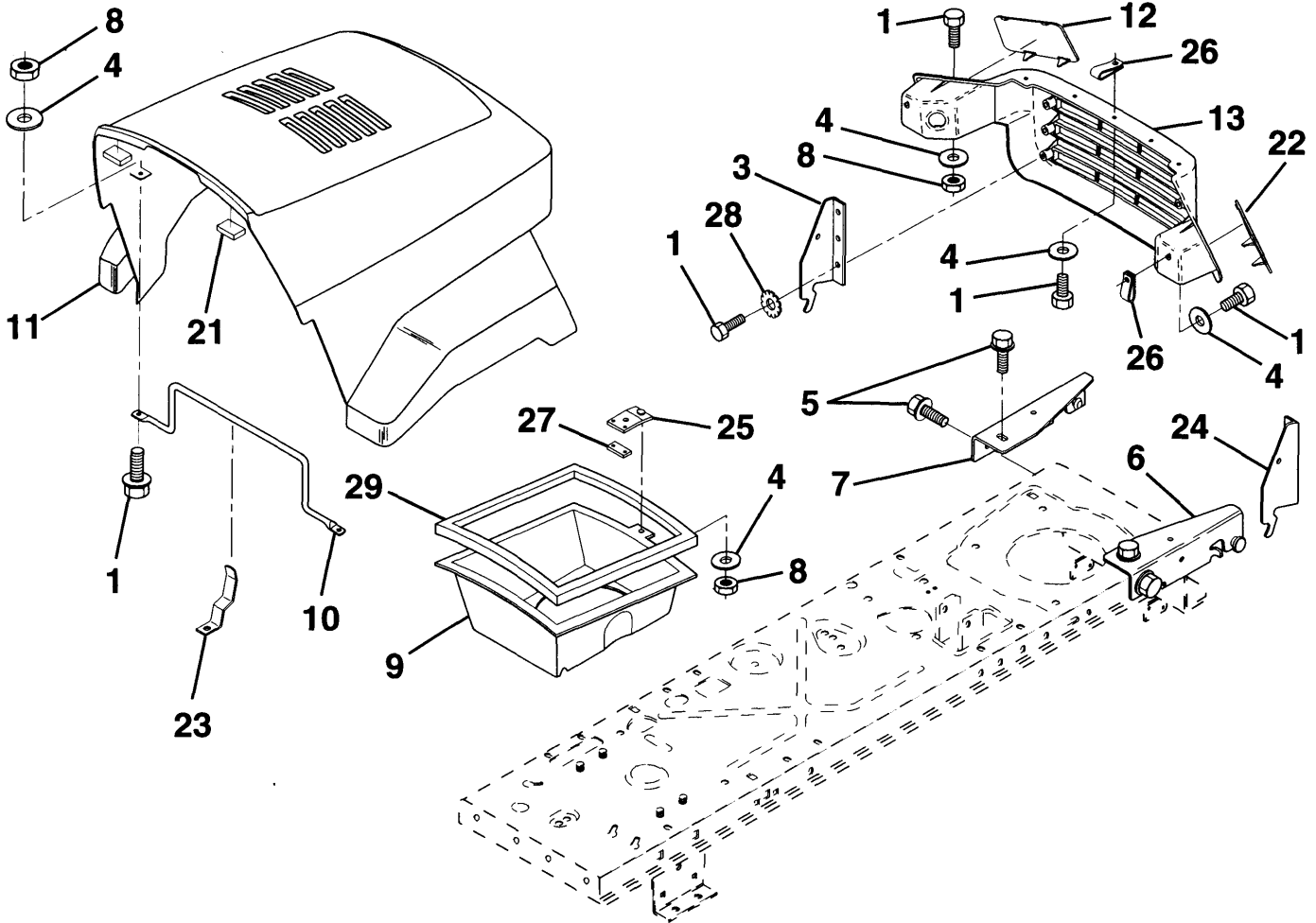

KEY NO.	PART NO.	DESCRIPTION
1	874 78 04-10	Bolt, Fin Hex 1/4-20 x 5/8
3	532 12 84-45	Bracket, Pivot Hood LH
4	819 09 10-16	Washer, Flat 1/4
5	817 49 05-12	Screw, Thdrol 5/16-18 x 3/4
6	532 14 00-51	Bracket, Asm. Pivot Frame RH
7	532 14 00-50	Bracket, Asm. Pivot Frame LH
8	873 68 04-00	Nut, Fin Hex 1/4-20
9	532 12 38-40	Duct, Air Hood
10	532 13 08-50	Brace, Hood
11	532 14 01-42	Hood
12	532 13 09-86	Lens, LH
13	532 13 09-84	Grille

KEY NO.	PART NO.	DESCRIPTION
21	532 12 69-38	Bumper, Hood
22	532 13 09-85	Lens RH
23	532 13 99-69	Latch, Hood
24	532 14 28-73	Bracket, Pivot Hood RH
25	532 13 10-37	Clip, Asm. Duct Air
26	532 05 29-21	Clip, Tinnerman
27	532 13 10-28	Clip, Tinnerman
28	811 05 04-00	Washer, Lock Ext. Tooth 1/4
29	532 12 05-37	Strip, Foam

NOTE: All component dimensions given in U.S. inches
1 inch = 25.4mm

HARDWARE SHOWN LARGER FOR EASIER IDENTIFICATION

B

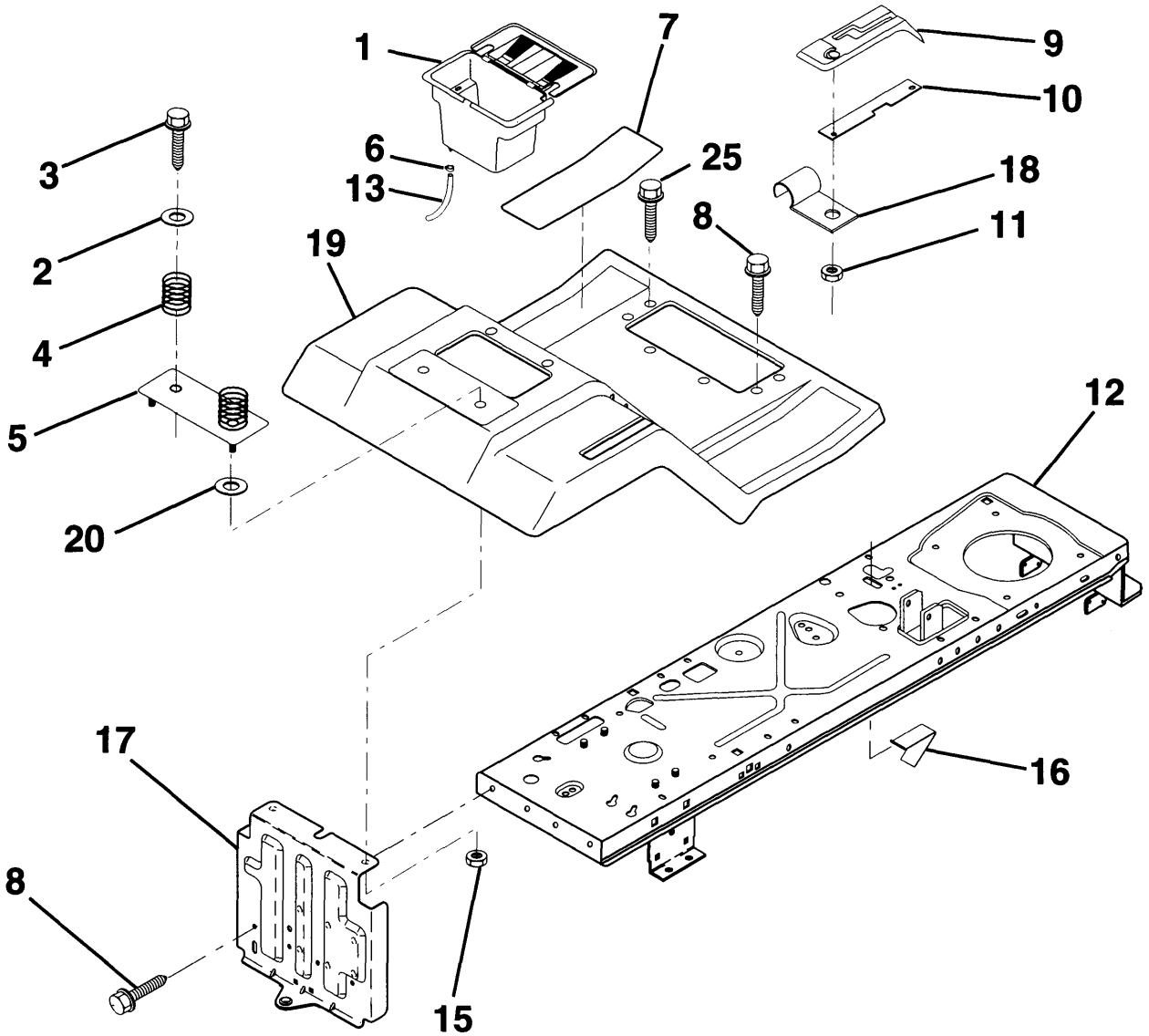

KEY PART NO.	NO.	DESCRIPTION
1	532 12 99-65	Case, Battery
2	819 13 20-12	Washer 13/32 x 1-1/4 x 12 Ga.
3	817 49 06-12	Screw, Hex Wsh. Thrdrol. 3/8-16 x 3/4
4	532 12 41-81	Spring, Compression, Seat
5	532 12 51-42	Plate, Asm. Battery
6	532 10 95-96	Clamp, Hose
7	532 12 67-00	Pad, Footrest
8	817 49 05-12	Screw, Hex Wsh. Thrdrol. 5/16-18 x 3/4

KEY PART NO.	NO.	DESCRIPTION
9	532 12 69-95	Console, Shift Control
10	532 13 97-83	Plate, Shift Lock
11	532 12 43-46	Nut, Self-Threading, Wsh Hd 3/16
12	532 14 51-90	Assembly, Frame
13	532 10 92-38	Tube, Battery Drain
15	873 68 05-00	Nut, Keps 1/4-20 UNC
16	532 14 17-36	Switch Actuator
17	532 14 07-82	Drawbar
18	532 12 64-70	Clip, Insulated
19	532 14 13-93	Fender/Footrest
20	819 09 14-13	Washer 9/32 x 7/8 x 13 Ga.
25	817 49 05-16	Screw Hex Wsh Thrdrol 5/16-18 x 1

NOTE: All component dimensions given in U.S. inches
1 inch = 25.4 mm

HARDWARE SHOWN LARGER FOR EASIER IDENTIFICATION

C

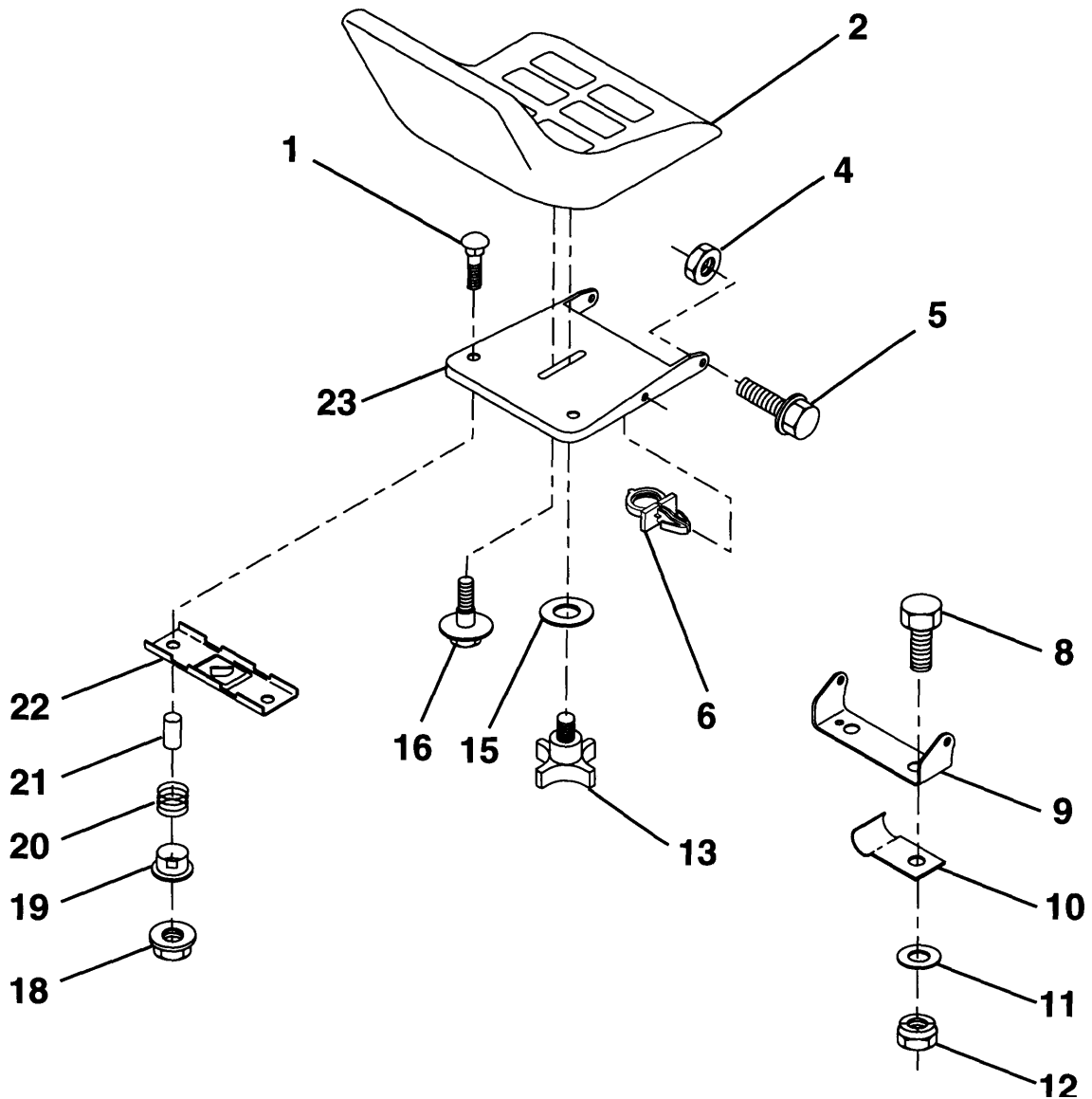

KEY NO.	PART NO.	DESCRIPTION
1	872 05 04-11	Bolt, Carriage 1/4-20 x 1 -3/8
2	532 12 73-98	Seat
4	873 80 05-00	Nut, Lock Hex w/Ins. 5/16-18
5	532 13 98-88	Bolt, Shoulder 5/16-18
6	532 14 50-06	Clip, Push-In
8	874 76 06-16	Bolt, Fin Hex 3/8-16 UNC x 1
9	532 14 05-51	Bracket, Pivot Seat
10	532 12 64-71	Clip, Insulator
11	819 13 32-10	Washer 12/32 x 2 x 10 Ga.
12	873 80 06-00	Nut, Lock Hex w/Wsh 3/8-16
13	532 12 00-68	Knob, Seat

KEY NO.	PART NO.	DESCRIPTION
15	819 17 19-12	Washer, 17/32 x 1 -3/16 x 12 Ga.
16	532 12 70-18	Bolt, Shoulder
18	532 12 39-76	Nut, Hex Large Flange Lock
19	532 12 12-48	Bushing, Snap
20	532 12 12-50	Spring, Compression
21	532 13 43-00	Spacer, Split 28 Id. x .96 Lg.
22	532 12 12-46	Bracket, Switch, Mounting
23	532 14 05-52	Pan, Seat

NOTE: All component dimensions given in U.S. inches
1 inch = 25.4 mm

HARDWARE SHOWN LARGER FOR EASIER IDENTIFICATION

D

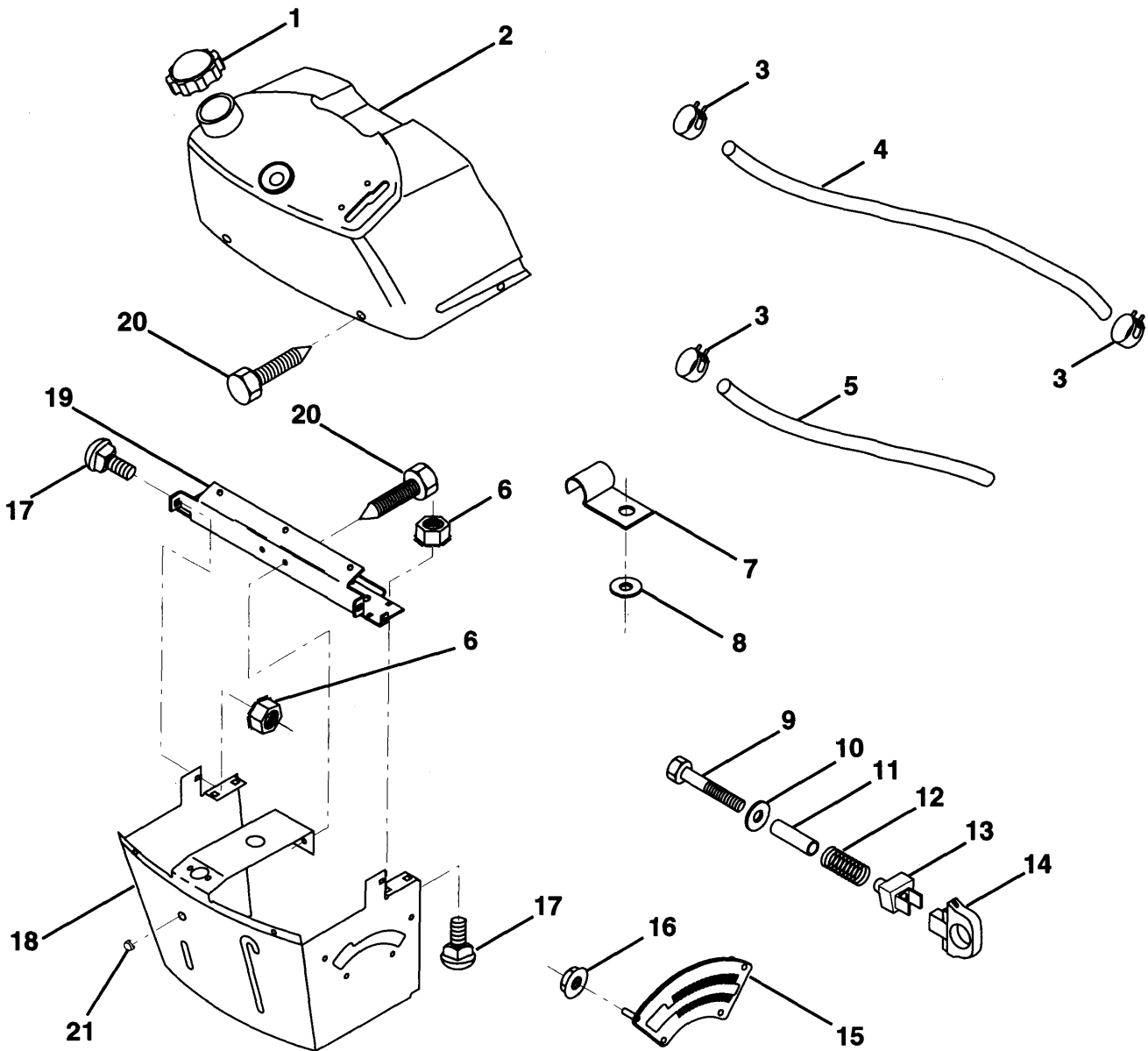

KEY NO.	PART NO.	DESCRIPTION
1	532 14 21-87	Cap, Fuel
2	532 13 83-95	Assembly, Dash & Fuel Tank
3	532 12 34-87	Clamp, Hose
4	532 00 85-44	Line, Fuel
5	532 00 85-48	Line, Fuel
6	873 51 04-00	Nut, Hex, Keps 1/4-20
7	532 12 49-96	Clip, Fuel Line
8	819 09 12-16	Washer 9/32 x 3/4 x 16 Ga.
9	874 76 04-28	Bolt, Hex, Fin 1/4-20 x 1-3/4
10	819 09 14-13	Washer 11/32 x 11/16 x 16 Ga.
11	532 12 12-49	Spacer, Split
12	532 00 37-20	Spring

KEY NO.	PART NO.	DESCRIPTION
13	532 12 64-50	Clip, Height Adjustment
14	532 12 61-15	Knob, Height Stop
15	532 12 20-23	Adjustment, Quadrant Height
16	532 12 43-46	Nut, Self-Threading 3/16-18
17	872 11 04-04	Bolt, Carriage 1/4-20 x 1/2 Gr. 5
18	532 13 07-45	Support Assembly, Dash
19	532 13 47-44	Brace, Cross
20	817 06 04-08	Screw, Self-Tapping 1 /4-20 x 1/2
21	532 13 40-14	Plug Dome Black

NOTE: All component dimensions given in U.S. inches
1 inch = 25.4mm

HARDWARE SHOWN LARGER FOR EASIER IDENTIFICATION

E

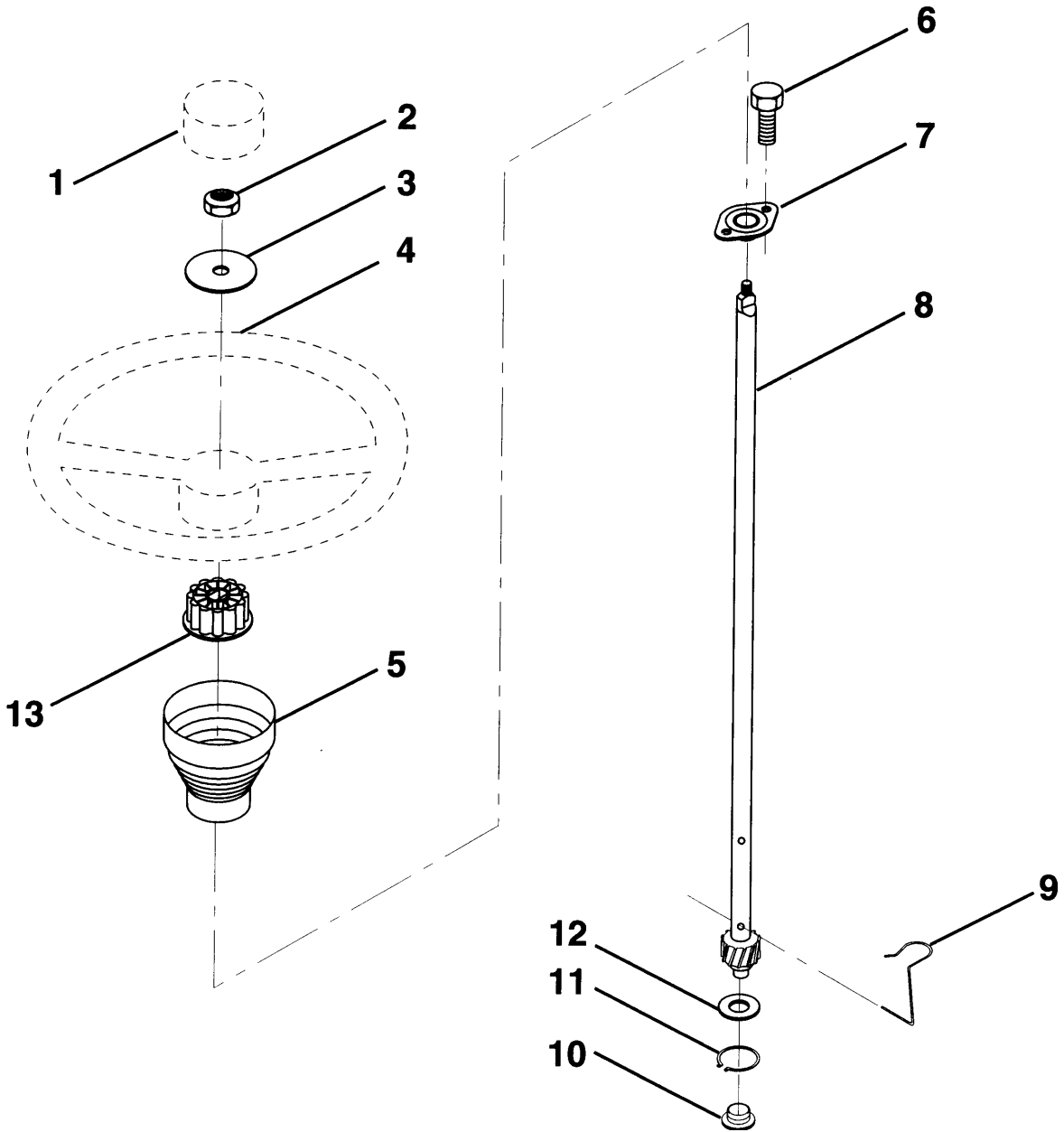

KEY NO.	PART NO.	DESCRIPTION
1	532 12 44-16	Insert, Wheel, Steering
2	532 12 47-01	Nut, Lock 3/8-24 UNF
3	819 13 38-08	Washer 12/32 x 2-3/8 x 8 Ga.
4	532 12 44-15	Wheel, Steering
5	532 12 73-96	Sleeve, Steering
6	817 43 10-08	Screw, Hex #10-16 x 1/2 TY-B
7	532 10 28-03	Bushing, Steering
8	532 12 36-51	Shaft, Steering

KEY NO.	PART NO.	DESCRIPTION
9	532 12 42-10	Clip, Steering
10	532 12 34-38	Bushing, Lower, Steering
11	812 00 00-45	Ring, Retaining
12	819 21 16-16	Washer 21/32x1 x 16Ga.
13	532 10 48-20	Adaptor, Wheel, Steering

NOTE: All component dimensions given in U.S. inches
1 inch = 25.4 mm

HARDWARE SHOWN LARGER FOR EASIER IDENTIFICATION

F

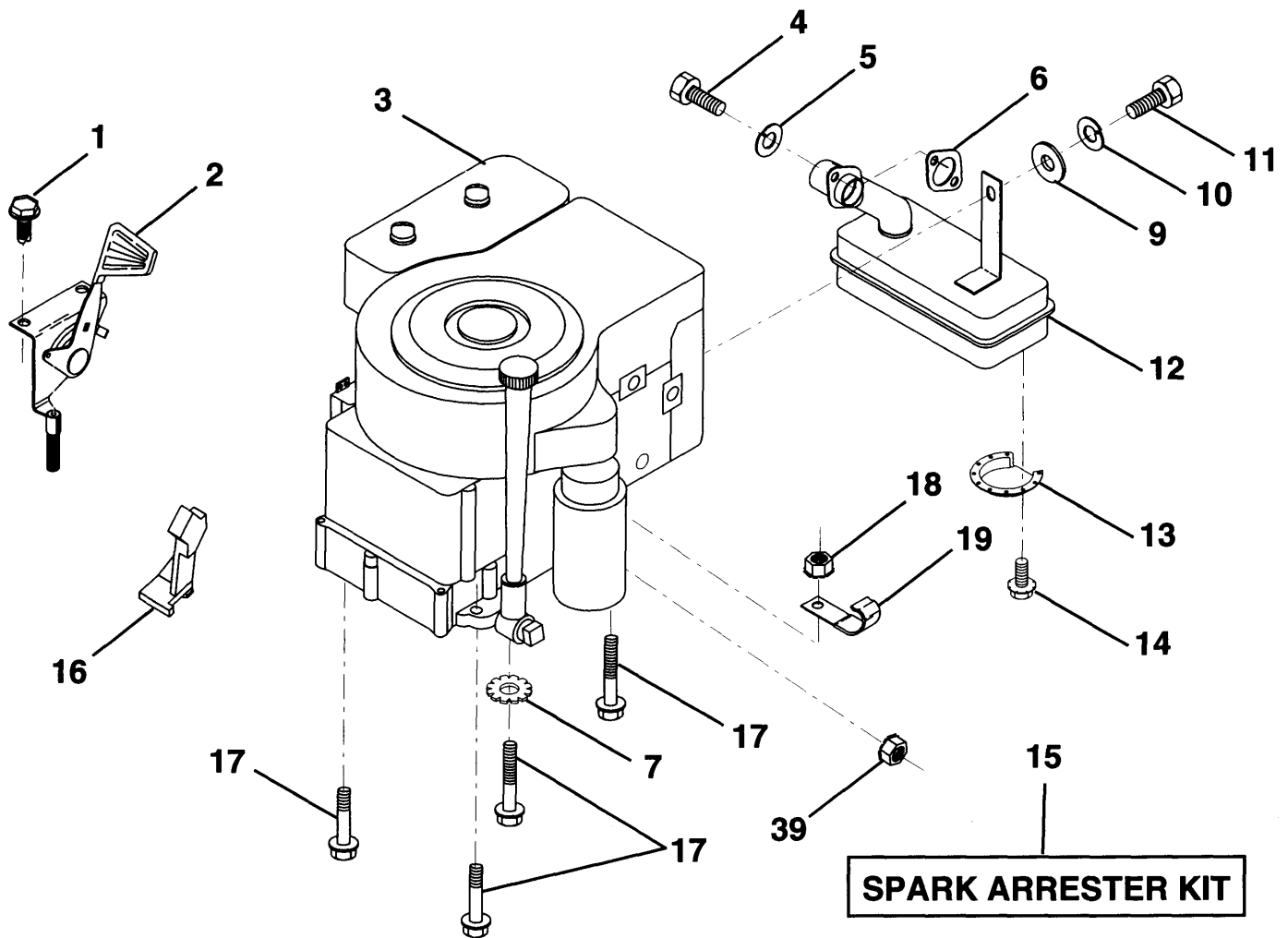

SPARK ARRESTER KIT

KEY NO.	PART NO.	DESCRIPTION
1	817 06 04-08	Screw, Hex Thd. Cut 1/4-20 x 1/2
2	532 13 30-25	Control, Throttle
3	-----	Engine, Briggs & Stratton
4	871 07 05-12	Screw, Hex, Cap 5/16-18 x 3/4
5	810 04 05-00	Washer, Lock Heavy Helical Spring 5/16
6	532 12 55-93	Gasket, Exhaust
7	811 05 06-00	Washer, Lock Ext. Tooth 3/8
9	819 10 12-16	Washer 5/16 x 3/4 x 16
10	810 04 04-00	Washer, Lock Heavy Helical Spring 1/4
11	874 76 04-12	Bolt, Hex Fin. 1/4-20 UNC x 3/4

KEY NO.	PART NO.	DESCRIPTION
12	532 13 74-37	Muffler
13	532 10 13-26	Deflector, Muffler
14	817 03 08-08	Screw, Spiderloc
15	532 13 71-80	Arrester, Spark (Optional equipment)
16	532 12 79-51	Stop, Throttle
17	817 49 06-24	Screw, Hex Washer Head, Thdrol. 3/8-16 x 1-1/2
18	873 22 06-00	Nut, Keps Hex 3/8-16
19	532 12 49-96	Clip, Line Fuel
39	873 51 04-00	Nut Keps Hex 1/4-20

NOTE: All component dimensions given in U.S. inches
1 inch = 25.4 mm

HARDWARE SHOWN LARGER FOR EASIER IDENTIFICATION

G

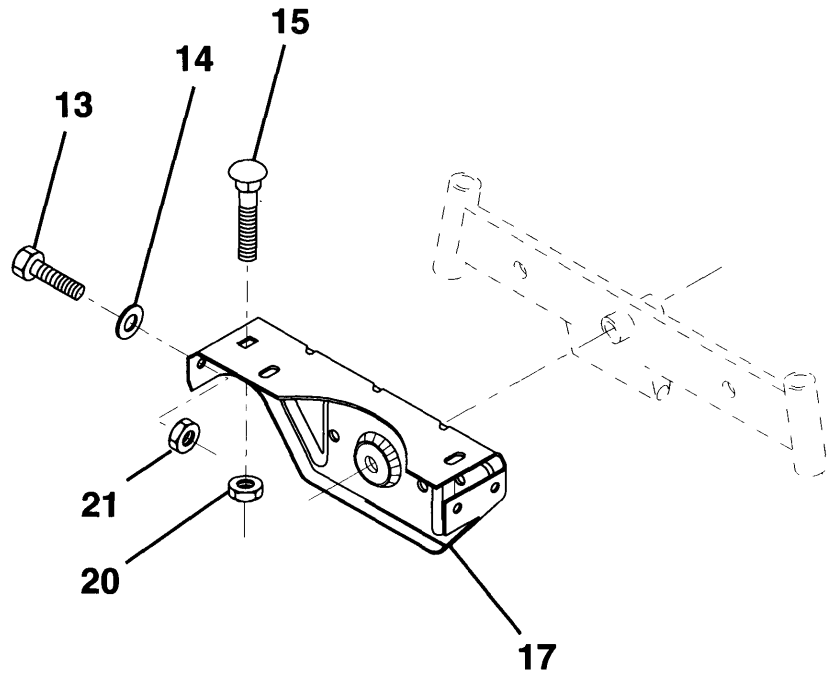
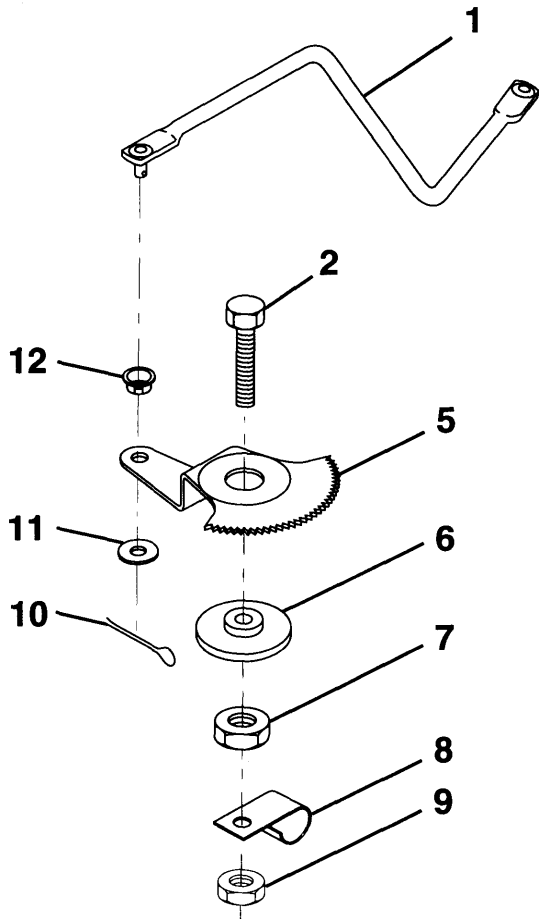

KEY NO.	PART NO.	DESCRIPTION
1	532 13 25-66	Link, Drag
2	874 78 08-28	Bolt, Fin Hex 1/2-13 x 1-3/4
5	532 12 19-26	Gear Sector
6	532 12 19-27	Bushing
7	873 03 08-00	Nut, Heavy Hex Top Lock 1/2-13UNC
8	532 12 64-72	Clip, Insulated
9	873 68 08-00	Nut, Crownlock 3/8-16
10	876 02 04-12	Pin, Cotter 1/8 x 3/4
11	819 13 13-16	Washer, 13/32 x 13/16 x 16 Ga.

KEY NO.	PART NO.	DESCRIPTION
12	532 12 68-47	Bushing
13	874 76 05-12	Bolt, Hex Hd. 5/16-18 UNC x 3/4
14	819 11 14-16	Washer 11/32x7/8 x16 Ga.
15	872 11 06-06	Bolt, Carriage 3/8-16 UNC x 3/4
17	532 13 70-96	Support, Front Axle
20	873 68 06-00	Nut, Crownlock 3/8-16
21	873 68 05-00	Nut, Crownlock 5/16-18

NOTE: All component dimensions given in U.S. inches
1 inch = 25.4 mm

HARDWARE SHOWN LARGER FOR EASIER IDENTIFICATION

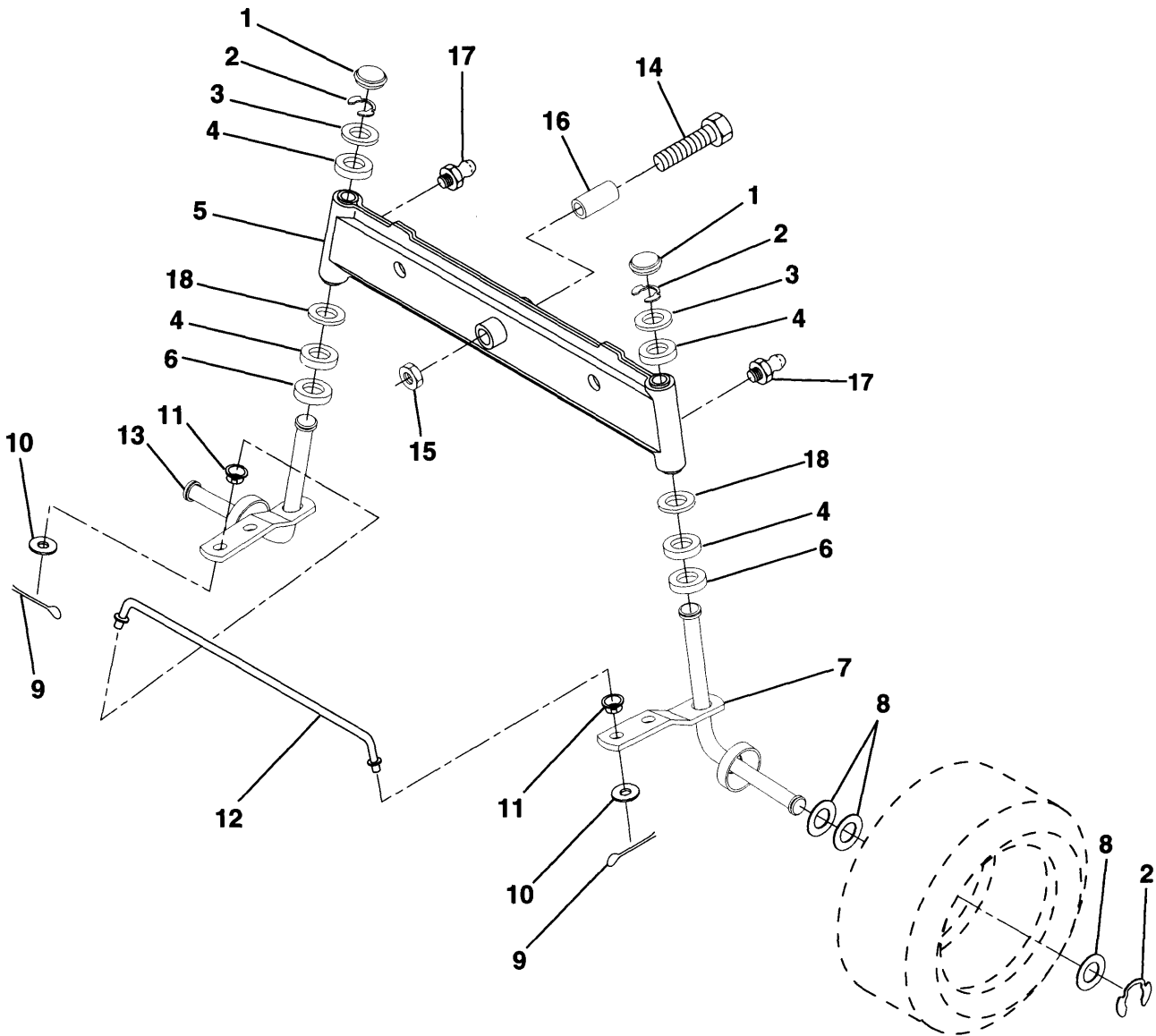

KEY NO	PART NO.	DESCRIPTION
1	532 12 12-32	Cap, Spindle
2	812 00 00-29	Ring, Clip
3	532 12 17-48	Washer 25/32 x1-5/8x16 Ga.
4	532 12 49-37	Bearing, Col Strg.
5	532 14 20-33	Axle, Front
6	532 12 49-31	Bearing Thrust
7	532 13 70-62	Spindle R.H. Asm.
8	532 12 17-49	Washer 25/32 x 1-1/4 x 16 Ga.
9	876 02 04-12	Pin,Cotter 1/8 x 3/4
10	819 13 13-16	Washer 13/32 x 13/16 x 16 Ga.

KEY NO	PART NO.	DESCRIPTION
11	532 12 68-47	Bushing
12	532 13 04-65	Rod, Tie
13	532 13 70-61	Spindle,L.H.Asm.
14	874 01 10-56	Bolt, Hex 5/8-11 x3-1/2
15	873 90 10-00	Locknut, Flange 5/8-11
16	532 11 04-38	Spacer, Bearing
17	532 12 48-36	Fitting, Grease
18	819 27 20-16	Washer 27/32 x 1-1/4 x 16 Ga.

NOTE: All component dimensions given in U.S. inches
1 inch = 25.4 mm

HARDWARE SHOWN LARGER FOR EASIER IDENTIFICATION

J

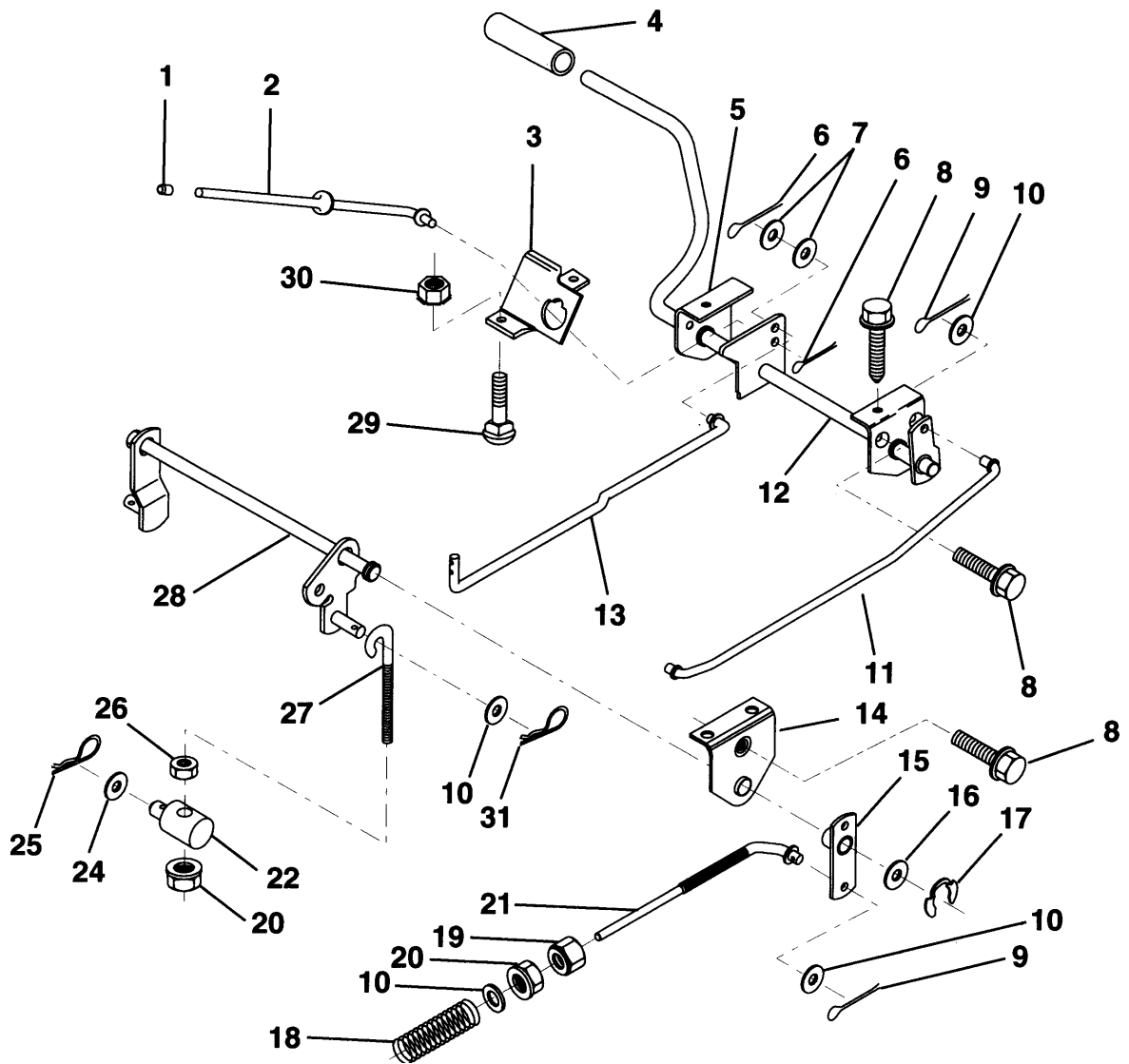

KEY NO	PART NO.	DESCRIPTION
1	532 07 16-73	Cap, Plunger
2	532 12 34-36	Rod, Parking Brake
3	532 12 34-37	Bracket, Parking Brake
4	532 00 81-56	Cover, Pedal
5	532 12 25-04	Bracket, Clutch/Brake Pedal, L.H.
6	876 02 03-12	Pin, Cotter 3132x314
7	819 13 10-16	Washer 13/32 x 5/8 x 16 Ga.
8	817 49 05-08	Screw, Hex, Thd. Roll. 5/16-18 x 1/2
9	876 02 04-12	Pin, Cotter 118 x 314
10	819 13 13-16	Washer 13/32 x 13/16 x 16 Ga.
11	532 12 35-43	Rod, Brake Front
12	532 13 99-33	Assembly, Clutch/Brake Pedal
13	532 12 33-94	Rod, Clutch
14	532 12 19-78	Bracket, Lift, Shaft
15	532 13 33-32	Assembly, Brake, Pivot, Arm
16	819 25 18-16	Washer 25/32 x 1-1/8 x 16 Ga.

KEY NO	PART NO.	DESCRIPTION
17	812 00 00-34	Ring, Klip
18	532 10 68-88	Spring, Brake Rod
19	873 35 06-00	Nut, Hex, Jam 3/8-16 UNC
20	873 68 06-00	Nut, Crownlock 3/8-16
21	532 13 14-60	Rod, Rear Brake
22	532 14 45-85	Trunnion, Lift
24	819 13 20-12	Washer 13/32 x 1-1/4 x 12 Ga.
25	532 12 49-61	Spring, Retainer
26	873 93 06-00	Nut, Centerlock 3/8-16 UNC
27	532 12 73-69	Link, Threaded
28	532 14 07-76	Assembly, Rear Mower Lift
29	872 11 05-06	Bolt, Carriage 5/16-18 UNCx3/4
30	873 51 05-00	Nut, Keps 5/16-16 UNC
31	532 12 46-60	Retainer, Spring

NOTE: All component dimensions given in U.S. inches
1 inch = 25.4 mm

K

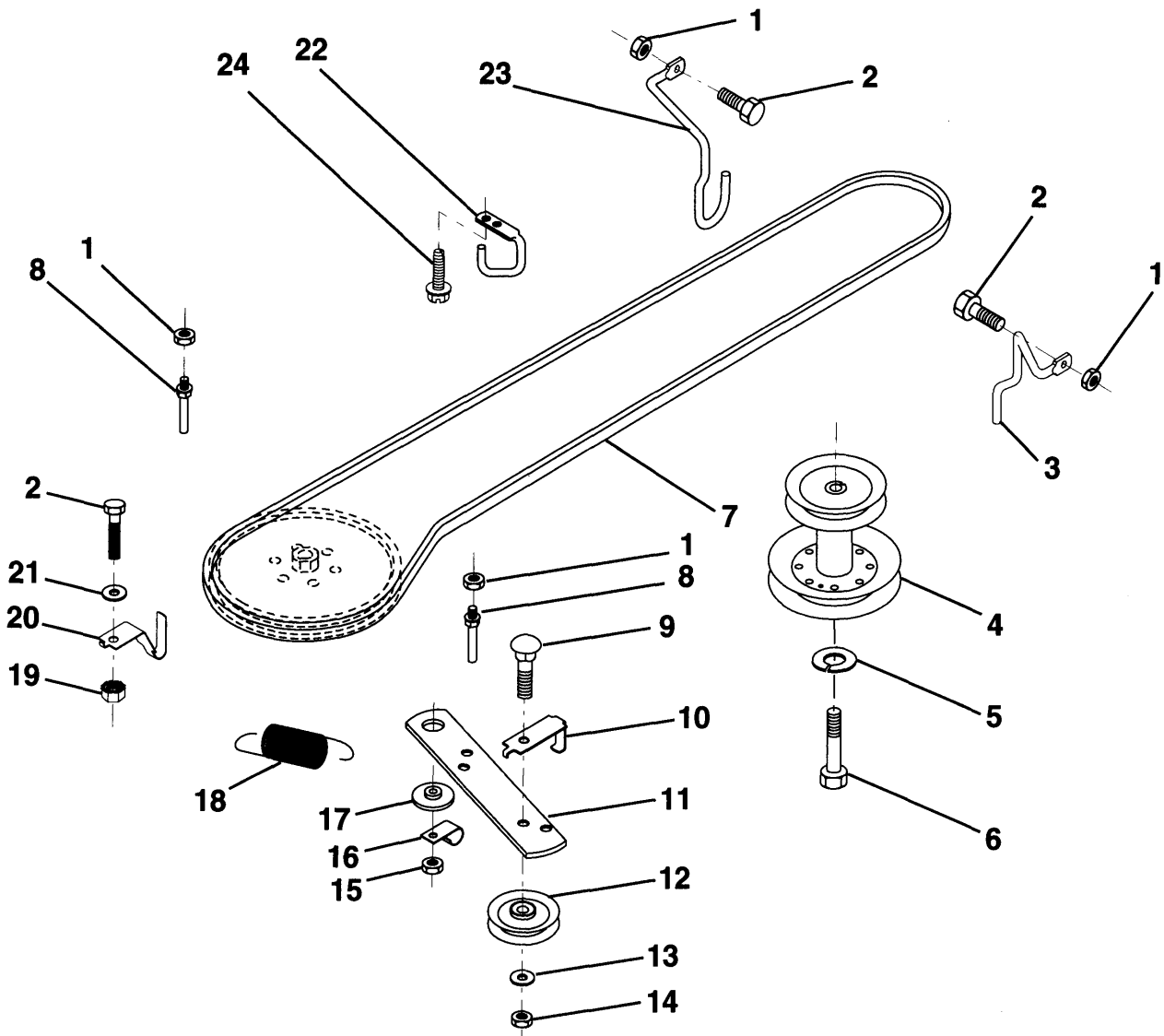

KEY NO.	PART NO.	DESCRIPTION
1	873 68 05-00	Nut Crownlock 5/16-18
2	874 76 05-12	Bolt, Hex Hd 5/16-18 UNC x 3/4
3	532 14 13-42	Keeper, Mower Drive, R. H.
4	532 13 80-29	Pulley, Engine
5	810 04 07-00	Washer, Lock 7/16
6	871 17 07-44	Bolt Hex 7/16-20 Gr. 5
7	532 12 65-20	Traction V-Belt, Drive
8	532 12 34-05	Keeper, T/A Ground Drive Belt
9	872 14 06-12	Bolt, Carr. 3/8-16 UNC x 1-1/2
10	532 12 33-96	Keeper, Belt Ground Drive idler
11	532 14 09-11	Arm, Ground Drive Clutch
12	532 12 36-74	Idler, Flat
13	819 13 13-16	Washer 13/32 x 13/16 x 16 Ga.

KEY NO.	PART NO.	DESCRIPTION
14	873 93 06-00	Nut, Centerlock 3/8-16Unc
15	873 68 06-00	Nut, Crownlock 3/8-16
16	532 12 64-71	Clip, Insulated
17	532 12 20-52	Spacer, Retainer
18	532 13 14-59	Spring Extension
19	873 51 05-00	Nut, Keps 5/16-18 UNC
20	532 13 99-19	Keeper, T/A Ground Drive Belt
21	819 11 10-16	Washer 11/32 x 5/8 x 16 Ga.
22	532 12 34-04	Keeper, Frame Ground Drive Belt
23	532 14 09-16	Keeper, Mower Drive, L. H.
24	817 72 04-08	Screw, Thd Cut 1/4-20 x 1/2

NOTE: All component dimensions given in U.S. inches
1 inch = 25.4 mm

HARDWARE SHOWN LARGER FOR EASIER IDENTIFICATION

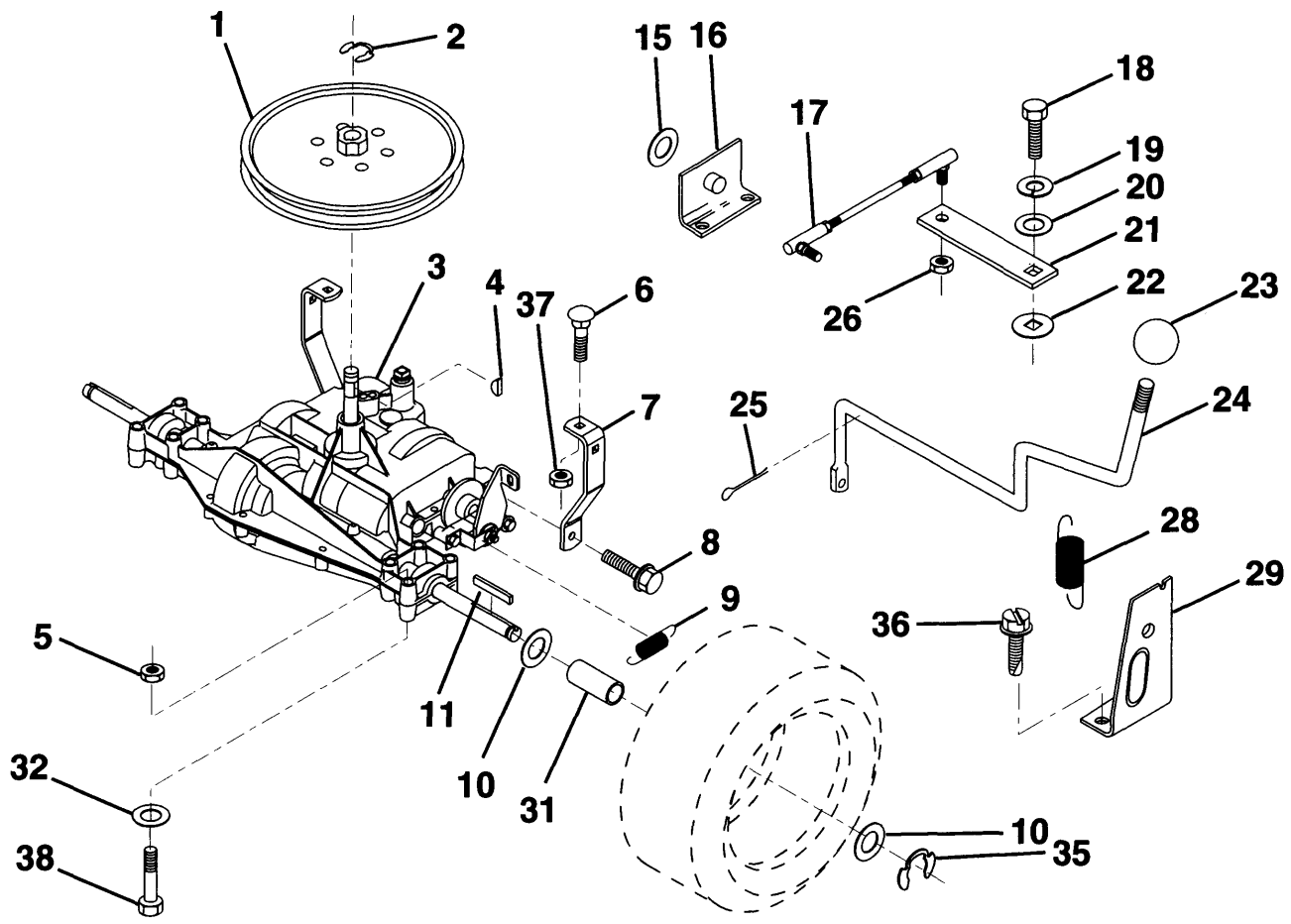

KEY NO.	PART NO.	DESCRIPTION
1	532 12 33-85	Pulley
2	812 00 00-28	Ring, Retainer
3	-----	Transaxle, Peerless
4	532 12 50-96	Key, Woodruff #9
5	873 80 05-00	Nut, Lock Hex w/Ins. 5/16-18
6	872 14 05-06	Bolt, Carriage 5/16-18 UNC x 3/4
7	532 12 33-78	Strap, Torque
8	817 49 05-12	Screw 5/16-18 x 3/4
9	532 11 04-22	Spring, Brake
10	532 12 17-49	Washer 25/32 x 1-1/4 x 16 Ga.
11	532 12 35-83	Key, Square
12	874 76 05-40	Bolt, Fin Hex 5/16-18 x 2-1/2
15	819 17 16-16	Washer 17/32 x 1 x 16 Ga.
16	532 12 46-00	Support, Handle Shift LH
17	532 12 62-93	Link, Shift
18	871 04 04-12	Bolt, Fin Hex 1/4-28 UNF x 3/4 Gr. 8
19	810 04 04-00	Washer, Lock 1/4

KEY NO.	PART NO.	DESCRIPTION
20	819 09 12-10	Washer 9/32 x 3/4 x 10 Ga.
21	532 12 62-92	Arm, Shift
22	532 10 57-01	Washer, Shift Plate
23	532 12 12-74	Knob, Duckhead
24	532 12 82-15	Rod, Shift
25	876 02 04-16	Pin, Cotter 1/8 x 1
26	873 81 05-00	Locknut 5/16-24 UNF
28	532 12 80-85	Spring, Extension
29	532 12 80-84	Support, Handle Shift RH
31	532 13 70-57	Spacer, Axle
32	819 11 11-16	Washer 11/32 x 11/16 x 16 Ga.
35	812 00 00-01	E-Ring
36	874 78 04-08	Screw, Thdcut 1/4-20 x 1/2
37	873 68 05-00	Nut, Crownlock 5/16-18

NOTE: All component dimensions given in U.S. inches
1 inch = 25.4 mm

HARDWARE SHOWN LARGER FOR EASIER IDENTIFICATION

M

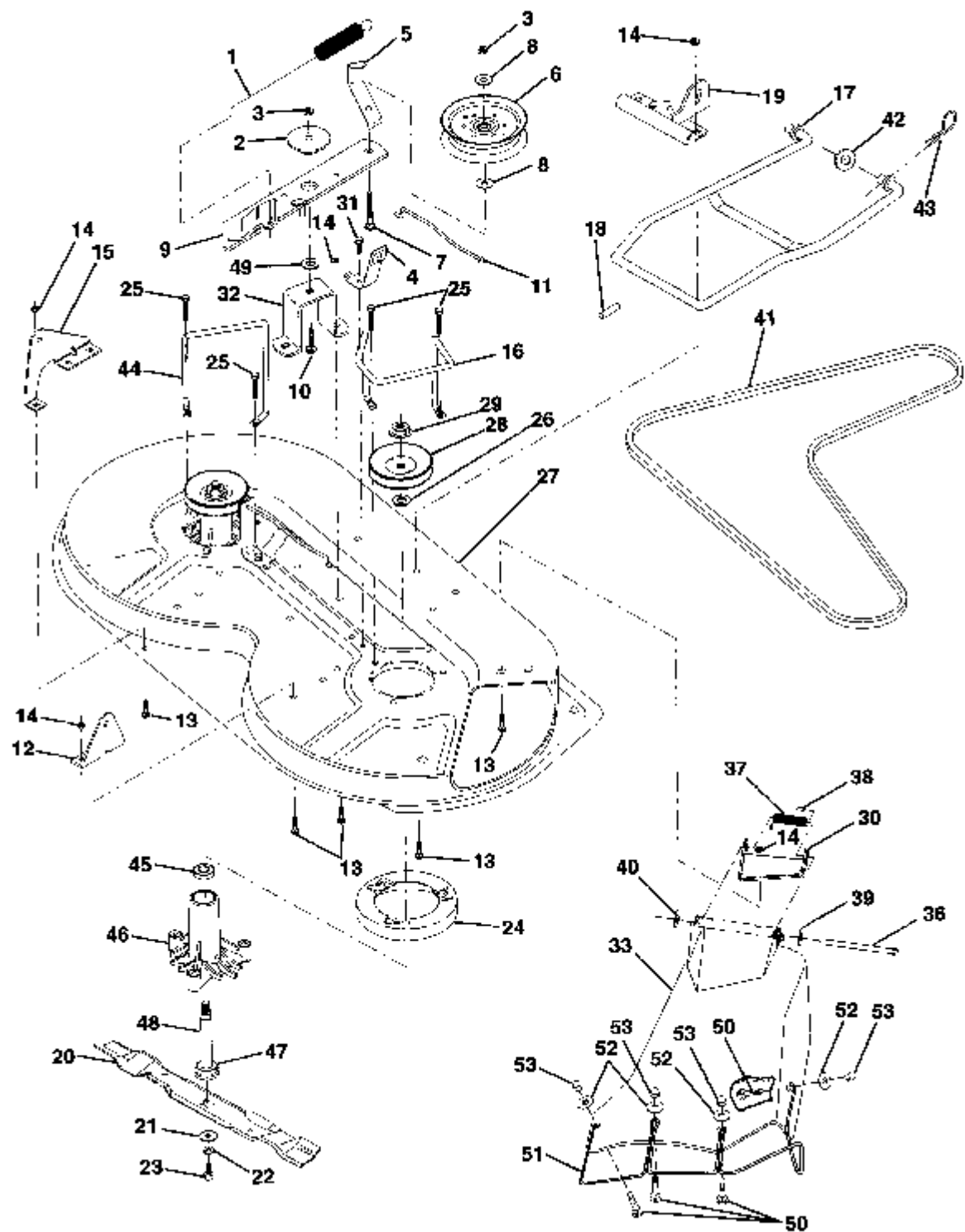

KEY NO.	PART NO.	DESCRIPTION
1	532 14 00-64	Spring, Mower Clutch
2	532 12 20-52	Spacer, Retainer
3	873 68 06-00	Nut, Crownlock 3/8 - 16
4	532 13 08-40	Brake Asm.
5	532 13 12-51	Guide, Belt idler
6	532 12 13-16	Pulley, idler Flat
7	872 11 06-16	Bolt, Carr. 3/8-16 x 1 -3/4 Gr. 5
8	819 13 14-10	Washer 13/21 x 7/8 x 10 Ga.
9	532 12 77-44	Arm Asm., Idler Mower
10	872 14 06-10	Bolt, Carriage 3/8-16 x 1 -1 /4
11	532 13 08-41	Rod, Brake
12	532 12 73-56	Bracket, Lift R. H. Rear
13	872 14 05-06	Bolt, Carriage 5/16-18 x 3/4
14	873 68 05-00	Nut, Crownlock 5/16-18
15	532 12 73-57	Bracket, Lift L. H. Rear
16	532 14 00-93	Keeper, R. H.
17	532 12 85-08	Link, Asm. Mower Stabilizer
18	532 12 85-11	Pin, Drive
19	532 12 73-80	Bracket, Asm. Front
20	532 13 84-96	Blade, High Lift
21	532 14 02-96	Washer, Hardened
22	810 03 06-00	Washer, Lock 3/8
23	532 85 08-57	Bolt 3/8-24 x 1-1/4Gr.8
24	532 14 03-29	Stripper
25	532 13 87-76	Bolt 5/16-18 x 1 -1 /4
26	532 12 99-63	Washer .150 Thk.
27	532 12 99-83	Deck Assembly
28	532 12 92-07	Pulley, Mandrel
29	532 13 72-66	Nut, Flangelock 9/16
30	532 13 66-31	Bracket, Asm. Deflector

KEY NO.	PART NO.	DESCRIPTION
31	817 49 05-08	Screw, Hex Wsh. Thdrol. 5/16-18 x 1/2
32	532 12 20-51	Arm, Support idler Mower
33	532 13 15-60	Deflector
36	532 12 19-80	Rod, Hinge
37	532 12 37-13	Spring, Torsion Deflector
38	532 10 53-04	Cap, Sleeve
39	819 11 10-16	Washer 11/32 x 5/8 x 16 Ga.
40	532 11 04-52	Pushnut
41	532 13 12-64	V-Belt
42	819 17 16-16	Washer 11/32 x 5/8 16 Ga.
43	532 12 46-60	Retainer, Spring
44	532 14 06-08	Keeper, L.H.
45	532 11 04-85	Bearing
46	532 12 87-74	Housing, Mandrel Vented
47	532 12 98-95	Bearing
48	532 13 76-45	Shaft, Mandrel (Includes Key No. 47)
--	532 13 07-94	Mandrel Asm. (Includes Key Nos. 22-23, 26, 29 and 45-48)
49	532 13 39-43	Washer, Hardened
50	532 14 59-89	Bolt, Rd.Hd.Sq.Nk.M5xO.8 x 16 mm
51	532 13 63-83	Guard, Deflector Mower 36" TUV(w.Form)
52	734 11 46-01	Washer 7/32 x 7/16 x 18 Ga.
53	532 14 59-90	Nut, Acorn M5 x 0.8

NOTE: All component dimensions given in U.S. inches
1 inch = 25.4 mm

HARDWARE SHOWN LARGER FOR EASIER IDENTIFICATION

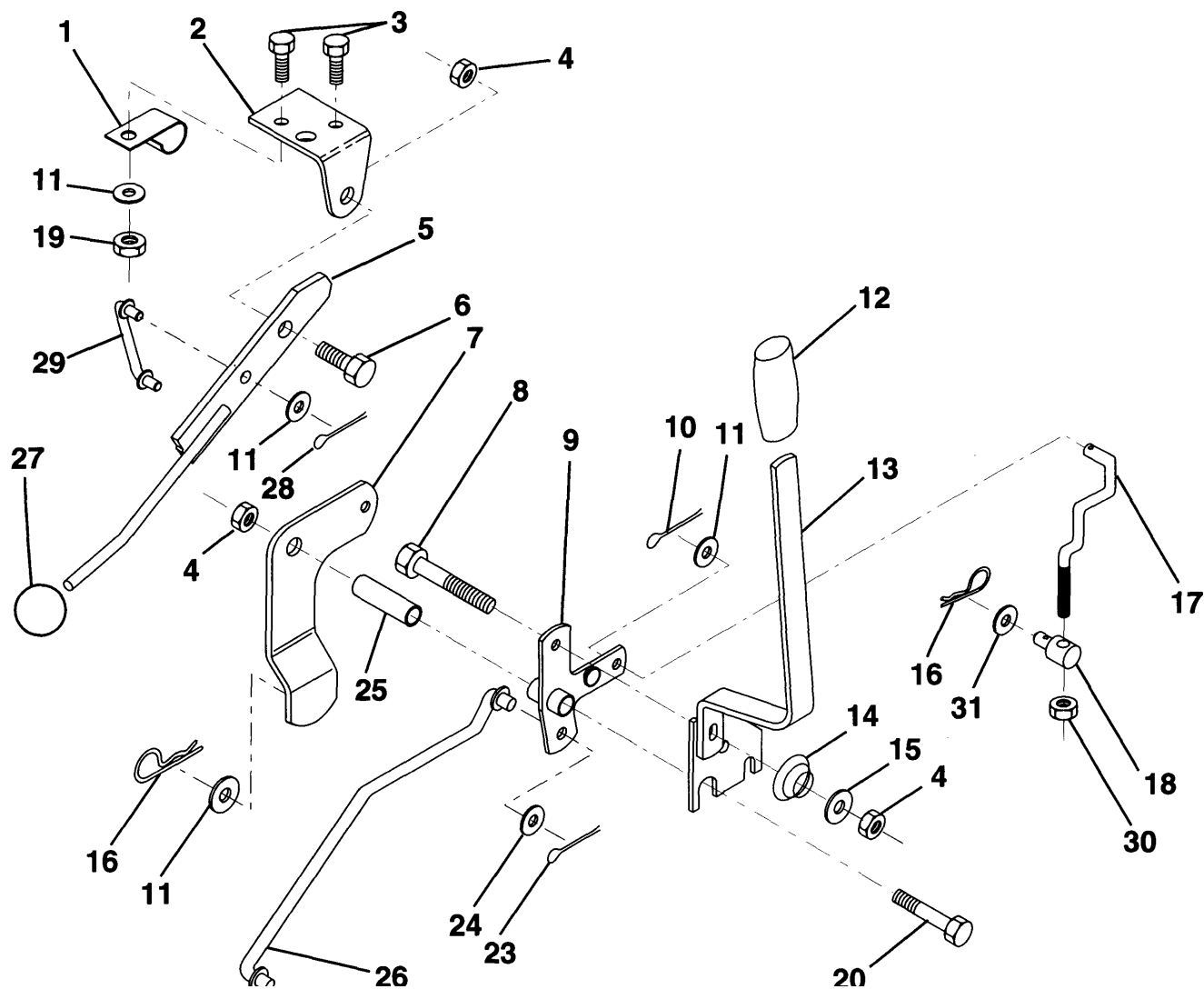
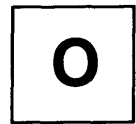

KEY NO.	PART NO.	DESCRIPTION
1	532 12 64-70	Clip, Insulated
2	532 12 20-18	Bracket, Mower Clutch
3	874 78 04-08	Bolt, Fin. Hex 1/4-20 UNC x 1/2
4	873 68 06-00	Nut, Crownlock 3/8-16 UNC
5	532 14 51-87	Assembly, Clutch Lever
6	532 10 64-51	Bolt, Shoulder
7	532 13 53-71	Assembly, Mower Clutch Arm
8	874 76 06-36	Bolt, Hex 3/8-16 UNC x 2-1/4
9	532 12 19-30	Assembly, Bellcrank Lift
10	876 02 04-12	Pin, Cotter 1/8 x 3/4
11	819 13 13-16	Washer 13/32 x 13/16 x 16 Ga.
12	532 12 20-27	Grip, Handle LT 120
12	532 13 18-61	Grip, Handle LT 100/112
13	532 13 93-52	Assembly, Lift Handle
14	532 12 34-96	Spring, Compression
15	819 13 12-12	Washer 13/32 x 3/4 x 12 Ga.

KEY NO.	PART NO.	DESCRIPTION
16	532 12 49-61	Retainer, Spring
17	532 12 73-59	Link, Front Lift
18	532 14 20-28	Trunnion, Threaded 3/8-16
19	873 68 04-00	Nut, Crownlock 1/4-20
20	874 76 06-44	Bolt, Fin. Hex 3/8-16 UNC x 2-3/4
23	876 02 04-16	Pin, Cotter 1/8x1
24	819 17 16-12	Washer 17/32x1x12Ga.
25	532 12 19-33	Tube, Spacer
26	532 14 14-70	Rod, Mower Lift
27	532 12 14-66	Knob LT 120
27	532 10 69-32	Knob LT 100/112
28	876 02 03-12	Pin, Cotter 3132 x 314
29	532 13 16-55	Link, Mower Clutch
30	873 35 06-00	Nut, Hex Jam 3/8-16
31	819 13 20-12	Washer 13/32 x 1 -1/4 x 12 Ga.

NOTE: All component dimensions given in U.S. inches
1 inch = 25.4 mm

HARDWARE SHOWN LARGER FOR EASIER IDENTIFICATION

P

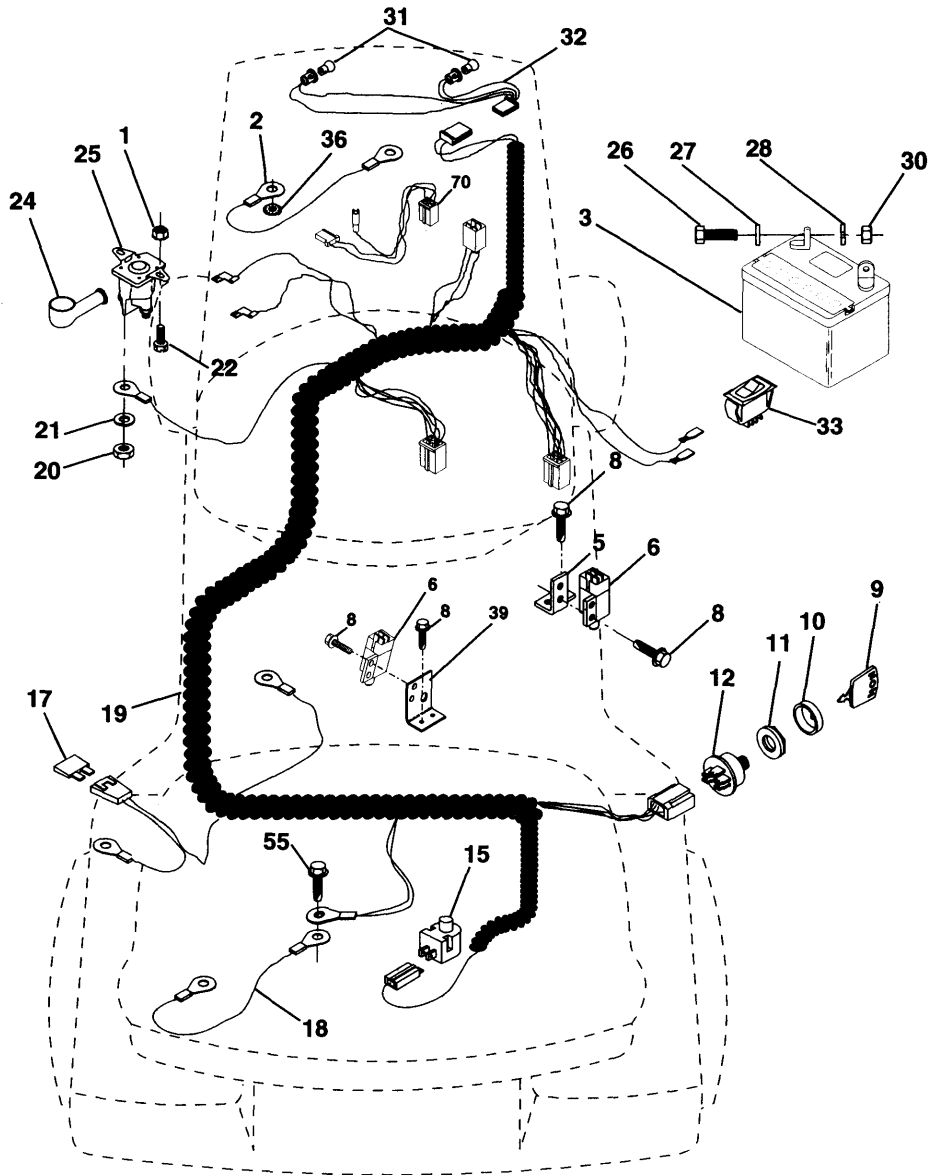

KEY NO.	PART NO.	DESCRIPTION	KEY NO.	PART NO.	DESCRIPTION
1	873 64 04-00	Nut, Hex Keps 1/4-20	22	874 780408	Bolt, Fin. Hex 1/4-20 UNC x 1/2 Gr. 5
2	532 10 84-23	Assembly, Cable	24	532 13 15-63	Cover, Terminal
3	532 14 49-24	Battery	25	532 14 56-73	Solenoid
5	532 10 82-36	Bracket, Switch	26	874 76 04-12	Bolt, Hex Hd. 1/4-20 UNC x 3/4
6	532 10 95-53	Switch, Interlock (4-terminal)	27	819 09 10-16	Washer 9/32 x 5/8 x 16
8	817 02 10-08	Screw, Hex Hd. Tap #10-24 x 1/2	28	810 04 04-00	Washer, Lock 1/4
9	532 14 04-01	Key, Molded	30	873 22 04-00	Nut, Fin. Hex 1/4-20 UNC
10	532 14 12-26	Cover, Key Ignition	31	532 00 41-52	Bulb, Light
11	532 14 04-00	Nut, Ignition	32	532 14 28-81	Harness, Headlight
12	532 14 49-21	Switch, Ignition	33	532 11 07-12	Switch, Light
15	532 12 13-05	Switch, Plunger	36	810 04 04-00	Washer, Lock Inter. Tooth 1/4
17	532 10 88-24	Fuse	39	532 14 17-35	Bracket, Switch Clutch
18	532 12 83-53	Assembly, Cable	55	817 49 05-08	Screw, Thdrol 5/16 - 18 x 1/2
19	532 14 60-64	Harness, Ignition LT 120	70	532 14 04-13	Harness, Engine
19	532 14 60-63	Harness, Ignition LT 100/112			
20	873 35 04-00	Nut, Hex Jam 1/4-20			
21	810 09 04-00	Washer, Lock 1/4			

NOTE: All component dimensions given in U.S. inches
1 inch = 25.4 mm

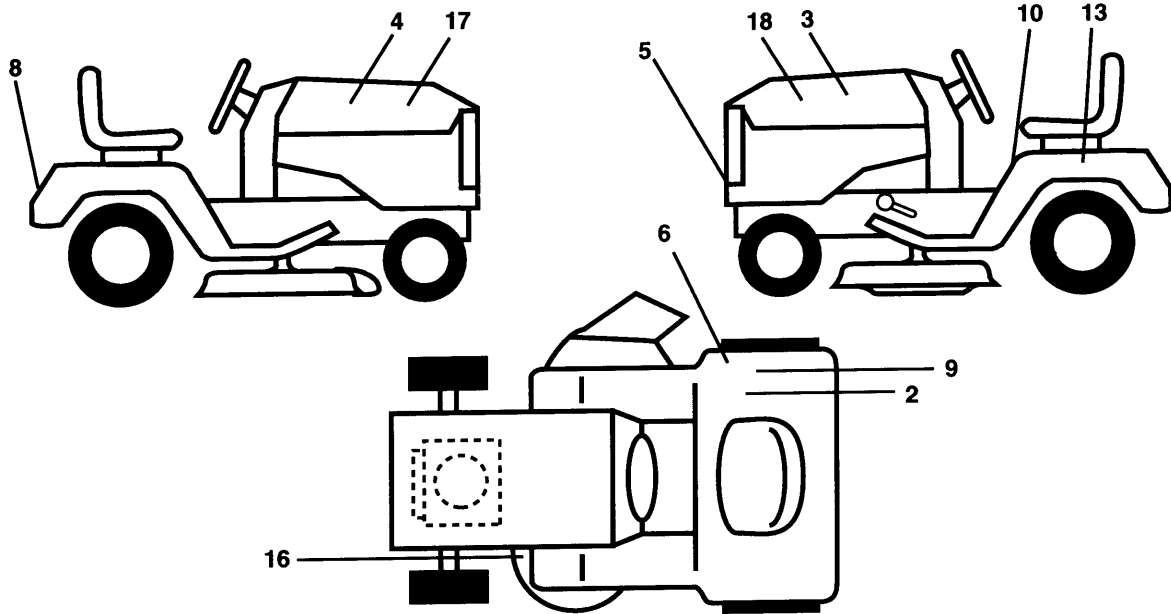

KEY NO.	PART NO.	DESCRIPTION
2	532 12 61-87	Decal, 100 DBA Cert. Dutch/French
3	532 14 02-06	Decal, Hood, L. H.
4	532 14 02-05	Decal, Hood, R. H.
	532 14 02-13	Decal, Logo, Grille
8	532 13 15-82	Decal, Logo, Fender
16	532 13 68-30	Decal, V-Belt Schematic
17	532 14 01-99	Decal, Hood LT120
18	532 14 02-00	Decal, Hood LT120

WHEELS & TIRES

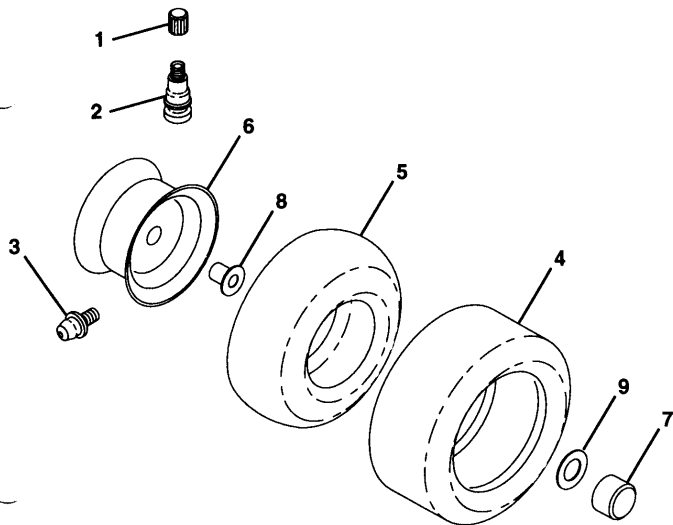

KEY NO.	PART NO.	DESCRIPTION
1	532 05 91-92	Cap, Valve
2	532 06 51-39	Stem, Valve
3	532 12 49-57	Fitting, Grease\ (Front Wheels Only)
4	532 12 34-10	Tire Front LT 100/
4	532 10 62-30	Tire Rear LT 100/
4	532 13 74-22	Tire, Front LT 112/120
4	532 13 27-03	Tire, Front LT 112/120
5	532 05 99-04	Tube, Front (Optional Service Items Only)
5	532 00 81-34	Tube, Rear (Optional Service Items Only)
6	532 14 02-98	Rim, Front
6	532 14 04-53	Rim, Rear
7	532 10 47-57	Cap, Hub
8	532 12 49-59	Bearing Flange
9	532 12 17-48	Washer 25/32 x 1-5/8 x 16 Ga.

NOTE: All component dimensions given in U.S. inches
1 inch = 25.4 mm

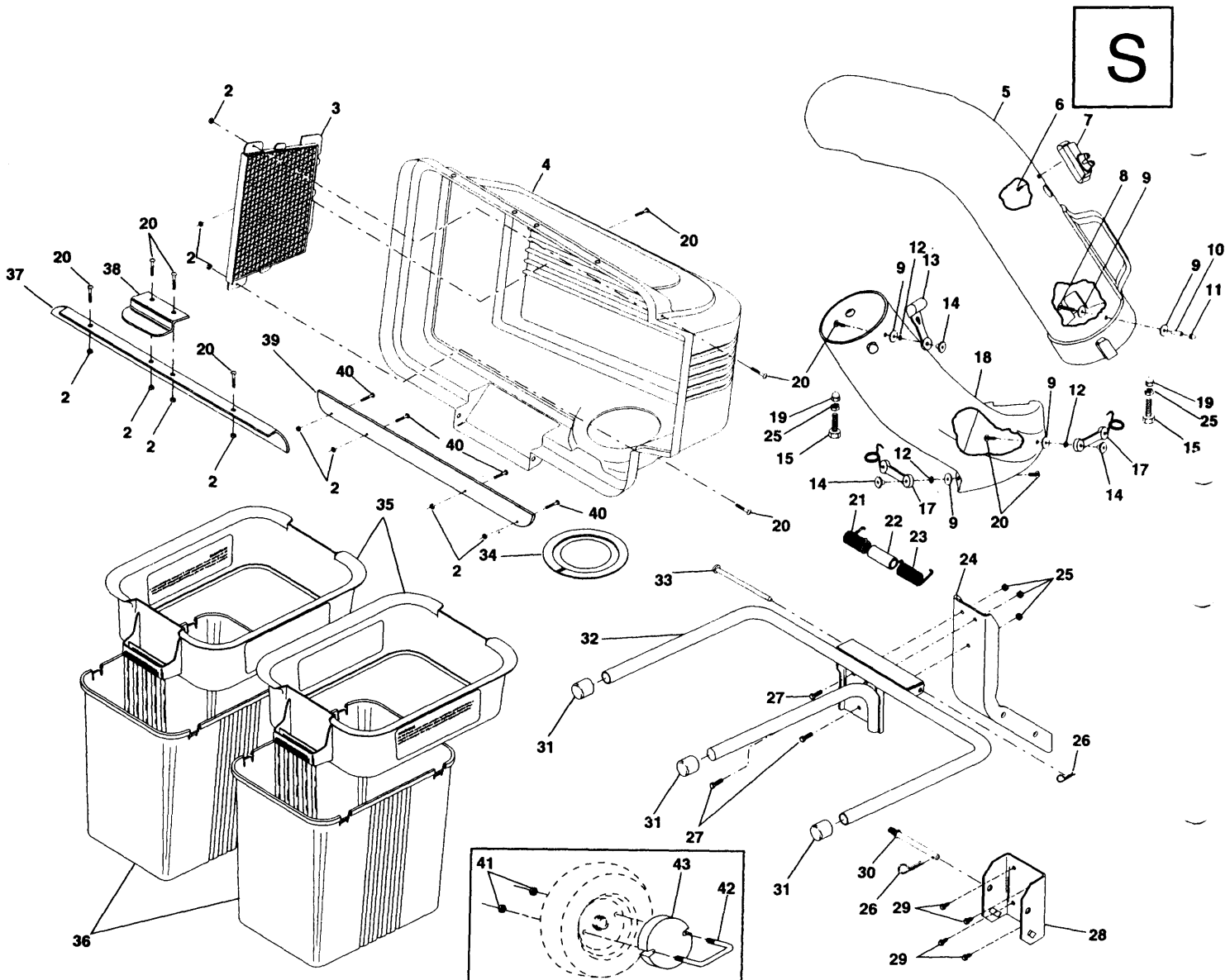

KEY NO PART NO. DESCRIPTION

KEY NO. PART NO. DESCRIPTION

2	5320691-80	Locknut #10-24
3	532 12 75-33	Screen, Cover
4	532 14 06-54	Cover
5	532 12 85-98	Chute, Upper
6	818 02 10-08	Screw, Special
7	532 14 05-72	Indicator, Dump Bag
8	532 08 71-75	Screw, # 10-24 x 1-1/8
9	734 11 46-01	Washer 3/16 x 3/4 x 16 Ga
10	532 00 72-06	Spacer, Split
11	532 06 08-67	Nut, Acorn # 10-24
12	810 07 10-00	Washer, lock
13	532 10 98-08	Latch, Chute
14	532 12 50-04	Nut, Weld
15	874 93 05-16	Bolt, Hex 5/16-18 x 1
17	532 13 07-58	Latch Assy., Bagger
18	532 12 85-99	Chute, Lower
19	532 13 38-41	Nut, Acorn 5/16-18
20	874 29 10-10	Screw # 10-24 x 5/8
21	532 13 27-96	Spring, Cover L.H. (black)
22	532 13 32-35	Spacer, Cover
23	532 13 29-83	Spring, Cover R.H. (grey)

24	532 12 77-20	Post, Support
25	873 22 05-00	Locknut 5/16 x 13
26	532 12 46-70	Spring, Retainer
27	874 76 05-12	Bolt, Hex 5/16-18 x 3/4
28	532 13 08-89	Bracket, Mounting
29	817 49 05-08	Screw, Thread Rolling 5/16-18 x 1/2
30	532 13 11-37	Pin, Support Post
31	532 13 44-96	Cap, Tubing End
32	532 12 69-19	Bagger, Frame
33	532 12 86-00	Pin, Hinge
34	532 12 75-34	Gasket, Cover
35	532 12 95-85	Container, Top
36	532 12 95-86	Container, Bottom, Hard
36	532 13 24-31	Container, Bottom, Soft
37	532 13 22-56	Seal, Cover
38	532 13 08-95	Latch Handle, Cover
39	532 13 54-95	Strip, Seal
40	874 19 10-08	Screw # 10-24 x 1/2
41	873 80 06-00	Locknut 3/8-16
42	532 13 70-31	U-Bolt
43	532 12 36-35	Weight Wheel