

## K960

Reservdelar

Spare parts

Ersatzteile

Pieces de rechange

Piezas de repuesto

Ricambi

Peças sobresselente

**A** K960

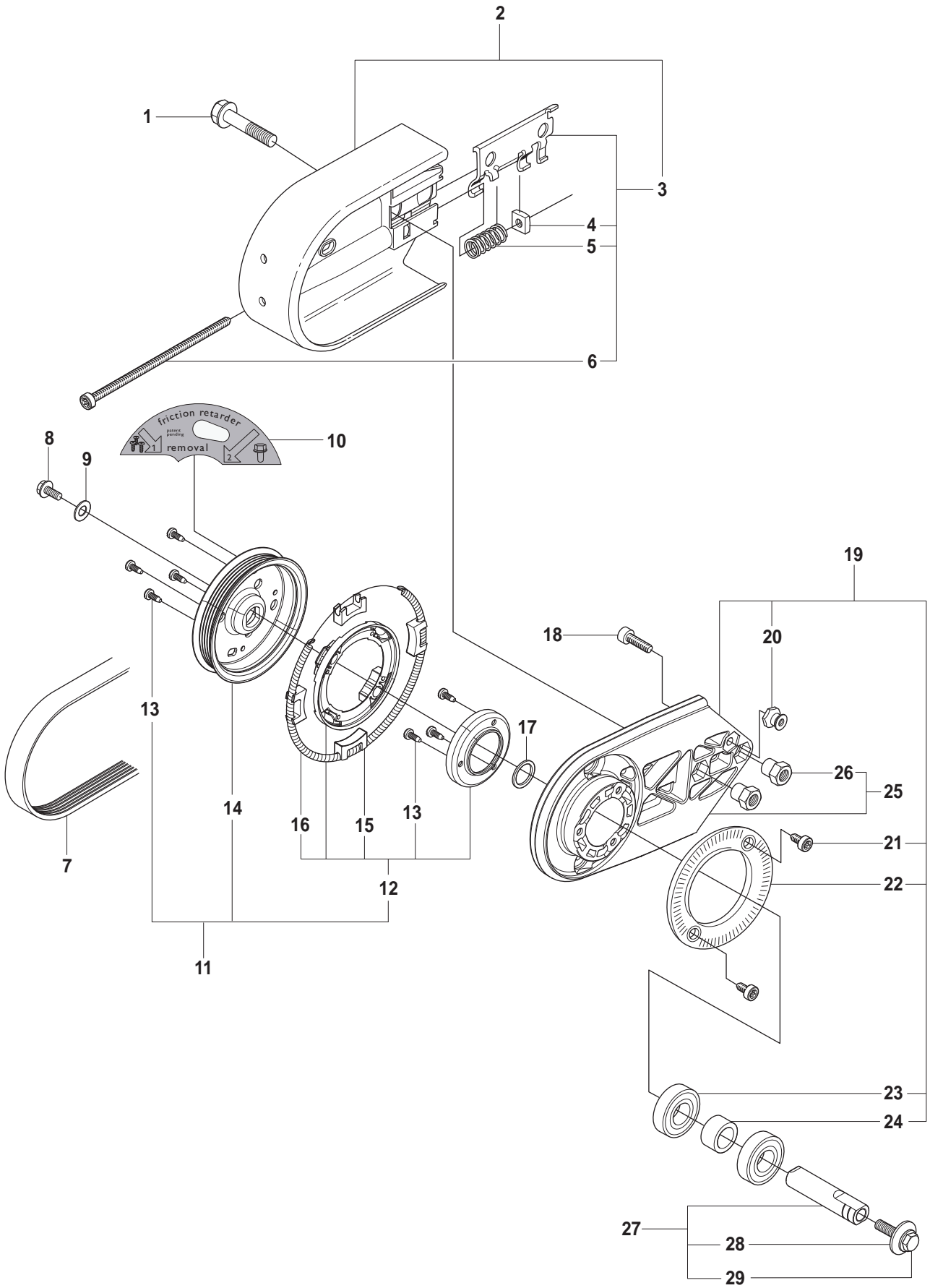

**Page A**  
**K960**

Pos.	Part No.	Description	Quantity	Notes	New Part
1	506 28 44-01	COLLAR SCREW	2		
2	506 39 36-02	BELT GUARD	1	Incl. 3	
3	506 26 66-04	BELT TENSIONER ASSY	1	Incl. 4, 5, 6	
4	506 40 93-01	NUT	1		
5	506 26 68-01	COMPRESSION SPRING	1		
6	503 20 72-05	SCREW	1		
7	544 90 84-03	BELT	1	12", 14"	
7	544 90 84-04	BELT	1	16"	
8	503 20 00-45	SCREW	1		
9	503 23 01-16	WASHER STEEL	1		
10	502 47 04-01	LABEL	1		
11	504 03 70-01	PULLEY	1	Incl. 12 - 16	
12	504 03 70-03	PULLEY	1	Incl. 13, 15, 16	
13	503 21 28-10	SCREW	7		
14	544 44 06-01	PULLEY	1		
15	544 44 04-01	BRAKE SHOE	4		
16	544 44 10-01	DRAW SPRING	1		
17	503 23 01-04	WASHER STEEL	1		
18	725 53 29-55	SCREW	1		
19	506 39 42-05	BEARING HOUSING	1	Incl. 20 - 24	
20	506 14 32-01	TORSION STOP	1		
21	503 21 53-10	SCREW	2		
22	506 28 84-01	SCREEN PATTERN FLANG	1		
23	503 25 21-01	BALL BEARING	2		
24	506 07 08-01	SPACING SLEEVE	1		
25	506 39 42-11	BEARING HOUSING	1	Incl. 26	
26	506 28 73-01	NUT	2		
27	506 29 83-63	SHAFT	1	Incl. 28, 29	
28	506 13 95-11	WASHER	1		
29	506 13 96-01	COLLAR SCREW	1		

**B** K960

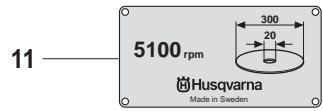
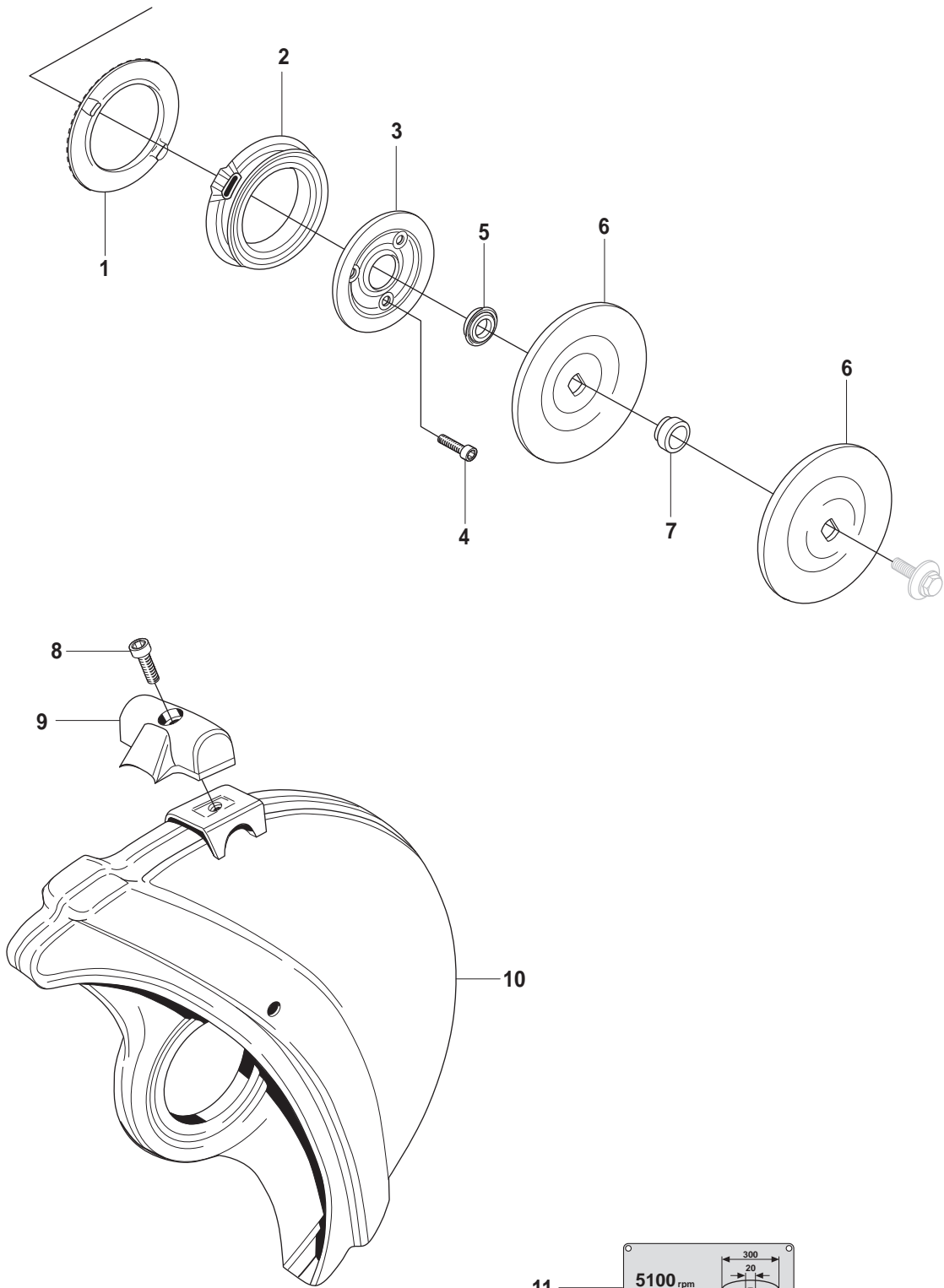

**Page B**  
**K960**

Pos.	Part No.	Description	Quantity	Notes	New Part
1	506 26 64-01	RATCHET FLANGE	1		
2	506 26 63-02	LINING	1		
3	506 26 65-01	FLANGE	1		
4	725 53 29-55	SCREW	3		
5	506 32 48-01	SUPPORT FLANGE	3		
6	506 02 87-01	FLANGE WASHER	1	Diam 105	
6	506 07 09-01	FLANGE WASHER	1	Diam 116	
7	506 37 96-20	BUSHING	1	Diam 20	
7	506 37 96-22	BUSHING	1	Diam 22,2	
7	506 37 96-25	BUSHING	1	Diam 25	
7	506 02 88-30	BUSHING	1	Diam 30,5	
8	725 53 31-55	SCREW	1		
9	506 34 46-02	HANDLE	1		
10	506 34 05-02	WHEEL GUARD ASSY	1	12". Incl. 2, 9, 10	
10	506 34 05-04	WHEEL GUARD ASSY	1	14". Incl. 2, 9, 10	
10	506 34 05-06	WHEEL GUARD ASSY	1	16". Incl. 2, 9, 10	
11	506 28 41-04	LABEL	1	12". Diam 1"	
11	506 28 41-02	LABEL	1	12". Diam 20 mm	
11	506 28 41-14	LABEL	1	14". Diam 1"	
11	506 28 41-12	LABEL	1	14". Diam 20 mm	
11	506 28 41-24	LABEL	1	16". Diam 1"	
11	506 28 41 22	LABEL	1	16". Diam 20 mm	

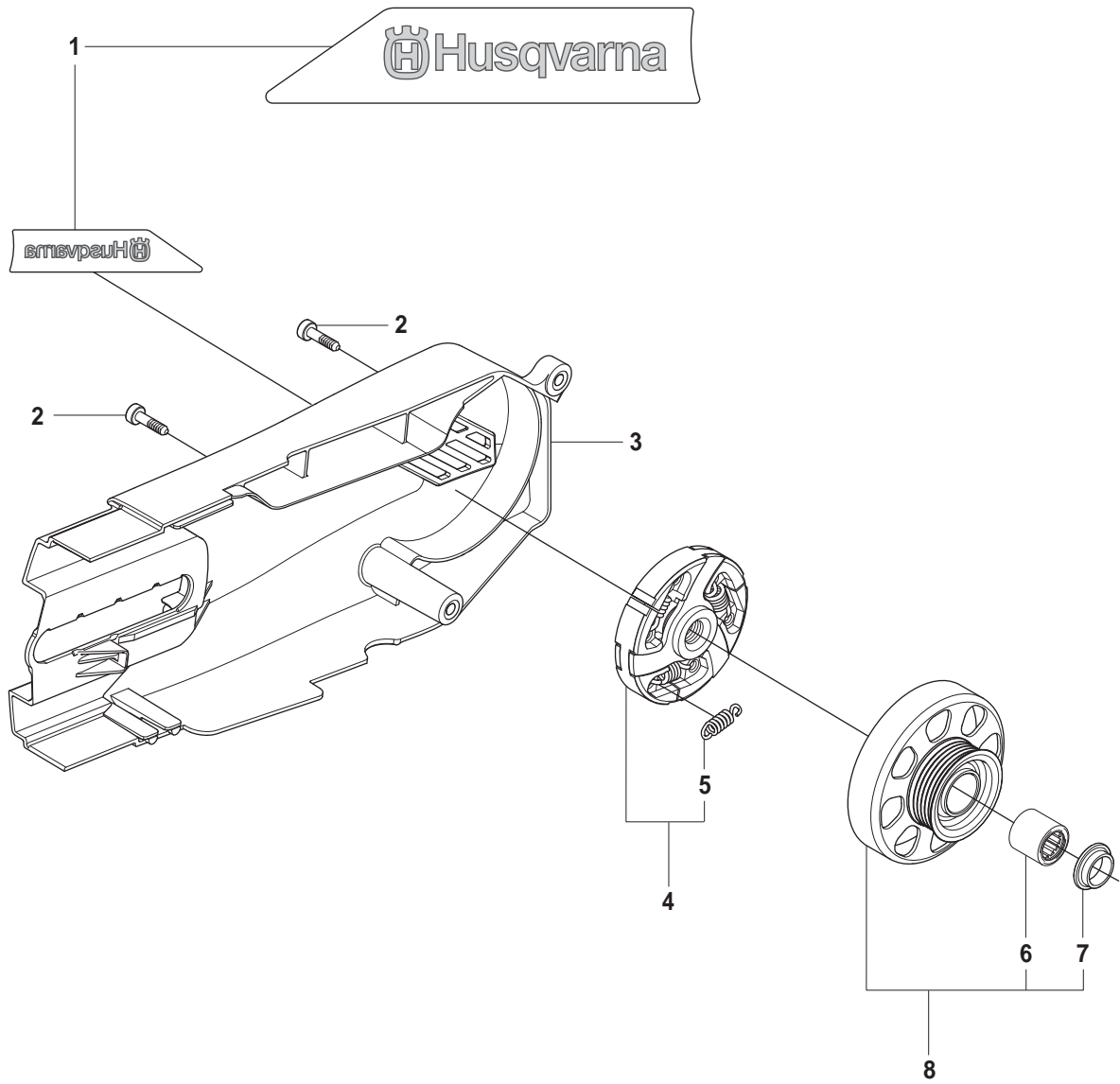

**Page C**  
**K960**

<b>Pos.</b>	<b>Part No.</b>	<b>Description</b>	<b>Quantity</b>	<b>Notes</b>	<b>New Part</b>
1	544 93 31-01	LABEL	1		
2	503 21 53-21	SCREW	2		
3	544 09 65-02	BELT GUARD	1		
4	503 70 15-01	CLUTCH ASSY	1	Incl. 5	
5	503 14 51-01	CLUTCH SPRING	3		
6	505 30 24-15	NEEDLE BEARING	1		
7	506 39 30-01	WASHER	1		
8	506 37 83-02	DRIVING PULLEY ASSY	1	12", 14". Incl. 6, 7	
8	544 37 66-01	DRIVING PULLEY ASSY	1	16". Incl. 6, 7	

**D** K960

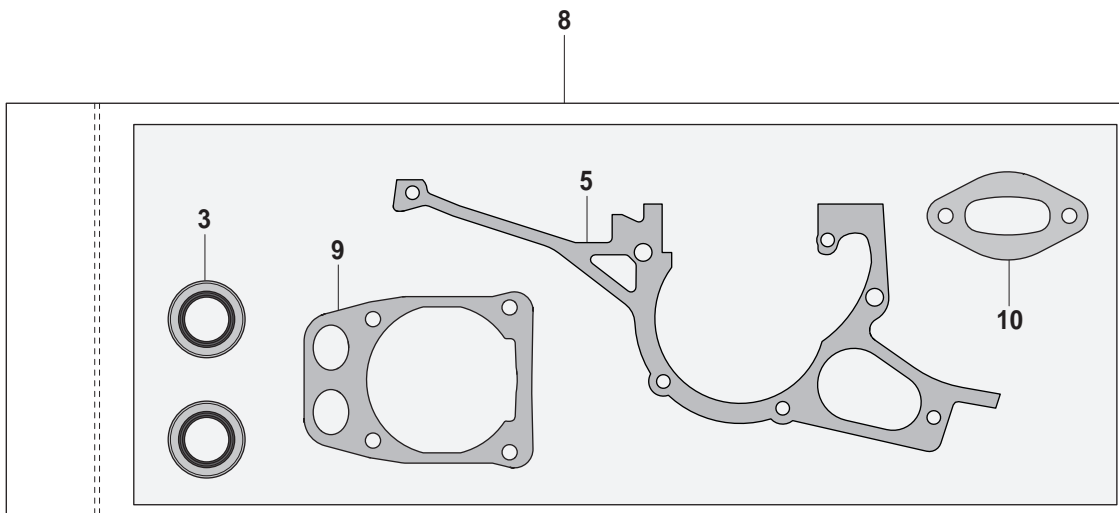
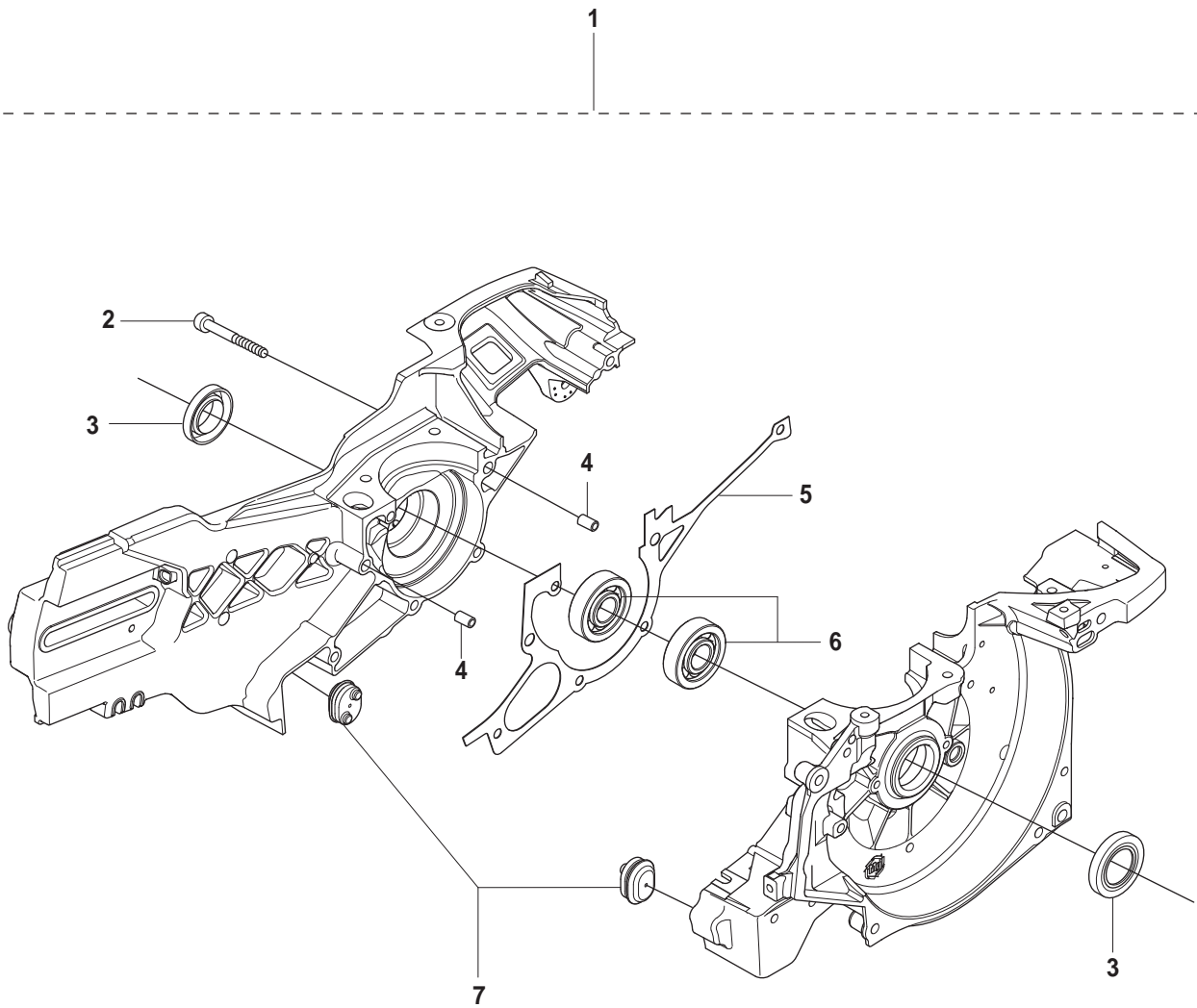



**Page D**  
**K960**

<b>Pos.</b>	<b>Part No.</b>	<b>Description</b>	<b>Quantity</b>	<b>Notes</b>	<b>New Part</b>
1	544 21 47-02	CRANKCASE ASSY	1	Incl. 2 - 8	
2	503 21 53-49	SCREW	7		
3	503 26 02-04	SEALING RING	2		
4	501 27 08-01	GUIDE BUSHING	2		
5	506 41 39-01	GASKET	1		
6	503 25 00-02	BALL BEARING	2		
7	544 89 54-01	RUBBER BUSHING	2		
8	544 22 98-01	GASKET KIT	1	Incl. 3, 5, 9, 10	
9	506 41 40-01	GASKET	1		
10	506 37 81-01	GASKET MUFFLER	1		

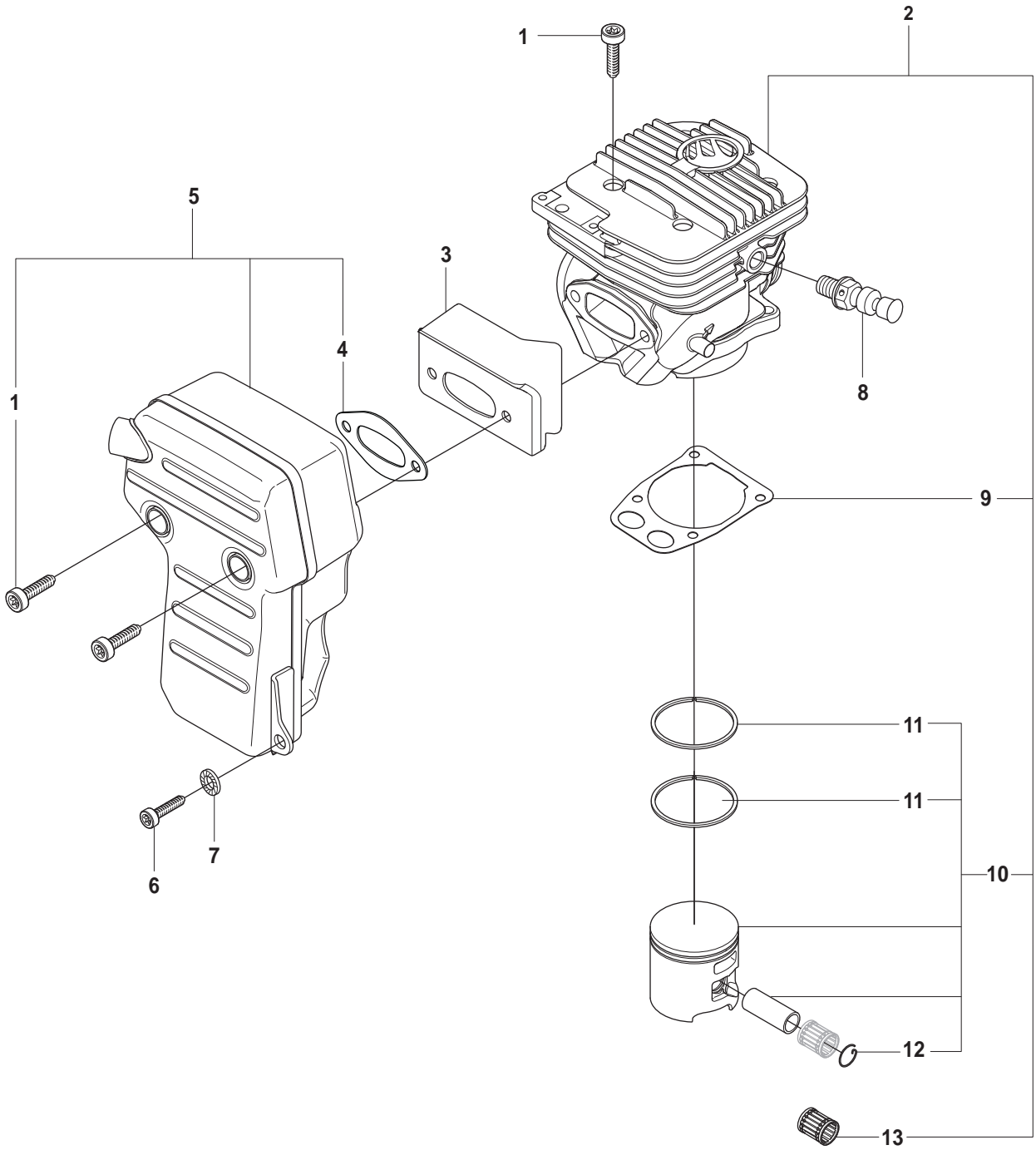

**Page E**  
**K960**

<b>Pos.</b>	<b>Part No.</b>	<b>Description</b>	<b>Quantity</b>	<b>Notes</b>	<b>New Part</b>
1	544 21 84-01	SCREW	6		
2	544 93 56-02	CYLINDER ASSY	1	Incl. 9, 10, 13	
3	544 21 52-01	HEAT DEFLECTOR	1		
4	506 37 81-01	GASKET MUFFLER	1		
5	506 37 28-03	MUFFLER	1	Incl. 1, 4	
6	503 21 53-25	SCREW	1		
7	503 23 04-02	WASHER	1		
8	503 66 56-01	DECOMPRESSION VALVE	1		
9	506 41 40-01	GASKET	1		
10	506 41 32-02	PISTON	1	Incl. 11, 12	
11	503 28 90-35	PISTON RING	2		
12	737 44 13-00	CIRCLIP	2		
13	503 25 61-01	NEEDLE BEARING	1		

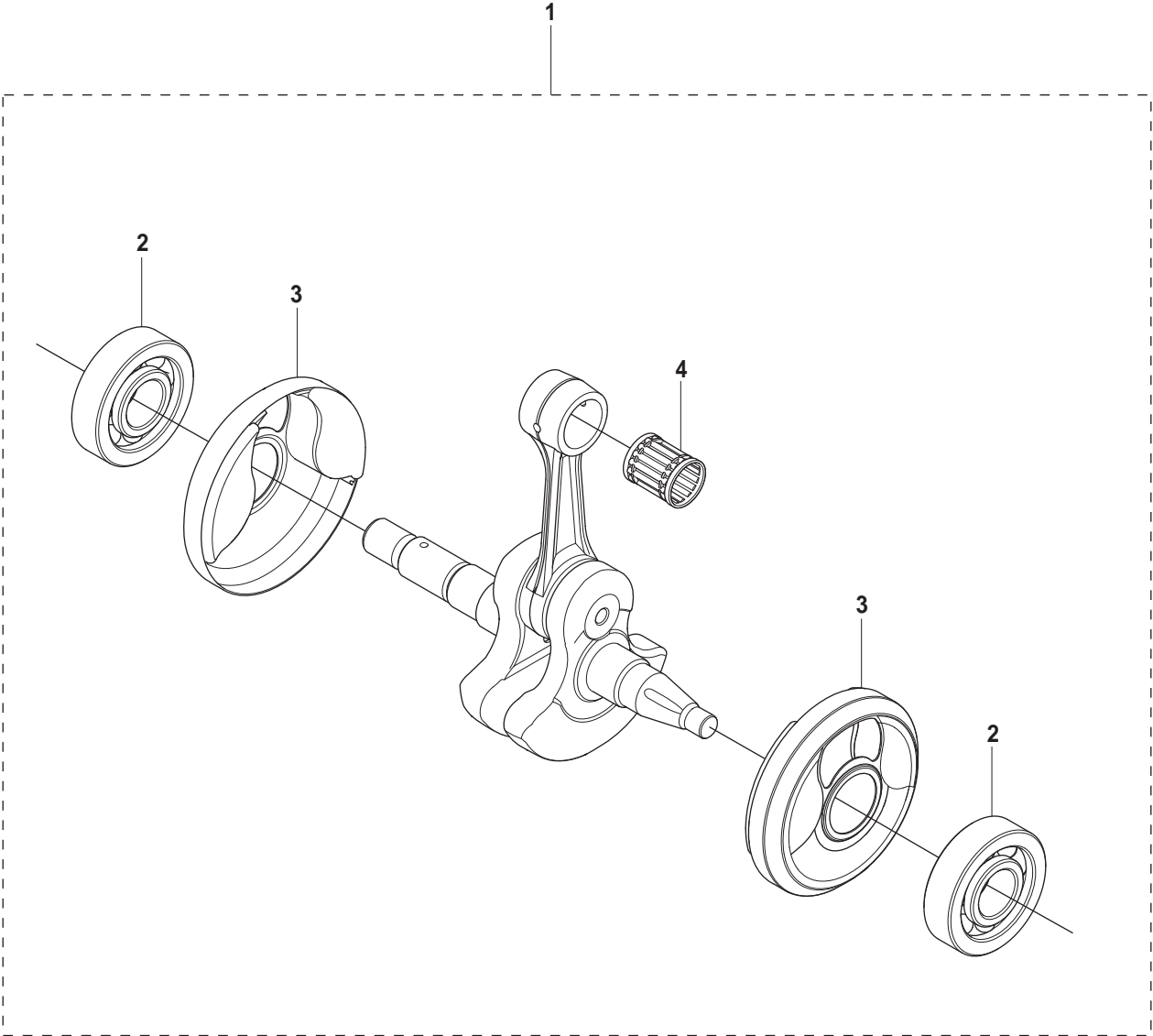

**Page F**  
**K960**

<b>Pos.</b>	<b>Part No.</b>	<b>Description</b>	<b>Quantity</b>	<b>Notes</b>	<b>New Part</b>
1	544 98 39-01	CRANKSHAFT ASSY	1	Incl. 2 - 4	
2	503 25 00-02	BALL BEARING	2		
3	506 41 44-01	CUP	2		
4	503 25 61-01	NEEDLE BEARING	1		

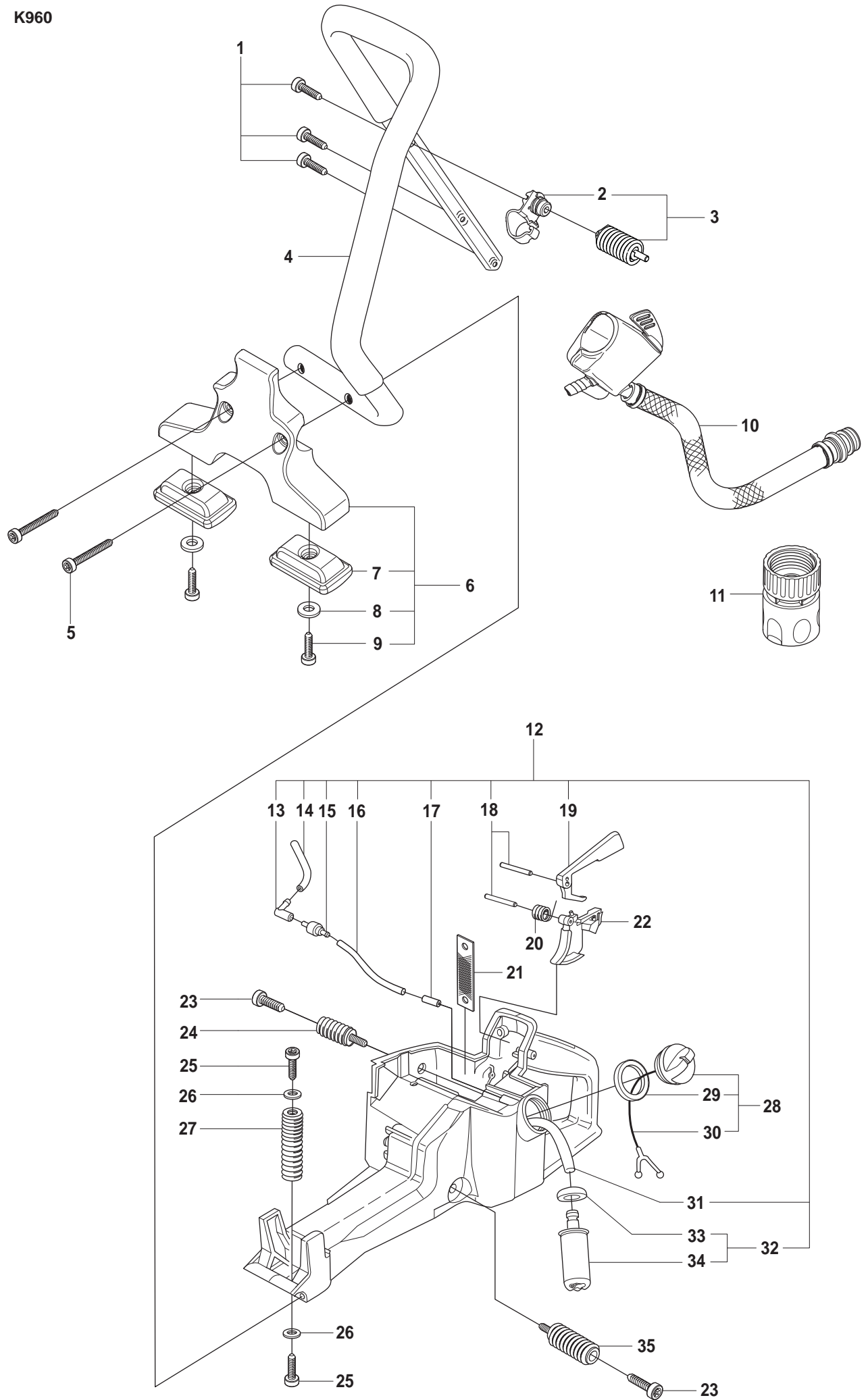

**Page G**  
**K960**

Pos.	Part No.	Description	Quantity	Notes	New Part
1	503 21 54-20	SCREW	3		
2	544 02 08-02	SPRING RETAINER	1		
3	506 38 91-03	VIB.INSULATOR	1	Incl. 2	
4	544 45 68-01	HANDLE	1		
5	503 21 54-45	SCREW	2		
7	544 81 16-01	BASE GROUND SUPPORT	2		New Part
8	734 11 47-41	WASHER	2		New Part
9	503 21 53-12	SCREW	2		New Part
10	506 38 59-04	HOSE	1		
11	503 26 60-02	COUPLER	1		
12	544 89 20-06	FUEL TANK	1	Incl. 13 - 19, 28, 32	
13	503 45 46-01	CONNECTION BEND	1		
14	501 76 83-05	FUEL HOSE	1		
15	506 23 61-01	TANK VENT	1		
16	544 32 49-32	FUEL HOSE	1		
17	506 28 95-01	NIPPLE	1		
18	720 12 40-20	PARALLEL PIN	2		
19	506 22 28-02	THROTTLE LOCKOUT	1		
20	506 22 29-01	SPRING THROTTLE TRIG	1		
21	544 23 82-01	BAND	1		
22	506 22 27-03	THROTTLE TRIGGER	1		
23	544 06 12-01	SCREW	1		
24	537 21 03-09	ANTIVIB ELEMENT	1		
25	503 21 53-16	SCREW	2		
26	503 23 00-11	WASHER STEEL	2		
27	503 46 85-01	ANTIVIB ELEMENT	1		
28	506 25 59-03	TANK CAP ASSY	1	Incl. 29, 30	
29	506 29 21-01	GASKET	1		
30	503 57 89-01	TANK CAP HOLDER	1		
32	506 26 41-11	FUEL FILTER	1	Incl. 33, 34	
31	544 32 50-02	FUEL HOSE	1		
33	506 27 11-01	HOSE CLAMP	1		
34	506 26 41-01	FUEL FILTER	1		
35	544 38 31-02	SPRING	1		

1

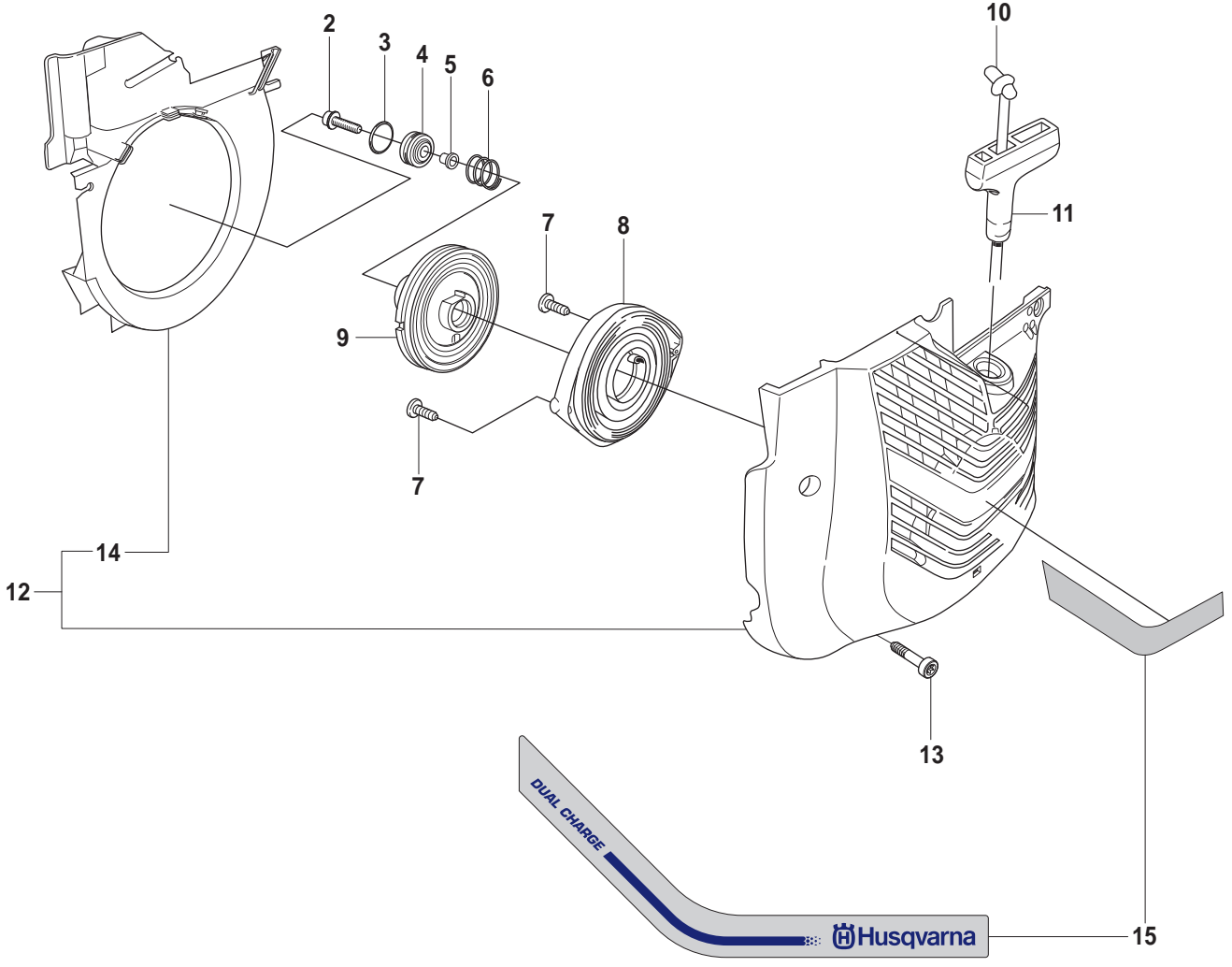



**Page H**  
**K960**

<b>Pos.</b>	<b>Part No.</b>	<b>Description</b>	<b>Quantity</b>	<b>Notes</b>	<b>New Part</b>
1	506 23 59-13	STARTER	1	Incl. 2 - 15	
2	503 21 07-22	SCREW	1		
3	740 43 13-00	O-RING	1		
4	506 25 14-01	GROMMET	1		
5	506 26 31-01	SPACING SLEEVE	1		
6	506 25 30-01	COMPRESSION SPRING	1		
7	503 21 28-10	SCREW	2		
8	506 25 89-01	RECOIL SPRING	1		
9	506 25 81-02	STARTER PULLEY	1		
10	506 33 56-15	STARTER CORD	1		
10	506 33 56-50	STARTER CORD	1	50 m Coil	
11	503 12 79-01	STARTER HANDLE	1		
12	506 33 72-04	STARTER COVER	1	Incl. 14	
13	503 21 53-21	SCREW	4		
14	544 28 75-01	COOLING AIR CONDUCTOR	1		
15	506 27 23-03	LABEL	1		

**J**

K960

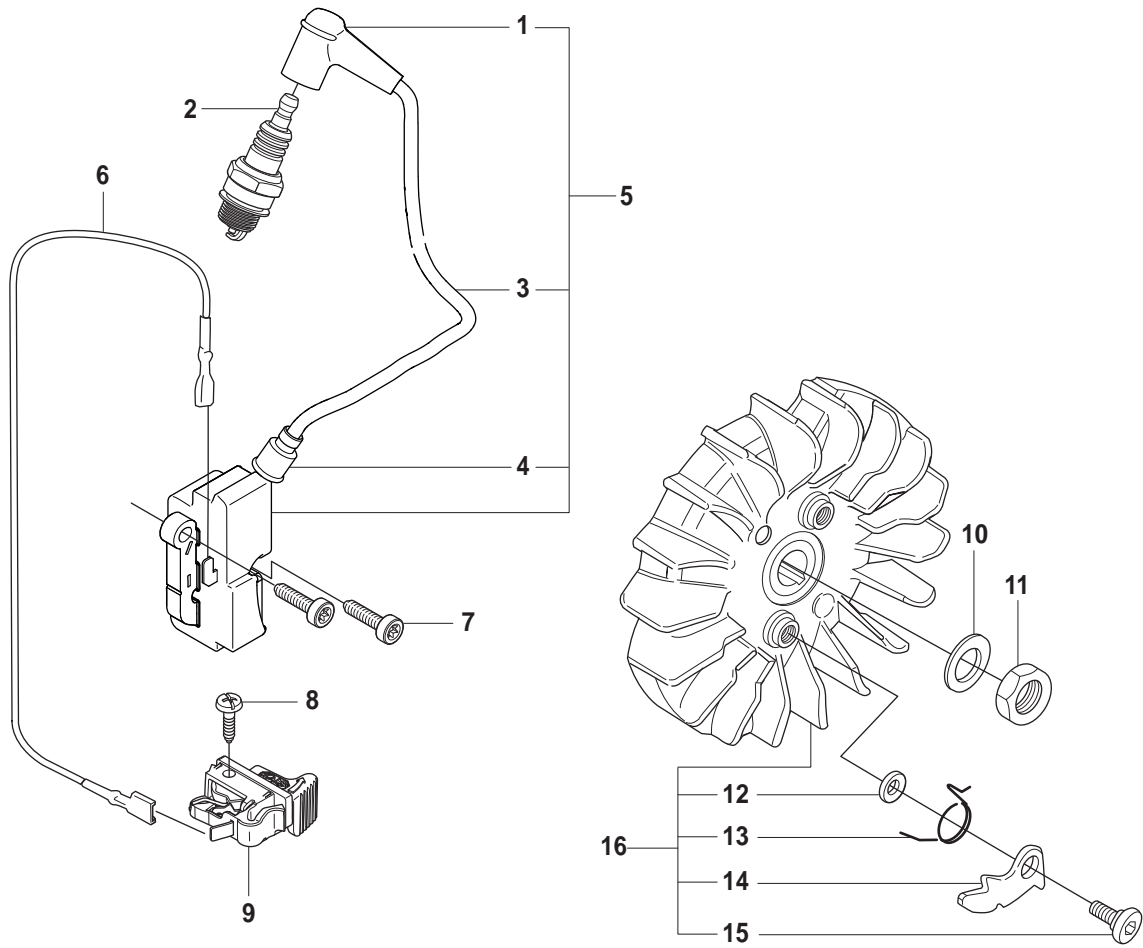

**Page J**  
**K960**

<b>Pos.</b>	<b>Part No.</b>	<b>Description</b>	<b>Quantity</b>	<b>Notes</b>	<b>New Part</b>
1	501 48 54-02	SPARK PLUG CAP	1		
2	503 23 51-09	SPARK PLUG	1	RCJ 6Y	
3	506 38 78-34	IGNITION CABLE	1		
4	505 27 75-16	INSULATING CAP	1		
5	544 04 75-03	IGNITION MODULE	1	Incl. 1, 3, 4	
6	501 83 98-01	CABLE	1		
7	503 21 53-20	SCREW	2		
8	503 21 28-06	SCREW	1		
9	506 31 86-02	STOP SWITCH	1		
10	503 23 01-01	WASHER STEEL	1		
11	503 22 10-11	NUT	1		
12	503 23 00-42	WASHER STEEL	2		
13	501 63 48-01	SPRING	2		
14	501 67 32-03	PAWL	2		
15	501 81 99-01	SCREW	2		
16	506 27 27-02	FLYWHEEL	1	Incl. 12 - 15	

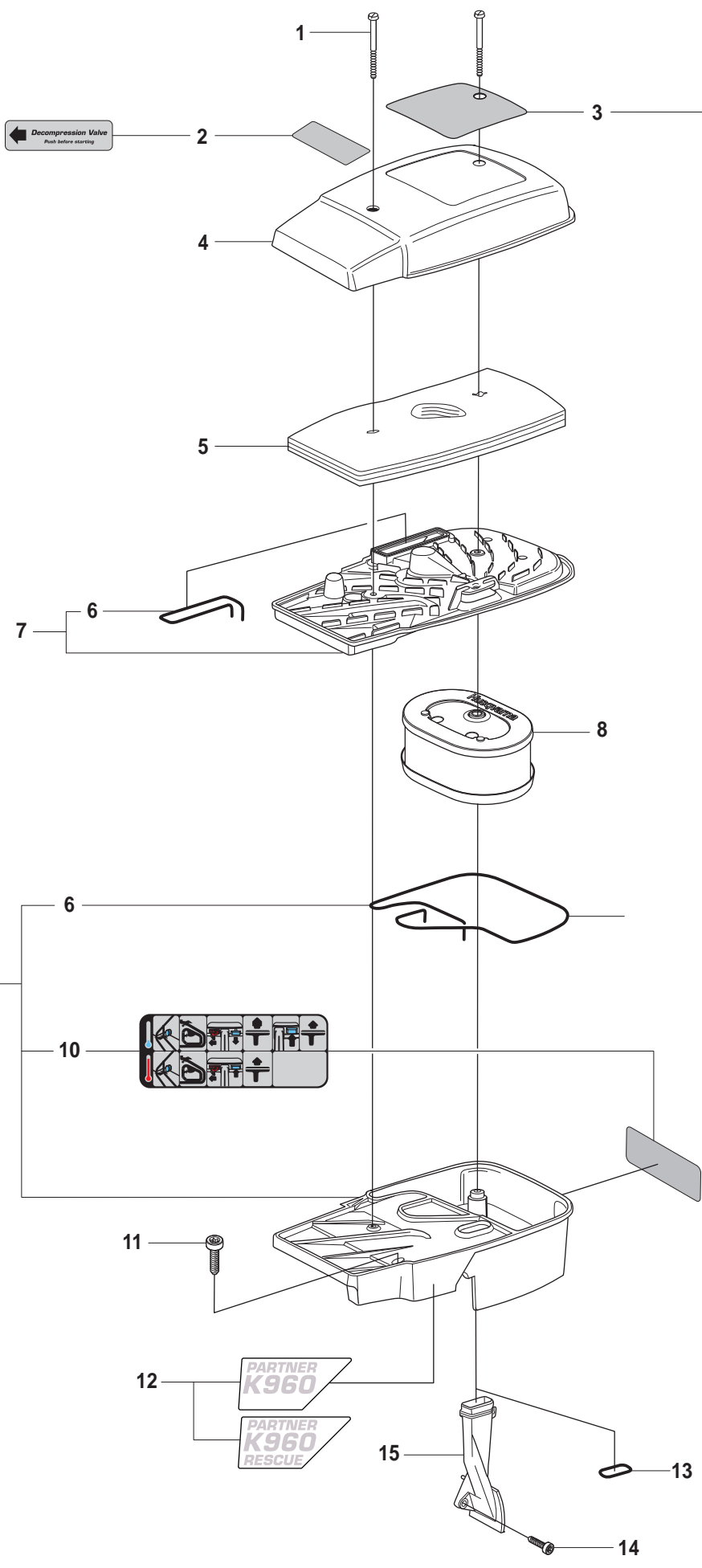

**Page K**  
**K960**

<b>Pos.</b>	<b>Part No.</b>	<b>Description</b>	<b>Quantity</b>	<b>Notes</b>	<b>New Part</b>
1	503 21 53-49	SCREW	2		
2	544 87 46-01	LABEL	1		
3	544 87 44-02	LABEL	1	CE	
3	544 87 44-04	LABEL	1	EPA USA	
3	544 87 44-05	LABEL	1	EPA Canada	
4	506 22 17-02	AIR FILTER COVER	1		
5	506 23 19-01	PREFILTER	1		
6	506 28 39-30	SEALING	2		
7	506 22 18-15	FILTER BOTTOM	1	Incl. 6	
8	506 34 70-02	AIR FILTER	1		
9	544 89 14-04	CYLINDER COVER ASSY	1	Incl. 6, 10	
10	506 24 39-02	LABEL	1		
11	503 21 53-30	SCREW	3		
12	544 89 07-05	LABEL	1		
12	544 89 07-06	LABEL	1	Rescue	
13	740 48 20-03	O-RING	1		
14	501 98 10-01	SCREW	1		
15	506 22 94-01	AIR NOZZLE	1		



K960

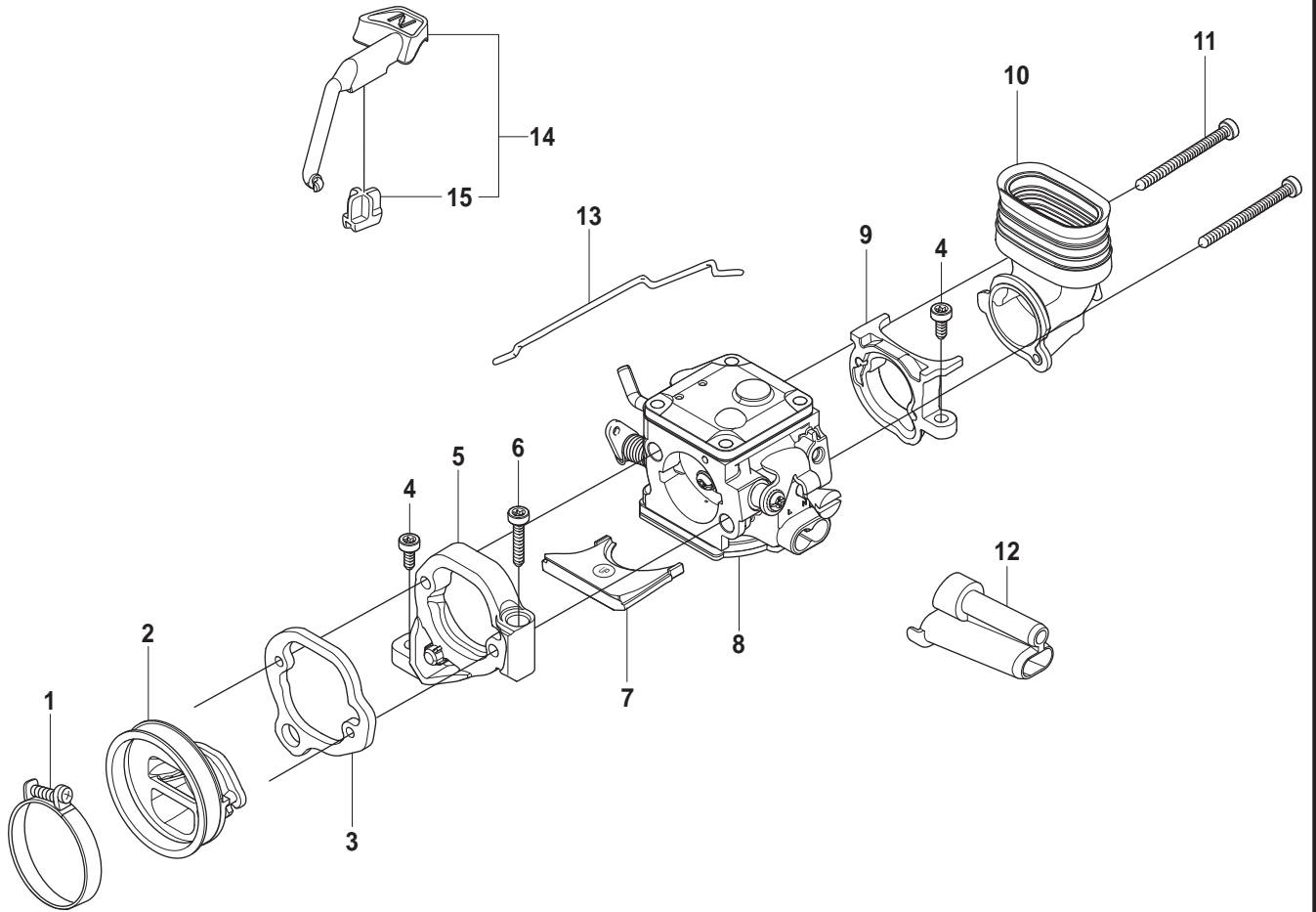

**Page L**  
**K960**

<b>Pos.</b>	<b>Part No.</b>	<b>Description</b>	<b>Quantity</b>	<b>Notes</b>	<b>New Part</b>
1	503 56 00-08	HOSE CLAMP	1		
2	506 41 41-01	INLET PIPE	1		
3	544 15 01-01	FLANGE	1		
4	503 21 53-16	SCREW	2		
5	544 11 39-01	CONSOLE	1		
6	503 21 53-30	SCREW	1		
7	506 41 42-01	PLATE	1		
8	502 62 32-01	CARBURETTOR	1	Walbro RWJ-2	New Part
9	544 11 17-01	FLANGE	1		
10	544 33 19-01	INLET BEND	1		
11	501 97 18-01	SCREW	2		
12	544 23 26-01	CHISEL GUIDE	1		
13	504 05 47-01	THROTTLE ROD	1		
14	506 23 20-11	CHOKE	1	Incl. 15	
15	506 27 25-01	WEAR PROTECTION	1		

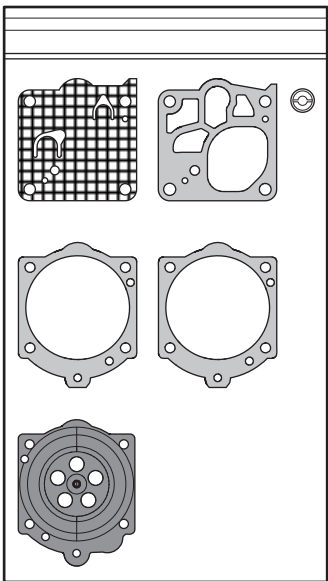
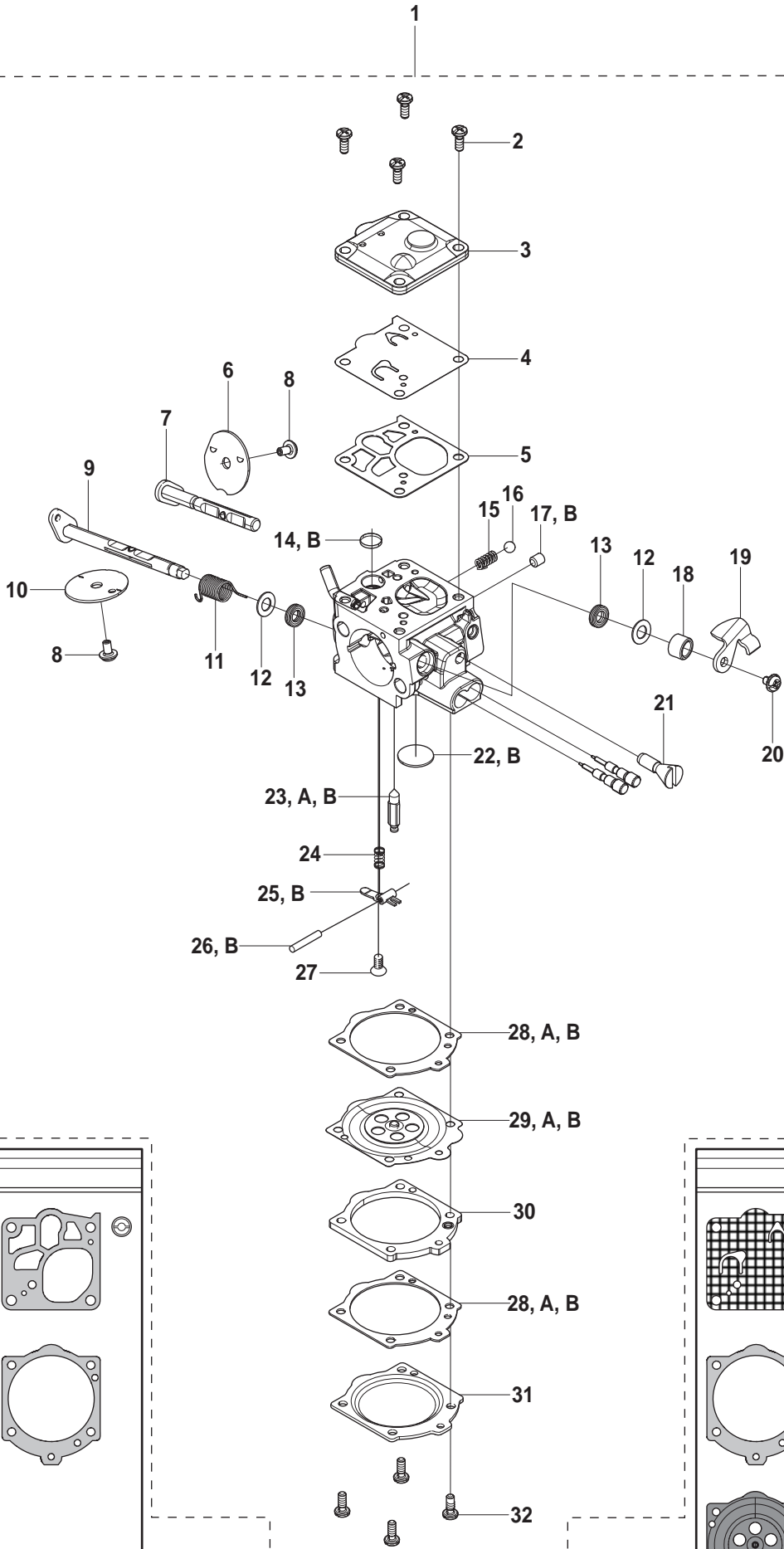

33, A

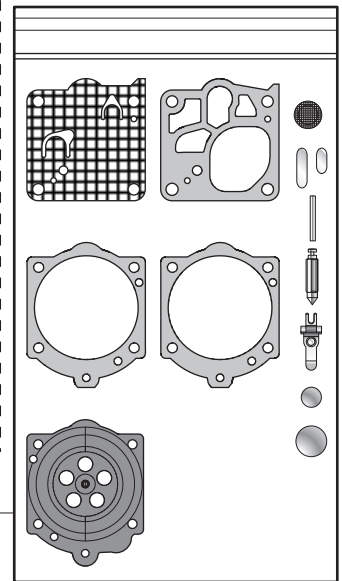

34, B



**Page M**  
**K960**

Pos.	Part No.	Description	Quantity	Notes	New Part
1	502 62 32-01	CARBURETTOR	1	Incl. 2 - 32	New Part
2	503 11 75-01	SCREW-PUMP COVER	4		
3	544 89 62-01	PUMP COVER	1		
4	544 89 72-01	DIAPHRAGM PUMP	1	A, B	
5	503 11 72-01	GASKET-PUMP	1	A, B	
6	504 13 52-01	VALVE	1		
7	544 89 67-01	SHAFT	1		
8	544 11 15-01	SCREW	2		
9	544 89 64-01	SHAFT	1		
10	504 13 53-01	VALVE	1		
11	544 95 68-01	SPRING	1		
12	505 31 67-48	WASHER	2		
13	503 56 45-01	SEAL-THROTTLE SHAFT	2		
14	501 66 61-01	SCREEN-INLET	1	B	
15	503 11 77-01	SPRING-CHOKE FRICT.	1		
16	503 11 71-01	BALL-CHOKE FRICTION	1		
17	530 03 51-57	PLUG	1		
18	537 00 26-01	SPACER	1		
19	544 89 60-01	LEVER	1		
20	501 46 87-01	SCREW	1		
21	544 89 76-01	SCREW	1		
22	503 57 41-01	PLUG-WELCH	1		
23	503 63 25-01	VALVE -INLET NEEDLE	1	A, B	
24	503 11 76-01	SPRING-METER.LEVER	1		
25	505 31 67-34	LEVER-METERING	1	B	
26	505 31 67-31	PIN-METERING LEVER	1	B	
27	505 31 67-17	SCREW-LEVER PIN	1		
28	544 89 71-01	GASKET	2	A, B	
29	544 89 74-01	DIAPHRAGM ASSY	1	A, B	
30	544 89 79-01	PLATE	1		
31	544 89 63-01	COVER	1		
32	537 00 20-01	SCREW	4		
33	502 44 58-01	GASKET KIT	1	Kit A. D10-RWJ	
34	502 44 59-01	REPAIR KIT	1	Kit B. K10-RWJ	

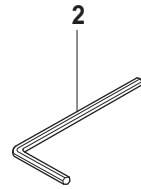
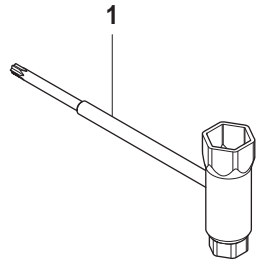

3

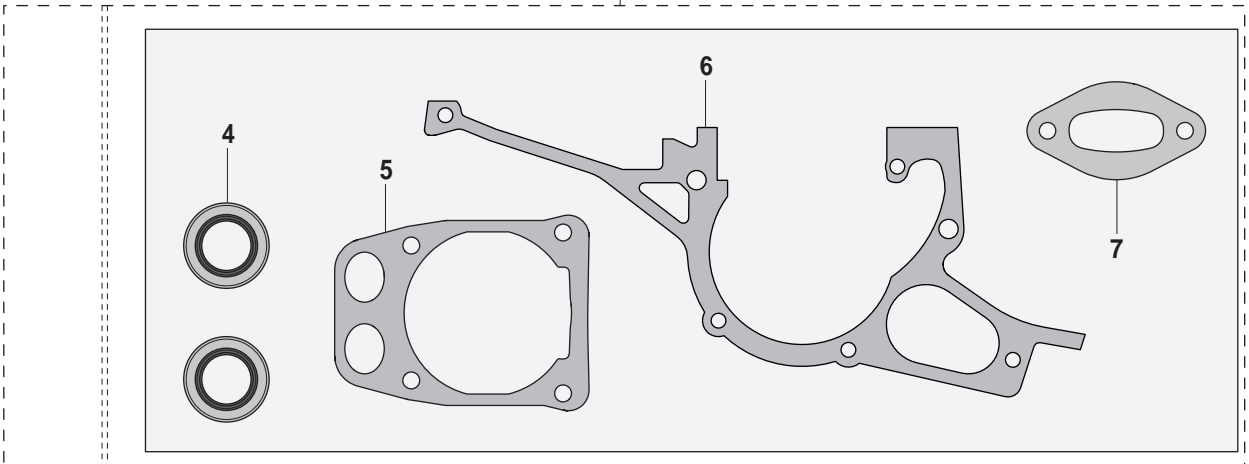

**Page N**  
**K960**

<b>Pos.</b>	<b>Part No.</b>	<b>Description</b>	<b>Quantity</b>	<b>Notes</b>	<b>New Part</b>
1	506 38 26-01	COMBINATION TOOL	1	Torx 27	
2	502 21 58-01	L-SPANNER	1	4 mm	
3	544 22 98-01	GASKET KIT	1	Incl. 4, 5, 6, 7	
4	503 26 02-04	SEALING RING	2		
5	506 41 40-01	GASKET	1		
6	506 41 39-01	GASKET	1		
7	506 37 81-01	GASKET MUFFLER	1		

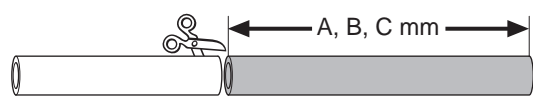
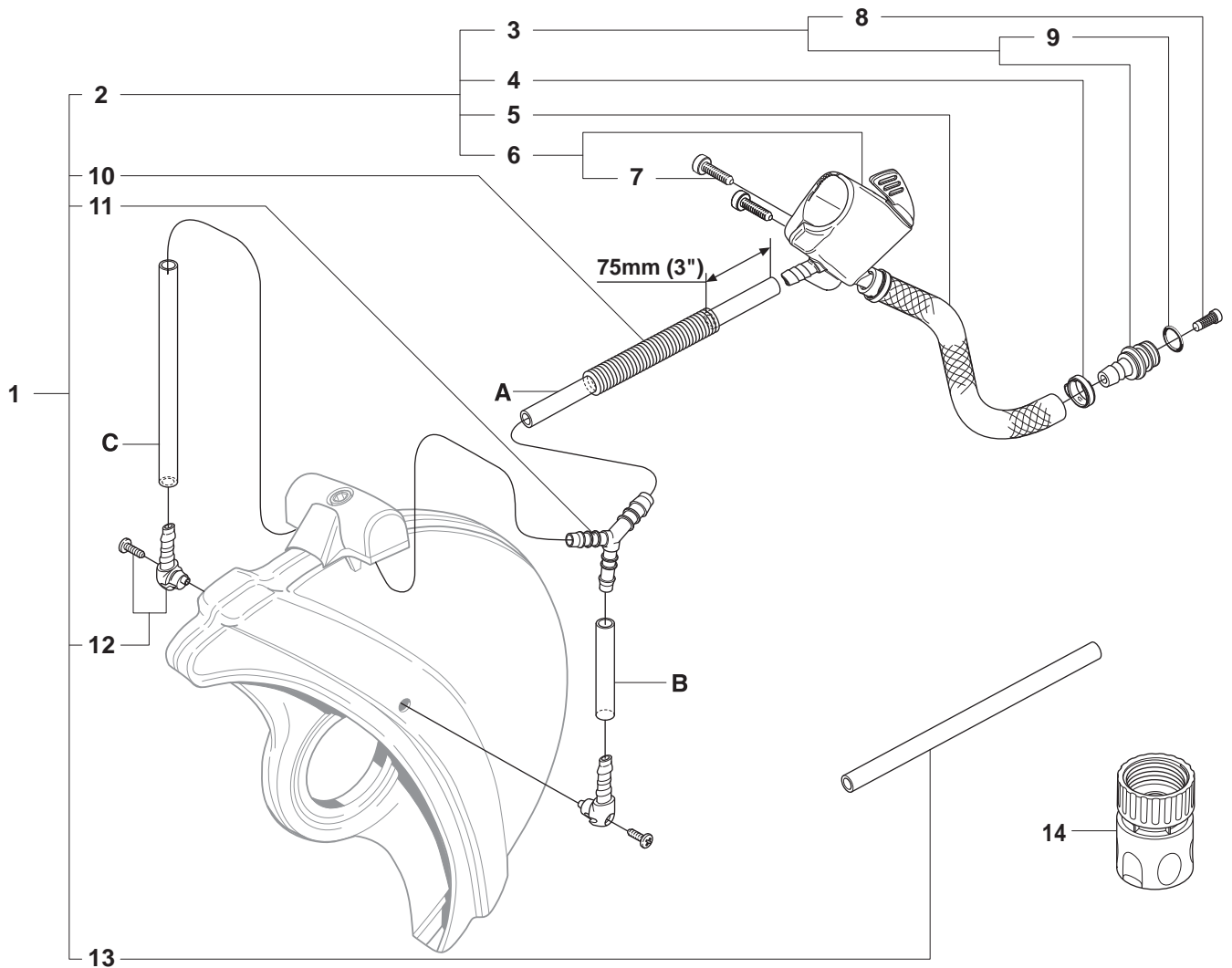

Product		A (mm)	B (mm)	C (mm)
K960	12"	240	240	45
	14"	240	280	45
	16"	270	360	45

**Page P**  
**K960**

<b>Pos.</b>	<b>Part No.</b>	<b>Description</b>	<b>Quantity</b>	<b>Notes</b>	<b>New Part</b>
1	544 00 31-02	WATER HOSE KIT	1	12", 14". Incl. 2, 10 - 13	
1	544 00 31-05	WATER HOSE KIT	1	16". Incl. 2, 11 - 13	
2	506 38 59-04	HOSE	1	Incl. 3 - 6	
3	506 29 57-02	NIPPLE	1	Incl. 7	
4	506 09 56-06	HOSE CLAMP	2		
5	506 09 75-02	HOSE	1	L=230 mm	
6	506 38 60-12	VALVE ASSY	1	Incl. 7	
7	503 21 54-20	SCREW	2		
8	506 29 88-01	FILTER	1	Incl. 9	
9	503 26 30-21	O-RING	1		
10	506 35 27-01	PROTECTIVE SPRING	1	16" only	
11	506 29 56-01	NIPPLE	2		
12	506 32 87-01	Y-TUBE	1		
13	506 09 58-24	HOSE	1	800 mm	
14	503 26 60-02	COUPLER	1		

**Q** K960

**K12 FD  
FIRE-RESCUE**

**Rescue**

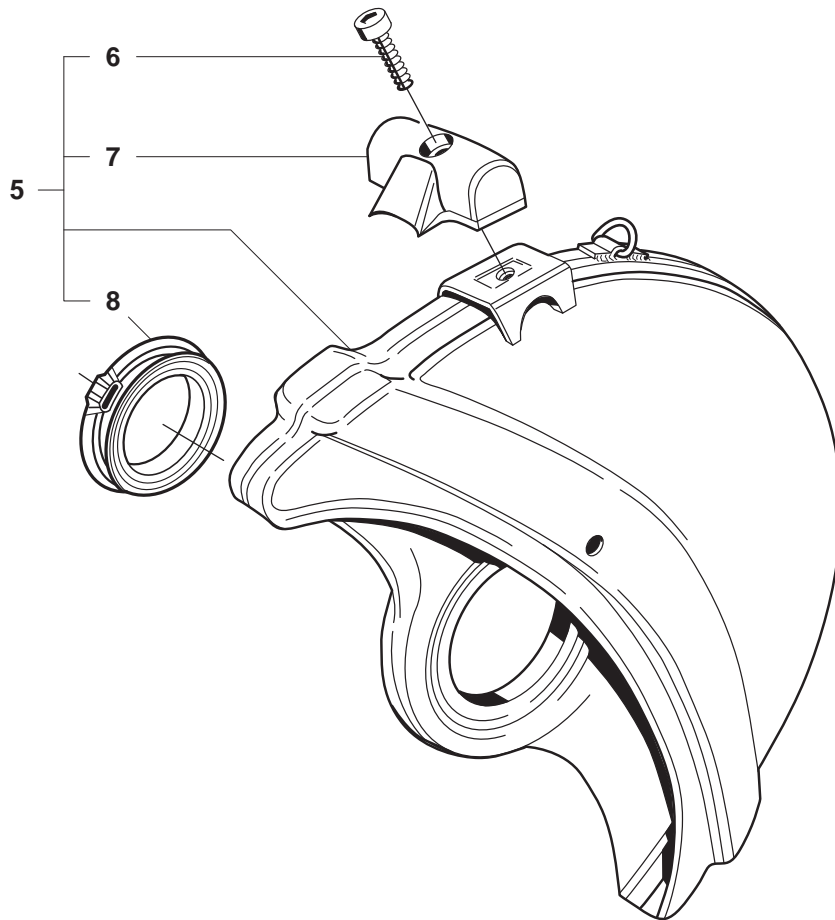
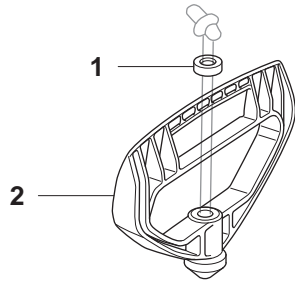

9 — **Husqvarna Rescue**  
max 5100 rpm  
Ø25.4 (Ø1"), Ø300 (Ø12")

10 — **⚠ ATTENTION ⚠**  
This product has been modified for use by  
trained fire rescue personnel only.

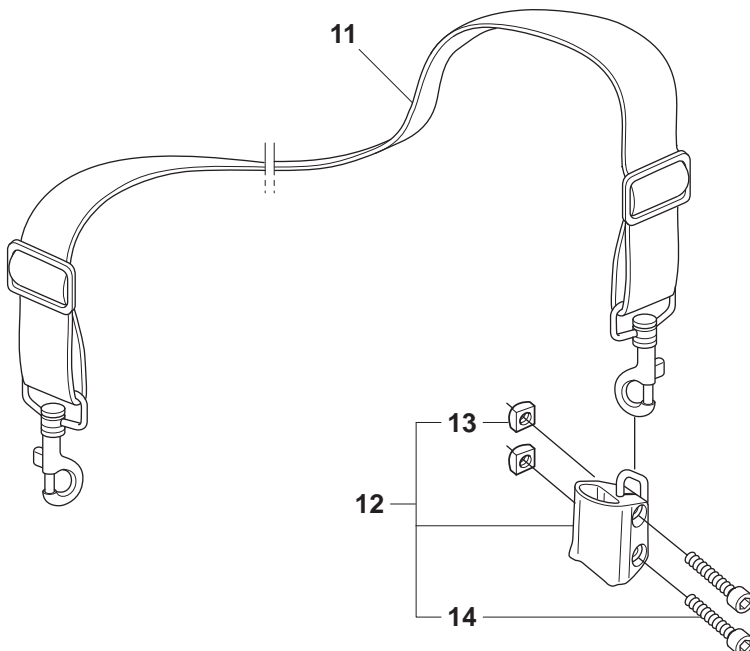

**Page Q**  
**K960**

<b>Pos.</b>	<b>Part No.</b>	<b>Description</b>	<b>Quantity</b>	<b>Notes</b>	<b>New Part</b>
1	503 14 29-02	WASHER	1		
2	506 29 75-02	STARTER HANDLE	1		
3	506 32 20-02	LABEL	1		
4	506 30 23-02	LABEL	1		
5	506 34 05-24	WHEEL GUARD ASSY	1	Rescue 14". Incl. 6 - 8	
5	506 34 05-28	WHEEL GUARD ASSY	1	Rescue 12". Incl. 6 - 8	
6	725 53 31-55	SCREW	1		
7	506 34 46-02	HANDLE	1		
8	506 26 63-02	LINING	2		
9	544 89 06-01	LABEL	1	14"	
9	544 89 06-03	LABEL	1	12"	
10	506 32 22-02	LABEL	1		
11	506 29 76-01	SHOULDER STRAP	1		
12	506 30 25-05	BRACKET	1	Incl. 13, 14	
13	503 22 65-04	NUT	2		
14	503 21 53-12	SCREW	2		

1

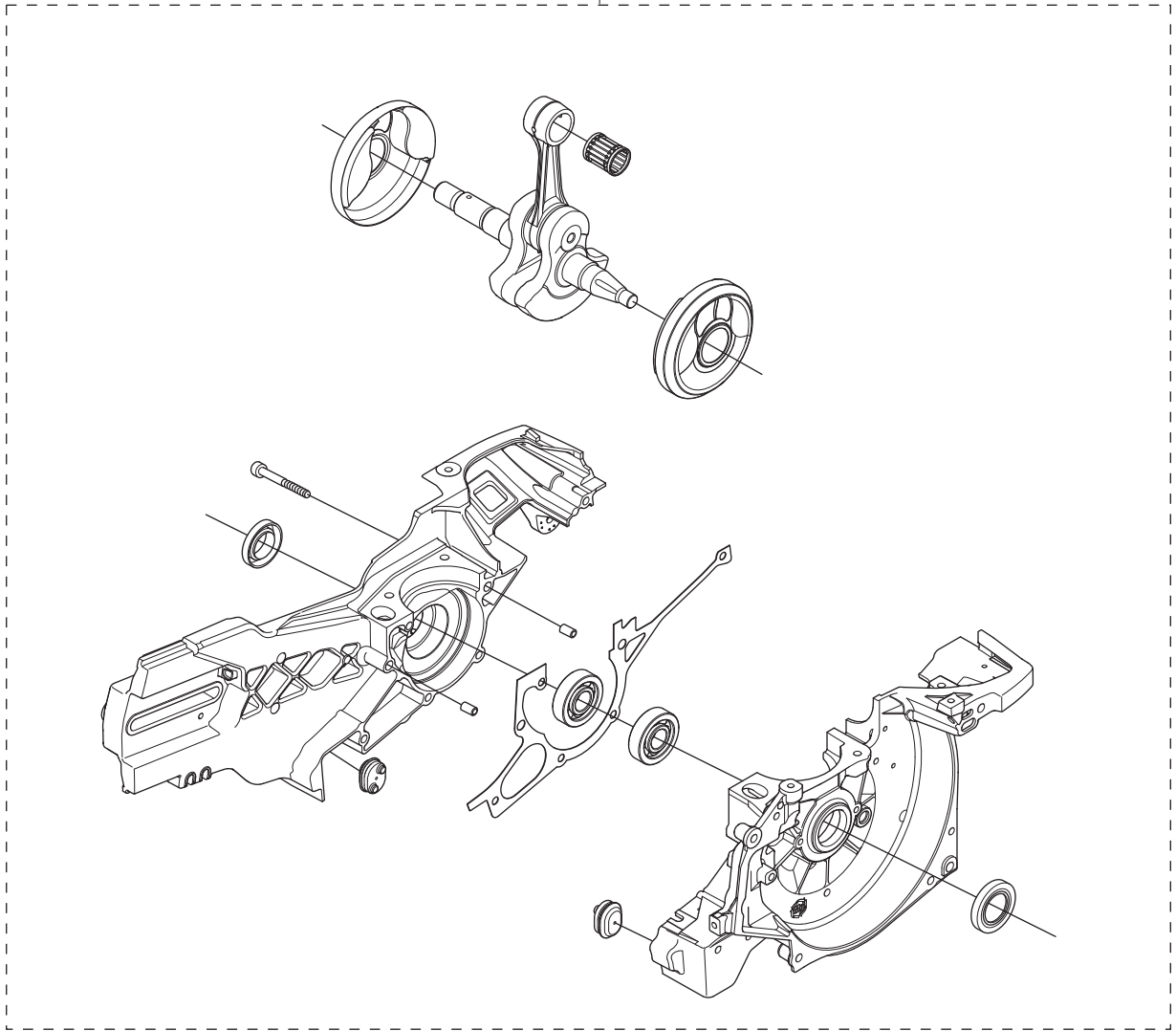



**Page R**  
**K960**

<b>Pos.</b>	<b>Part No.</b>	<b>Description</b>	<b>Quantity</b>	<b>Notes</b>	<b>New Part</b>
1	544 21 47-03	CRANKCASE CPL.	1		

1

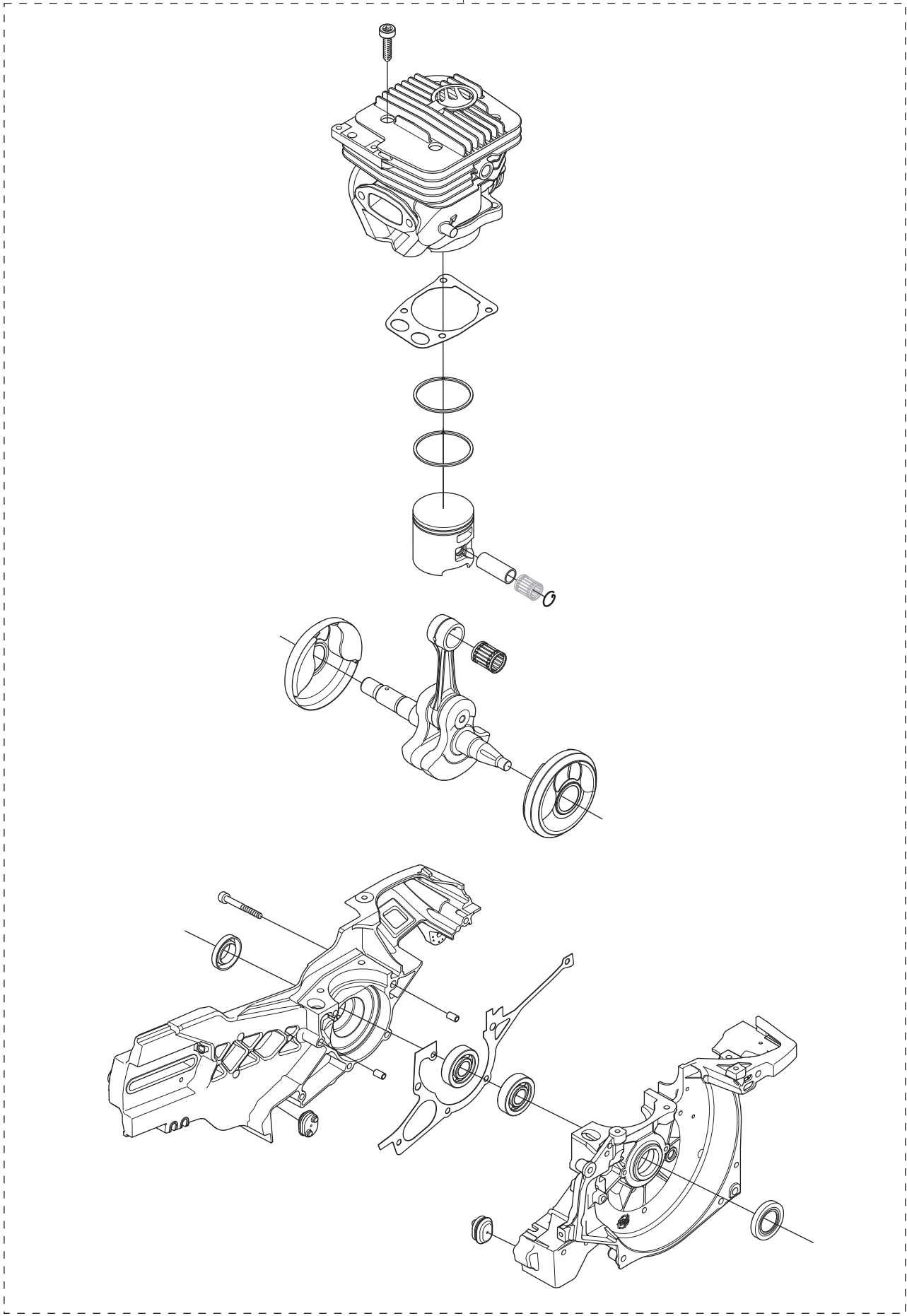

**Page S**  
**K960**

<b>Pos.</b>	<b>Part No.</b>	<b>Description</b>	<b>Quantity</b>	<b>Notes</b>	<b>New Part</b>
1	544 21 47-04	CRANKCASE CPL	1		