

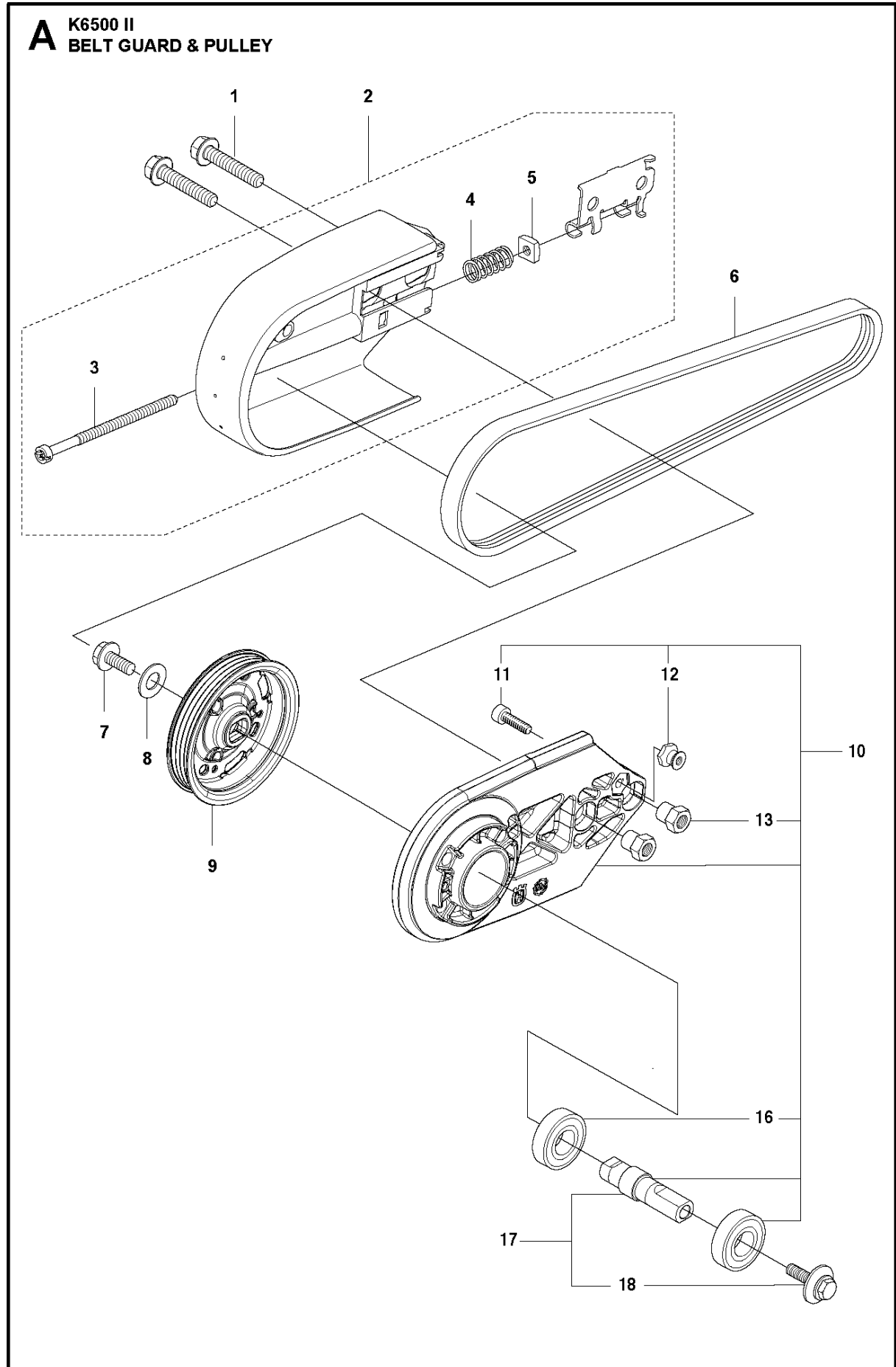

# SPARE PARTS LIST

POWER CUTTERS

K6500 II, 2016-06



## BELT GUARD &amp; PULLEY

K6500 II, 2016-06

Ref	Part No	Description	Remark	QTY	KIT
1	506 28 44-01	SCREW EHHFM		2	
2	506 39 36-02	BELT GUARD		1	
3	503 20 72-05	SCREW CITXSCM		1	
4	506 26 68-01	COMPRESSION SPRING		1	
5	506 40 93-01	NUT		1	
6	544 97 63-06	BELT		1	
7	503 20 00-45	SCREW EHHFM		1	
8	503 23 01-16	WASHER		1	
9	525 80 44-01	PULLEY		1	
10	589 39 03-01	BEARING HOUSING		1	
11	505 57 41-16	SCREW ITXSCM		1	10
12	586 41 69-01	STOP		1	10
13	584 78 81-01	NUT		2	10
16	583 95 33-01	BALL BEARING		2	10
17	588 13 84-01	SHAFT		1	
18	588 65 57-01	SCREW		1	17

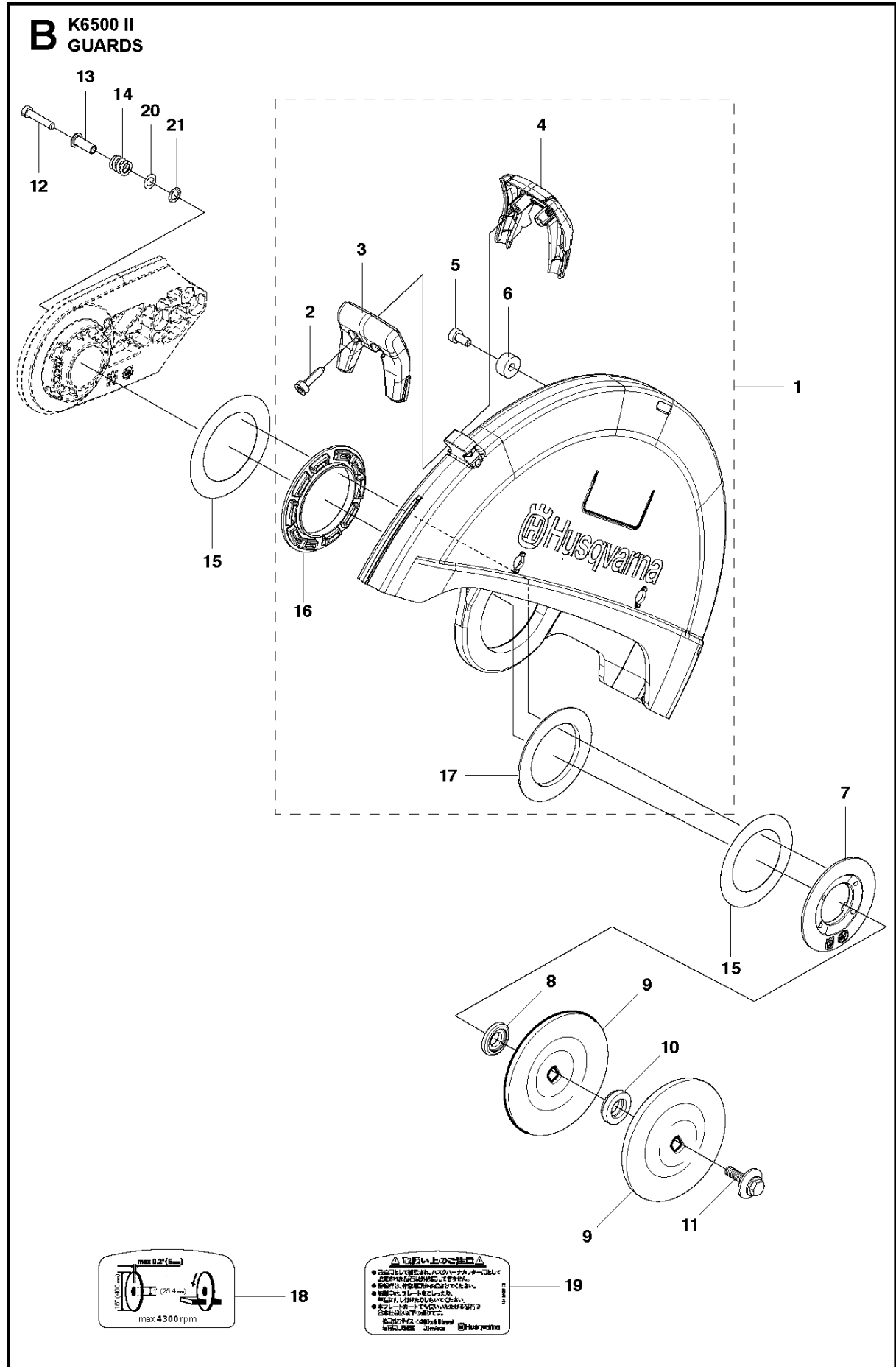

## GUARDS

K6500 II, 2016-06

Ref	Part No	Description	Remark	QTY KIT	
1	581 35 19-06	WHEEL GUARD	"16""	1	
2	504 90 94-14	SCREW ITXSCT		2	1
3	578 19 09-01	HANDLE HALF		1	1
4	578 76 09-01	HANDLE HALF		1	1
5	504 90 94-10	SCREW ITXSCT		1	1
6	581 62 03-01	STOP		1	1
7	584 43 77-01	DISC		1	
8	584 43 83-01	SUPPORT FLANGE		1	
9	583 87 44-02	FLANGE	Diam 105mm	1	
9	506 07 09-02	FLANGE WASHER	"Diam 119mm, Japan 14""/16""	1	
10	578 39 82-01	BUSHING	Diam 20/25,4mm	1	
10	581 60 54-03	BUSHING	Diam 30,5mm	1	
10	506 37 96-22	KIT	Diam 22,2mm	1	
11	588 65 57-01	SCREW		1	
12	544 21 84-30	SCREW ITXSCT		4	
13	584 43 82-02	SLEEVE	"16"", Black"	4	
14	584 43 81-01	SPRING		4	
15	584 43 78-01	SHIM		2	
16	584 43 79-01	LINING		1	1
17	584 43 80-01	LINING		1	1
18	581 11 77-07	DECAL	"16""	1	
19	584 99 26-03	DECAL	"16""	1	
20	582 23 31-01	WASHER		4	
21	582 23 32-01	WASHER		4	

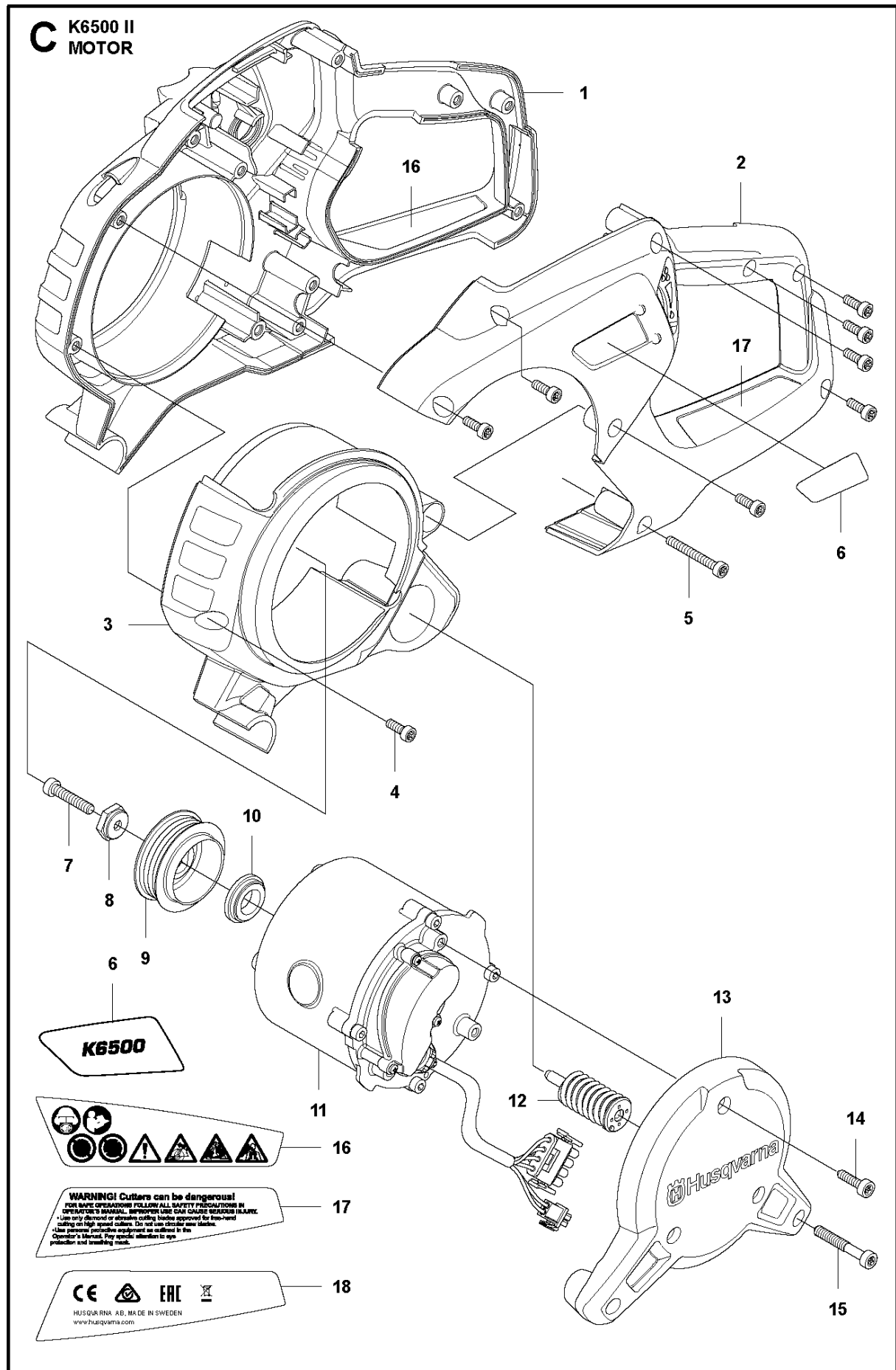

## MOTOR

K6500 II, 2016-06

Ref	Part No	Description	Remark	QTY KIT
1	574 84 49-02	HANDLE HALF		1
2	574 84 50-02	HANDLE HALF		1
3	529 27 95-02	MOTOR HOUSING		1
4	504 90 94-14	SCREW ITXSCT		8
5	504 90 94-40	SCREW ITXSCT		1
6	575 62 84-01	DECAL		1
7	544 21 84-30	SCREW ITXSCM		1
8	504 03 83-01	SPACING SLEEVE		1
9	580 88 25-01	DRIVING PULLEY		1
10	506 20 27-02	SUPPORT FLANGE		1
11	574 17 04-02	MOTOR		1
12	537 21 03-04	ANTIVIBRATION ELEMENT		1
13	529 29 12-01	MOTOR COVER		1
14	503 21 53-26	SCREW ITXSCM		3
15	544 21 84-40	SCREW ITXSCM		2
16	581 16 61-01	DECAL		1
17	581 16 60-01	DECAL		1
18	503 23 04-02	WASHER		3

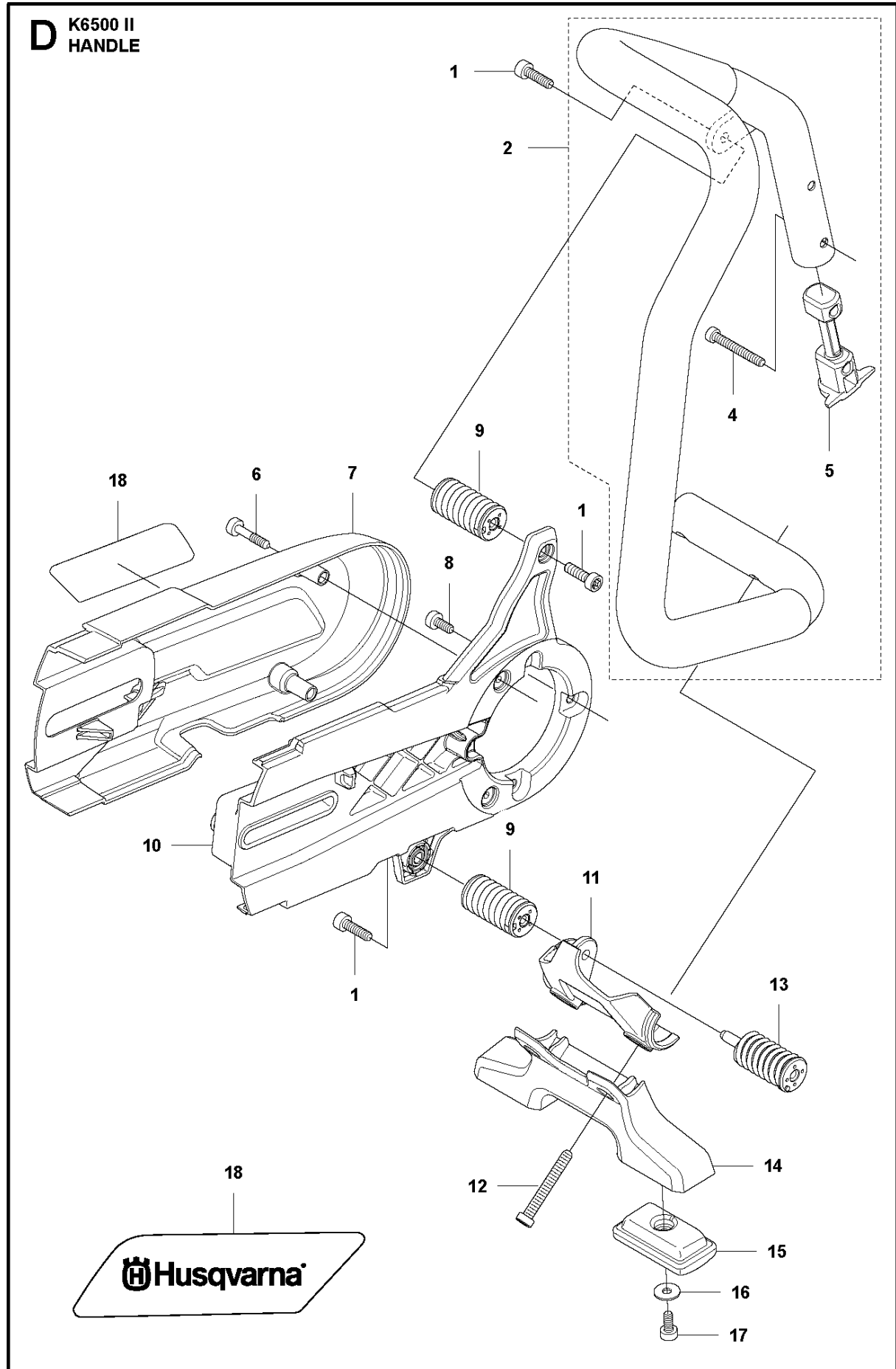



Ref	Part No	Description	Remark	QTY KIT
1	544 21 84-20	SCREW ITXSCM		3
2	581 80 26-01	FRONT HANDLE ASSY	Inkl. 3-5	1
4	504 90 94-40	SCREW ITXSCT		2
5	575 29 58-01	PLUG		1
6	503 21 53-26	SCREW ITXSCM		2
7	525 34 13-01	BELT GUARD		1
8	503 21 53-12	SCREW ITXSCM		4
9	575 41 22-01	ANTIVIBRATION ELEMENT		2
10	525 33 94-01	CHASSIS		1
11	586 42 61-01	BRACKET		1
12	503 21 54-45	SCREW ITXSCT		2
13	537 21 03-11	ANTIVIBRATION ELEMENT		1
14	575 55 03-01	GROUND SUPPORT		1
15	544 81 16-01	BASE		2
16	734 11 47-41	WASHER		2
17	503 21 53-12	SCREW ITXSCM		2
18	575 62 85-01	DECAL		1

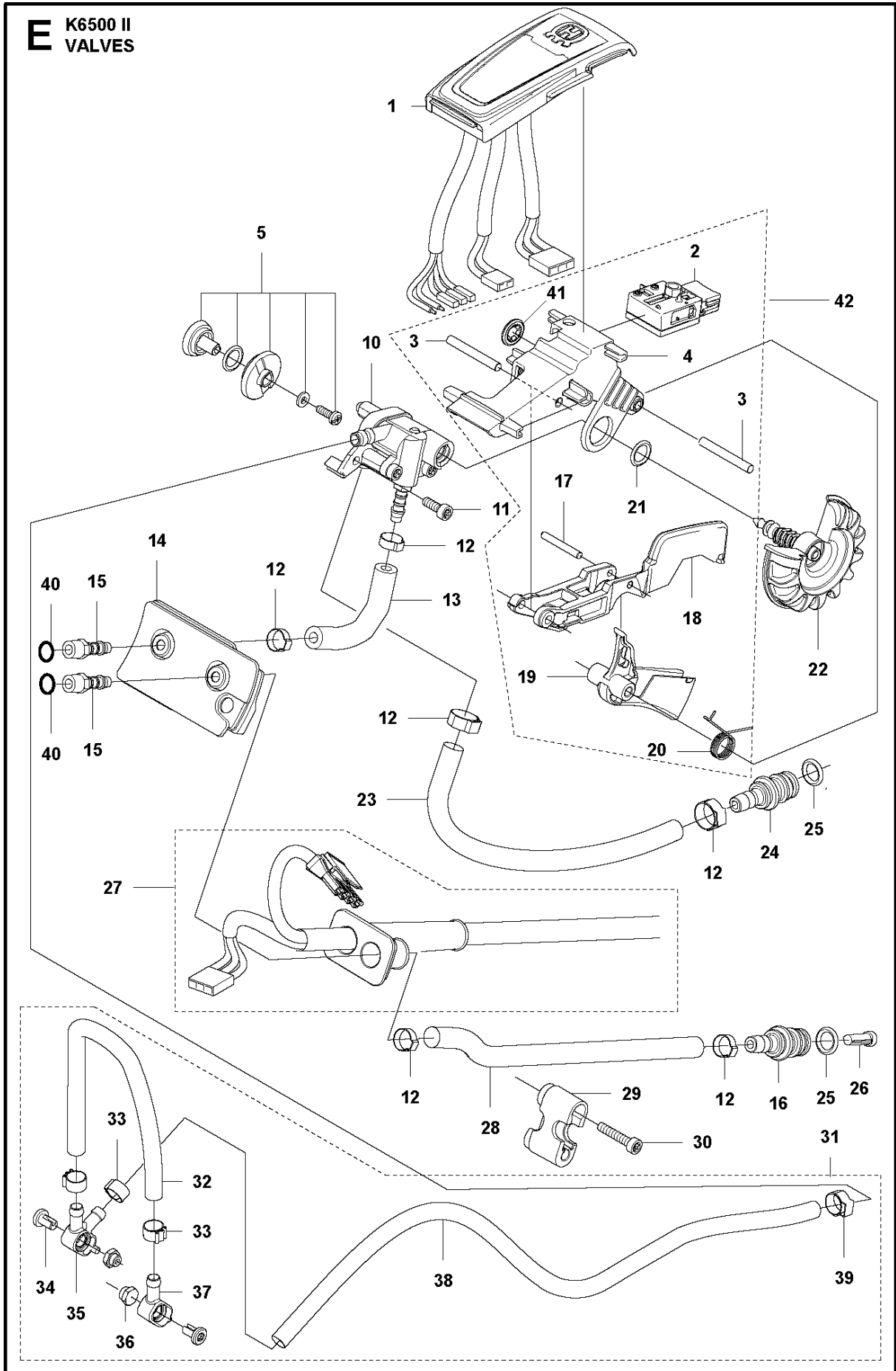

## VALVES

K6500 II, 2016-06

Ref	Part No	Description	Remark	QTY KIT
1	585 41 21-01	DISPLAY		1
2	589 79 77-01	TOGGLE SWITCH		1
3	720 13 18-06	PARALLEL PIN		2
4	524 42 90-01	CONSOLE		1
5	585 43 90-03	SPINDLE		1
10	522 96 02-03	VALVE		1
11	504 90 94-14	SCREW ITXSCT		1
12	576 12 97-01	HOSE CLAMP		6
13	580 66 81-02	HOSE		1
14	575 29 54-01	GROMMET		1
15	501 28 29-02	NIPPLE		2
16	582 17 54-01	NIPPLE		1
17	720 12 76-06	PARALLEL PIN		1
18	574 82 49-01	TRIGGER LOCKOUT		1
19	522 99 72-01	TRIGGER		1
20	574 35 42-02	TORSION SPRING		1
21	740 43 03-00	O-RING		1
22	525 52 20-01	VALVE SPINDLE		1
23	506 60 75-07	HOSE		1
24	506 28 91-03	NIPPLE		2
25	505 10 35-01	O-RING		2
26	506 29 88-01	FILTER		1
27	522 93 61-01	CABLE ASSY		1
28	506 60 75-02	HOSE		1
29	525 32 28-01	CLIP		1
30	504 90 94-25	SCREW ITXSCT		1
31	505 09 54-06	HOSE KIT	Incl. 32-38	1
32	506 60 68-03	HOSE		1
33	589 63 86-01	HOSE CLAMP		3
34	504 63 46-01	SCREW ITXSCT		2
35	587 38 89-01	HOUSING		1
36	576 79 84-02	NIPPLE		2
37	587 38 90-01	HOUSING		1
38	506 60 68-16	HOSE		1
39	506 49 87-01	HOSE CLAMP		1
40	740 42 06-00	O-RING		2
41	735 58 35-01	WASHER		1
42	588 57 61-02	TRIGGER		1

**F** K6500 II  
ACCESSORIES

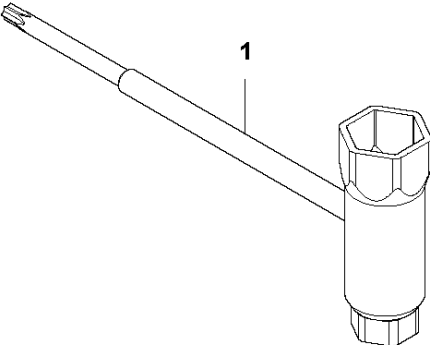

ACCESSORIES

K6500 II, 2016-06

Ref	Part No	Description	Remark	QTY KIT
1	506 38 26-01	TOOL	Torx 27	1