

# **TUFF TORQ**

## **TRANSAXLE**

### **PARTS LIST**

ISSUED 21.NOV. 1997.

K55HSQ0003

**MODEL**  
**K55J (HUSQ,US)**

## **INTRODUCTION**

Operating a profitable and efficient parts department should be the primary goal of every authorized KANZAKI. The purpose of this parts list is to provide all parties with consistent and clearly defined parts service.



**TUFF TORQ CORPORATION**

## HOW TO USE THIS PARTS LIST

This parts list indicates all of the component parts on the K55J transaxle and is made up of Illustration (refer to Attachment 1) and List (refer to Attachment 2).

On Attachment 2.

- ① shows the figure of Illustration.
- ② shows the function assembly name.
- ③ shows the function assembly code.

NOTE: FUNCTION ASSEMBLY is that we classify the transaxle into several assemblies by function and call it as function assembly.

This function assembly is composed of several parts, for example, see the function assembly code D92154-80540, this is composed of the parts shown on from 192154-24212 HOUSING to 192154-89210 BEARING 6202SH2. This function assembly is used for the informations on the engineering and design modification, but cannot be used for service.

- ④ shows the figure correspondent with Illustration. For example, Ref. No. 4-1, "4" shows Fig.4 and "1" shows the figure of part shown on Illustration.
  - ⑤ Level, Hereunder is given the relation among the number of dots(•), the level and the nominal parent-child relationship.
    - .....Parent parts
    - .....Child parts included in "•"
    - .....Child parts included in "••", Grand-child parts in terms of "•"
- For example, see Ref. No. 4-3, this is composed of from Ref. No. 4-4 to 4-7.

- ⑥ shows the part name.
- ⑦ shows the part code number.
- ⑧ shows the total quantity of part used in one unit.
- ⑨ Service, the part which "NO" is indicated cannot be provided for service in point of quantity and structure.

Attachment 1

②  
① → Fig.4 MOTOR SHAFT ASSY

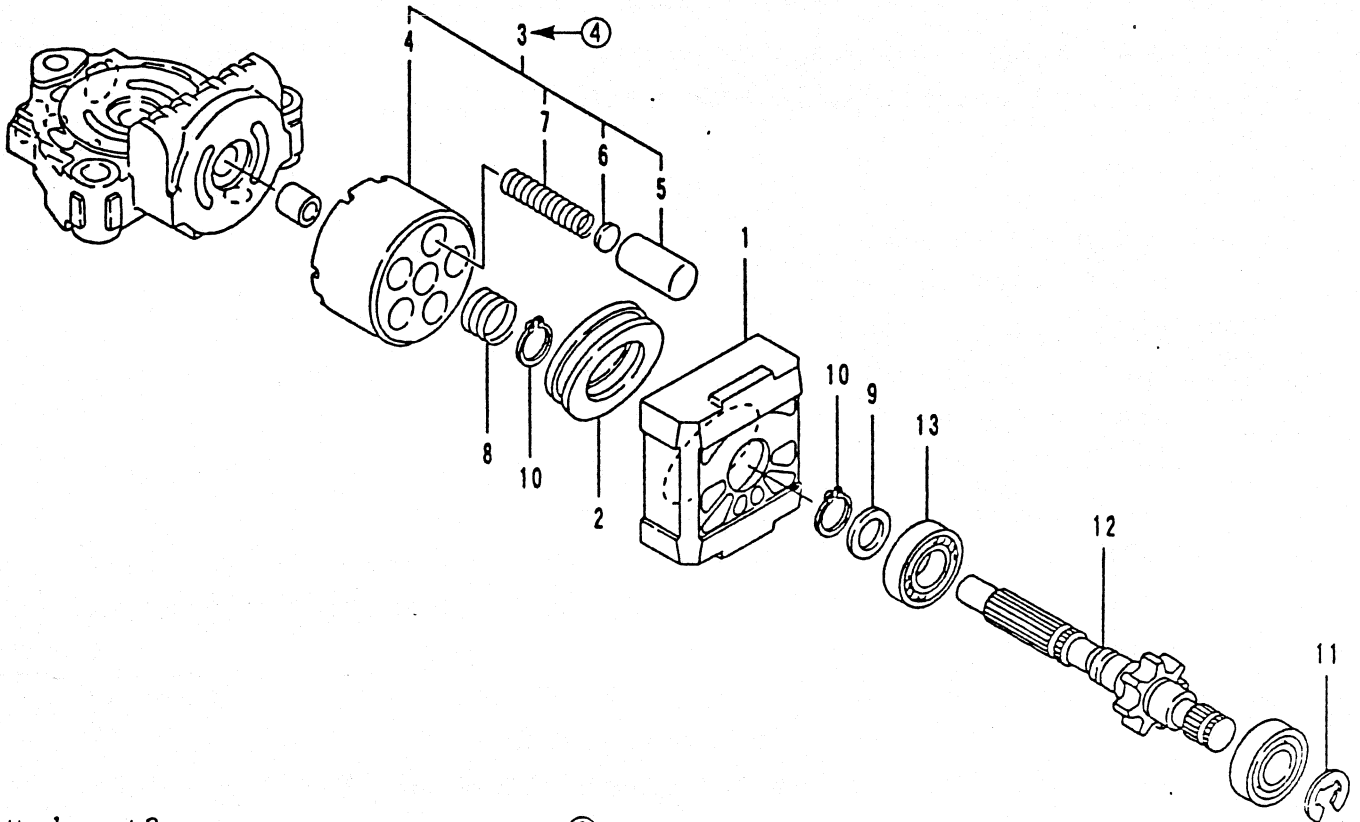

Attachment 2

②  
① → Fig.4 MOTOR SHAFT ASSY

③  
( D92154-80540 )

Ref. No.	Level	Description	Part No.	Q'ty/Unit			Service	Remarks
				K65				
4 - 1	.	HOUSING	192154-24212	1				
4 - 2	.	BEARING (THRUST)	192154-24240	1				
4 - 3	.	CYLINDER BLOCK CMP	192154-25140	1				
4 - 4	..	CYLINDER BLOCK	192154-25120	1		NO		
4 - 5	..	PISTON	192154-25150	5		NO		
4 - 6	..	WASHER 11	192154-25170	5		NO		
4 - 7	..	SPRING (PISTON)	192154-25190	5		NO		
4 - 8	.	SPRING	192154-25200	1				
4 - 9	.	WASHER 15×20×1	192154-25210	1				
4 - 10	.	RING 15	192154-25310	2				
4 - 11	.	RING E 15	192154-85310	1				
4 - 12	.	SHAFT(MOTOR)	192154-89200	1				
4 - 13	.	BEARING 6202SH2	192154-89210	1				

# CONTENTS

		Page
Fig. 0	TRANSAXLE KIT ASSY .....	1
Fig. 1	TRANSAXLE CASE ASSY .....	3
Fig. 2	CENTER CASE ASSY .....	5
Fig. 3	PUMP SHAFT ASSY .....	7
Fig. 4	MOTOR SHAFT ASSY .....	9
Fig. 5	RANGE SHIFT ASSY .....	11
Fig. 6	CONTROL SHAFT ASSY .....	13
Fig. 7	DIFF. GEAR ASSY .....	15
Fig. 8	AXLE SHAFT ASSY .....	17
Fig. 9	BRAKE ASSY .....	19
Fig. 10	LABEL ASSY .....	21

Fig.0 TRANSAXLE KIT ASSY

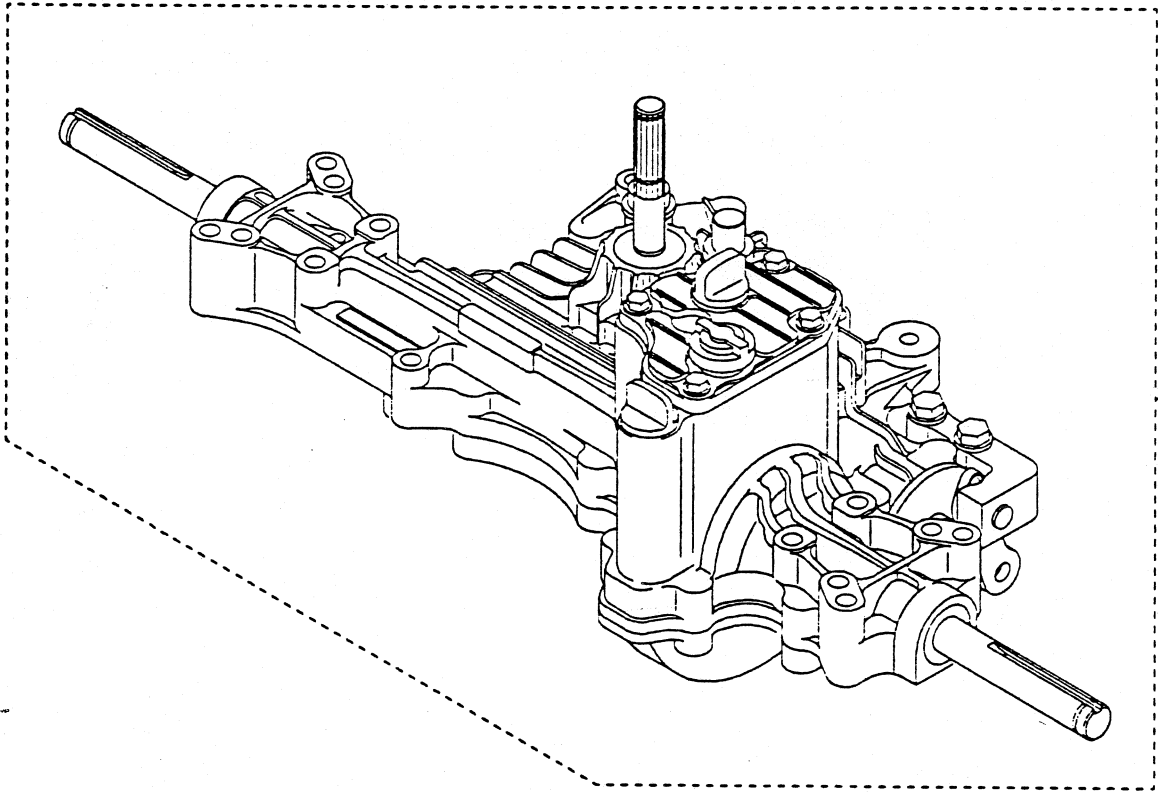
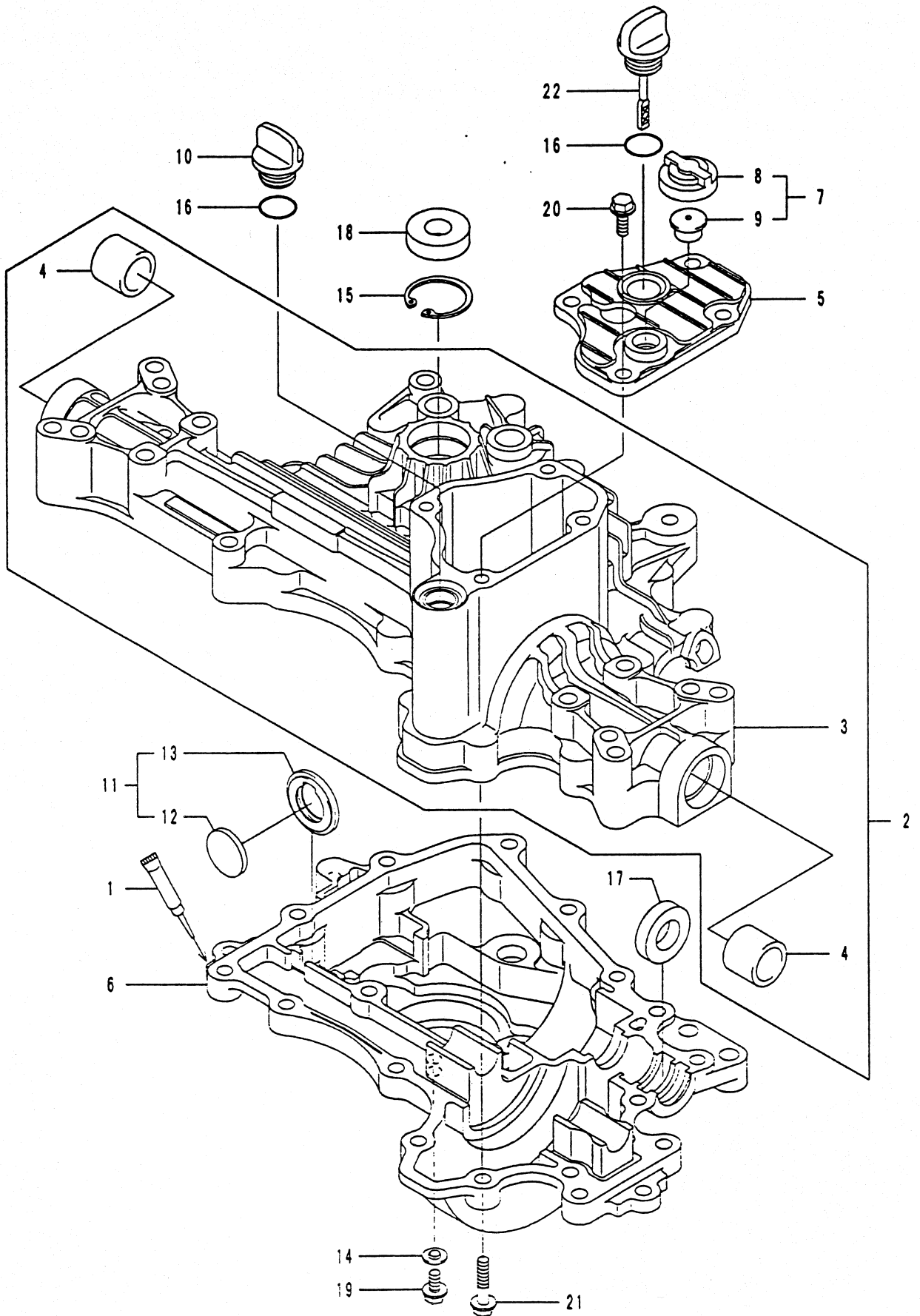



Fig.1 TRANSAXLE CASE ASSY





## Fig.1 TRANSAXLE CASE ASSY

( D92163-80180 )

Ref. No.	Level	Description	Part No.	Q'ty/Unit		Service	Remarks
				K55J			
1-1	.	SEALANT	194855-24020	1		NO	
1-2	.	UPPER CASE CMP.	192163-84250				
1-3	..	UPPER CASE	192163-84260	1		NO	
1-4	..	BUSHING 19.05	192163-34240	2		NO	
1-5	.	TOP COVER	192163-84130	1			
1-6	.	LOWER CASE	192163-24270	1			
1-7	.	VENT VALVE 15	194859-24252	1			
1-8	..	CAP, VENT VALVE	194859-24262	1		NO	
1-9	..	BODY, VENT VALVE	194859-24270	1		NO	
1-10	.	CAP, OIL 20	194855-24290	1			
1-11	.	MAGNET CMP.	192163-24350	1			
1-12	..	MAGNET 28×3.5	192163-24360	1		NO	
1-13	..	COVER (MAGNET	192163-24370	1		NO	
1-14	.	WASHER, SEAL 8	22190-080000	1			
1-15	.	RING 35	22252-000350	1			
1-16	.	PACKING P 18	24311-000180	2			
1-17	.	SEAL TC123207	24421-123207	1			
1-18	.	SEAL TC153507	24421-153507	1			
1-19	.	BOLT 8×12	26106-080122	1			
1-20	.	BOLT 8×20	26106-080202	4			
1-21	.	TAPPING, SCREW 8×30	26476-080302	17			
1-22	.	CAP 20×49	192163-84140	1			

Fig.2 CENTER CASE ASSY

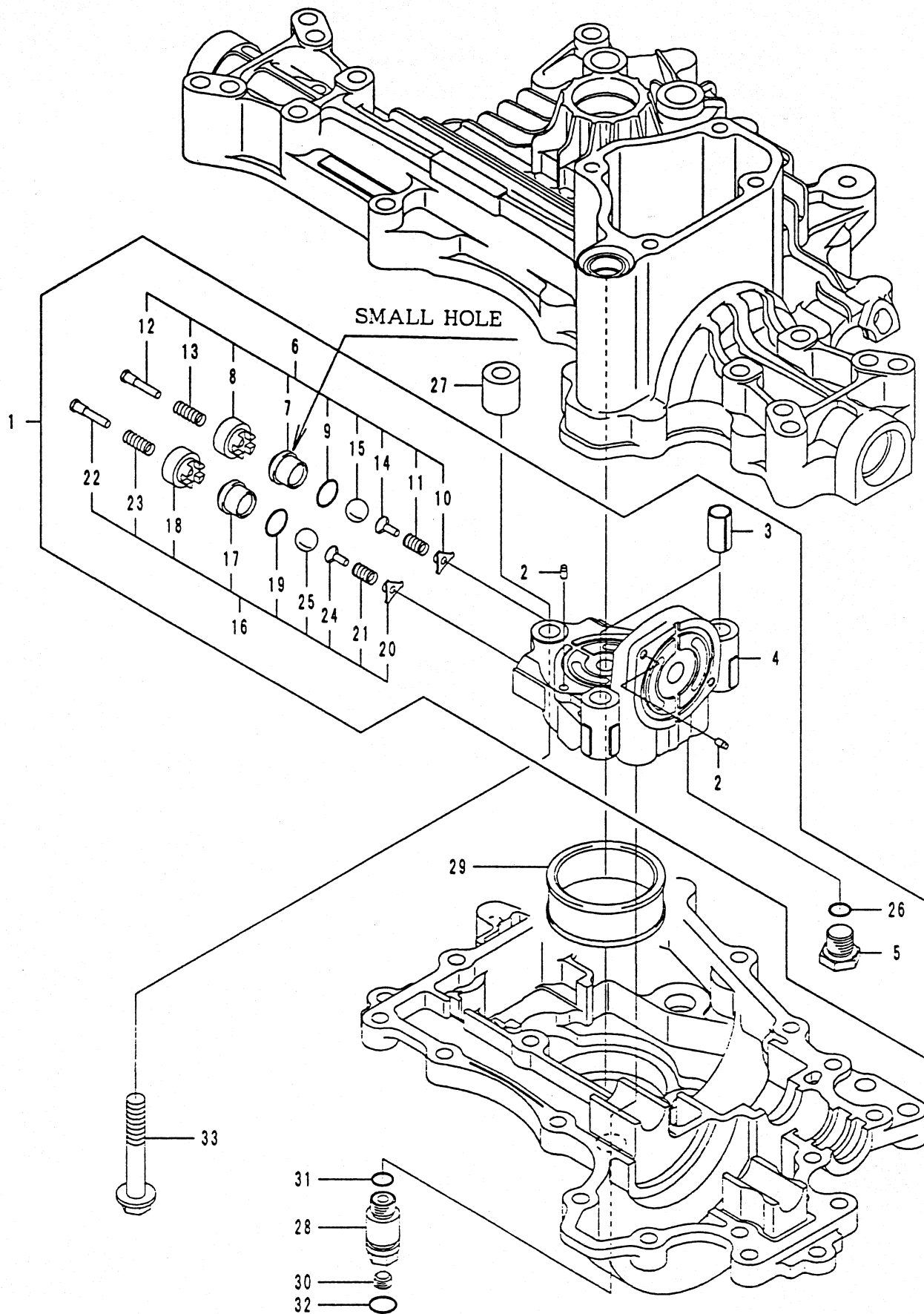

Ref. No.	Level	Description	Part No.	Qty/Unit		Service	Remarks
				K55J			
2-1	.	CENTER CASE CMP.	192163-24500	1			
2-2	..	KNOCK PIN 3.5	192163-24420	4			
2-3	..	KNOCK PIN 12X22	192154-24450	2			
2-4	..	CENTER CASE	192163-24510	1		NO	
2-5	..	PLUG PF1/4	192154-24550	1			
2-6	..	VALVE(A-1 SET	192163-24610	1			
2-7	...	SLEEVE(A1	192163-24641	1		NO	
2-8	...	VALVE(B	192154-24660	1		NO	
2-9	...	PACKING 1015	192154-24670	1			
2-10	...	HOLDER(BYPASS	192154-24690	1		NO	
2-11	...	SPRING	192154-24701	1		NO	
2-12	...	PUSH PIN	192154-24710	1		NO	
2-13	...	SPRING PUSH PIN	192163-24720	1		NO	
2-14	...	HOLDER(BALL	192154-24730	1		NO	
2-15	...	BALL 3/8	24190-120001	1		NO	
2-16	..	VALVE(A-2 SET	192163-24620	1			
2-17	...	SLEEVE(A2	192163-24650	1		NO	
2-18	...	VALVE(B	192154-24660	1		NO	
2-19	...	PACKING 1015	192154-24670	1			
2-20	...	HOLDER(BYPASS	192154-24690	1		NO	
2-21	...	SPRING	192154-24701	1		NO	
2-22	...	PUSH PIN	192154-24710	1		NO	
2-23	...	SPRING PUSH PIN	192163-24720	1		NO	
2-24	...	HOLDER (BALL	192154-24730	1		NO	
2-25	...	BALL 3/8	24190-120001	1		NO	
2-26	..	PACKING P 11	24311-000110	1			
2-27	.	COLLAR 10X20X20	192163-24760	1			
2-28	.	CONNECTER	192163-24900	1			
2-29	.	FILTER	192163-24960	1			
2-30	.	PLUG PT1/8	23871-010000	1			
2-31	.	PACKING P 11	24311-000110	1			
2-32	.	PACKING P 14	24311-000140	1			
2-33	.	BOLT 10X60	26106-100602	3			

Fig.3 PUMP SHAFT ASSY

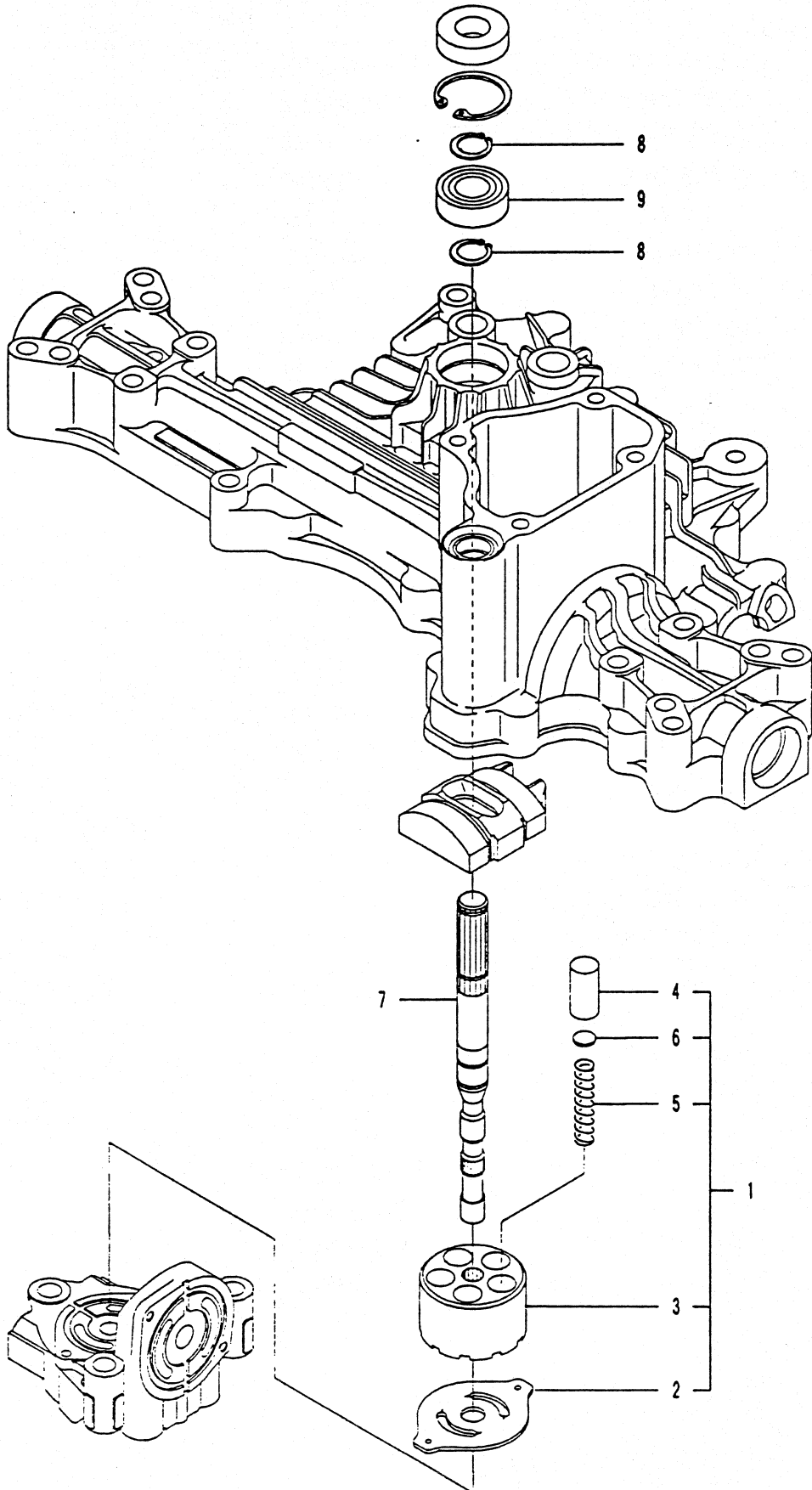



Fig.4 MOTOR SHAFT ASSY

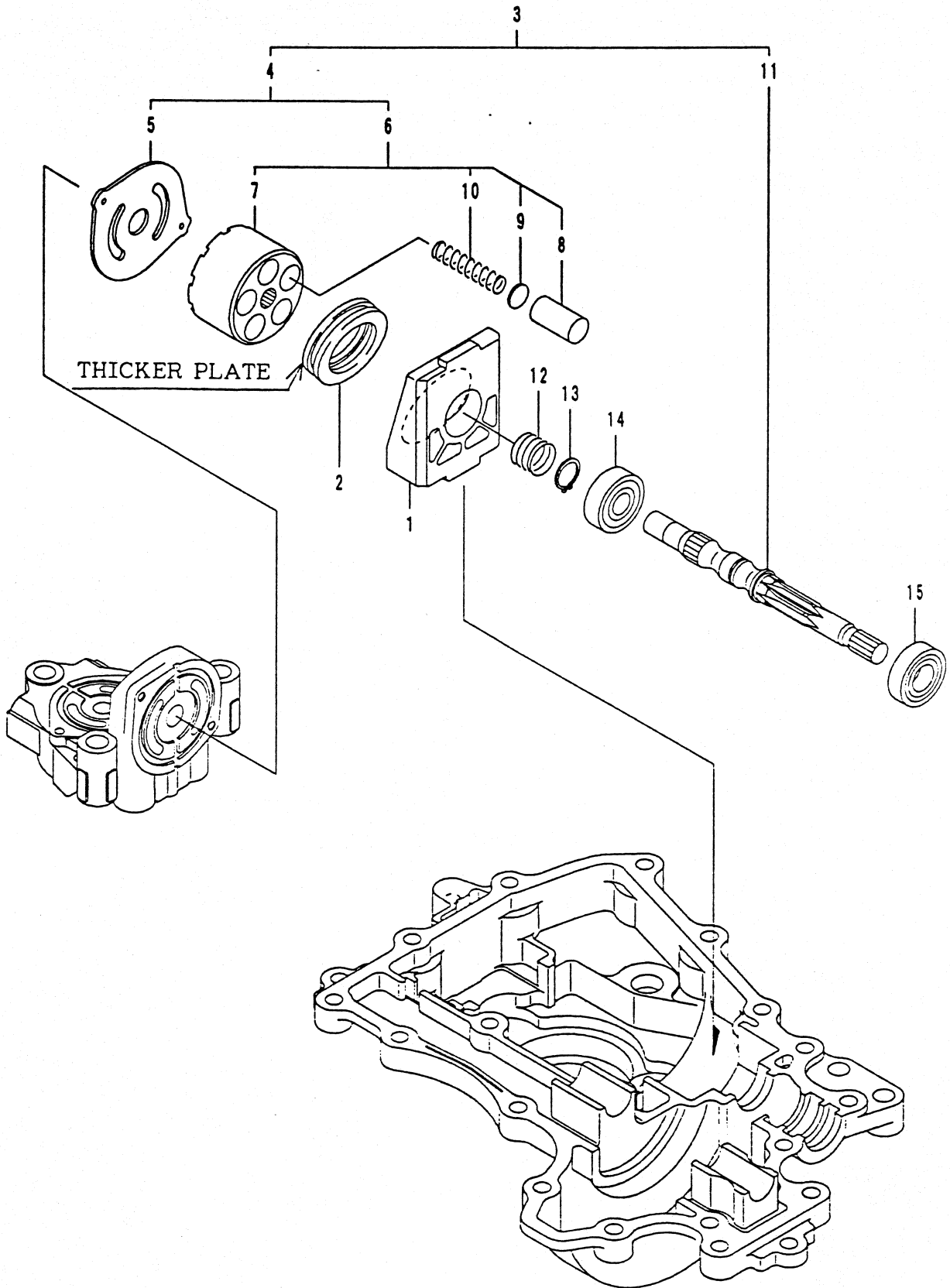
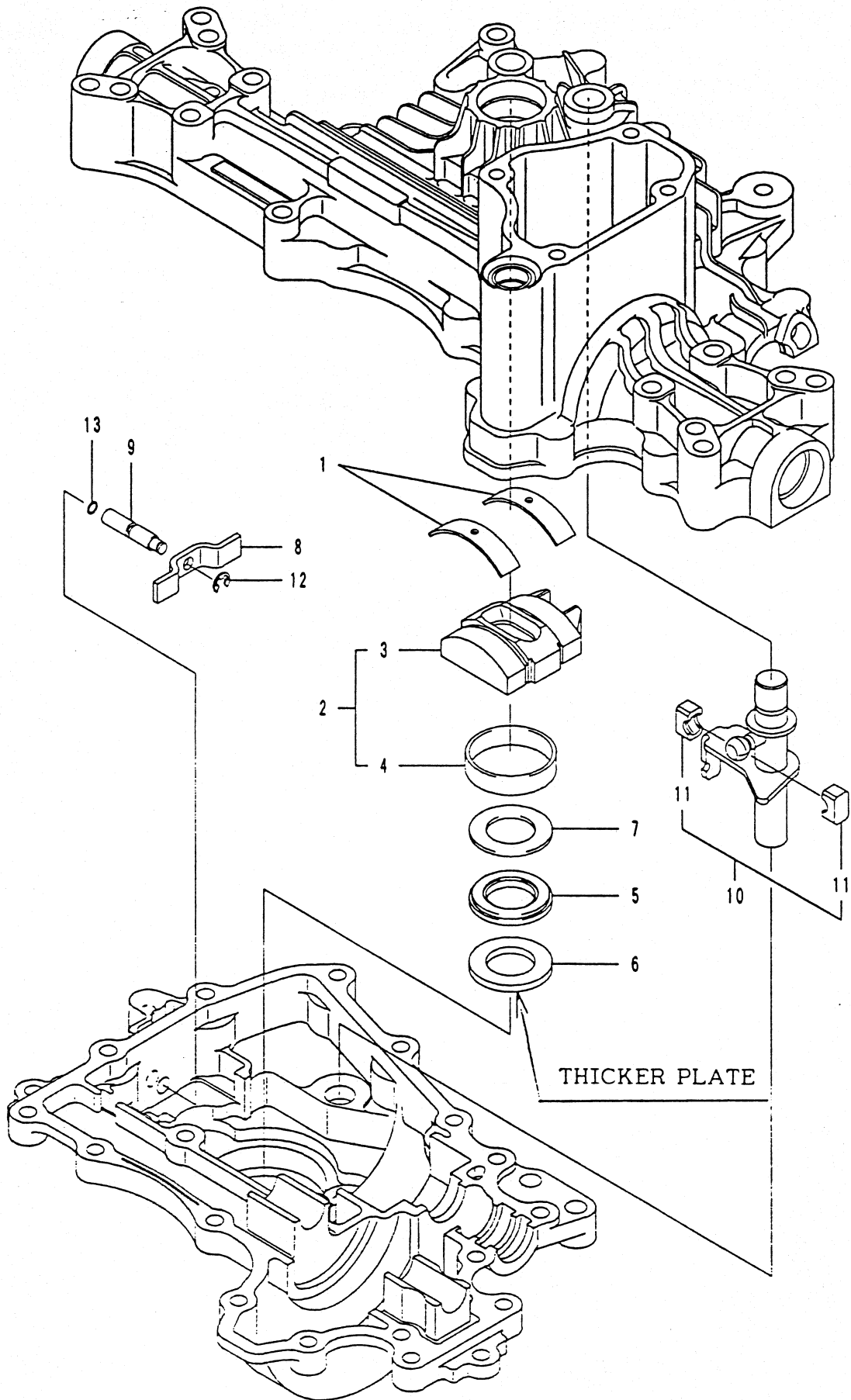

Fig.4 MOTOR SHAFT ASSY

( D92163-25210 )

Ref. No.	Level	Description	Part No.	Q'ty/Unit		Service	Remarks
				K55J			
4-1	.	HOUSING	192163-24210	1			
4-2	.	BEARING 51106	192163-24240	1			
4-3	.	MOTOR SHAFT SET	192163-25050	1			
4-4	..	CYLINDER BLOCK M COMP.	192163-25211	1			
4-5	...	PLATE(MOTOR	192163-24411	1		NO	
4-6	...	CYLINDER BLOCK COMP.SET	192168-25210	1		NO	
4-7	....	CYLINDER BLOCK	192168-25120	1		NO	
4-8	....	PISTON	192154-25150	5		NO	
4-9	....	WASHER 11	192154-25170	5		NO	
4-10	....	SPRING(PISTON	192154-25190	5		NO	
4-11	..	MOTOR SHAFT	192163-25291	1			
4-12	.	SPRING	192154-25200	1			
4-13	.	RING 15	192154-25310	1			
4-14	.	BALL BEARING 6002	24101-060024	1			
4-15	.	BALL BEARING 6201	24101-062014	1			

Fig.5 RANGE SHIFT ASSY





# Fig.5 RANGE SHIFT ASSY

( D92163-27100 )

Ref. No.	Level	Description	Part No.	Q'ty/Unit		Service	Remarks
				K55J			
5-1	.	THRUST METAL	192163-27051	2			
5-2	.	SWASH PLATE CMP.	192163-27100	1			
5-3	..	SWASH PLATE	192163-27120	1		NO	
5-4	..	BUSHING(PUMP	192163-27150	1		NO	
5-5	.	BEARING K81105	192163-27160	1			
5-6	.	THRUST PLATE(A	192163-27170	1			
5-7	.	THRUST PLATE(B	192163-27180	1			
5-8	.	C ARM(BYPASS	192163-27250	1			
5-9	.	PUSH PIN	192163-27262	1			
5-10	.	BLOCK SET	192154-27321	1			
5-11	..	BLOCK(SHIFT	192154-27301	2		NO	
5-12	.	RING 5	22272-000050	1			
5-13	.	PACKING P 5	24311-000050	1			

Fig.6 CONTROL SHAFT ASSY

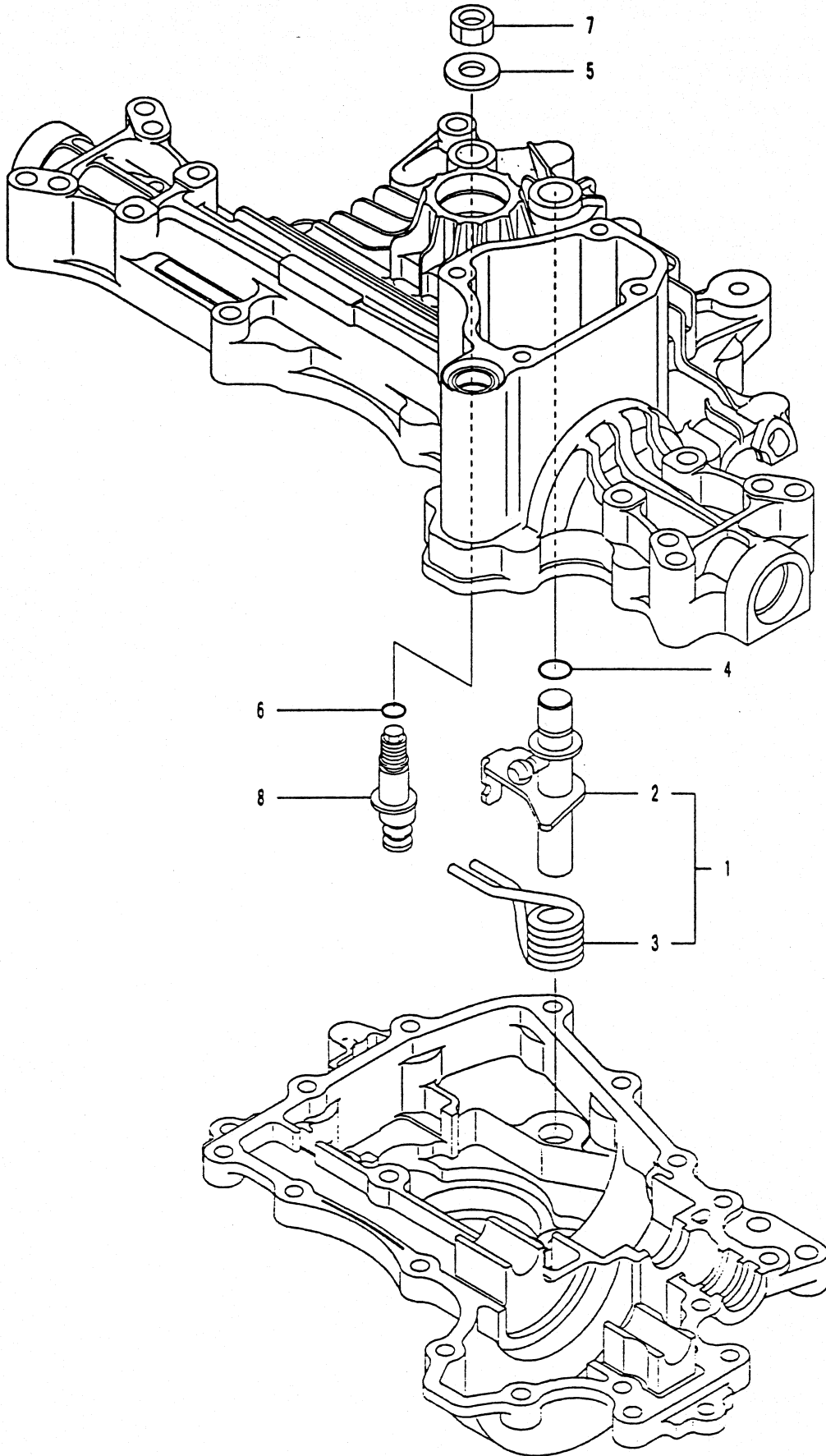



Fig.7 DIFF. GEAR ASSY

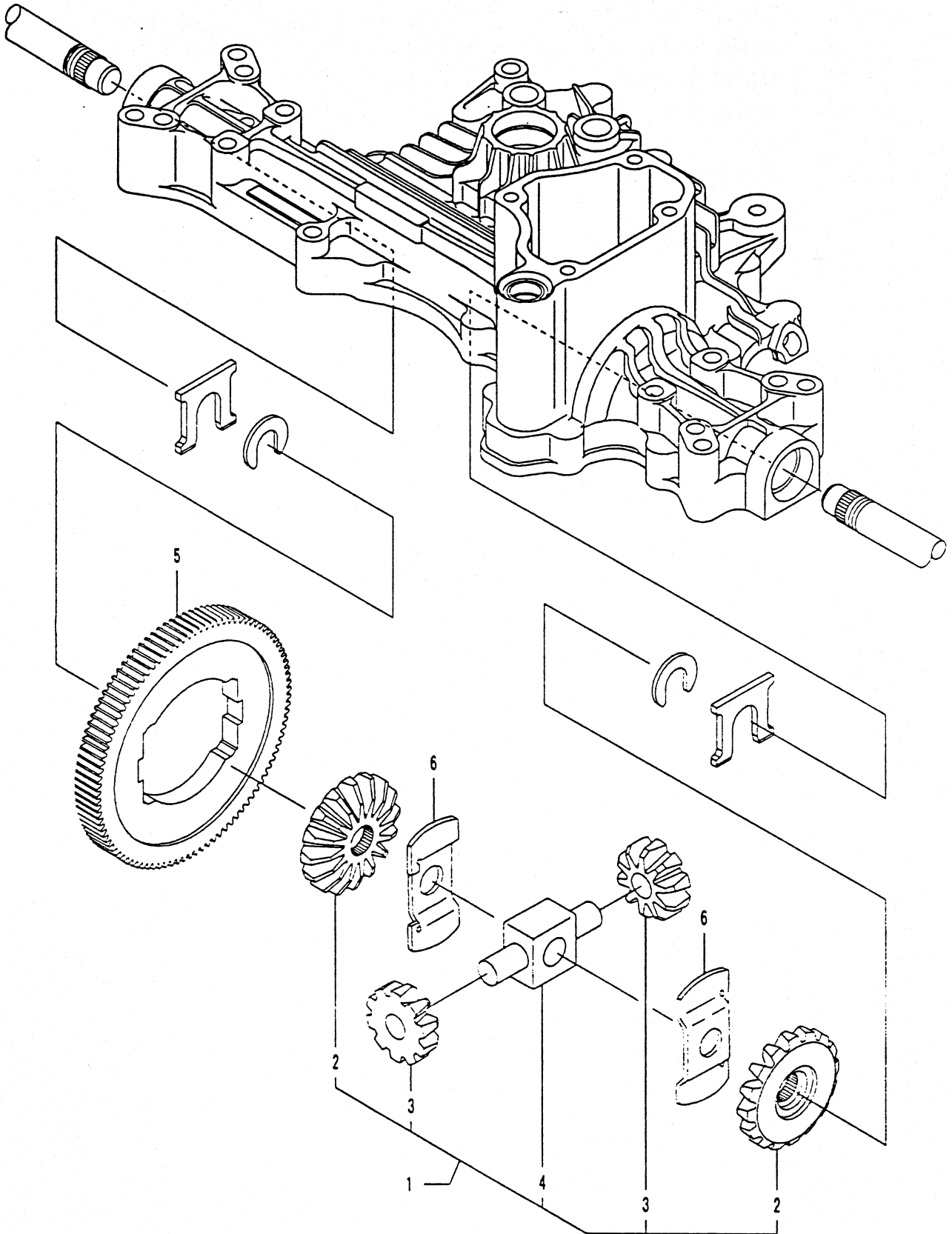



Fig.8 AXLE SHAFT ASSY

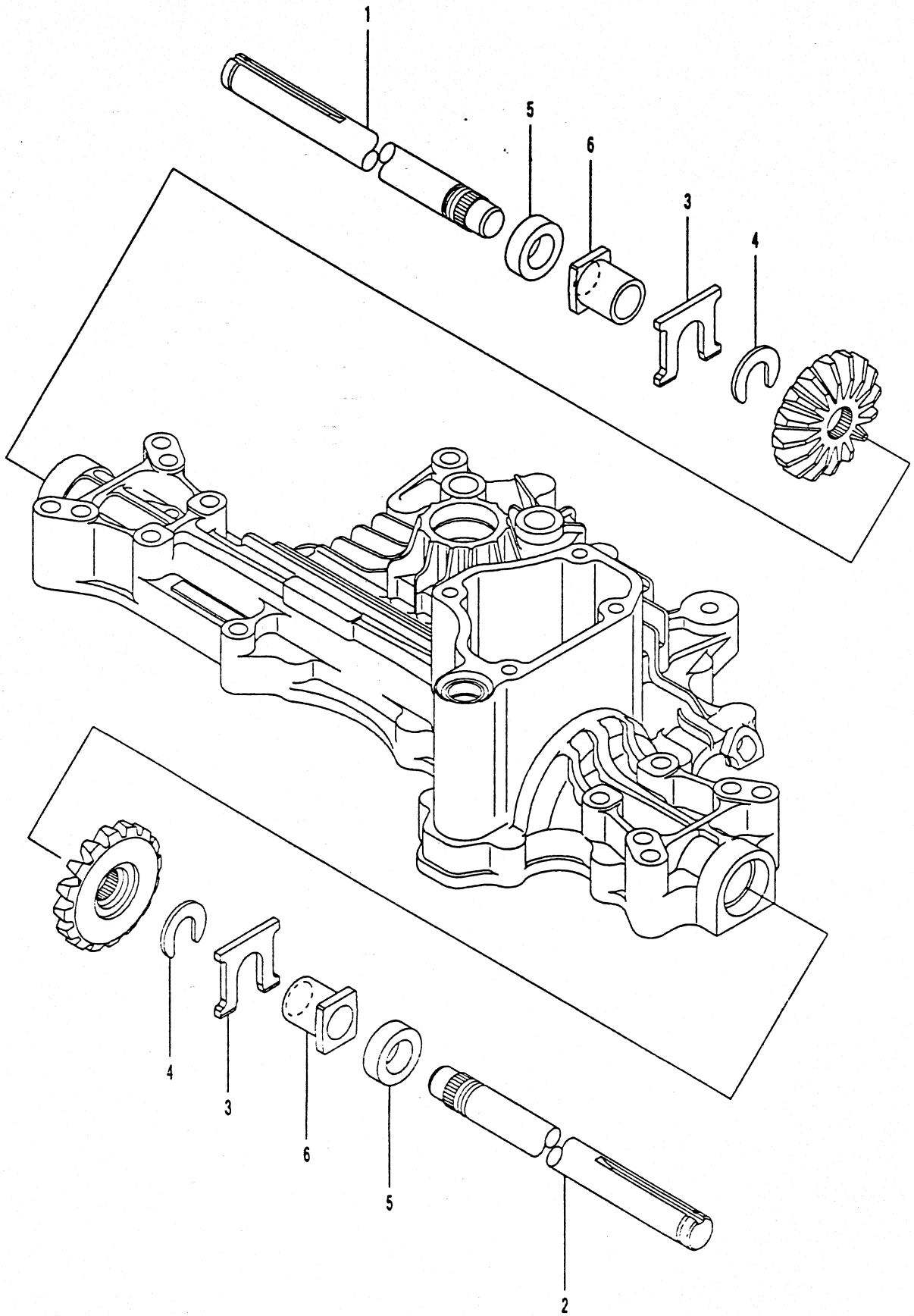

Fig.8 AXLE SHAFT ASSY

( D92163-34110 )

Ref. No.	Level	Description	Part No.	Q'ty/Unit		Service	Remarks
				K55J			
8 - 1	.	AXLE SHAFT L	192163-34130	1			
8 - 2	.	AXLE SHAFT R	192163-34140	1			
8 - 3	.	THRUST WASHER	192163-34261	2			
8 - 4	.	RING 16	192163-34270	2			
8 - 5	.	SEAL(S 19X32X8	192163-34280	2			
8 - 6	.	BUSHING 19X25	192163-34350	2			

Fig.9 BRAKE ASSY

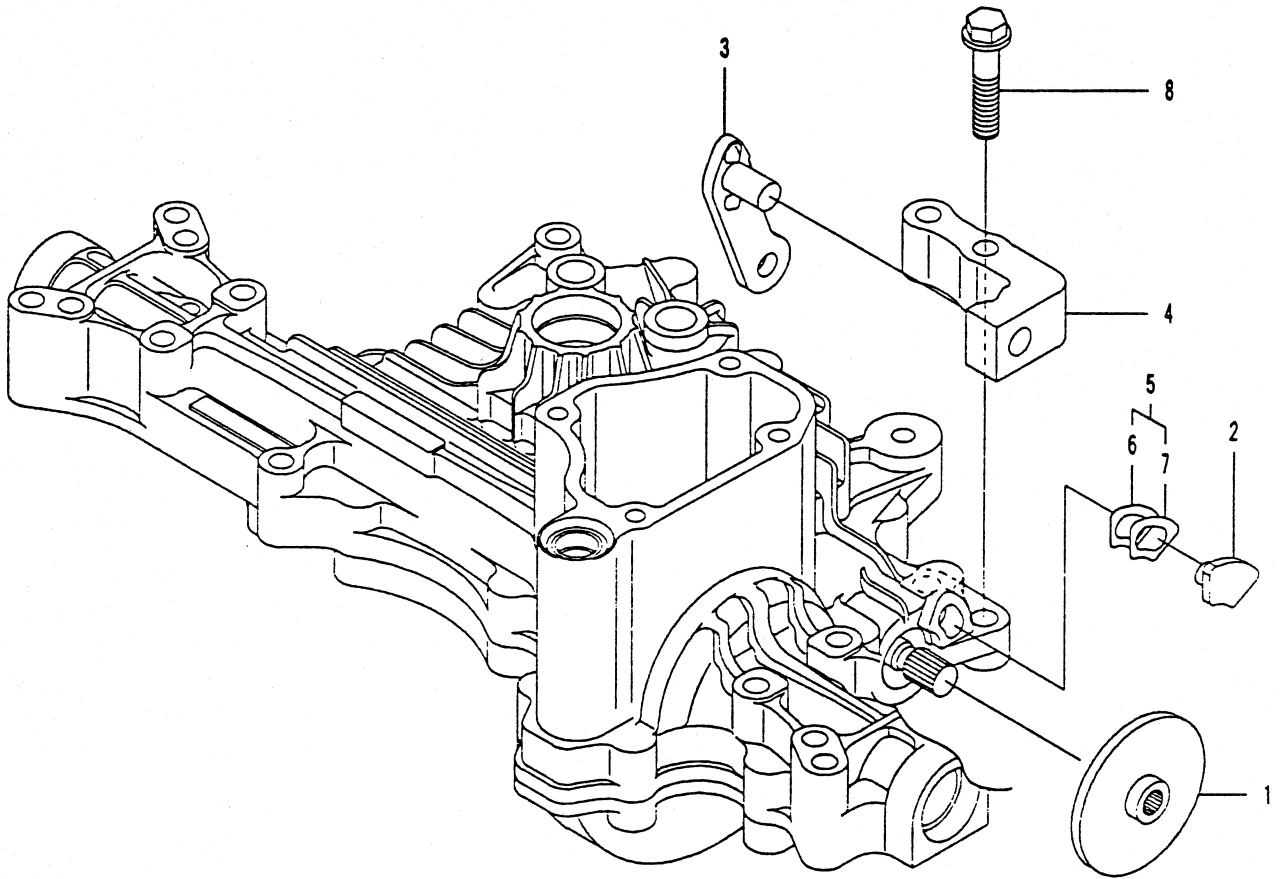





Fig.10 LABEL ASSY

1

MANUFACTURED UNDER US PAT.

#5473964



## **PARTS INDEX**

All parts of this Parts List is arranged by Part No. order (depending on the spot where the part is used). If you want to know by Part No. where your object part is used, please use this Part List.

# PARTS INDEX

Part No.	Description	Ref.No.	Page	Part No.	Description	Ref.No.	Page
192154-24450	KNOCK PIN 12×22	2- 3	5	192163-25170	WASHER 9.4	3- 6	7
192154-24550	PLUG PF1/4	2- 5	5	192163-25211	CYLINDER BLOCK M COMP.	4- 4	9
192154-24660	VALVE(B	2- 8	5	192163-25240	SHAFT, PUMP	3- 7	7
		2-18	5	192163-25291	MOTOR SHAFT	4-11	9
192154-24670	PACKING 1015	2- 9	5	192163-27051	THRUST METAL	5- 1	11
		2-19	5	192163-27100	SWASH PLATE CMP.	5- 2	11
192154-24690	HOLDER(BYPASS	2-10	5	192163-27120	SWASH PLATE	5- 3	11
		2-20	5	192163-27150	BUSHING(PUMP	5- 4	11
192154-24701	SPRING	2-11	5	192163-27160	BEARING K81105	5- 5	11
		2-21	5	192163-27170	THRUST PLATE(A	5- 6	11
192154-24710	PUSH PIN	2-12	5	192163-27180	THRUST PLATE(B	5- 7	11
		2-22	5	192163-27250	C ARM(BYPASS	5- 8	11
192154-24730	HOLDER(BALL	2-14	5	192163-27262	PUSH PIN	5- 9	11
		2-24	5	192163-29720	SP(TORSION 630	6- 3	13
192154-25150	PISTON	4- 8	9	192163-31550	DIFF. SIDE GEAR	7- 2	15
192154-25170	WASHER 11	4- 9	9	192163-31650	DIFF. PINION	7- 3	15
192154-25190	SPRING(PISTON	4-10	9	192163-33511	FINAL GEAR	7- 5	15
192154-25200	SPRING	4-12	9	192163-34130	AXLE SHAFT L	8- 1	17
192154-25310	RING 15	3- 8	7	192163-34140	AXLE SHAFT R	8- 2	17
		4-13	9	192163-34240	BUSHING 19.05	1- 4	3
192154-27301	BLOCK(SHIFT	5-11	11	192163-34261	THRUST WASHER	8- 3	17
192154-27321	BLOCK SET	5-10	11	192163-34270	RING 16	8- 4	17
192154-29702	FULCRUM(ECCENTRICITY	6- 8	13	192163-34280	SEAL(S 19×32×8	8- 5	17
192154-31530	THRUST WASHER(DIFF.	7- 6	15	192163-34350	BUSHING 19×25	8- 6	17
192154-31810	SHAFT(DIFF. PINION	7- 4	15	192163-36110	DISK(BRAKE	9- 1	19
192163-24210	HOUSING	4- 1	9	192163-36120	SHOE(BRAKE	9- 2	19
192163-24240	BEARING 51106	4- 2	9	192163-36130	SHIM 0.3(BRAKE	9- 6	19
192163-24270	LOWER CASE	1- 6	3	192163-36150	SHIM 0.5(BRAKE	9- 7	19
192163-24350	MAGNET CMP.	1-11	3	192163-36160	STAY(BRK. LEVER	9- 4	19
192163-24360	MAGNET 28×3.5	1-12	3	192163-36170	SHIM SET	9- 5	19
192163-24370	COVER(MAGNET	1-13	3	192163-36180	BOLT 10×45	9- 8	19
192163-24401	PLATE(PUMP	3- 2	7	192163-65311	LABEL 964	10- 1	21
192163-24411	PLATE(MOTOR	4- 5	9	192163-84130	TOP COVER	1- 5	3
192163-24420	KNOCK PIN 3.5	2- 2	5	192163-84140	CAP 20×49	1-22	3
192163-24500	CENTER CASE CMP.	2- 1	5	192163-84250	UPPER CASE CMP.	1- 2	3
192163-24510	CENTER CASE	2- 4	5	192163-84260	UPPER CASE	1- 3	3
192163-24610	VALVE(A-1 SET	2- 6	5	192163-86140	LEVER BRAKE	9- 3	19
192163-24620	VALVE(A-2 SET	2-16	5	192163-89650	CONTROL SHAFT	6- 2	13
192163-24641	SLEEVE(A1	2- 7	5	192163-89690	CONTROL SHAFT CMP.	6- 1	13
192163-24650	SLEEVE(A2	2-17	5	192163-90250	DIFF. GEAR KIT	7- 1	15
192163-24720	SPRING PUSH PIN	2-13	5	192168-25120	CYLINDER BLOCK	4- 7	9
		2-23	5	192168-25210	CYLINDER BLOCK COMP. SE	4- 6	9
192163-24760	COLLAR 10×20×20	2-27	5	194855-24020	SEALANT	1- 1	3
192163-24900	CONNECTER	2-28	5	194855-24290	CAP. OIL 20	1-10	3
192163-24960	FILTER	2-29	5	194859-24252	VENT VALVE 15	1- 7	3
192163-25050	MOTOR SHAFT SET	4- 3	9	194859-24262	CAP. VENT VALVE	1- 8	3
192163-25110	CYLINDER BLOCK P CMP.	3- 1	7	194859-24270	BODY, VENT VALVE	1- 9	3
192163-25120	CYLINDER BLOCK	3- 3	7	22137-120000	WASHER 12	6- 5	13
192163-25150	PISTON	3- 4	7	22190-080000	WASHER, SEAL 8	1-14	3
192163-25160	SPRING(PISTON	3- 5	7	22252-000350	RING 35	1-15	3

# PARTS INDEX

Part No.	Description	Ref.No.	Page	Part No.	Description	Ref.No.	Page
22272-000050	RING 5	5-12	11				
23871-010000	PLUG PT1/8	2-30	5				
24101-060024	BALL BEARING 6002	4-14	9				
24101-062014	BALL BEARING 6201	4-15	9				
24101-062020	BALL BEARING 6202C3	3-9	7				
24190-120001	BALL 3/8	2-15	5				
		2-25	5				
24311-000050	PACKING P 5	5-13	11				
24311-000110	PACKING P 11	2-26	5				
		2-31	5				
24311-000120	PACKING P 12	6-4	13				
24311-000140	PACKING P 14	2-32	5				
24311-000180	PACKING P 18	1-16	3				
24311-240100	PACKING P 10A	6-6	13				
24421-123207	SEAL TC123207	1-17	3				
24421-153507	SEAL TC153507	1-18	3				
26106-080122	BOLT 8x12	1-19	3				
26106-080202	BOLT 8x20	1-20	3				
26106-100602	BOLT 10x60	2-33	5				
26476-080302	TAPPING, SCREW 8x30	1-21	3				
26776-120002	NUT 12	6-7	13				
792163-84110	TRANSAXLE KIT	0-1	1				



**TUFF TORQ CORPORATION**

5943 COMMERCE BOULEVARD, MORRISTOWN,  
TENN., 37814 U.S.A.

TEL:(423)585-2000  
FAX:(423)585-2003