

Ref	Partnumber	Description	GXV160UH2	Serial Numbers	
001	28400-Z1V-801ZA	STARTER ASSY., RECOIL (LONG ROPE) *NH1 *	1	1090101	
001	28400-Z1V-801ZA	STARTER ASSY., RECOIL (LONG ROPE) *NH1 *	1		
001	28400-Z1V-801ZB	STARTER ASSY., RECOIL (LONG ROPE) *R280	1		
001	28400-Z1V-801ZB	STARTER ASSY., RECOIL (LONG ROPE) *R280	1		
002	28410-Z1V-003ZA	CASE COMP., RECOIL STARTER *R280 *	1		
002	28410-Z1V-003ZB	CASE COMP., RECOIL STARTER *NH1 *	1		
002	28410-Z1V-003ZB	CASE COMP., RECOIL STARTER *NH1 *	1		
003	28420-Z1V-003	REEL, RECOIL STARTER (BLACK)	1		
004	28422-ZH8-801	RATCHET, STARTER	2		
005	28431-ZH8-801	PLATE, FRICTION	1		
006	28433-ZH8-801	GUIDE, RATCHET	1		
007	28441-ZH8-801	SPRING, FRICTION	1		
008	28442-ZH8-003	SPRING, RECOIL STARTER	1		
	<u>Ref</u>	<u>Partnumber</u>	<u>Description</u>	<u>GXV160UH2</u>	<u>Serial Numbers</u>
009	28443-ZH8-801	SPRING, RETURN	2		
010	28461-ZE1-003	KNOB, RECOIL STARTER	1		
012	28462-Z1V-801	ROPE, RECOIL STARTER (LONG) (2360MM)	1		
013	90003-ZH8-801	SCREW, SETTING	1		
014	95701-0600800	BOLT, FLANGE, 6X8	3		

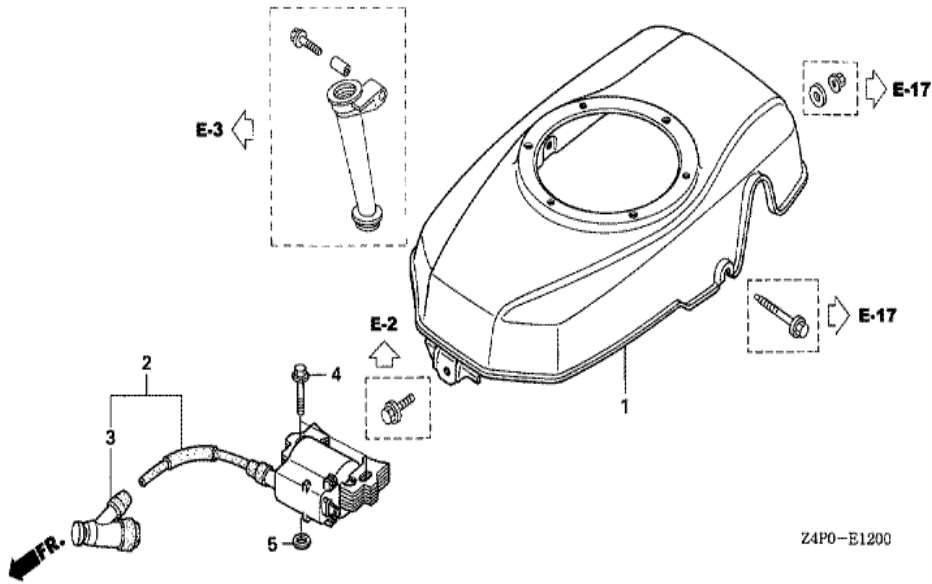

Ref	Partnumber	Description	GXV160UH2	Serial Numbers
001	19610-Z1V-000ZA	COVER COMP., FAN *R280 *	1	
001	19610-Z1V-000ZB	COVER COMP., FAN *NH1 *	1	
001	19610-Z1V-000ZB	COVER COMP., FAN *NH1 *	1	
002	30500-Z1V-013	COIL ASSY., IGNITION	1	
002	30500-Z1V-013	COIL ASSY., IGNITION	1	
003	30700-Z1V-003	CAP ASSY., NOISE SUPPRESSOR	1	
004	90015-883-000	BOLT, FLANGE, 6X28 (CT200)	2	
005	90581-Z1V-000	WASHER, PLAIN, 6MM	2	

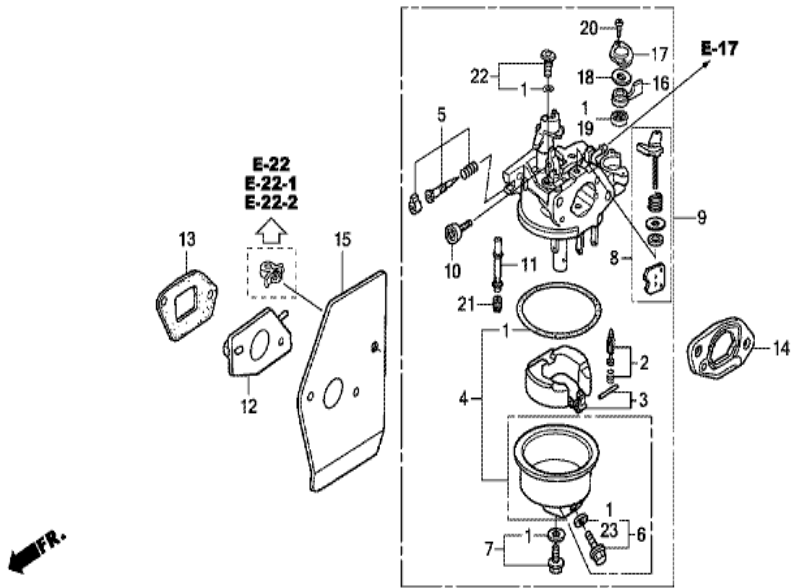

Z4PDE1400C

Ref	Partnumber	Description	GXV160UH2	Serial Numbers
001	16010-ZE0-025	GASKET SET	1	
002	16011-ZE0-005	VALVE SET, FLOAT	1	
003	16013-ZOS-B01	FLOAT SET	1	BE66N A
003	16013-ZE0-005	FLOAT SET	1	BE66M A
003	16013-ZE0-005	FLOAT SET	1	BE66J A
004	16015-ZE0-831	CHAMBER SET, FLOAT	1	
005	16016-ZH7-W01	SCREW SET, PILOT	1	
006	16024-ZE1-811	SCREW SET, DRAIN	1	
007	16028-ZE0-005	SCREW SET	1	
008	16045-Z1V-G01	CHOKE SET	1	BE66N A
008	16045-Z1V-G01	CHOKE SET	1	BE66N A
008	16045-ZE7-005	CHOKE SET	1	BE66M A
008	16045-ZE7-005	CHOKE SET	1	BE66J A

<u>Ref</u>	<u>Partnumber</u>	<u>Description</u>	<u>GXV160UH2</u>	<u>Serial Numbers</u>
009	16100-Z1V-003	CARBURETOR ASSY. (BE66J A)	1	1001679
009	16100-Z1V-801	CARBURETOR ASSY. (BE66N A)	1	1274133
009	16100-Z1V-801	CARBURETOR ASSY. (BE66N A)	1	1001680 1274133
009	16100-Z1V-801	CARBURETOR ASSY. (BE66N A)	1	1001680 1274133
009	16100-Z4P-801	CARBURETOR ASSY. (BEA2C A)	1	1274134
009	16100-Z4P-801	CARBURETOR ASSY. (BEA2C A)	1	1274134
010	16124-ZE0-005	SCREW, THROTTLE STOP	1	
011	16166-Z1V-003	NOZZLE, MAIN	1	BE66J A
011	16166-Z1V-801	NOZZLE, MAIN	1	
011	16166-Z1V-801	NOZZLE, MAIN	1	BE66N A
012	16211-ZE7-000	INSULATOR, CARBURETOR	1	
013	16212-ZE7-M10	PACKING, INSULATOR	1	
013	16212-ZE7-M10	PACKING, INSULATOR	1	
014	16220-ZE6-010	SPACER COMP., CARBURETOR	1	
015	16221-ZE7-M11	PACKING, CARBURETOR	1	
015	16221-ZE7-M11	PACKING, CARBURETOR	1	
016	16953-ZE1-812	LEVER, COCK	1	
017	16954-ZE1-812	PLATE, LEVER SETTING	1	
018	16956-ZE1-811	SPRING, COCK LEVER	1	
019	16957-ZE1-812	PACKING, FUEL COCK	1	
020	93500-030061H	SCREW, PAN, 3X6	2	
021	99101-ZH80600	JET, MAIN, #60	(1)	BE66J A
021	99101-ZH80620	JET, MAIN, #62	(1)	
021	99101-ZH80620	JET, MAIN, #62	(1)	
021	99101-ZH80650	JET, MAIN, #65	1	BE66J A
021	99101-ZH80650	JET, MAIN, #65	(1)	BE66N A
021	99101-ZH80650	JET, MAIN, #65	1	BE66J A
021	99101-ZH80650	JET, MAIN, #65	(1)	BE66N A
021	99101-ZH80650	JET, MAIN, #65	(1)	
021	99101-ZH80680	JET, MAIN, #68	1	BE66N A
021	99101-ZH80680	JET, MAIN, #68	1	BE66N A
022	99204-ZE00350	JET SET, PILOT, #35	1	
023	16141-ZOS-003	WASHER, PLAIN (6.2X10.7 DRAIN)	1	
<u>Ref</u>	<u>Partnumber</u>	<u>Description</u>	<u>GXV160UH2</u>	<u>Serial Numbers</u>
023	16141-ZOS-003	WASHER, PLAIN (6.2X10.7 DRAIN)	1	

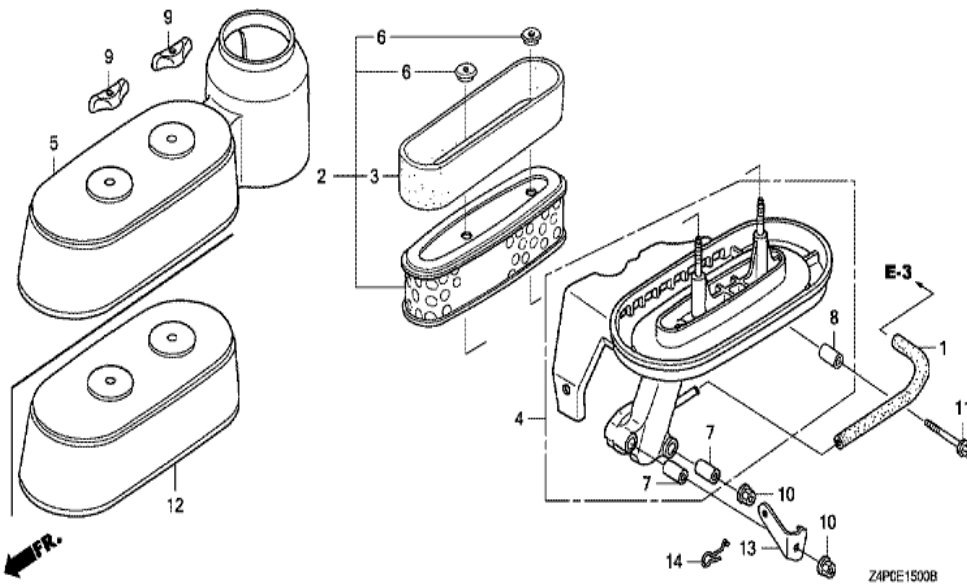

Ref	Partnumber	Description	GXV160UH2	Serial Numbers
001	15721-ZE7-000	TUBE, BREATHER	1	
002	17210-Z1V-003	ELEMENT, AIR CLEANER	1	
003	17218-888-003	FILTER, OUTER	1	
004	17220-Z1V-000	CASE COMP., AIR CLEANER	1	
005	17231-Z1V-000	COVER, AIR CLEANER	1	1036455
006	17232-891-000	GROMMET, AIR CLEANER	2	
007	17238-ZE7-710	COLLAR, AIR CLEANER	2	
008	17239-ZE6-300	COLLAR B, AIR CLEANER	1	
009	90300-Z1V-000	NUT, AIR CLEANER	2	
010	94050-06000	NUT, FLANGE, 6MM	2	
011	95701-0603500	BOLT, FLANGE, 6X35	1	
012	17231-Z1V-G01	COVER, AIR CLEANER	1	
012	17231-Z1V-G01	COVER, AIR CLEANER	1	1036456

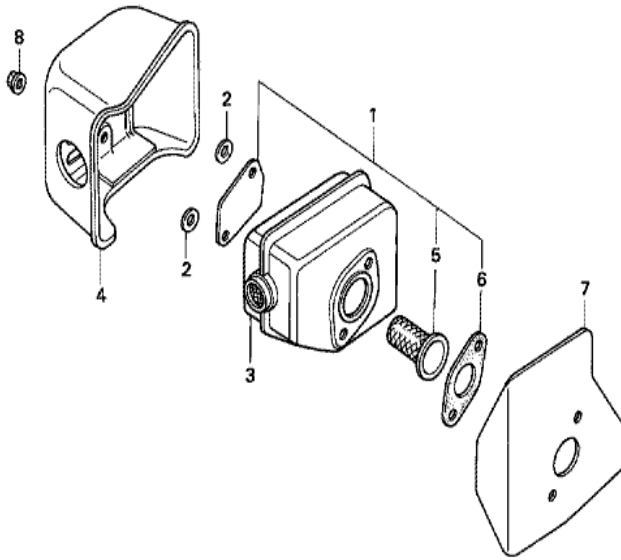

Z4P0-E1600

Ref	Partnumber	Description	GXV160UH2	Serial Numbers
001	06180-ZE6-820	ARRESTER KIT, SPARK	(1)	
001	06180-ZE6-820	ARRESTER KIT, SPARK	(1)	
002	18292-ZE7-M10	PACKING, PROTECTOR	2	
003	18310-Z1V-000	MUFFLER COMP.	1	
004	18320-Z1V-000	PROTECTOR COMP., MUFFLER	1	
005	18355-888-810	ARRESTER, SPARK	(1)	
005	18355-888-810	ARRESTER, SPARK	(1)	
006	18381-ZE6-820	GASKET, MUFFLER	(1)	
006	18381-ZE6-820	GASKET, MUFFLER	(1)	
007	18381-Z1V-000	GASKET, MUFFLER	1	
008	90343-ZE6-000	NUT, SELF-LOCK, 6MM	2	

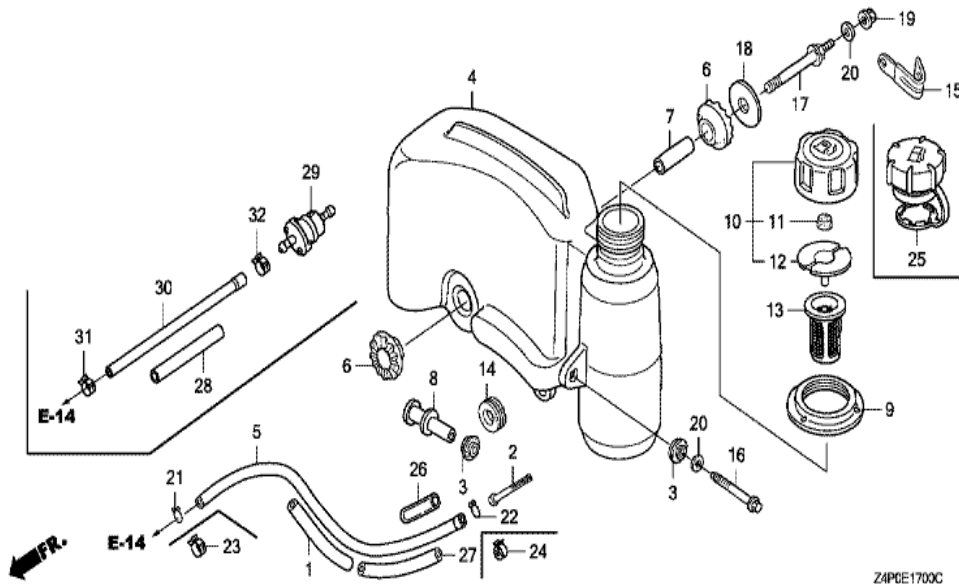

Ref	Partnumber	Description	GXV160UH2	Serial Numbers
001	16854-ZH8-000	RUBBER, SUPPORTER (107MM)	1	
001	16854-ZH8-000	RUBBER, SUPPORTER (107MM)	1	
002	16952-Z1V-000	STRAINER, FUEL	1	
003	17506-ZE7-000	RUBBER, TANK SETTING	2	
004	17510-Z1V-010	TANK COMP., FUEL	1	1036455
004	17510-Z4P-000	TANK COMP., FUEL	1	
004	17510-Z4P-800	TANK COMP., FUEL	1	1036456 1239370
004	17510-Z4P-800	TANK COMP., FUEL	1	1036456 1239370
004	17510-Z4P-810	TANK COMP., FUEL	1	1239371
004	17510-Z4P-810	TANK COMP., FUEL	1	1239371
005	17512-Z4P-003	TUBE, FUEL (FKM)	1	1011284 1038739
005	17512-Z4P-003	TUBE, FUEL (FKM)	1	1011284 1038739
005	17512-Z4P-013	TUBE, FUEL (FKM)	1	1038740 1123369

<u>Ref</u>	<u>Partnumber</u>	<u>Description</u>	<u>GXV160UH2</u>	<u>Serial Numbers</u>
005	17512-Z4P-023	TUBE, FUEL (FKM)	1	1274133
005	17512-Z4P-023	TUBE, FUEL (FKM)	1	1123370 1274133
005	17512-Z4P-023	TUBE, FUEL (FKM)	1	1123370 1274133
005	17512-Z4P-811	TUBE, FUEL (FKM)	1	1274134
005	17512-Z4P-811	TUBE, FUEL (FKM)	1	1274134
005	17512-ZE7-000	TUBE, FUEL	1	1011283
005	17512-ZE7-000	TUBE, FUEL	1	1011283
005	17512-ZE7-000	TUBE, FUEL	1	1011283
006	17516-896-700	RUBBER B, TANK MOUNTING	2	
007	17518-Z1V-000	COLLAR, TANK SET	1	
008	17519-Z1V-000	COLLAR COMP., TANK	1	
009	17532-Z1V-000	RUBBER, TANK MOUNTING	1	1036455
010	17620-Z1V-000	CAP ASSY., FUEL TANK	1	1036455
011	17622-888-010	SPONGE, FUEL CAP BREATHER	1	1036455
012	17624-ZE7-000	PACKING, FUEL CAP	1	1036455
013	17636-Z1V-010	GAUGE, FUEL LEVEL	1	
014	80103-MG2-000	CUSHION, RR. FENDER	1	
016	90014-Z1V-000	BOLT, FLANGE, 6X47 (CT200)	1	
017	90016-Z1V-000	BOLT, TANK STAY	1	
018	90455-896-700	WASHER, TANK MOUNTING	1	
019	94050-06000	NUT, FLANGE, 6MM	1	
020	94103-06000	WASHER, PLAIN, 6MM	2	
021	95002-02080	CLIP, TUBE (B8)	1	1011283
022	95002-70000	CLIP, TUBE (C11)	1	1011283
023	95002-4080008	CLAMP, TUBE (D8)	1	
023	95002-4080008	CLAMP, TUBE (D8)	1	1011284
024	95002-4105008	CLAMP, TUBE (D10.5)	1	
024	95002-4105008	CLAMP, TUBE (D10.5)	1	1011284
025	17620-Z0J-800	CAP ASSY., FUEL TANK	1	
025	17620-Z0J-800	CAP ASSY., FUEL TANK	1	1036456
026	95003-2500320	TUBE, VINYL, 9X11X30 (95003-25001-10M)	1	
026	95003-2500320	TUBE, VINYL, 9X11X30 (95003-25001-10M)	1	1038740
027	16854-ZH8-000	RUBBER, SUPPORTER (107MM)	1	1038739

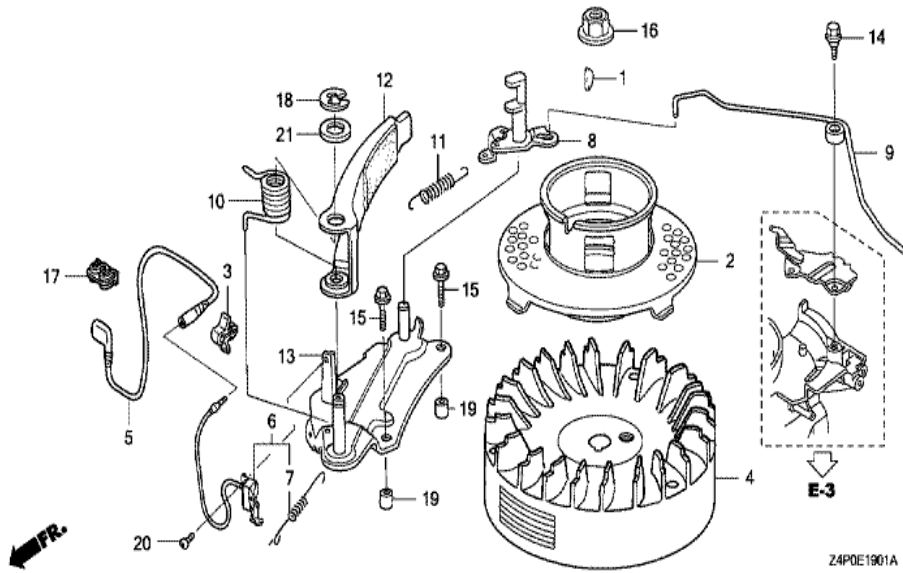

<u>Ref</u>	<u>Partnumber</u>	<u>Description</u>	<u>GXV160UH2</u>	<u>Serial Numbers</u>
001	13331-357-000	KEY, SPECIAL WOODRUFF, 25X18	1	
002	28450-Z1V-000	PULLEY COMP., STARTER	1	
003	30701-883-000	CLIP, HIGH TENSION CORD (8MM)	1	
004	31110-Z1V-810	FLYWHEEL COMP. (BRAKE)	1	1229510
004	31110-Z1V-811	FLYWHEEL COMP. (BRAKE)	1	1229511
005	32195-Z1V-810	CORD, STOP SWITCH (BRAKE)	1	
006	35120-Z1V-811	SWITCH ASSY., ENGINE STOP (BRAKE)	1	
007	35129-Z1V-811	SPRING, SWITCH CONTROL	1	
008	43140-Z1V-000	CAM COMP., BRAKE	1	
009	43145-ZE7-003	ROD, THROTTLE RETURN	1	
010	75112-ZE6-000	SPRING, BRAKE	1	
011	75113-ZE6-000	SPRING, BRAKE RETURN	1	
012	75120-ZE6-013	BRAKE COMP.	1	
<u>Ref</u>	<u>Partnumber</u>	<u>Description</u>	<u>GXV160UH2</u>	<u>Serial Numbers</u>
013	75130-ZE7-000	BASE COMP., BRAKE	1	
014	90015-ZE6-000	BOLT, FLANGE, 6MM	1	
015	90018-ZE1-000	BOLT, FLANGE, 6X23 (CT200)	2	
016	90201-Z1T-000	NUT, SPECIAL, 14MM	1	
017	90505-MCT-000	CLAMP, PIPE	1	
018	90653-723-000	E-RING, 10MM	1	
019	90702-ZE6-000	DOWEL PIN, 8X9	2	
020	93500-040080A	SCREW, PAN, 4X8	1	
021	94102-12800	WASHER, PLAIN, 12MM	1	

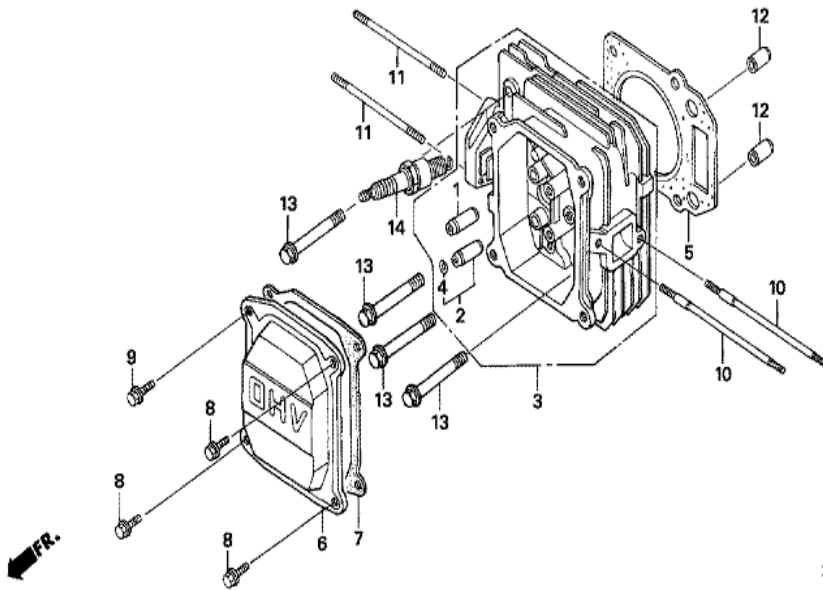

Z4P0-E0200

Ref	Partnumber	Description	GXV160UH2	Serial Numbers
001	12204-ZE1-306	GUIDE, IN. VALVE (OS)	1	
002	12205-ZE1-315	GUIDE, EX. VALVE (OS)	1	
003	12200-ZE7-405	HEAD COMP., CYLINDER	1	
003	12200-ZE7-405	HEAD COMP., CYLINDER	1	
004	12216-ZE5-300	CLIP, VALVE GUIDE	1	
005	12251-Z1V-003	GASKET, CYLINDER HEAD (GUANGZHOU LEAKLES	1	1116223
005	12251-ZE7-000	GASKET, CYLINDER HEAD	1	1116222
005	12251-ZE7-000	GASKET, CYLINDER HEAD	1	1116222
005	12251-ZE7-000	GASKET, CYLINDER HEAD	1	1116222
006	12311-ZG9-800	COVER, HEAD	1	
007	12391-ZE7-M10	PACKING, HEAD COVER	1	
007	12391-ZE7-M10	PACKING, HEAD COVER	1	
008	90013-883-000	BOLT, FLANGE, 6X12 (CT200)	3	1020657
<u>Ref</u>	<u>Partnumber</u>	<u>Description</u>	<u>GXV160UH2</u>	<u>Serial Numbers</u>
008	90014-952-000	BOLT, FLANGE, 6X14 (CT200)	3	
008	90014-952-000	BOLT, FLANGE, 6X14 (CT200)	3	1020658
009	90014-952-000	BOLT, FLANGE, 6X14 (CT200)	1	
010	90043-ZE6-000	BOLT, STUD, 6X109	2	
011	90048-ZC3-000	BOLT, STUD, 6X85	2	
012	94301-10160	DOWEL PIN, 10X16	2	
013	95701-0805000	BOLT, FLANGE, 8X50	4	
014	98079-54846	PLUG, SPARK (BPR4ES) (NGK)	(1)	
014	98079-54855	PLUG, SPARK (W14EPR-U) (DENSO)	(1)	
014	98079-54855	PLUG, SPARK (W14EPR-U) (DENSO)	(1)	
014	98079-55846	PLUG, SPARK (BPR5ES) (NGK)	1	
014	98079-55846	PLUG, SPARK (BPR5ES) (NGK)	1	
014	98079-55855	PLUG, SPARK (W16EPR-U) (DENSO)	1	
014	98079-55855	PLUG, SPARK (W16EPR-U) (DENSO)	1	
014	98079-56846	PLUG, SPARK (BPR6ES) (NGK)	(1)	
014	98079-56846	PLUG, SPARK (BPR6ES) (NGK)	(1)	
014	98079-56855	PLUG, SPARK (W20EPR-U) (DENSO)	(1)	
014	98079-56855	PLUG, SPARK (W20EPR-U) (DENSO)	(1)	

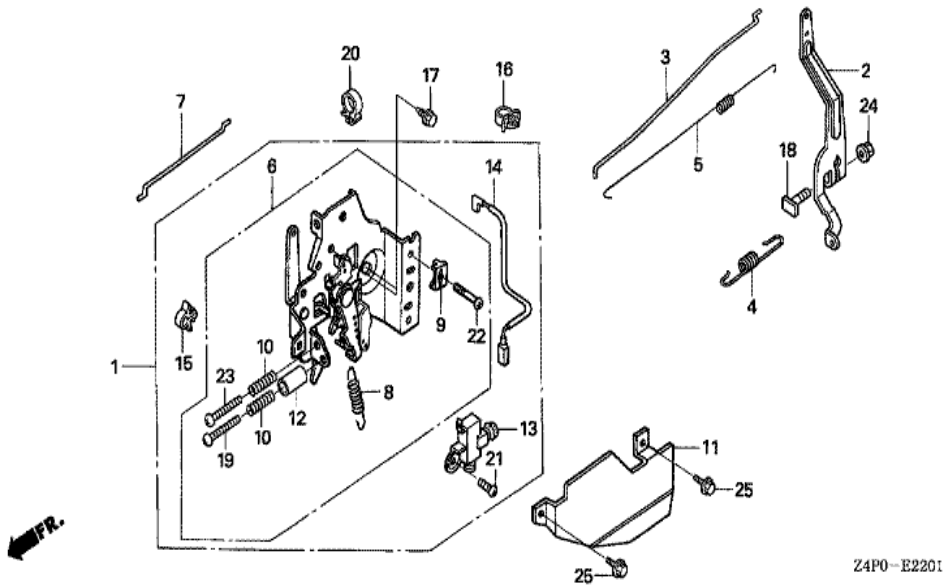

Z4P0 - E2201

<u>Ref</u>	<u>Partnumber</u>	<u>Description</u>	<u>GXV160UH2</u>	<u>Serial Numbers</u>
002	16551-ZE7-000	ARM, GOVERNOR	1	
003	16555-ZE7-000	ROD, GOVERNOR	1	
004	16561-ZE7-020	SPRING, GOVERNOR	1	
005	16562-ZE6-000	SPRING, THROTTLE RETURN	1	
006	16570-ZE7-W20	CONTROL COMP. (EN) (BRILL)	1	
006	16570-ZE7-W20	CONTROL COMP. (EN) (BRILL)	1	
007	16573-ZE7-000	ROD, CHOKE	1	
008	16576-ZE7-300	SPRING, LEVER	1	
009	16576-891-000	HOLDER, CABLE	1	
010	16584-883-300	SPRING, CONTROL ADJUSTING	2	
011	16585-ZE7-000	PROTECTOR, CONTROL	1	
012	16599-ZG1-M10	COLLAR, STOPPER	1	
017	90013-883-000	BOLT, FLANGE, 6X12 (CT200)	2	
<u>Ref</u>	<u>Partnumber</u>	<u>Description</u>	<u>GXV160UH2</u>	<u>Serial Numbers</u>
018	90015-ZE5-010	BOLT, GOVERNOR ARM	1	
019	90016-ZE7-W00	SCREW, RECESSED, 5X28	1	
020	90659-680-013	CLIP, WIRE HARNESS	1	
022	93500-050160A	SCREW, PAN, 5X16	1	
023	93500-050200A	SCREW, PAN, 5X20	1	
024	94050-06000	NUT, FLANGE, 6MM	1	
025	95701-0601000	BOLT, FLANGE, 6X10	2	

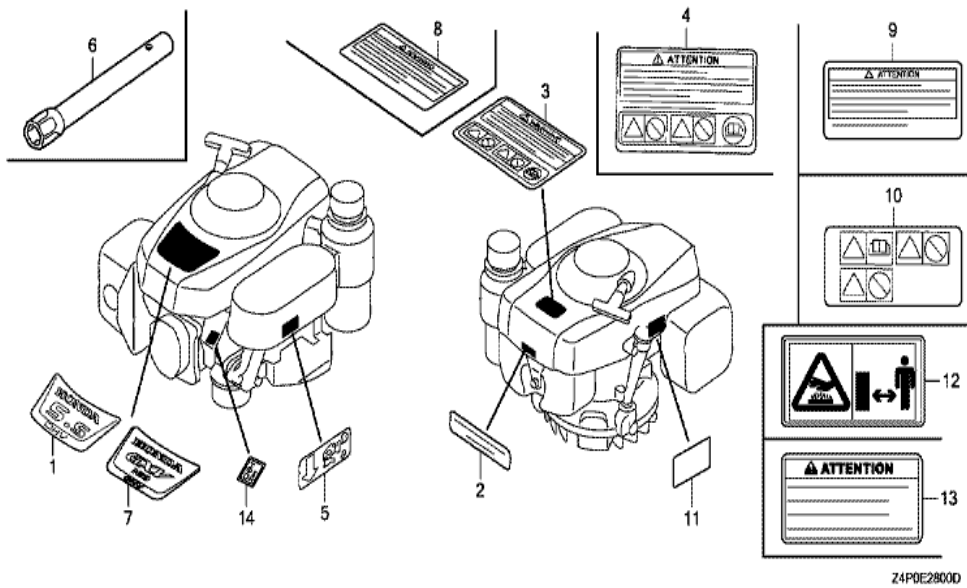

Z4PDE2800D

<u>Ref</u>	<u>Partnumber</u>	<u>Description</u>	<u>GXV160UH2</u>	<u>Serial Numbers</u>
001	87101-Z1V-000	MARK, EMBLEM (GXV160 5.5)	1	1036455
002	87504-Z1V-000	MARK, MANUFACTURER	1	
003	87516-Z4N-000	MARK, OPERATOR CAUTION (ENGLISH) (MADE I	1	1133623
003	87516-Z4N-810	MARK, OPERATOR CAUTION (PICTOGRAPH) (MAD	(1)	1133623
003	87516-Z4N-810	MARK, OPERATOR CAUTION (PICTOGRAPH) (MAD	(1)	1133623
004	87516-Z4N-800	MARK, OPERATOR CAUTION (FRENCH) (MADE IN	1	1133623
005	87524-Z1V-000	MARK, FUEL COCK CAUTION	1	
007	87101-Z1V-010	MARK, EMBLEM (GXV160)	1	1036456 1046647
007	87101-Z1V-020	MARK, EMBLEM (GXV160)	1	
007	87101-Z1V-020	MARK, EMBLEM (GXV160)	1	1046648
008	87516-Z4N-010	MARK, OPERATOR CAUTION (ENGLISH)	1	
008	87516-Z4N-010	MARK, OPERATOR CAUTION (ENGLISH)	1	1133624
009	87516-Z4N-801	MARK, OPERATOR CAUTION (FRENCH)	1	1133624
<u>Ref</u>	<u>Partnumber</u>	<u>Description</u>	<u>GXV160UH2</u>	<u>Serial Numbers</u>
010	87519-Z4N-000	MARK, OPERATOR CAUTION (PICTOGRAPH)	1	
010	87519-Z4N-000	MARK, OPERATOR CAUTION (PICTOGRAPH)	1	1133624
011	87539-Z0J-000	MARK, EX. CAUTION (ENGLISH)	1	
011	87539-Z0J-000	MARK, EX. CAUTION (ENGLISH)	1	1133624
011	87539-Z0J-810	MARK, EX. CAUTION (FRENCH)	1	1133624
011	87539-Z0J-810	MARK, EX. CAUTION (FRENCH)	1	1133624

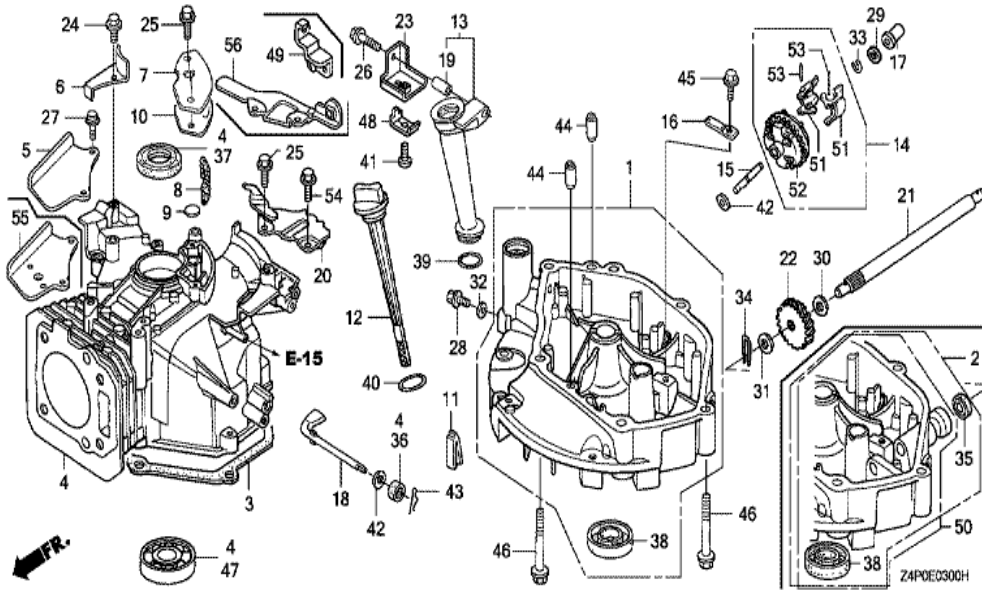

Ref	Partnumber	Description	GXV160UH2	Serial Numbers
001	11300-Z1V-406	PAN ASSY., OIL	1	
001	11300-Z1V-406	PAN ASSY., OIL	1	
003	11381-ZE7-M10	PACKING, OIL PAN	1	
003	11381-ZE7-M10	PACKING, OIL PAN	1	
004	12000-Z1V-405	BARREL ASSY., CYLINDER	1	
004	12000-Z1V-405	BARREL ASSY., CYLINDER	1	
006	12126-Z1V-800	PLATE A, GUIDE	1	
006	12126-Z1V-800	PLATE A, GUIDE	1	
007	12355-Z1V-000	COVER COMP., BREATHER	1	
008	12367-883-003	FILTER, BREATHER	1	
009	12372-ZE7-000	VALVE, BREATHER	1	
010	12373-ZE7-000	PACKING, BREATHER COVER	1	
011	15335-ZE7-000	RUBBER, OIL RETURN	1	

<u>Ref</u>	<u>Partnumber</u>	<u>Description</u>	<u>GXV160UH2</u>	<u>Serial Numbers</u>
012	15620-ZE6-810	GAUGE COMP., OIL LEVEL	1	
013	15630-ZE6-810	EXTENSION, OIL FILLER	1	
014	16510-ZE6-000	GOVERNOR ASSY.	1	
015	16515-ZE6-010	SHAFT, GOVERNOR HOLDER	1	
016	16525-ZE6-010	PLATE, GOVERNOR SHAFT HOLDER	1	
017	16531-Z1T-000	SLIDER, GOVERNOR	1	
018	16541-ZE7-000	SHAFT, GOVERNOR ARM	1	
019	17240-ZE6-000	COLLAR, EXTENSION	1	
020	17560-Z1V-000	STAY COMP., TANK	1	
023	43143-Z1V-000	BASE COMP., HOLDER	1	
024	90013-883-000	BOLT, FLANGE, 6X12 (CT200)	1	
025	90014-952-000	BOLT, FLANGE, 6X14 (CT200)	3	
025	90014-952-000	BOLT, FLANGE, 6X14 (CT200)	3	
026	90017-883-000	BOLT, FLANGE, 6X32 (CT200)	1	
028	90131-ZE1-000	BOLT, DRAIN PLUG	1	
029	90451-ZE1-000	WASHER, THRUST, 6MM	1	
029	90451-ZE1-000	WASHER, THRUST, 6MM	1	
032	90601-ZE1-000	WASHER, DRAIN PLUG, 10.2MM	1	
033	90602-ZE1-000	CLIP, GOVERNOR HOLDER	1	
036	91231-Z1V-003	OIL SEAL, 6X11X4 (ARAI)	1	
037	91251-Z1V-003	OIL SEAL, 25X38X7 (ARAI)	1	
038	91252-Z1V-003	OIL SEAL, 25.4X40X7	1	
039	91301-Z1V-003	O-RING, 22.1X2.2	1	
040	91302-Z1V-003	O-RING, 25.5X3	1	
041	93500-050160A	SCREW, PAN, 5X16	1	
042	94101-06800	WASHER, PLAIN, 6MM	2	
043	94251-08000	PIN, LOCK, 8MM	1	
044	94301-08140	DOWEL PIN, 8X14	2	
045	95701-0601208	BOLT, FLANGE, 6X12	1	
046	95701-0805000	BOLT, FLANGE, 8X50	6	
047	96100-6205000	BEARING, RADIAL BALL, 6205	1	
048	16576-891-000	HOLDER, CABLE	1	
051	16511-ZE1-000	WEIGHT, GOVERNOR	2	
<u>Ref</u>	<u>Partnumber</u>	<u>Description</u>	<u>GXV160UH2</u>	<u>Serial Numbers</u>
052	16512-ZE6-000	HOLDER, GOVERNOR WEIGHT	1	
053	16513-ZE1-000	PIN, GOVERNOR WEIGHT	2	

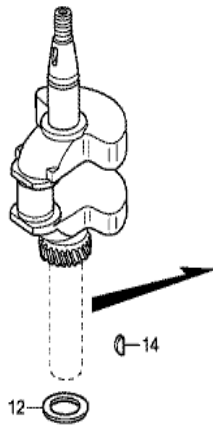

FR.

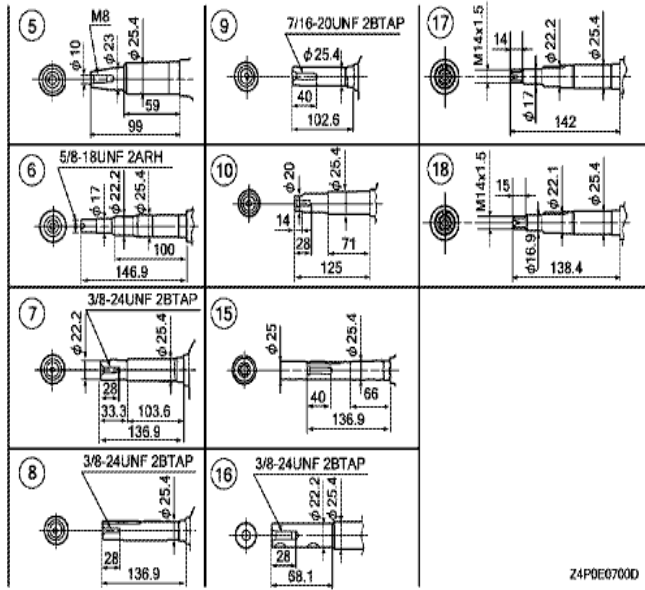

Z4P0E07000

Ref	Partnumber	Description	GXV160UH2	Serial Numbers
007	13310-ZE7-010	CRANKSHAFT COMP.	1	
012	90401-ZE7-W00	WASHER, THRUST, 25.6MM	1	
014	90741-ZV4-000	KEY, SPECIAL, 16X15	1	

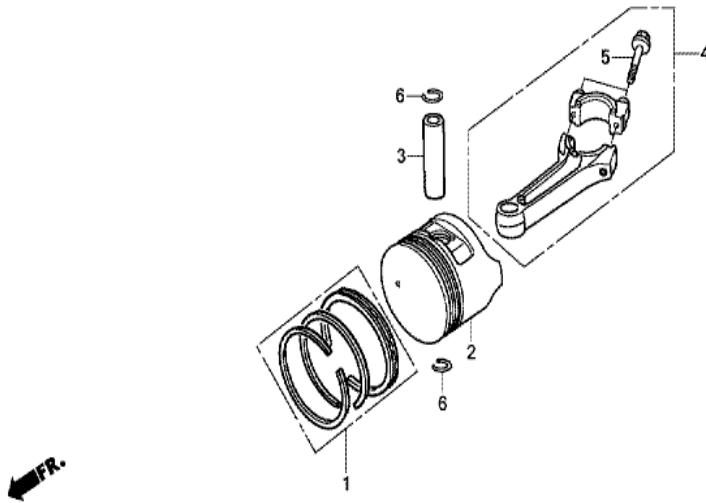

Z4P0E0800

Ref	Partnumber	Description	GXV160UH2	Serial Numbers
001	13010-Z4K-004	RING SET, PISTON (STD.) (TPR)	1	
001	13010-Z4P-003	RING SET, PISTON (STD.) (RIKEN)	1	1036456
001	13010-ZL0-003	RING SET, PISTON (STD.) (TEIKOKU)	1	1036455
001	13010-ZL0-004	RING SET, PISTON (STD.) (NIPPON)	1	1036455
001	13011-Z4K-004	RING SET, PISTON (0.25) (TPR)	(1)	
001	13011-Z4P-003	RING SET, PISTON (0.25) (RIKEN)	(1)	1036456
001	13011-ZL0-003	RING SET, PISTON (0.25) (TEIKOKU)	(1)	1036455
001	13011-ZL0-004	RING SET, PISTON (0.25) (NIPPON)	(1)	1036455
001	13012-Z4K-004	RING SET, PISTON (0.50) (TPR)	(1)	
001	13012-Z4P-003	RING SET, PISTON (0.50) (RIKEN)	(1)	1036456
001	13012-ZL0-003	RING SET, PISTON (0.50) (TEIKOKU)	(1)	1036455
001	13012-ZL0-004	RING SET, PISTON (0.50) (NIPPON)	(1)	1036455
001	13013-Z4K-004	RING SET, PISTON (0.75) (TPR)	(1)	
<u>Ref</u>	<u>Partnumber</u>	<u>Description</u>	<u>GXV160UH2</u>	<u>Serial Numbers</u>
001	13013-Z4P-003	RING SET, PISTON (0.75) (RIKEN)	(1)	1036456
001	13013-ZL0-003	RING SET, PISTON (0.75) (TEIKOKU)	(1)	1036455
001	13013-ZL0-004	RING SET, PISTON (0.75) (NIPPON)	(1)	1036455
002	13101-Z1T-000	PISTON (STD.) (JIALING-HONDA)	1	1036455
002	13101-Z1T-010	PISTON (STD.) (JIALING-HONDA)	1	1036456
002	13102-ZE7-020	PISTON (0.25)	(1)	1036455
002	13102-ZH8-020	PISTON (0.25)	(1)	
002	13103-ZE7-020	PISTON (0.50)	(1)	1036455
002	13103-ZH8-020	PISTON (0.50)	(1)	
002	13104-ZE7-020	PISTON (0.75)	(1)	1036455
002	13104-ZH8-020	PISTON (0.75)	(1)	
003	13111-Z1T-000	PIN, PISTON	1	
004	13200-Z1V-000	ROD ASSY., CONNECTING	1	
005	90001-ZE1-000	BOLT, CONNECTING ROD	2	
006	90551-ZE1-000	CLIP, PISTON PIN, 18MM	2	

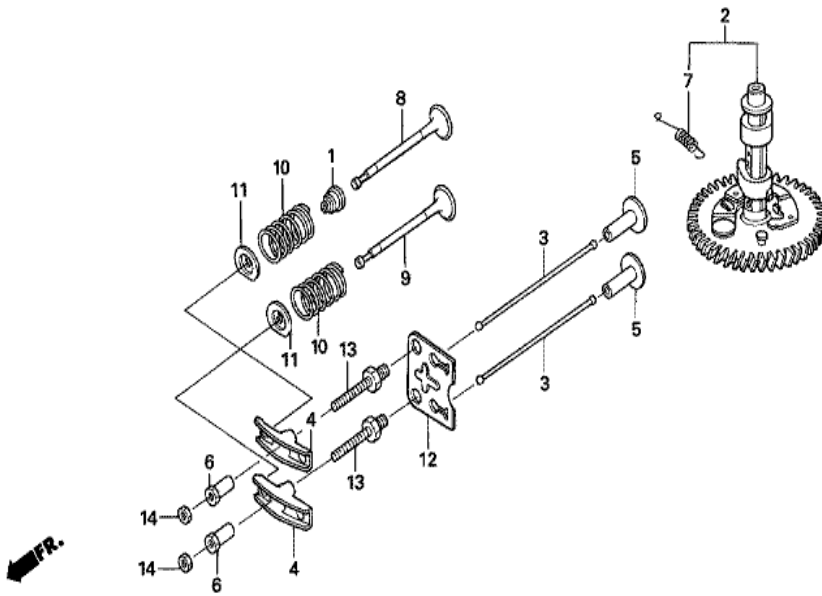

Z4P0-E0900

<u>Ref</u>	<u>Partnumber</u>	<u>Description</u>	<u>GXV160UH2</u>	<u>Serial Numbers</u>
001	12209-ZE6-003	SEAL, VALVE STEM	1	
002	14100-ZE7-000	CAMSHAFT ASSY.	1	
003	14410-ZE1-010	ROD, PUSH	2	
004	14431-ZE1-000	ARM, VALVE ROCKER	2	
005	14441-ZE1-010	LIFTER, VALVE	2	
006	14451-ZE1-013	PIVOT, ROCKER ARM	2	
006	14451-ZE1-013	PIVOT, ROCKER ARM	2	
007	14568-ZE1-000	SPRING, WEIGHT RETURN	1	
008	14711-ZF1-000	VALVE, IN.	1	
009	14721-ZE7-000	VALVE, EX.	1	
010	14751-ZE1-000	SPRING, VALVE	2	
011	14771-ZE1-000	RETAINER, IN. VALVE SPRING	2	
012	14791-ZE1-010	PLATE, PUSH ROD GUIDE	1	
<u>Ref</u>	<u>Partnumber</u>	<u>Description</u>	<u>GXV160UH2</u>	<u>Serial Numbers</u>
013	90012-ZE0-010	BOLT, PIVOT, 8MM	2	
014	90206-ZE1-000	NUT, PIVOT ADJUSTING	2	