

ILLUSTRATED PARTS LIST

MFG. ID NO. 96041026501

CUSTOMER CATALOG NO. GTH3052TF

PRODUCT NO. 960 41 02-65



443843

**TRACTOR - - MODEL NO. GTH3052TF (96041026501), PRODUCT NO. 960 41 02-65
DECALS 27**

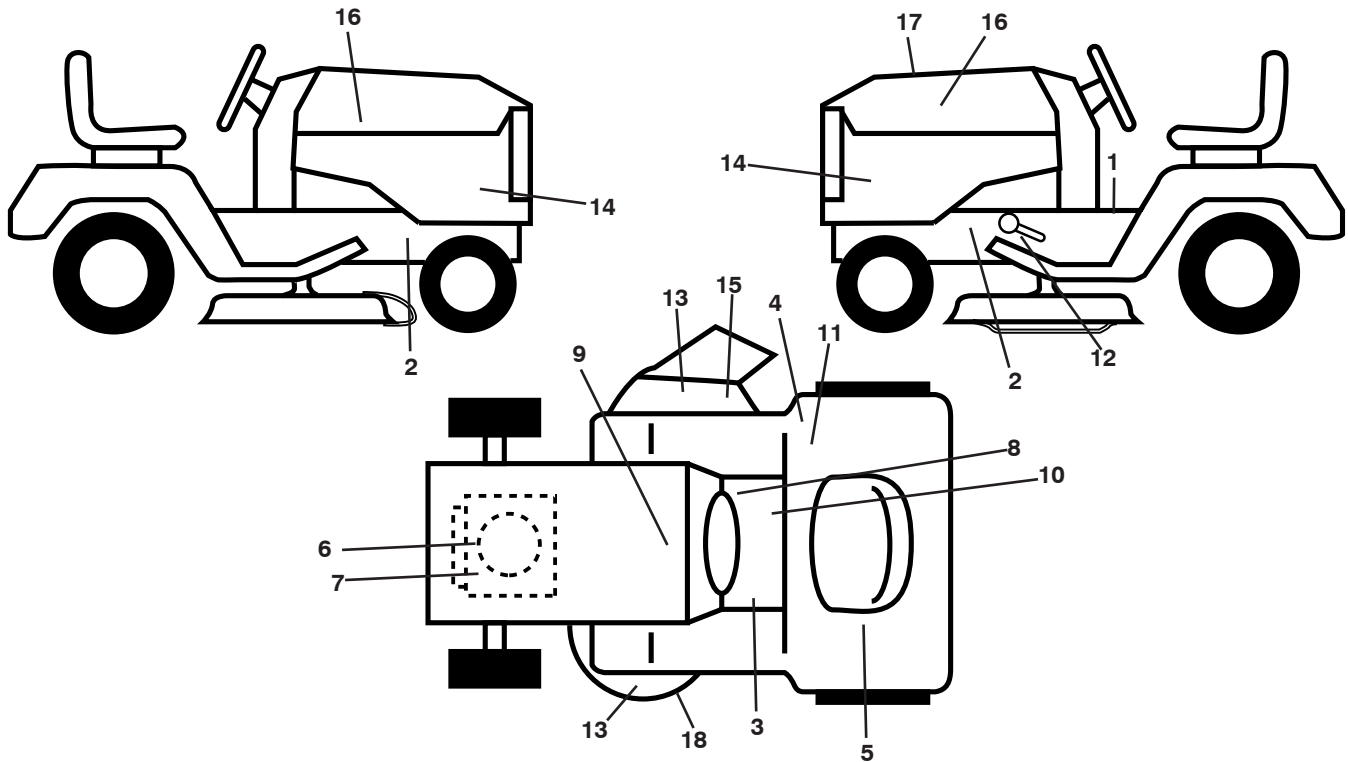

KEY NO.	PART NO.	DESCRIPTION
1	532 40 03-89	Decal, Operator's
2	532 15 97-36	Decal, Hot Muffler
3	532 15 97-37	Decal, Brake Clutch
4	532 12 44-33	Decal, 80 DBA
5	532 42 62-09	Decal, Warning Reserve
6	532 44 47-73	Decal, Eng. H.P.
7	532 19 68-41	Decal, Warning Eng. Sym.
8	532 14 08-37	Decal, Brake Parking
9	532 14 50-05	Decal, Battery Dnge/Poi
10	532 17 83-02	Decal, Oper. Cruise Sym.
11	532 16 88-69	Decal, Tick Mark
12	532 41 86-00	Decal, Pedal

KEY NO.	PART NO.	DESCRIPTION
13	581 72 43-01	Decal, No Step
14	532 44 40-02	Decal, Panel Side
15	539 11 32-24	Decal, Warning
16	581 62 73-01	Decal, Hood Logo
17	532 44 38-43	Decal, Replacement
18	532 19 87-85	Decal, Mower Sch.
--	532 16 25-98	Decal, Load Limit
--	532 16 69-60	Decal, Bypass
--	532 43 98-82	Pad, Footrest, LH
--	532 43 98-81	Pad, Footrest, RH
--	580 30 29-26	Manual, Operator's (Eng)

WHEELS AND TIRES

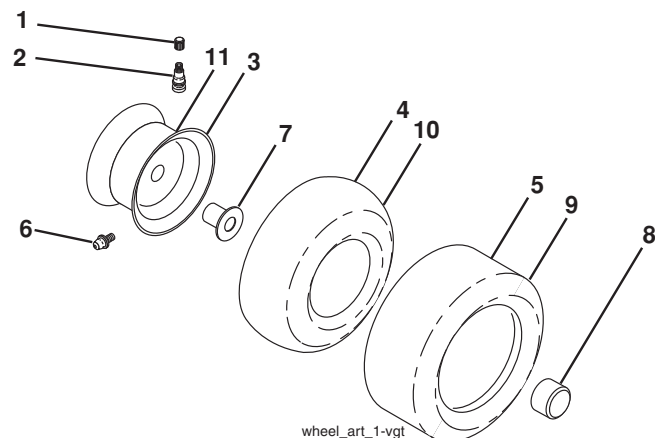

KEY NO.	PART NO.	DESCRIPTION
1	532 05 91-92	Cap, Valve, Tire
2	532 06 51-39	Stem, Valve
3	532 44 42-85	Rim Assembly, Front
4	532 00 81-34	Tube, Front (Service Item Only)
5	532 10 62-30	Tire, Front
6	532 12 49-57	Fitting, Grease (Front Wheel Only)
7	532 12 49-59	Bearing, Flange (Front Wheel Only)
8	532 17 50-39	Cap, Axle
9	532 10 55-88	Tire, Rear
10	532 00 71-54	Tube, Rear (Service Item Only)
11	532 14 45-10	Rim Assembly, Rear
--	532 14 43-34	Sealant, Tire (10 oz. Tube)

NOTE: All component dimensions given in U.S. inches
1 inch = 25.4 mm

TRACTOR - - MODEL NO. GTH3052TF (96041026501), PRODUCT NO. 960 41 02-65
 ELECTRICAL **32**

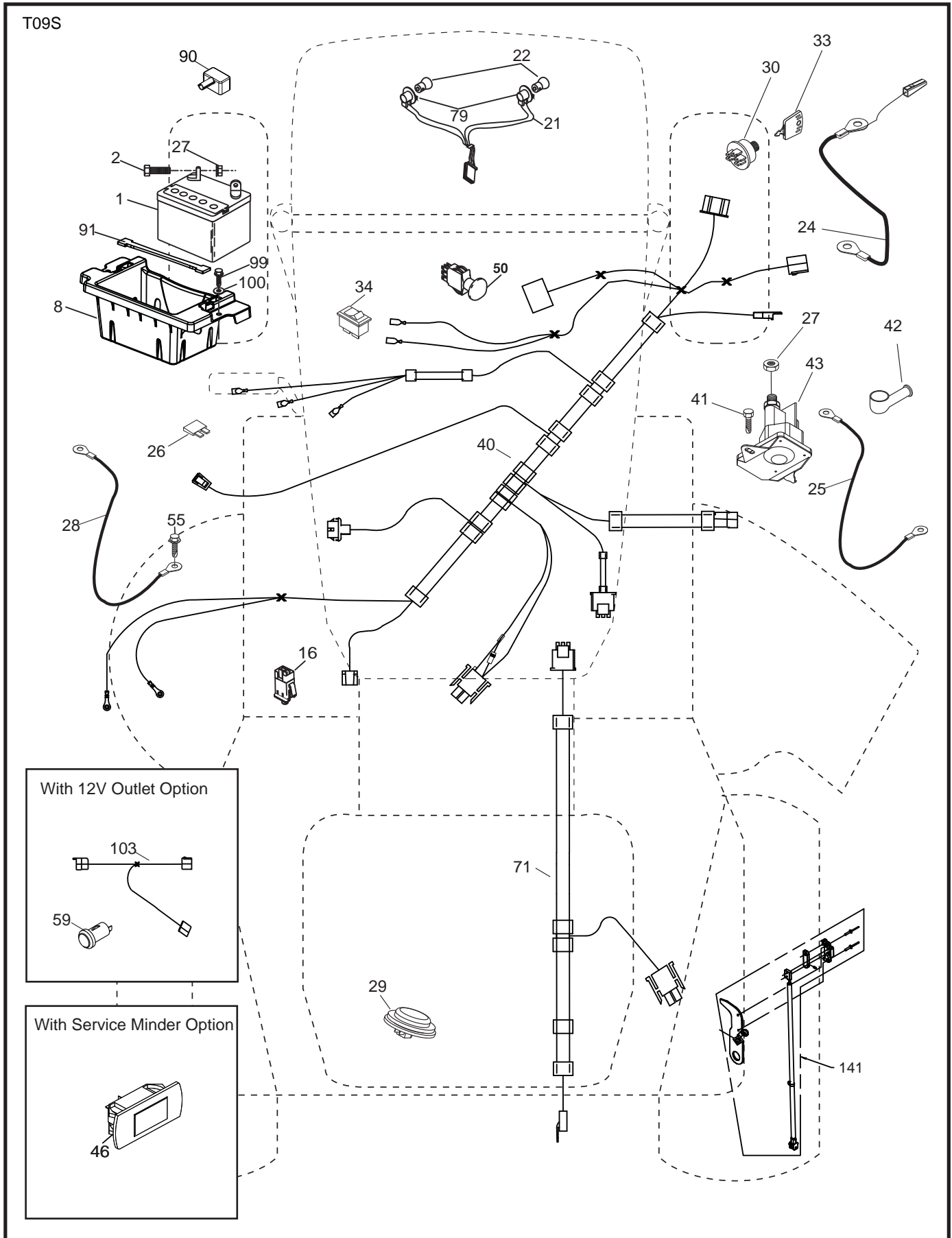

**TRACTOR - - MODEL NO. GTH3052TF (96041026501), PRODUCT NO. 960 41 02-65
ELECTRICAL 32**

KEY NO.	PART NO.	DESCRIPTION
1	532 16 34-65	Battery
2	874 76 04-12	Bolt Hex Hd 1/4-20 unc x 3/4
8	532 18 64-91	Battery Box
16	532 17 61-38	Switch Interlock
21	532 40 02-52	Harness Socket Light
22	532 00 41-52	Bulb, Light #1156
24	532 40 02-53	Cable Battery
25	532 41 28-95	Cable Starter
26	532 17 51-58	Fuse
27	873 51 04-00	Nut Keps Hex 1/4-20 unc
28	532 14 54-91	Cable Ground 21" Blk 6 Ga.
29	532 40 15-45	Switch Seat
30	532 19 33-50	Switch Ign
33	532 41 19-33	Key/Chain
34	532 11 07-12	Switch Light/Reset
40	532 40 11-04	Harness Dash
41	817 72 04-08	Screw 1/4-20 unc x 1/2
42	532 13 15-63	Cover Terminal Red
43	532 19 25-07	Solenoid
46	532 40 17-63	Gauge Hourmeter
50	532 17 46-51	Switch PTO
55	817 06 05-12	Screw Thdrol 5/16-18 x 3/4
71	532 19 42-76	Harness Ign
79	532 17 52-42	Socket Asm. Bulb Twistlock
90	532 43 53-95	Cover Terminal Battery
91	532 19 02-70	Strap Battery
99	817 67 04-12	Screw Hexwsh Thdrol 1/4-20 x 3/4
100	819 09 14-16	Washer 9/32 x 7/8 x 16 Ga.
141	532 42 12-25	Kit G700/G730 ROS

NOTE: All component dimensions given in U.S. inches
1 inch = 25.4 mm

TRACTOR - - MODEL NO. GTH3052TF (96041026501), PRODUCT NO. 960 41 02-65
CHASSIS AND ENCLOSURES **39**

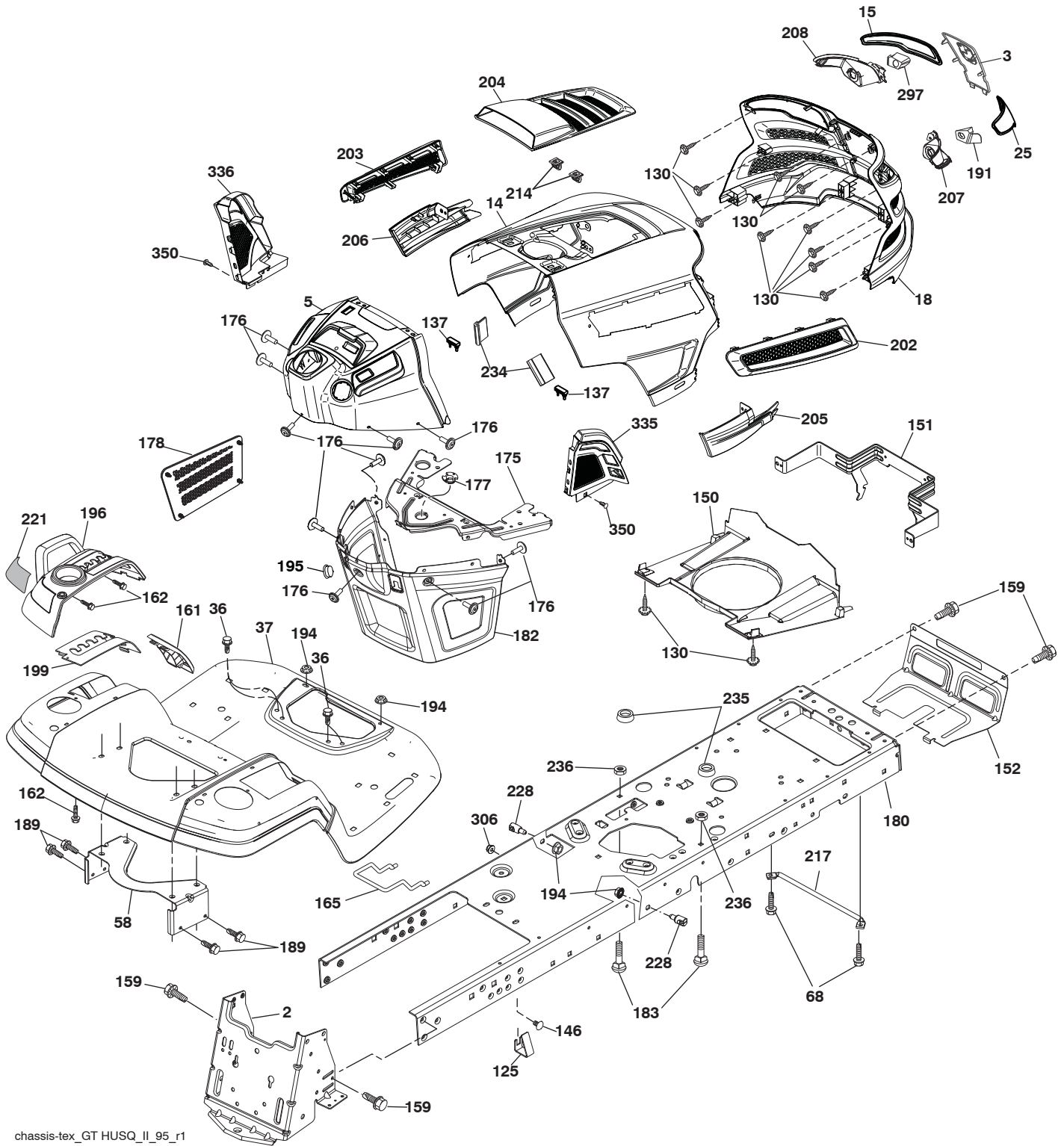

chassis-tex_GT HUSQ_II_95_r1

**TRACTOR - - MODEL NO. GTH3052TF (96041026501), PRODUCT NO. 960 41 02-65
CHASSIS AND ENCLOSURES 39**

KEY NO.	PART NO.	DESCRIPTION
2	580 43 44-01	Drawbar
3	532 43 97-52	Logo Husq.
5	532 43 74-71	Dash
14	532 44 11-77	Hood
15	532 43 97-33	Lens LH
18	532 43 77-62	Grille Asm
25	532 44 33-85	Lens RH
36	817 06 05-12	Screw 5/16-18 x 3/4
37	532 44 12-08	Fender
58	532 19 43-14	Bracket Fender
68	817 49 05-08	Screw 5/16-18 x 1/2
125	581 68 48-01	Clip Fuel Line
130	532 41 63-58	Screw #10 x 0.750 BOS Thread
137	532 40 75-90	Bumper Dash
146	581 85 79-01	Bolt
150	532 43 97-74	Duct Heat Hood
151	532 43 66-70	Bracket Pivot Hood
152	532 19 43-29	Shield Browning
159	817 00 06-12	Screw 3/8-16 x 3/4
161	532 43 99-29	Console Fuel Window
162	532 14 24-32	Screw Hex Wsh Hi-Lo 1/4 x 1/2
165	532 19 43-30	Bracket Support Tank
175	532 19 63-04	Crossmember
176	532 40 07-76	Screw 10-24 x 5/8 Wshd Qdrx
177	532 19 52-27	Bushing Steering
178	532 19 97-82	Cargo Asm. Net
180	532 44 55-59	Chassis
182	532 40 68-59	Dash Lower
183	874 52 05-20	Bolt 5/16-18 x 1-1/4
189	817 00 05-12	Screw 5/16-18 x 3/4

KEY NO.	PART NO.	DESCRIPTION
191	532 43 74-55	Insert Reflect. RH
194	873 90 05-00	Nut Lock Hex Flange 5/16-18
195	532 40 41-37	Plug
196	532 43 96-74	Console Asm. Deck Lift
199	532 19 82-59	Plate Deck Lift
202	532 43 97-28	Vent Side Hood RH
203	532 43 97-27	Vent Side Hood LH
204	532 43 57-14	Vent Asm Hood Top
205	532 43 97-30	Skirt Hood Side RH
206	532 43 97-29	Skirt Hood Side LH
207	532 43 97-34	Bezel RH
208	532 43 97-35	Bezel LH
214	532 19 91-45	Clip Retainer
217	532 40 91-67	Rod Pivot
221	532 19 89-09	Reflector LH
228	532 19 51-61	Stud Fastener
234	532 40 47-42	Bumper Hood
235	532 40 61-29	Spacer Fender
236	873 93 05-00	Nut Center Lock 5/16-18 unc
297	532 43 74-56	Insert Reflect. LH
306	873 90 06-00	Nut Lock
335	532 44 82-04	Cover RH Lower
336	532 44 53-09	Cover LH Lower
350	532 44 51-43	Clip X-mas Tree
--	532 42 49-18	Kit Guard Brush

NOTE: All component dimensions given in U.S. inches
1 inch = 25.4 mm

TRACTOR - - MODEL NO. GTH3052TF (96041026501), PRODUCT NO. 960 41 02-65
 DRIVE **40**

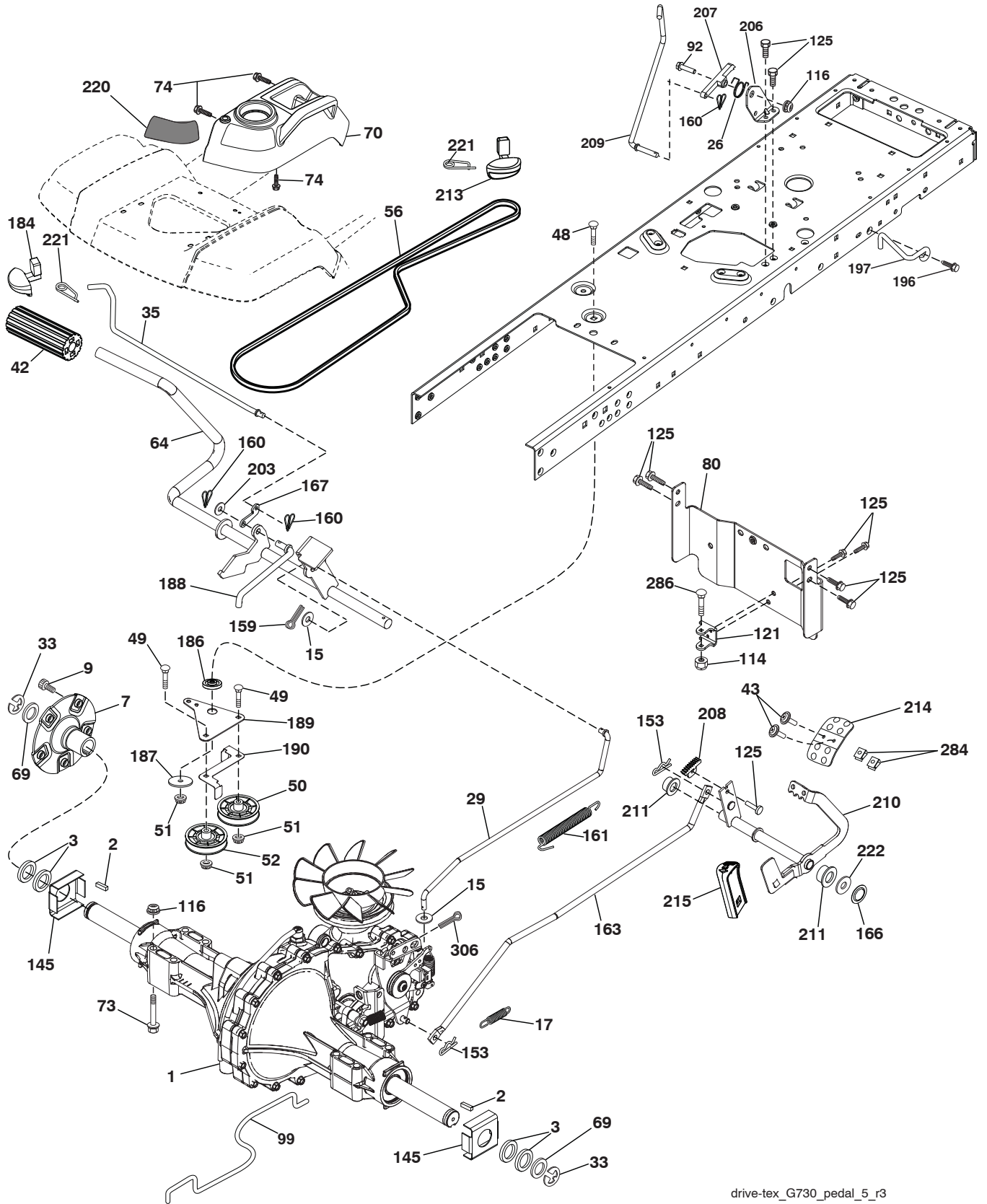

drive-tex_G730_pedal_5_r3

**TRACTOR - - MODEL NO. GTH3052TF (96041026501), PRODUCT NO. 960 41 02-65
DRIVE **40****

KEY NO.	PART NO.	DESCRIPTION
1	-----	Transaxle, Hydro G7-BCBB-1XDC-1FCA (420331) (Order parts from transaxle manufacturer.)
2	532 00 70-70	Key 1/4 x 2.5
3	532 00 75-63	Washer Thrust Axle Hardened
7	532 19 98-37	Hub Asm. Wheel
9	532 14 00-80	Bolt Hub Wheel
15	819 13 13-16	Washer 13/32 x 13/16 x 16 Ga.
17	532 19 72-96	Spring, Brake
26	532 19 96-79	Spring Return Cruise
29	532 41 81-86	Rod, Brake
33	812 00 00-53	Ring E
35	583 86 46-01	Rod, Brake, Park
42	532 12 48-72	Cover, Foot Pedal
43	874 18 04-12	Screw Mach. CR. 1/4-20 x 3/4
48	872 11 06-12	Bolt Carr Sh 3/8-16 x 1-1/2 Gr.5
49	872 11 06-14	Bolt
50	532 19 43-27	Pulley Idler Flat
51	873 90 06-00	Lock Nut 3/8-16
52	532 19 43-26	Idler V-Groove
56	532 42 08-07	V-Belt, Drive
64	532 19 78-65	Shaft Asm. Pedal Brake Control
69	532 12 38-00	Washer 1-1/32 x 1-5/8 x 16 Ga.
70	532 43 96-61	Console Asm
73	874 49 05-48	Bolt Hex 5/16-18 x 3 Gr. 5
74	532 14 24-32	Screw 1/4 x 1/2
80	532 41 81-84	Strap Torque
92	874 76 05-20	Bolt 5/16-18 x 1/2
99	532 41 81-88	Spring Bypass
114	873 80 05-00	Nut Lock Hex W/Ins. 5/16-18 unc
116	873 90 05-00	Nut Lock Hex Flange 5/16-18
121	532 17 56-11	Bracket Strap Torque
125	817 00 05-12	Screw 5/16-18 x 3/4
145	532 16 31-68	Washer Axle Flange

KEY NO.	PART NO.	DESCRIPTION
153	532 12 47-88	Retainer Spring
159	876 02 04-12	Pin Cotter 1/8 x 3/4
160	532 16 94-84	Retainer Clip
161	532 10 57-09	Spring, Return, Clutch
163	532 41 81-85	Rod Pedal Control
166	532 42 91-64	Nut Push .625
167	532 40 52-57	Latch Brake Parking
184	532 44 14-55	Handle Parking Brake
186	532 19 43-21	Spacer Retainer
187	819 13 32-10	Washer
188	532 19 43-23	Link Clutch Ground Drive
189	532 40 75-04	Bellcrank Ground Drive
190	532 40 75-05	Keeper Bellcrank Ground Drive
196	817 00 06-16	Screw 3/8-16 x 1
197	532 19 97-69	Bracket Clutch Anti-Rotation
203	819 11 11-16	Washer 11/32 x 11/16 x 16 Ga.
206	532 19 78-67	Bracket Mount Latch Cruise
207	532 19 78-68	Latch Control Cruise
208	532 19 78-69	Gear Sector Control Cruise
209	532 19 95-92	Rod Control Cruise
210	532 19 78-60	Rocker Asm. Pedal Control
211	532 12 01-83	Bearing Nylon
213	532 40 31-19	Knob Control Cruise
214	532 41 68-63	Pedal Forward
215	532 40 17-23	Pedal Reverse
220	532 19 89-08	Reflector RH
221	532 40 31-87	Retainer Spring Clip Handle
222	879 21 20-10	Washer 21/32 x 1-1/4 x 10 Ga.
284	532 41 76-93	Nut U-Chnl. 1/4-20
286	872 01 05-20	Bolt 5/16-18 x 2.50
306	876 02 04 16	Pin Cotter 1/8 x 1

NOTE: All component dimensions given in U.S. inches
1 inch = 25.4 mm

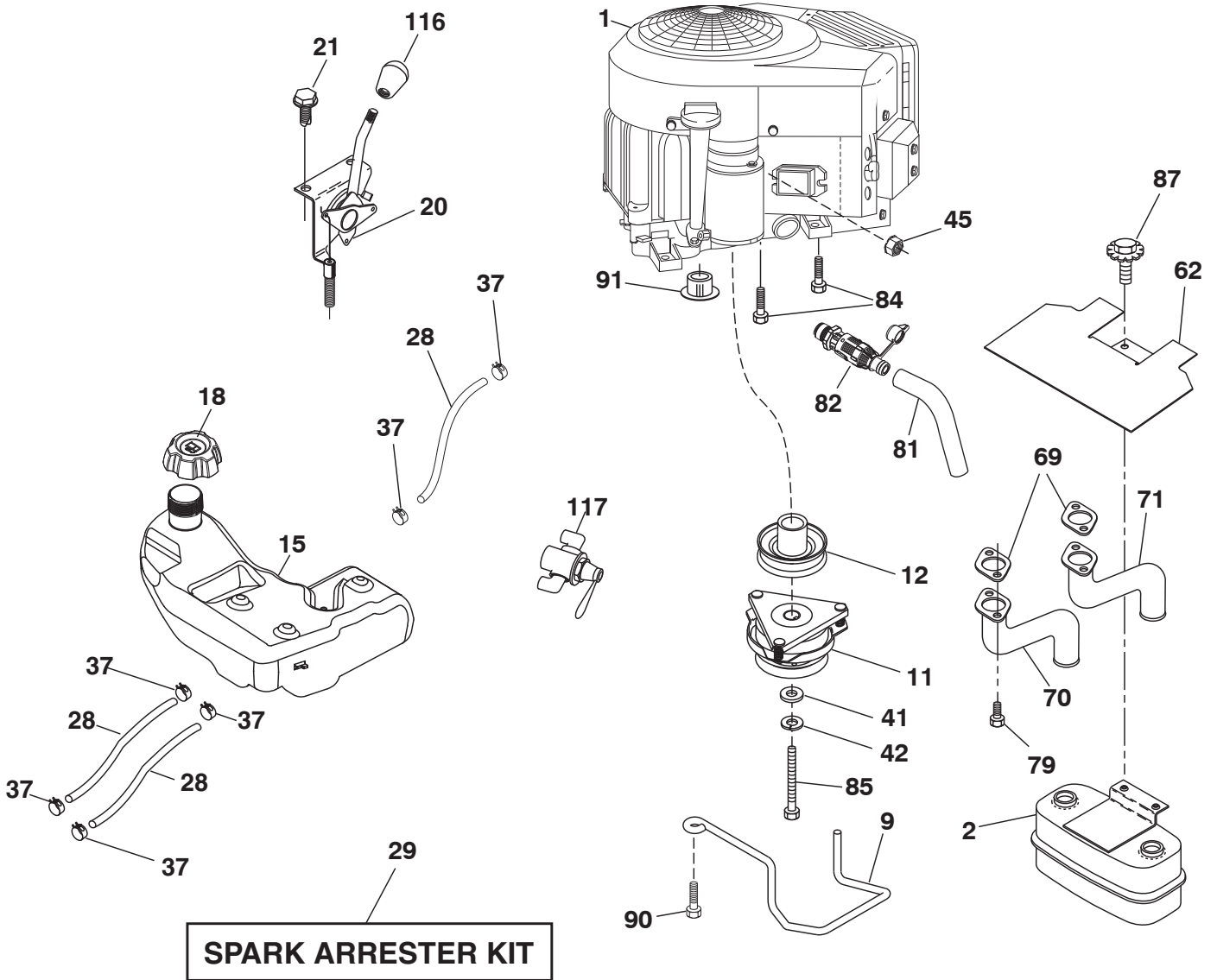

engine-tex_bs-2cyl_79

**TRACTOR - - MODEL NO. GTH3052TF (96041026501), PRODUCT NO. 960 41 02-65
ENGINE 24**

KEY NO.	PART NO.	DESCRIPTION
1	— — — — —	Engine B&S Model No. 44M877-5598-G5 (448325) (Order parts from engine manufacturer.)
2	532 14 97-23	Muffler
9	532 40 86-67	Keeper Asm. Belt Engine
11	532 17 93-35	Clutch Electric
12	532 19 43-43	Pulley Engine
15	532 42 28-04	Tank Fuel
18	532 43 96-45	Cap Asm
20	532 42 43-40	Control Throttle
21	532 41 63-58	Screw #10 x 0.750 BOS Thread
28	532 14 21-58	Fuel Line
29	532 13 71-80	Spark Arrester Kit
37	532 12 34-87	Clamp Hose
41	532 12 61-97	Washer 1-1/2 OD x 15/32 ID x .250
42	810 04 07-00	Washer Lock 7/16
45	873 51 04-00	Nut Keps Hex 1/4-20 unc
62	532 43 40-17	Shield Heat Muffler
69	532 16 53-91	Gasket
70	581 88 11-01	Tube Exhaust LH
71	581 88 10-01	Tube Exhaust RH
79	532 18 39-06	Screw Socket HD 5/16-18 x 1
81	532 14 84-56	Tube Drain Oil
82	532 42 82-87	Valve Oil Drain
84	817 06 06-20	Screw 3/8-16 x 1-1/4
85	532 17 99-53	Bolt 7/16-20 x 3.75 Gr. 5
87	532 19 82-39	Bolt 5/16-18 unc x 1 w/Sems
90	817 00 06-16	Screw 3/8-16 x 1
91	532 18 74-95	Bushing
116	539 13 26-24	Knob Shift
117	532 42 08-28	Valve Fuel Reserve

NOTE: All component dimensions given in U.S. inches
1 inch = 25.4 mm

Engine Power Rating Information

The gross power rating for individual gas engine models is labeled in accordance with SAE (Society of Automotive Engineers) code J1940 (Small Engine Power & Torque Rating Procedure), and rating performance has been obtained and corrected in accordance with SAE J1995 (Revision 2002-05). Torque values are derived at 3060 RPM; horsepower values are derived at 3600 RPM. Actual gross engine power will be lower and is affected by, among other things, ambient operating conditions and engine-to-engine variability. Given both the wide array of products on which engines are placed and the variety of environmental issues applicable to operating the equipment, the gas engine will not develop the rated gross power when used in a given piece of power equipment (actual “on-site” or net power). This difference is due to a variety of factors including, but not limited to, accessories (air cleaner, exhaust, charging, cooling, carburetor, fuel pump, etc.), application limitations, ambient operating conditions (temperature, humidity, altitude), and engine-to-engine variability. Due to manufacturing and capacity limitations, Briggs & Stratton may substitute an engine of higher rated power for this Series engine.

TRACTOR - - MODEL NO. GTH3052TF (96041026501), PRODUCT NO. 960 41 02-65
STEERING ASSEMBLY **41**

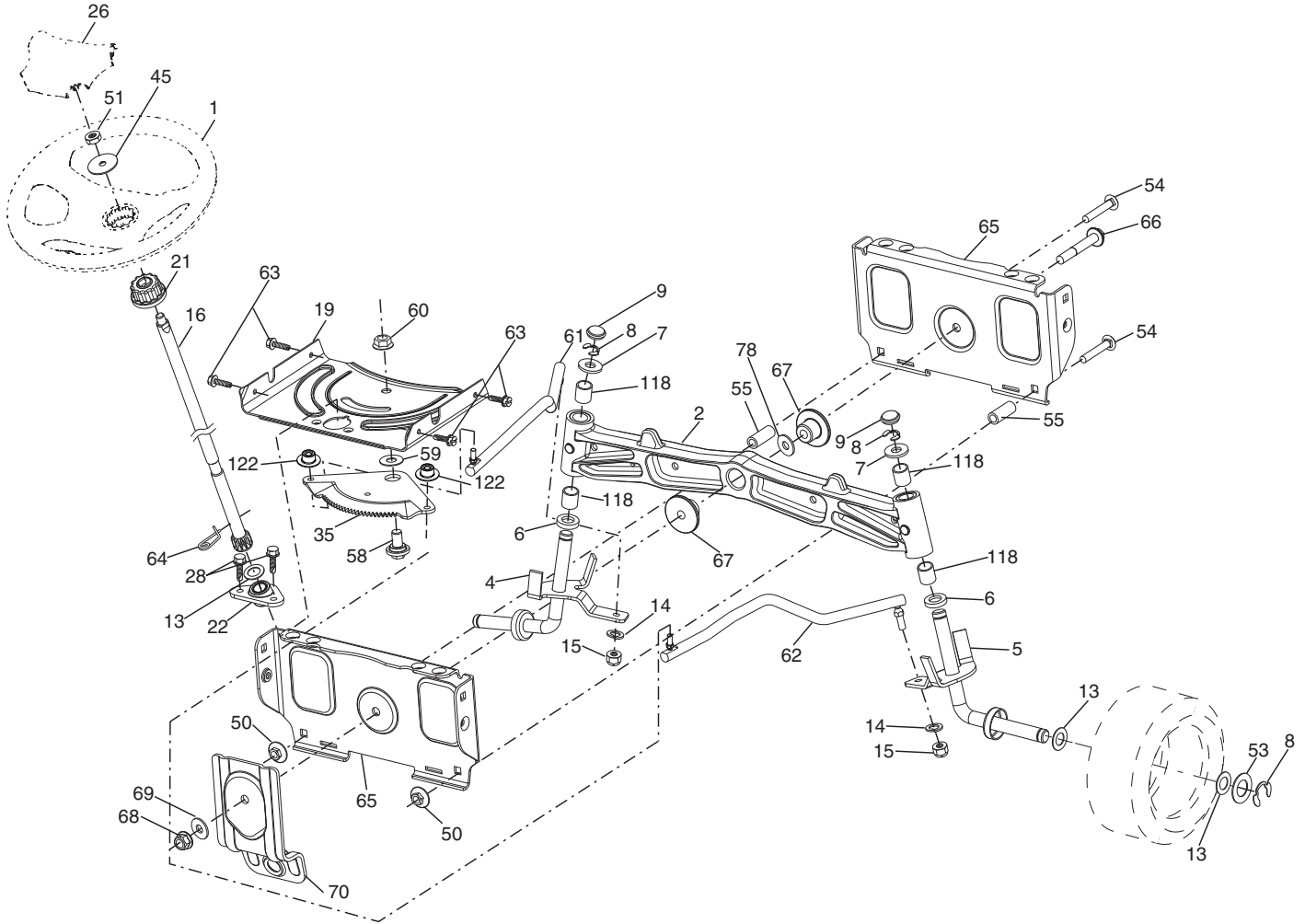

Steering-tex_LEGND2_38_r2

**TRACTOR - - MODEL NO. GTH3052TF (96041026501), PRODUCT NO. 960 41 02-65
STEERING ASSEMBLY **41****

KEY NO.	PART NO.	DESCRIPTION
1	532 43 97-40	Wheel, Steering
2	532 41 35-91	Axle Asm., Front
4	532 40 30-89	Spindle Asm., LH
5	532 40 30-90	Spindle Asm., RH
6	532 12 49-31	Bearing, Race Thrust Harden
7	532 12 17-48	Washer 25/32 x 1-5/8 x 16 Ga.
8	812 00 00-29	Ring, Klip #T5304-75
9	532 12 12-32	Cap, Spindle
13	532 12 17-49	Washer 25/32 x 1-1/4 x 16 Ga.
14	810 04 06-00	Washer, Lock Hvy Hlcl Spr 3/8
15	873 54 06-00	Nut, Crown Lock 3/8-24 unf
16	532 19 47-46	Shaft Steering
19	532 19 47-29	Plate Steering
21	532 18 67-37	Adapter, Wheel Steering
22	532 42 05-37	Strg. Supt. Lower
26	532 43 97-43	Insert, Wheel Steering
28	817 00 06-12	Screw 3/8-16 x 3/4
35	532 19 47-32	Gear, Sector Plate
45	819 18 38-12	Washer 9/16 x 2-3/8 x 12 Ga.
50	873 90 06-00	Nut Lock Flg. 3/8-16 unc
51	873 94 08-00	Nut Hex Jam Toplock 1/2-20 unf
53	532 18 89-67	Washer Hardened .793 x 1.637 x .060
54	874 76 06-36	Bolt Hex Hs 3/8-16 unc x 2-1/4
55	532 41 47-36	Spacer Brace Axle
58	532 19 47-47	Bolt Shoulder Sector Pivot CFM
59	532 19 47-48	Washer Thrust Sector Steering
60	873 97 10-00	Nut Flange Lock 5/8-11
61	532 19 47-40	Draglink, LH
62	532 19 47-41	Draglink, RH
63	817 00 05-12	Screw 5/16-18 x 3/4
64	532 19 98-49	Retainer Clip Spring Steering
65	532 19 47-34	Brace Axle Front
66	871 02 07-48	Bolt Hex Fghd 7/16-14 x 3 Serr
67	532 19 47-37	Bushing PM Front Axle
68	873 90 07-00	Nut Lock Flange 7/16-14 Gr. 5
69	532 19 91-62	Washer 1.5 x .505 x .118
70	532 19 61-97	Bracket Deck Susp. Front
78	532 05 70-79	Washing Thrust
118	532 40 60-13	Bushing
122	532 44 49-62	Cap Gear Sector

NOTE: All component dimensions given in U.S. inches
1 inch = 25.4 mm

TRACTOR - - MODEL NO. GTH3052TF (96041026501), PRODUCT NO. 960 41 02-65
MOWER DECK **44**

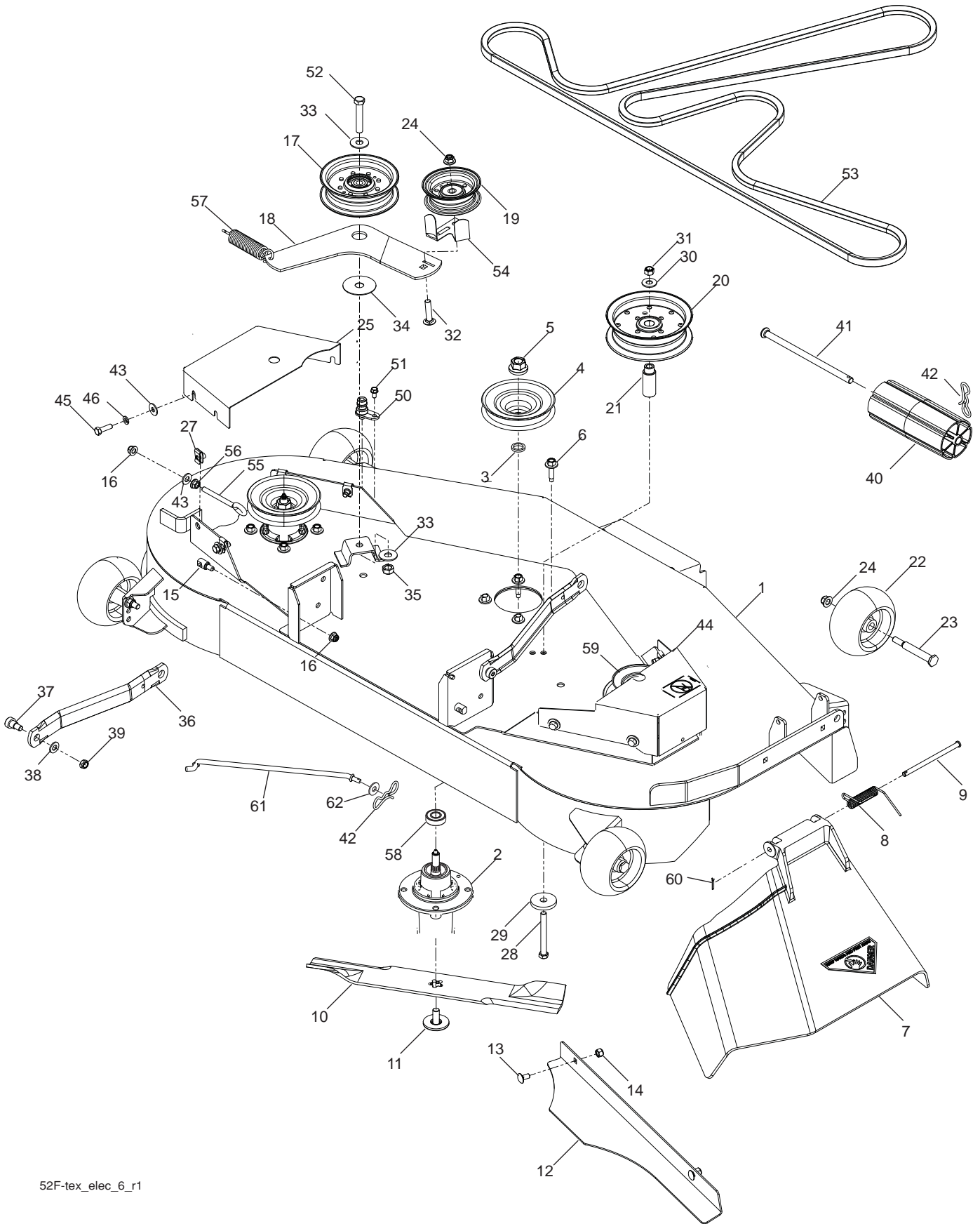

**TRACTOR - - MODEL NO. GTH3052TF (96041026501), PRODUCT NO. 960 41 02-65
MOWER DECK 44**

KEY NO.	PART NO.	DESCRIPTION	KEY NO.	PART NO.	DESCRIPTION
1	574 80 44-02	Deck Asm. 52"	35	873 90 07-00	Nut, 7/16-14 Gr. 5
2	539 11 21-70	Housing Assembly	36	532 19 51-85	Arm, Susp., Rear
3	532 18 76-90	Washer-Spacer	37	539 11 36-21	Sb 3/8-16 x 3/8 Skt Hd
4	532 17 43-75	Pulley, Mandrel	38	819 13 13-16	Washer, 13/32 x 13/16 x 16 Ga.
5	532 40 02-34	Nut Flange Lock Top	39	539 20 02-82	Nut, 3/8-16 Hex Jam Nyloc
6	532 17 39-84	Screw Thd Roll	40	532 17 60-66	Roller, Nose
7	539 11 07-33	Discharge Chute, 52"	41	532 17 91-27	Rod, Roller, Nose, Narrow
8	539 11 07-35	Spring - Torsion	42	532 19 42-08	Pin Cotter 5/16 Bow Tie Lock
9	539 11 07-36	Pin, Clevis 5/16 x 5.19	43	819 12 14-14	Washer, 3/8 x 7/8 x 14 Ga.
10	574 87 08-01	Blade, 16-1/4"	44	575 96 73-02	Shield, Belt RH
11	532 19 30-03	Bolt, Washer Asm. 7/16-20 unf	45	874 78 05-16	Bolt Fin Hex 5/16-18 unc x 1.00
12	574 87 50-01	Confinement Plate	46	810 03 05-00	Washer 5/16
13	872 11 05-05	Bolt Carr 5/16-18 x 5/8	50	532 41 55-98	Washout Port
14	873 80 05-00	Nut Lock 5/16-18 unc	51	817 49 04-08	Bolt, 1/4-20 x 1/2
15	532 19 51-61	Stud, Fasten w/ Anti- Rotate	52	874 78 07-40	Bolt 7/16-14 x 2-1/2
16	539 11 28-99	Nut 5/16-18 Hex Flange Nyloc	53	574 84 56-03	Belt, Deck
17	532 19 61-04	Pulley, Idler Spec. Hub	54	532 14 10-43	Guard, Idler
18	574 84 18-01	Arm, Idler, Blk	55	539 11 55-74	Eyebolt 5/16 x 3-1/2
19	532 17 79-68	Pulley, Idler	56	539 99 05-85	Nut 5/16-18 Hex Whizlk
20	539 13 27-28	Pulley, Idler	57	539 10 68-50	Spring
21	575 22 45-01	Idler Bushing	58	532 11 04-85	Ball Bearing
22	532 13 39-57	Wheel, Gauge	59	575 35 29-01	Pulley
23	532 19 34-06	Bolt, Shoulder	60	532 16 94-84	Clip Retainer
24	521 99 65-01	Nut 3/8-16 Hex Flg Nyloc	61	532 40 03-37	Rod Anti-Sway
25	575 22 47-02	Shield, Belt LH	62	819 13 13-12	Washer 13/32 x 13/16 x 12 Ga.
27	539 10 47-63	Retainer 5/16c U Type	--	532 44 53-61	Mower Deck Complete
28	539 10 82-71	Hcs 3/8-16 x 3-1/2 Gr 5			
29	539 10 65-04	Heavy Washer			
30	819 14 16-14	Washer, 3/8 Flat			
31	539 97 69-79	Nut 3/8-16 Hex Nyloc			
32	539 99 09-23	Rhsnb 3/8-16 x 1-3/4 Gr 5			
33	539 10 48-64	Washer, 7/16 Flat			
34	532 17 85-15	Washer, Flat Hardened			

NOTE: All component dimensions given in U.S. inches
1 inch = 25.4 mm

**TRACTOR - - MODEL NO. GTH3052TF (96041026501), PRODUCT NO. 960 41 02-65
MOWER LIFT **45****

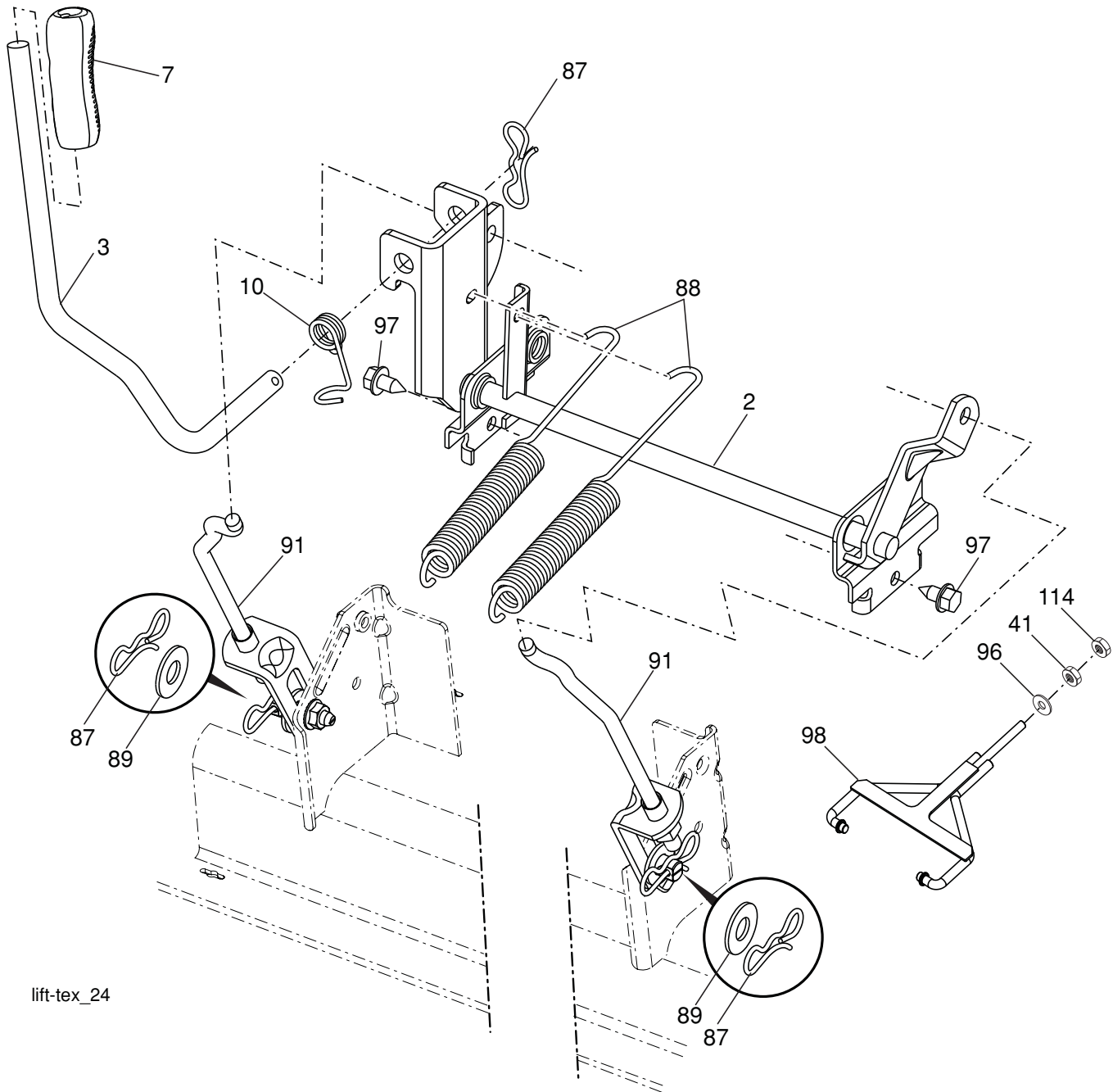

lift-tex_24

KEY NO.	PART NO.	DESCRIPTION
2	532 42 20-27	Shaft Asm., Lift
3	532 19 52-30	Lever Asm., Lift RH
7	532 41 15-55	Grip, Lever
10	532 19 63-14	Spring Torsion
41	532 17 59-94	Nut Lift Link
87	532 19 42-09	Pin Cotter 7/16 Bow Tie Lock
88	532 19 53-04	Spring Lift Assist
89	819 19 19-12	Washer Clear Zinc

KEY NO.	PART NO.	DESCRIPTION
91	532 40 34-07	Link Lift Susp Mower Rear
96	532 19 52-63	Bushing Spherical
97	817 00 06-12	Screw 3/8-16 x .75
98	574 82 25-01	Weldment Front Deck Suspension
114	873 36 07-00	Nut Jam 7/16-20

NOTE: All component dimensions given in U.S. inches
1 inch = 25.4 mm

**TRACTOR - - MODEL NO. GTH3052TF (96041026501), PRODUCT NO. 960 41 02-65
SEAT ASSEMBLY 42**

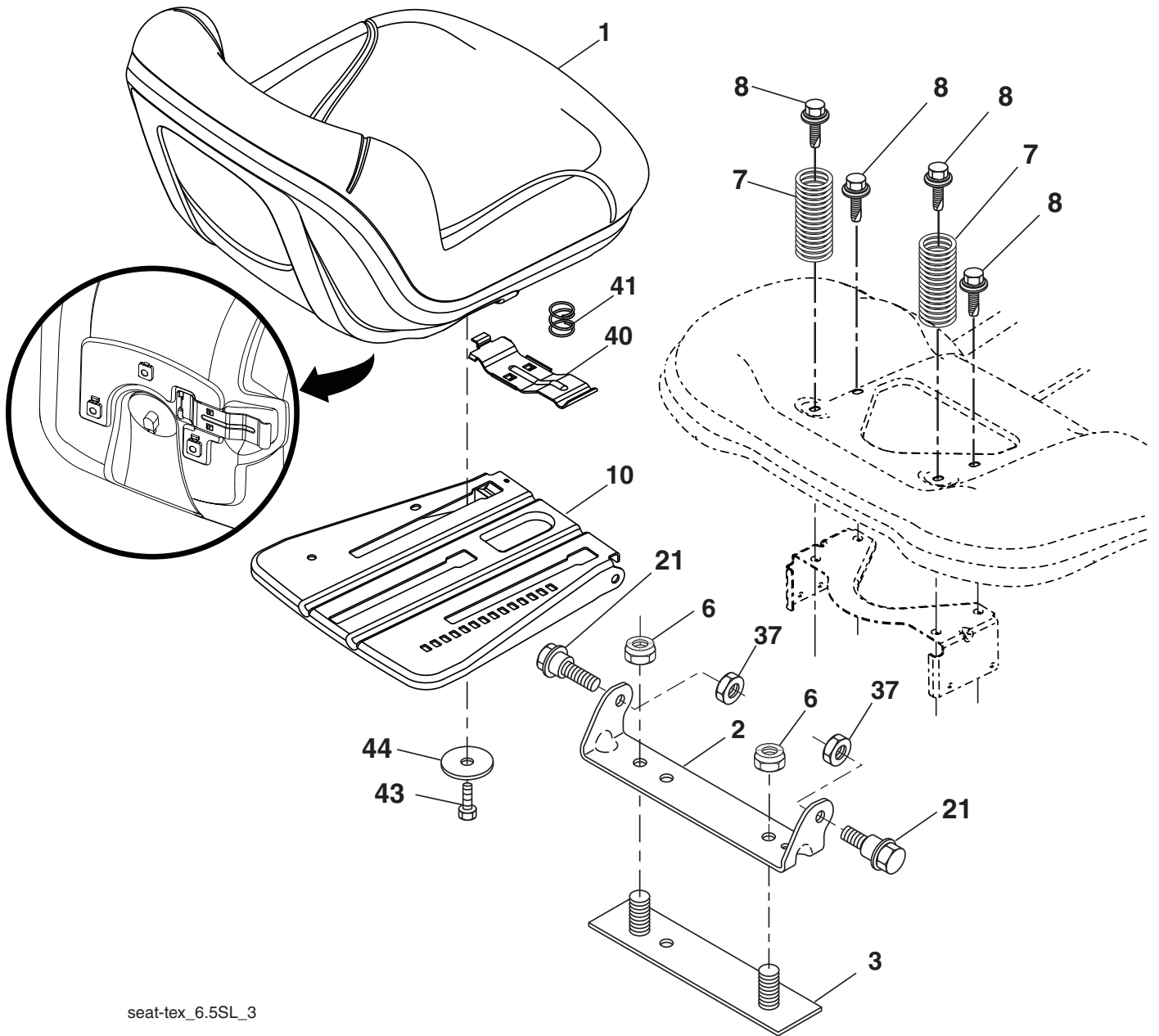

seat-tex_6.5SL_3

KEY NO.	PART NO.	DESCRIPTION
1	532 44 32-63	Seat
2	532 18 01-66	Bracket Pivot Fender
3	532 14 06-75	Strap, Asm Fender
6	873 80 06-00	Nut, Lock w/Ins. 3/8-16 unc
7	532 12 41-81	Spring, Seat Cprsn
8	532 17 18-77	Bolt 5/16-18 unc x 3/4 w/Sems
10	532 19 69-77	Pan, Seat
21	532 17 18-52	Bolt, Shoulder 5/16-18

KEY NO.	PART NO.	DESCRIPTION
37	873 80 05-00	Nut, Lock 5/16-18 unc
40	532 19 76-61	Handle Slide Seat
41	532 19 82-00	Spring Latch Seat
43	874 76 06-12	Bolt Fin Hex 3/8-16 unc x 3/4
44	819 13 38-12	Washer 13/32 x 2-3/8 x 12 Ga.

NOTE: All component dimensions given in U.S. inches
1 inch = 25.4 mm