

# ILLUSTRATED PARTS LIST

**MFG. ID NO. 96041031000**

**CUSTOMER CATALOG NO. GTH264T**

**PRODUCT NO. 960 41 03-10**

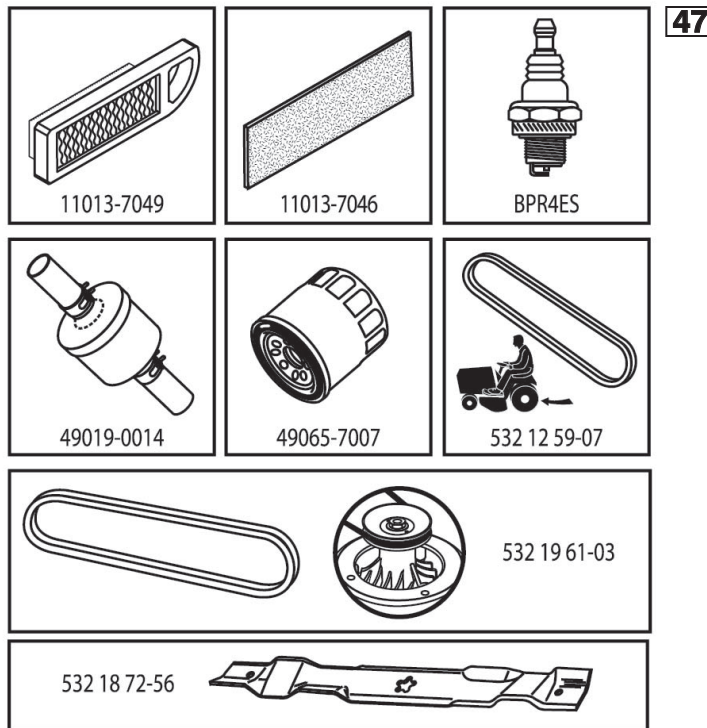

581563701

**TRACTOR - - MODEL NO. GTH264T (96041031000), PRODUCT NO. 960 41 03-10  
DECALS 27**

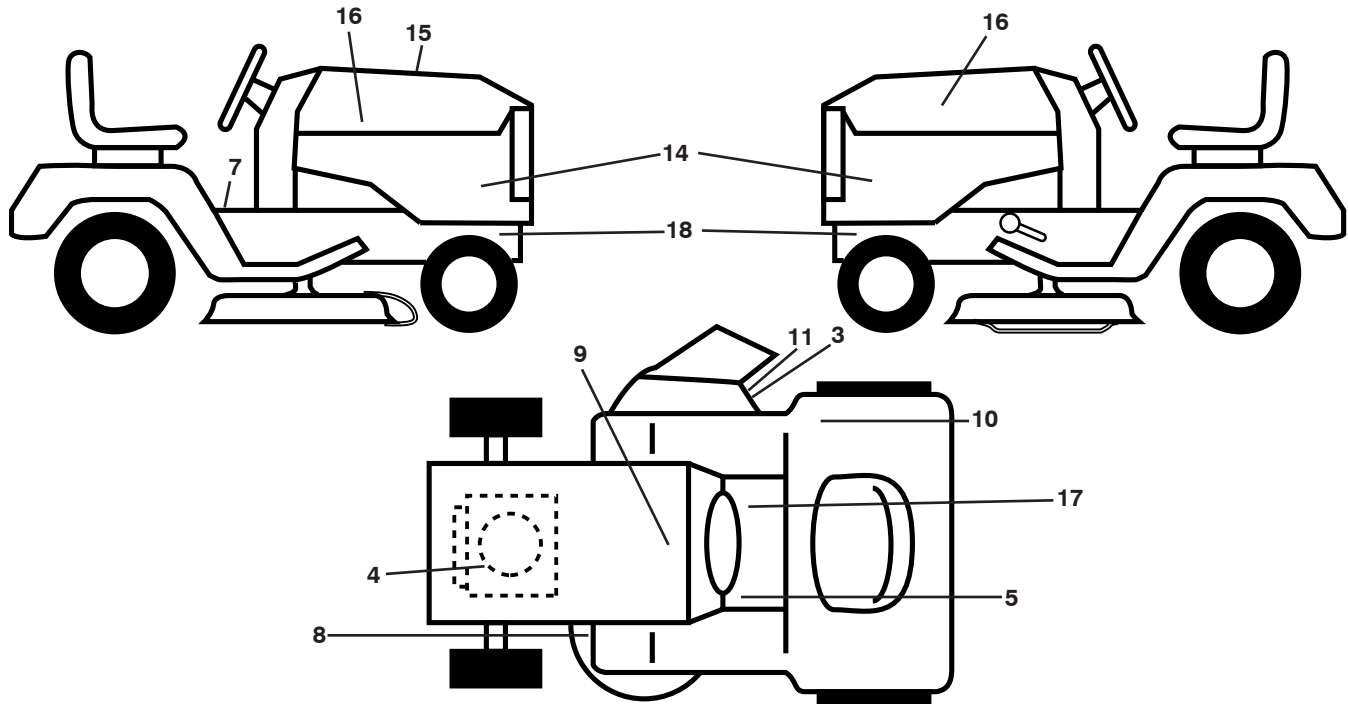

KEY NO.	PART NO.	DESCRIPTION
3	581 57 92-01	Decal, Warning
4	581 57 97-01	Decal, Engine Warning Symbols
5	581 72 40-01	Decal, Brake Pedal
7	581 57 81-01	Decal, Warning Symbols
8	581 58 00-02	Decal, Mower Sch.
9	532 14 50-05	Decal, Battery Dan./Poi.
10	581 57 82-01	Decal, Fender DB/CE
11	581 57 91-01	Decal, Hand/Foot Sym.
14	532 44 65-46	Decal, Panel Side
15	581 56 37-01	Decal, Replacement Parts
16	581 62 73-01	Decal, Hood Logo

KEY NO.	PART NO.	DESCRIPTION
17	581 57 80-01	Decal, Park Brake
18	581 57 96-01	Decal, Chassis Hot Muffler
--	581 72 46-01	Decal, Drawbar Load Limit
--	581 72 48-01	Decal, Bypass
--	532 43 98-82	Pad, Footrest, LH
--	532 43 98-81	Pad, Footrest, RH
--	115 53 33-20	Manual, Operator's (Euro)
--	115 53 41-10	Manual, Operator's (Scan)
--	115 53 42-50	Manual, Operator's (E-Bloc)
--	115 53 43-40	Manual, Operator's (Baltic)

**WHEELS AND TIRES**

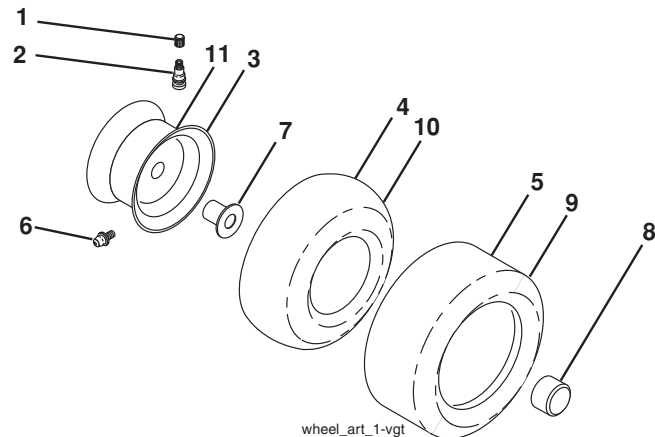

KEY NO.	PART NO.	DESCRIPTION
1	532 05 91-92	Cap, Valve, Tire
2	532 06 51-39	Stem, Valve
3	532 18 18-39	Rim Assembly, Front
4	532 00 81-34	Tube, Front (Service Item Only)
5	532 10 62-30	Tire, Front
6	532 12 49-57	Fitting, Grease (Front Wheel Only)
7	532 12 49-59	Bearing, Flange (Front Wheel Only)
8	532 17 50-39	Cap, Axle
9	532 10 55-88	Tire, Rear
10	532 00 71-54	Tube, Rear (Service Item Only)
11	532 14 45-10	Rim Assembly, Rear
--	532 14 43-34	Sealant, Tire (10 oz. Tube)

**NOTE:** All component dimensions given in U.S. inches  
1 inch = 25.4 mm



**TRACTOR - - MODEL NO. GTH264T (96041031000), PRODUCT NO. 960 41 03-10  
ELECTRICAL 32**

<b>KEY NO.</b>	<b>PART NO.</b>	<b>DESCRIPTION</b>
1	532 16 34-65	Battery
2	874 76 04-12	Bolt Hex Hd. 1/4-20 unc x 3/4
8	532 18 64-91	Battery Box
16	532 17 61-38	Switch Interlock
21	532 40 02-52	Harness Socket Light
22	532 00 41-52	Bulb, Light # 1156
24	532 40 02-53	Cable Battery
25	532 41 28-95	Cable Start Red
26	532 17 51-58	Fuse
27	873 51 04 00	Nut Keps Hex 1/4-20 unc
28	532 14 54-91	Cable Ground 21" Blk. 6 Ga.
29	532 40 15-45	Switch Seat
30	532 19 33-50	Switch Ign.
33	532 41 19-35	Key/Chain
34	532 11 07-12	Switch Light/Reset
40	581 02 27-01	Harness Dash/Ign.
41	817 72 04-08	Screw 1/4-20 x 1/2
42	532 13 15-63	Cover Terminal
43	532 19 25-07	Solenoid
46	532 40 17-63	Gauge Hourmeter
50	532 17 46-51	Switch PTO
55	817 06 05-12	Screw 5/16-18 x 3/4
71	532 19 42-76	Harness Chassis/Ing.
79	532 17 52-42	Socket Asm. Bulb
90	532 43 53-95	Cover Terminal Battery
91	532 19 02-70	Strap Battery
99	817 67 04-12	Screw Hex Wsh. Thdrol. 1/4-20 x 3/4
100	819 09 14-16	Washer 9/32 x 7/8 x 16 Ga.
102	532 40 44-54	Harness Pigtail Tex Ros Tuff Torq.
105	532 40 75-68	Switch Reverse
142	532 44 80-57	Harness Charge Port

**NOTE:** All component dimensions given in U.S. inches  
1 inch = 25.4 mm

TRACTOR - - MODEL NO. GTH264T (96041031000), PRODUCT NO. 960 41 03-10  
CHASSIS AND ENCLOSURES **39**

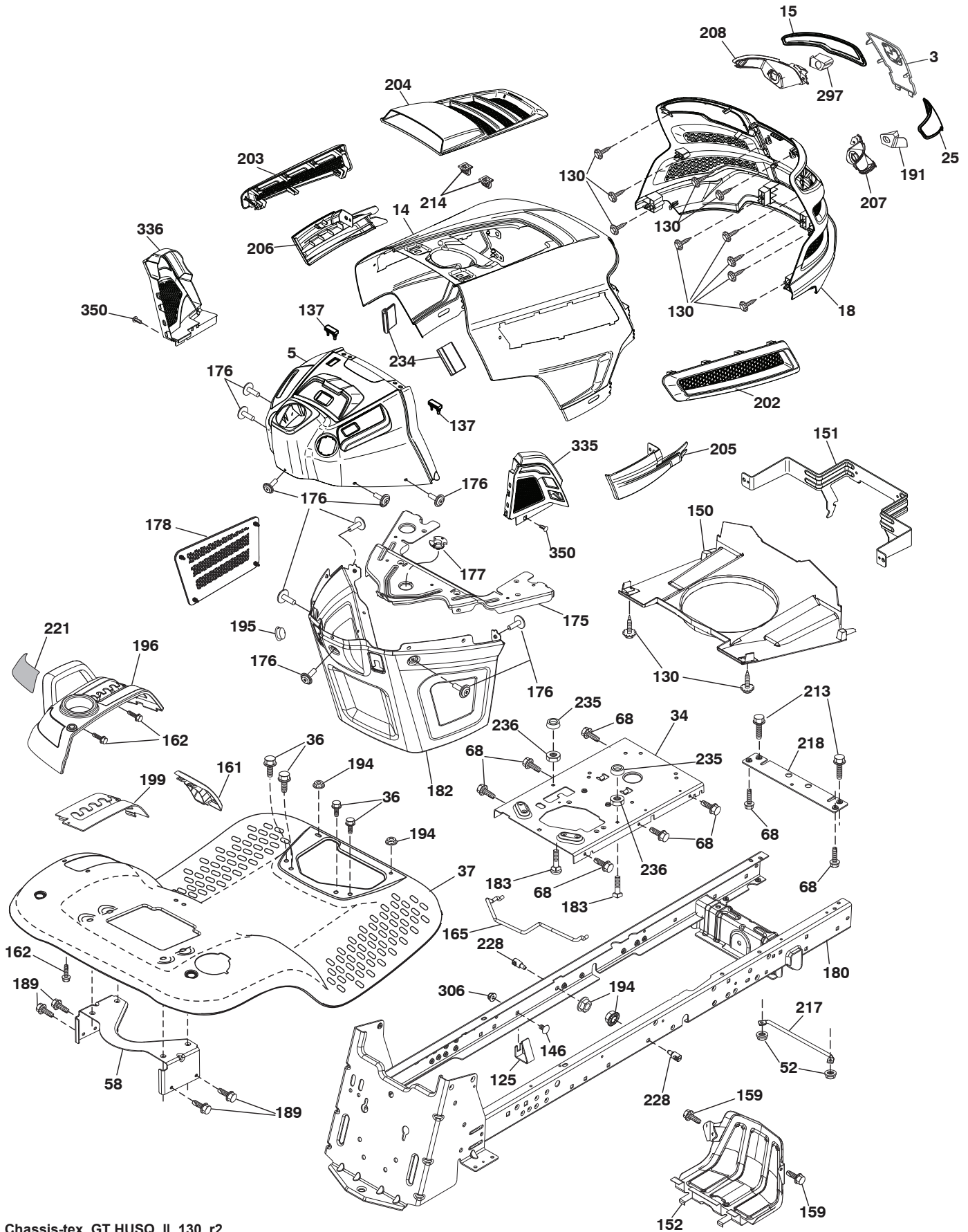

Chassis-tex\_GT HUSQ\_II\_130\_r2

**TRACTOR - - MODEL NO. GTH264T (96041031000), PRODUCT NO. 960 41 03-10  
CHASSIS AND ENCLOSURES 39**

KEY NO.	PART NO.	DESCRIPTION	KEY NO.	PART NO.	DESCRIPTION
3	532 43 97-52	Applique Sub Asm.	194	873 90 05-00	Nut Lock Hex Flange 5/16-18
5	532 43 74-84	Dash	195	532 40 41-37	Plug 12 V Adapter
14	532 44 11-77	Hood	196	532 43 97-16	Console Asm. Deck Lift
15	532 43 97-33	Lens LH	199	532 19 82-59	Plate Deck Lift
18	532 44 06-53	Grille	202	532 43 97-28	Vent Side Hood RH
25	532 44 33-85	Lens RH	203	532 43 97-27	Vent Side Hood LH
34	580 91 08-01	Plate Engine	204	532 43 57-14	Vent Asm. Hood Top
36	817 06 05-12	Screw 5/16-18 x 3/4	205	532 43 97-30	Skirt Hood Side RH
37	532 44 12-08	Fender	206	532 43 97-29	Skirt Hood Side LH
52	873 68 05-00	Nut Crownlock 5/16-18	207	532 43 97-34	Bezel RH
58	532 19 43-14	Bracket Fender	208	532 43 97-35	Bezel LH
68	817 49 05-08	Screw 5/16-18 x 1/2	213	874 76 05-12	Bolt Hex Hd. 5/16-18 unc x 3/4
125	581 68 48-01	Clip Fuel Line	214	532 19 91-45	Clip Retainer
130	532 41 63-58	Screw #10 x 0.750	217	532 40 91-67	Rod Pivot
137	532 40 75 90	Bumper Dash	218	532 19 63-95	Hood Stop
146	581 85 79-01	Bolt	221	532 19 89-09	Reflector LH
150	532 43 97-74	Duct Heat Hood	228	532 19 51-61	Stud Fastener
151	532 43 66-70	Pivot Bracket	234	532 40 47 42	Bumper Hood
152	532 43 98-70	Shield Browning/Debris	235	532 40 61 29	Spacer Fender
159	817 00 06-12	Screw Hexwsh Thdr 3/8-16 x 3/4	236	873 93 05-00	Nut 5/16-18 unc
161	532 43 99-29	Console Fuel Window	297	532 43 74 56	Insert Reflective LH
162	532 14 24-32	Screw Hex Wsh. Hi-Lo 1/4 x 1/2	306	873 90 06-00	Nut Lock
165	532 19 68-26	Bracket Support Tank	335	532 44 82-04	Lower Dash Cover RH
175	532 19 63-04	Crossmember	336	532 44 53-09	Lower Dash Cover LH
176	532 40 07-76	Screw #10-24 x 5/8	350	532 44 51-43	Clip X-mas Tree
177	532 19 52-27	Bushing Steering	- -	532 43 18-82	Kit Bumper
178	532 19 97-82	Cargo Asm. Net			
180	532 19 54-77	Chassis			
182	532 40 68-59	Dash Lower			
183	874 52 05-20	Bolt 5/16-18 unc x 1-1/4			
189	817 00 05-12	Screw 5/16-18 x 3/4			
191	532 43 74-55	Insert Reflective RH			

**NOTE:** All component dimensions given in U.S. inches  
1 inch = 25.4 mm

TRACTOR - - MODEL NO. GTH264T (96041031000), PRODUCT NO. 960 41 03-10  
DRIVE **40**

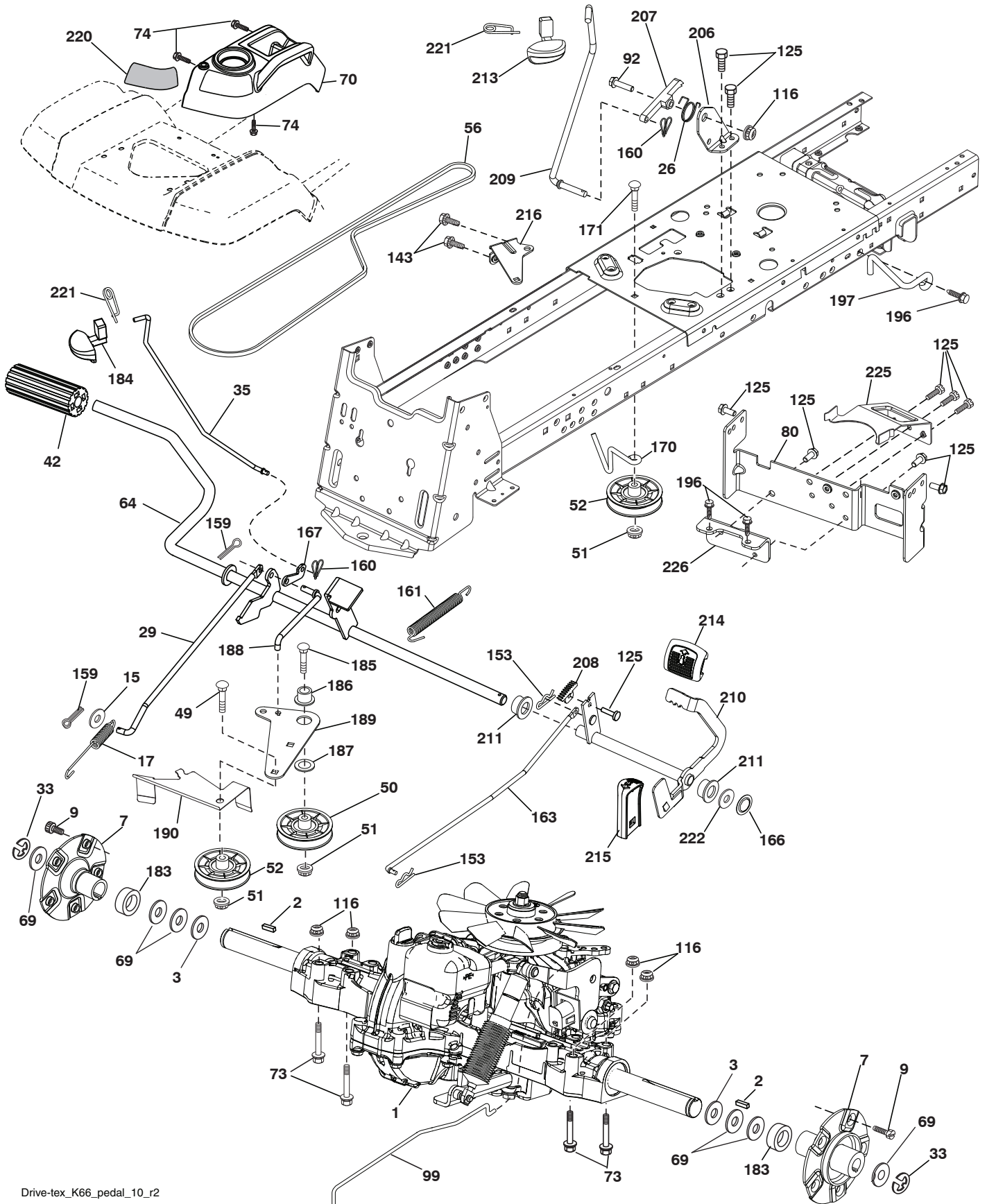

Drive-tex\_K66\_pedal\_10\_r2

**TRACTOR - - MODEL NO. GTH264T (96041031000), PRODUCT NO. 960 41 03-10  
DRIVE 40**

KEY NO.	PART NO.	DESCRIPTION	KEY NO.	PART NO.	DESCRIPTION
1	-----	Transaxle, TuffTorq K66Y(426118) (Order parts from transaxle manufacturer.)	163	532 40 72-46	Rod Pedal Control
2	532 00 70-70	Key	166	532 42 91-64	Nut Push .625
3	532 00 75-63	Hardened Washer	167	532 40 52-57	Latch Brake Parking
7	532 19 98-37	Hub Asm. Wheel	170	532 19 43-22	Keeper Belt Centerspan
9	532 14 00-80	Bolt Hub Wheel	171	872 11 06-16	Bolt
15	819 13 13-16	Washer 13/32 x 13/16 x 16 Ga.	183	532 19 73-57	Spacer Axle
17	532 40 10-72	Spring, Brake	184	532 44 14-55	Handle Parking Brake
26	532 19 96-79	Spring Return Cruise	185	872 11 06-22	Bolt
29	532 40 72-45	Rod, Brake	186	532 19 43-21	Spacer Retainer
33	812 00 00-53	Ring E	187	819 13 32-10	Washer
35	583 86 45-01	Rod, Brake, Park	188	532 19 43-23	Link Clutch Ground Drive
42	532 12 48-72	Cover, Foot Pedal	189	532 19 43-17	Bellcrank Ground Drive
49	872 11 06-14	Bolt	190	532 19 43-18	Keeper Bellcrank Ground Drive
50	532 19 43-27	Pulley Idler Flat	196	817 00 06-16	Screw 3/8-16 x 1
51	873 90 06-00	Lock Nut 3/8-16	197	532 19 97-69	Bracket Clutch Anti-Rotation
52	532 19 43-26	Idler V-Groove	206	532 19 78-67	Bracket Mount Latch Cruise
56	532 12 59-07	V-Belt, Drive	207	532 19 78-68	Latch Control Cruise
64	532 19 78-65	Shaft Asm. Pedal Brake Control	208	532 19 78-69	Gear Sector Control Cruise
69	532 12 38-00	Washer 1 1/32 x 1 5/8 x 16 Ga.	209	532 19 95-92	Rod Control Cruise
70	532 43 96-61	Console Asm.	210	532 19 78-60	Rocker Asm Cruise
73	874 49 05-44	Bolt Hex Flghd 5/16-18 Gr. 5	211	532 12 01-83	Bearing Nylon
74	532 14 24-32	Screw Hx Wsh Hi-Lo 1/4 x 1/2 unc	213	532 40 31-19	Handle Parking Brake
80	532 40 71-82	Strap Torque	214	532 42 12-63	Pedal Forward Pad
92	874 76 05-20	Bolt Fin Hex 5/16-18 unc x 1.25	215	532 40 17-23	Pedal Reverse Pad
99	532 41 57-44	Rod Bypass	216	532 19 61-31	Bracket Pulley Idler
116	873 90 05-00	Nut Lock Hex Flange 5/16-18	220	532 19 89-08	Reflector RH
125	817 00 05-12	Screw 5/16-18 x 3/4	221	532 40 31-87	Retainer Spring Clip Handle
143	817 49 05-08	Screw 5/16-18 x 1/2	222	879 21 20-10	Washer 21/32 x 1-1/4 10 Ga.
153	532 12 47-88	Retainer Spring	225	532 40 73-11	Keeper Belt Trans.
159	876 02 04-12	Pin Cotter 1/8 x 3/4	226	532 40 71-09	Bracket Mount Torque
160	532 16 94-84	Retainer Clip			
161	532 10 57-09	Spring, Return, Clutch			

**NOTE:** All component dimensions given in U.S. inches  
1 inch = 25.4 mm



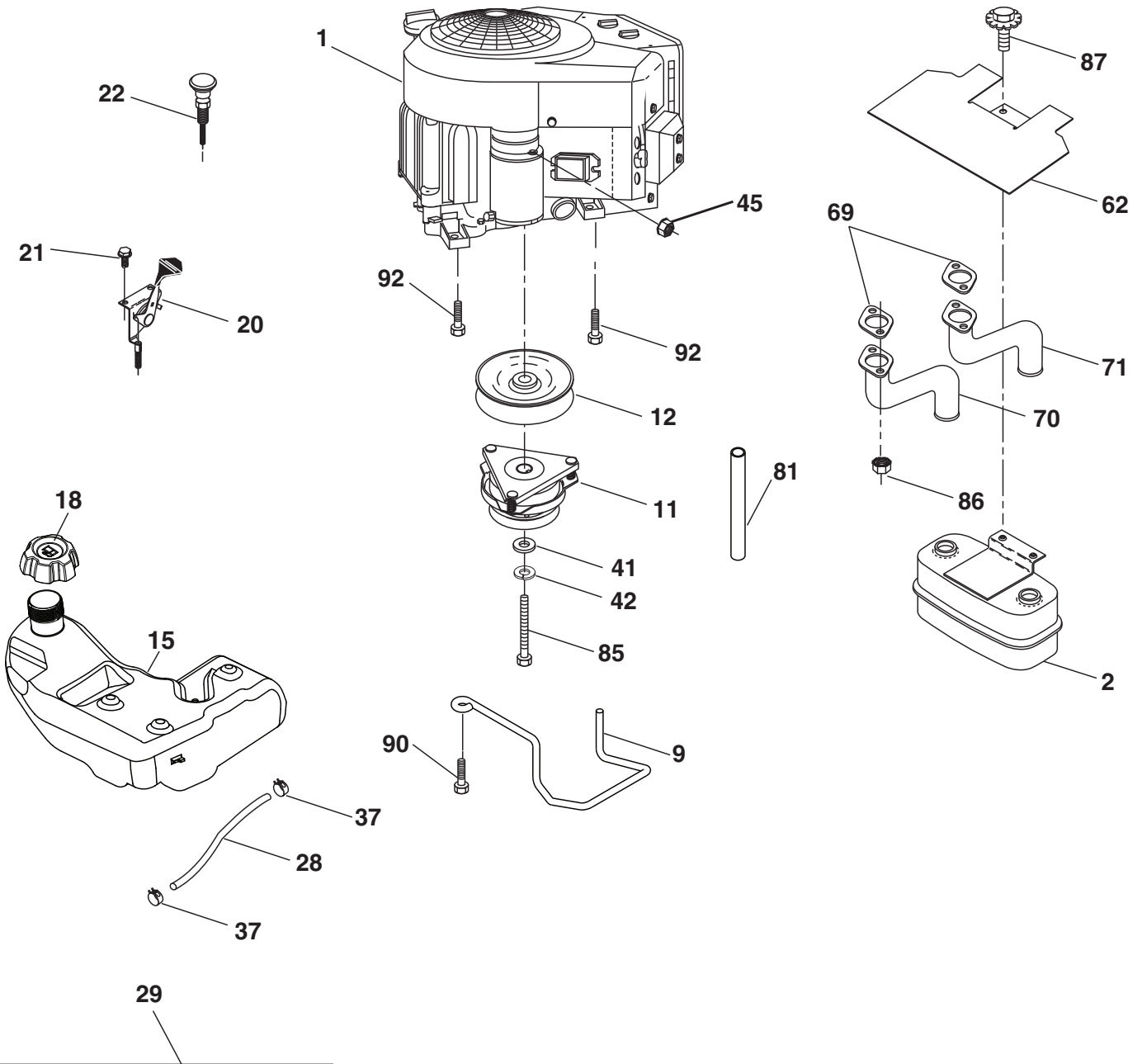

**SPARK ARRESTER KIT**

engine-tex\_Kawa-2cyl\_8

**TRACTOR - - MODEL NO. GTH264T (96041031000), PRODUCT NO. 960 41 03-10  
ENGINE 24**

<b>KEY NO.</b>	<b>PART NO.</b>	<b>DESCRIPTION</b>
1	-----	Kawasaki FS730V-BS50 (445369) (Order parts from engine manufacturer.)
2	532 44 59-62	Muffler
9	532 19 43-20	Keeper Belt Engine
11	532 17 93-35	Clutch Electric
12	532 19 43-43	Pulley Engine
15	532 19 34-99	Tank Fuel 4.0
18	532 43 96-45	Cap Fuel
20	532 41 21-65	Control Throttle
21	532 41 63-58	Screw #10 x 0.750
22	532 18 95-41	Control Choke
28	532 14 21-58	Fuel Line
29	532 13 71-80	Spark Arrester Kit
37	532 12 34-87	Clamp Hose
41	532 12 61-97	Washer 1-1/2 OD x 15/32 ID x .250
42	810 04 07-00	Washer Lock 7/16
45	873 51 04-00	Nut Keps 1/4-20 unc
62	532 43 40-17	Shield Heat Muffler
69	532 17 81-51	Gasket
70	532 42 47-65	Tube Exhaust LH
71	532 42 47-66	Tube Exhaust RH
81	532 14 84-56	Tube Drain Oil Easy
85	532 17 99-53	Bolt Hex 7/16-20 x 3.75 Gr. 5
86	532 18 43-62	Nut
87	532 17 18-77	Bolt 5/16-18 unc x 1 w/Sems.
90	817 00 06-16	Screw 3/8-16 x 1
92	817 12 06-16	Screw 3/8-16 x 1

**NOTE:** All component dimensions given in U.S. inches  
1 inch = 25.4 mm

TRACTOR - - MODEL NO. GTH264T (96041031000), PRODUCT NO. 960 41 03-10  
 STEERING ASSEMBLY **41**

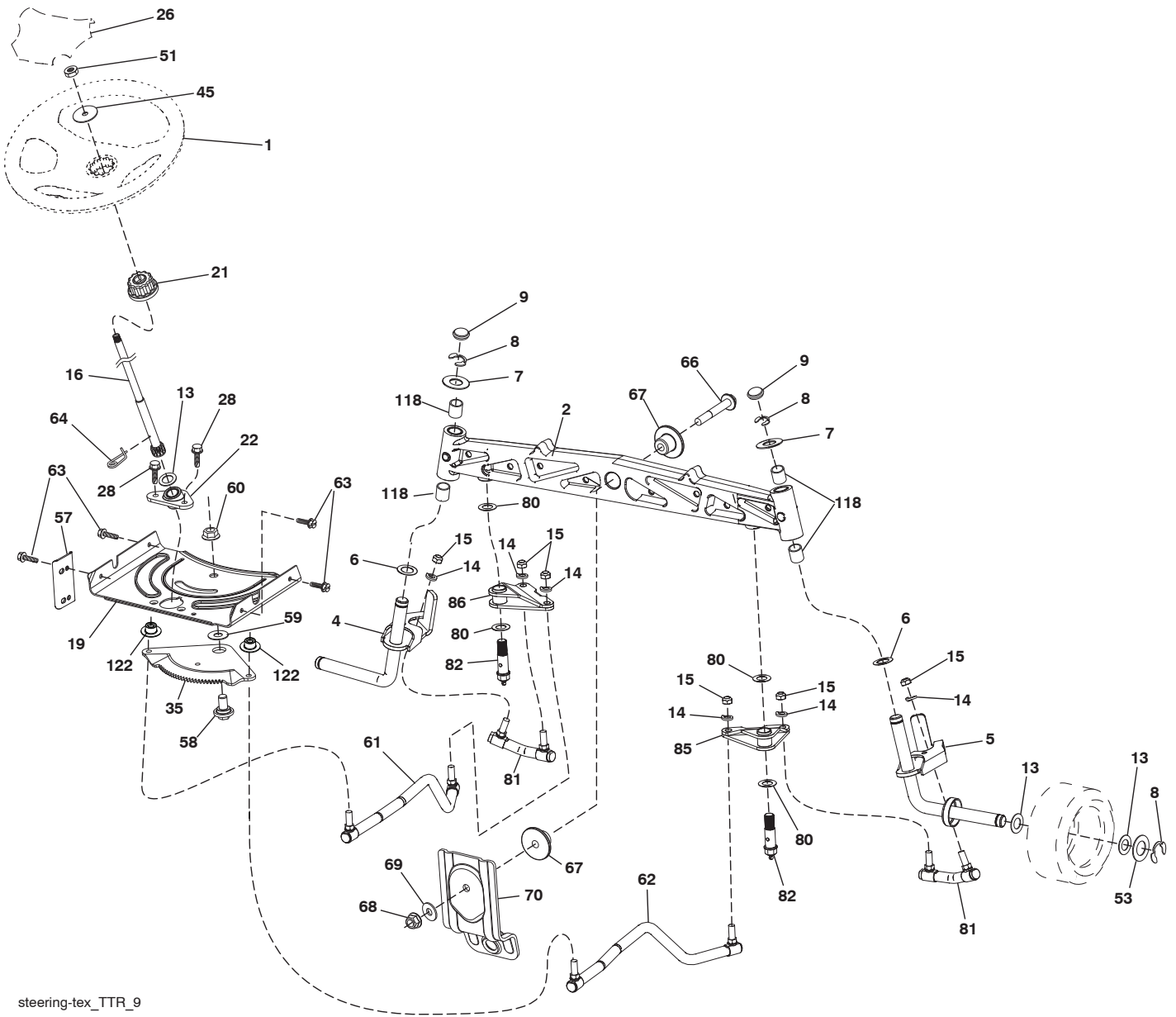

steering-tex\_TTR\_9

**TRACTOR - - MODEL NO. GTH264T (96041031000), PRODUCT NO. 960 41 03-10  
STEERING ASSEMBLY 41**

KEY NO.	PART NO.	DESCRIPTION
1	532 43 97-40	Wheel, Steering Husq SR
2	532 43 68-70	Axle Asm., Front
4	532 43 68-73	Spindle Asm., LH
5	532 43 68-74	Spindle Asm., RH
6	532 12 49-31	Bearing, Race Thrust Harden
7	532 12 17-48	Washer 25/32 x 1-5/8 x 16 Ga.
8	812 00 00-29	Ring, Clip #T5304-75
9	532 12 12-32	Cap, Spindle
13	532 12 17-49	Washer 25/32 x 1-1/4 x 16 Ga.
14	810 04 06-00	Washer, Lock Hvy. Hlcl. Spr. 3/8
15	873 54 06-00	Nut, Crown Lock 3/8-24 unf
16	532 44 42-12	Shaft Steering
19	532 19 47-29	Plate Steering
21	532 43 77-47	Adapter, Wheel Steering
22	532 19 48-45	Bushing
26	532 43 97-43	Insert, Wheel Steering Husq SR
28	817 00 06-12	Screw 3/8-16 x 3/4
35	532 44 07-70	Gear, Sector Plate
45	819 18 38-12	Washer 9/16 x 2-3/8 x 12 Ga.
51	873 94 08-00	Nut Hex Jam Toplock 1/2-20 unf
53	532 18 89-67	WasherHardened.793x1.637x.060
57	532 19 72-46	Bracket Upstop
58	532 19 47-47	Bolt Shoulder Sector Pivot CFM
59	532 19 47-48	Washer Thrust Sector Steering
60	873 97 10-00	Nut Flange Lock 5/8-11
61	532 43 68-84	Draglink, LH
62	532 43 68-85	Draglink, RH
63	817 00 05-12	Screw 5/16-18 x 3/4
64	532 19 98-49	Retainer Clip Spring Steering
66	871 02 07-48	Bolt Hex Fghd. 7/16-14 x 3 Serr.
67	532 19 47-37	Bushing PM Front Axle
68	873 90 07-00	Nut Lock Flange 7/16-14 Gr. 5
69	532 19 91-62	Washer 1.5 x .505 x .118
70	532 19 61-97	Bracket Deck Susp. Front
80	532 00 13-70	Washer Thrust
81	532 43 68-87	Subasm Link Cross RH
82	532 43 68-77	Pivot Bolt
85	532 44 18-73	Pivot RH NZTR
86	532 44 18-72	Pivot LH NZTR
118	532 40 60-13	Bushing
122	532 44 49-62	Cap Gear Sector Tex

**NOTE:** All component dimensions given in U.S. inches  
1 inch = 25.4 mm

TRACTOR - - MODEL NO. GTH264T (96041031000), PRODUCT NO. 960 41 03-10  
MOWER DECK **44**

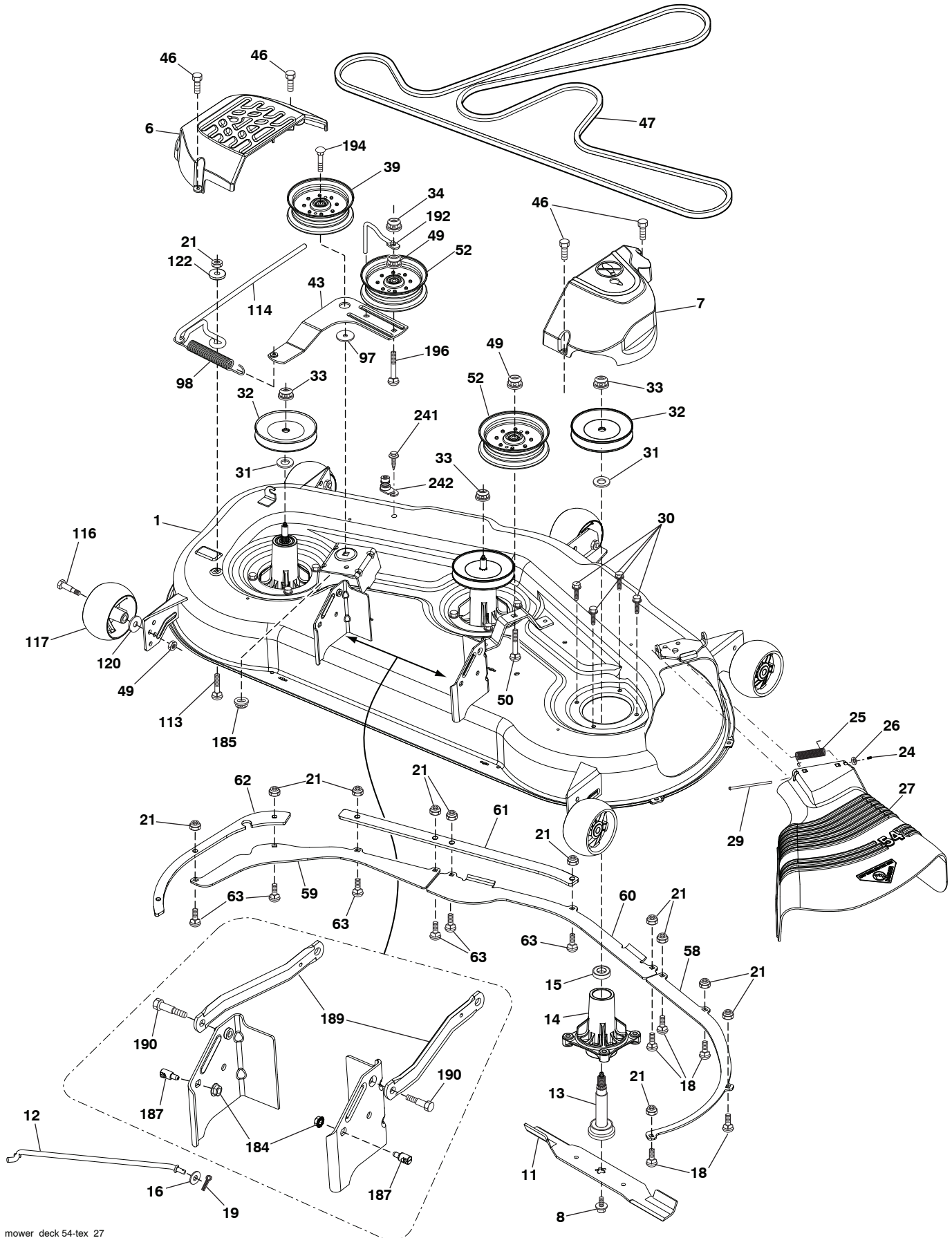

mower\_deck 54-tex\_27

**TRACTOR - - MODEL NO. GTH264T (96041031000), PRODUCT NO. 960 41 03-10  
MOWER DECK 44**

KEY PART NO. NO.	DESCRIPTION	KEY PART NO. NO.	DESCRIPTION		
1	532 44 15-47	Deck Weldment Mower	61	581 96 81-03	Plate Reinforcement Front
6	532 19 60-66	Cover Mandrel LH	62	581 96 82-03	Plate Reinforcement Side
7	532 19 71-81	Cover Mandrel RH	63	872 11 05-10	Bolt Carr 5/16 - 18 x 1-1/4 Gr. 5
8	532 19 30-03	Bolt 7/16 Asm. Blade	97	532 17 85-15	Washer Hardened
11	532 18 72-56	Blade	98	532 19 61-05	Spring Drive
12	532 40 03-37	Rod Anti-Sway	113	872 11 05-08	Bolt Rdhd. Sqnk. 5/16-18 x 3/4
13	532 18 72-91	Shaft Asm. w/Lower Bearing	114	532 18 75-56	Rod Tension Relief
14	532 18 72-81	Housing, Mandrel	116	532 19 34-06	Bolt, Shoulder
15	532 11 04-85	Bearing, Ball, Mandrel	117	532 17 48-73	Gauge Wheel
16	819 13 13-12	Washer 13/32 x 13/16 x 12 Ga.	120	819 13 20-12	Washer 13/32 x 1-1/4 x 12 Ga.
18	872 14 05-05	Bolt RDHD Sqnk. 5/16-18	122	532 18 75-57	Bushing Tension Relief
19	532 19 42-08	Pin Cotter 5/16 Bow Tie Lock	184	873 90 05-00	Nut Lock Hex Flange
21	873 68 05-00	Nut, Crownlock 5/16-18 unc	185	873 90 07-00	Nut Lock Flange 7/16-14 Gr. 5
24	532 10 53-04	Cap Sleeve	187	532 19 51-61	Stud Fastener w/"D" Anti-Rotation
25	532 17 81-02	Spring, Torsion	189	532 19 51-85	Arm Susp. Mower Rear
26	532 11 04-52	Nut, Push	190	532 19 65-39	Bolt Shoulder
27	532 18 89-38	Deflector Shield	192	532 19 84-68	Keeper Belt Idler
29	532 13 14-91	Rod, Hinge	194	874 49 07-36	Bolt Hex Washer Head
30	532 17 39-84	Screw, Thdrol. Washer Head	196	872 14 06-20	Bolt 3/8-16 x 2-1/2 Gr. 5
31	532 18 76-90	Washer, Spacer Mower Vented	241	532 15 29-27	Screw TT #10-32.5 3/8 Flange
32	532 15 35-35	Pulley, Mandrel	242	532 41 55-98	Port Washout
33	532 40 02-34	Nut, Flg. Top Lock	--	532 18 72-92	Mandrel Assembly (Includes housing (key #14), shaft assembly (key #13), and bearing (key #15) only - pulley/nut/washer and blade bolt/washers not included)
34	873 68 06-00	Nut Crownlock 3/8-16 unc	--	532 30 50-01	Replacement Mower, Complete
39	532 19 73-80	Pulley, Idler, Stationary LH			
43	532 19 60-65	Arm, Idler			
46	532 13 77-29	Screw Thd Roll 1/4-20 x 5/8			
47	532 19 61-03	Belt Deck Drive			
49	873 90 06-00	Nut, Lock Flg. 3/8-16 unc			
50	872 11 06-16	Bolt Rdhd. Sqnk. 3/8-16 unc x 2			
52	532 19 73-79	Pulley Idler			
58	532 18 73-42	Baffle Right			
59	532 18 73-44	Baffle Left			
60	532 18 76-07	Baffle Center			

**NOTE:** All component dimensions given in U.S. inches  
1 inch = 25.4 mm

TRACTOR - - MODEL NO. GTH264T (96041031000), PRODUCT NO. 960 41 03-10  
 MOWER LIFT **45**

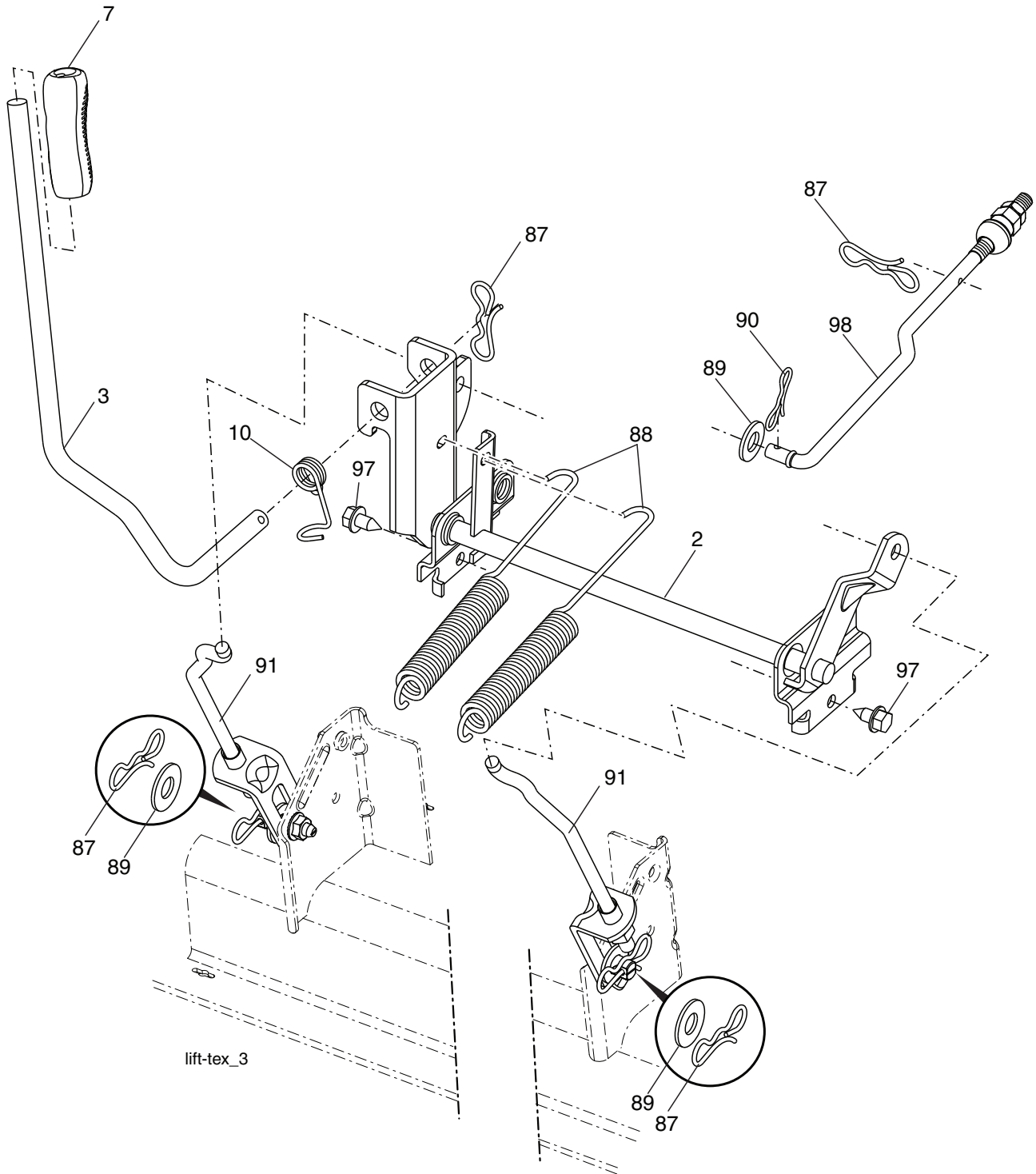

KEY NO.	PART NO.	DESCRIPTION
2	532 42 20-27	Shaft Asm., Lift
3	532 19 52-30	Lever Asm., Lift RH
7	580 96 23-01	Grip, Lever
10	532 19 63-14	Spring Torsion
87	532 19 42-09	Pin Cotter 7/16 Bow Tie Lock
88	532 19 53-04	Spring Lift Assist
89	819 19 19-12	Washer Clear Zinc

KEY NO.	PART NO.	DESCRIPTION
90	532 19 42-08	Pin Cotter 5/16 Bow Tie Lock
91	532 40 34-07	Lift Link Asm. Rear
97	817 00 06-12	Screw 3/8-16 x .75 Smgml. Tap/R.Z
98	532 19 52-64	Link Asm. Susp. Front Mower

**NOTE:** All component dimensions given in U.S. inches  
 1 inch = 25.4 mm

**TRACTOR - - MODEL NO. GTH264T (96041031000), PRODUCT NO. 960 41 03-10  
SEAT ASSEMBLY 42**

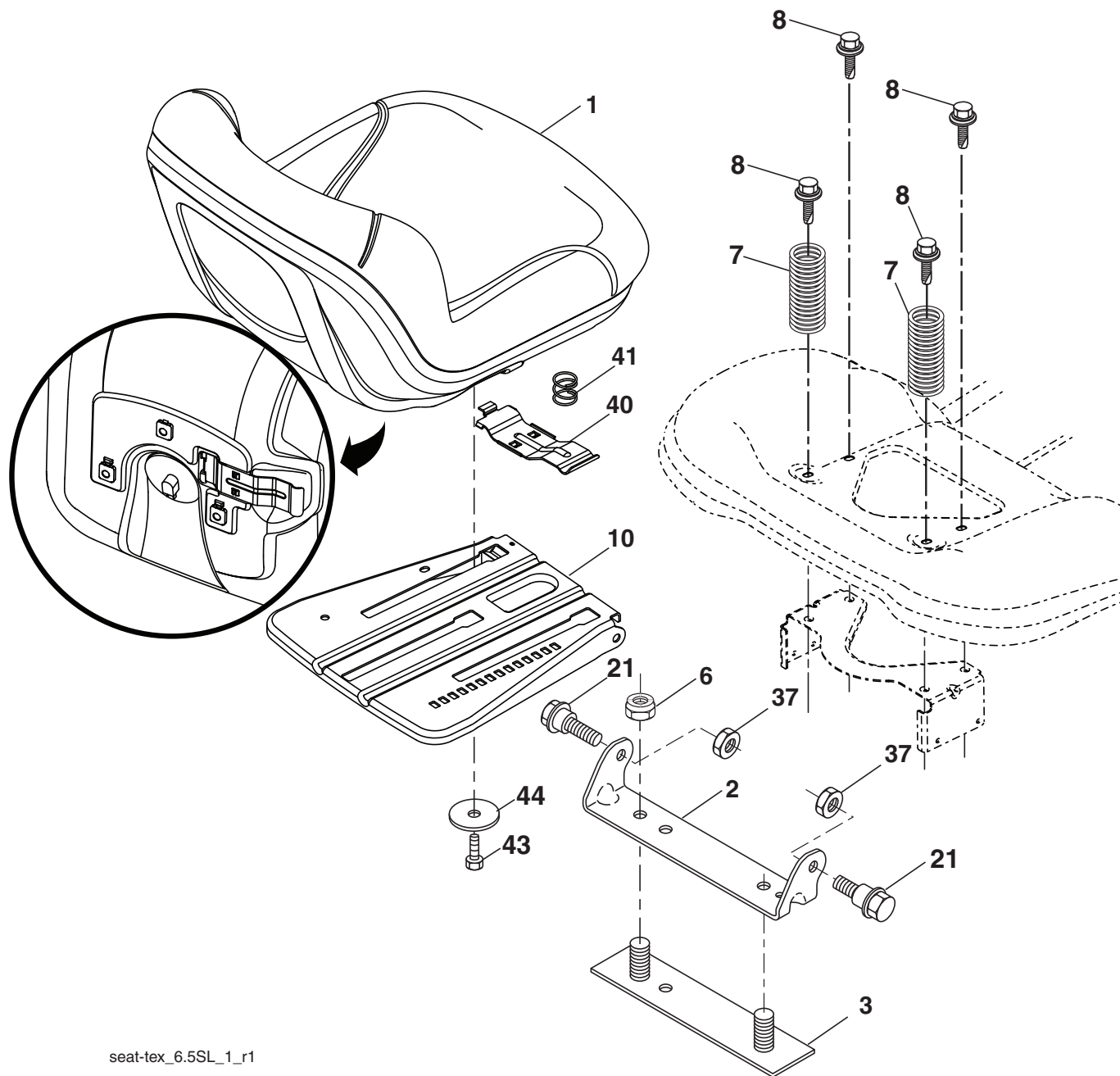

seat-tex\_6.5SL\_1\_r1

KEY NO.	PART NO.	DESCRIPTION
1	532 42 40-73	Seat
2	532 18 01-66	Bracket Pivot Fender
3	532 14 06-75	Strap, Asm. Fender
6	873 80 06-00	Nut, Lock w/Ins. 3/8-16 unc
7	532 12 41-81	Spring, Seat Cprsn.
8	532 17 18-77	Bolt 5/16-18 x 3/4 unc w/Sems.
10	532 19 69-77	Pan, Seat
21	532 17 18-52	Bolt, Shoulder 5/16-18

KEY NO.	PART NO.	DESCRIPTION
37	873 80 05-00	Nut, Lock 5/16-18 unc
40	532 19 76-61	Handle Slide Seat
41	532 19 82-00	Spring Latch Seat
43	874 76 06-12	Bolt 3/8-16 x 3/4
44	819 13 38-12	Washer 13/32 x 2-3/8 x 12 Ga.

**NOTE:** All component dimensions given in U.S. inches  
1 inch = 25.4 mm