



BOSCH

Demolition Hammer

GSH 9 VC | 3 611 C22 080

Table of Content

Spare parts list.....	2
Illustration - Type.....	6

Spare parts list

Item	Part Number	Description
1	1 615 108 165	Motor Housing
2	1 614 220 124	Field 220-240V
4	1 617 200 130	Switch
5	1 614 460 088	Power supply cord CN 4,15m 2 x 1,0mm H07 RN-F
6	1 610 703 053	Grommet Ø9,7-Ø12x89 MM
7	1 601 302 018	Fastening Clamp
9	1 611 11A 17S	Sticker GSH - 9 VC
13	1 610 900 026	groove ball bearing 8x24x8
14	1 610 910 096	Needle-Roller Bearing
15	1 616 610 109	Fan
21	1 610 508 038	Protective Cap
22	1 610 591 051	Protection Sleeve
23	1 610 520 006	Stop Sleeve
24	1 610 500 025	Headed Bush
25	1 612 300 027	Stopping Device
26	1 600 A01 9WL	Indexing Disk
27	1 600 591 05C	Air-Deflector Ring
28	1 614 621 010	Compression Spring
31	1 610 290 129	Damping Ring
35	1 615 806 249	Hammer Pipe
37	1 610 322 018	Control Bushing
38	1 615 190 177	Covering hood
42	1 614 336 090	Brush Holder
43	1 615 500 435	Brush-Cover
44	1 614 621 020	Compression Spring
45	1 610 591 052	Holding-Down-Appliance
48	1 619 990 186	Clutch Sleeve
52	1 610 224 015	Retaining snap ring
54	1 600 A01 9Z4	Spacer Tube
58	1 600 A00 14J	Locking Bush
59	1 615 805 074	Bearing Pedestal
72	1 616 317 090	Eccentric Cog Wheel
80	1 607 233 5R4	Speed governor
94	1 610 290 111	Supporting Disc

Spare parts list

Item	Part Number	Description
95	1 613 120 023	Driving Pin
99	1 600 220 029	Backup ring
110	1 610 190 073	Seal Ring
111	1 610 290 046	Bushing
112	1 613 300 007	Hex Nut
113	1 613 412 001	Tapping Screw B 4,8x68 MM
115	1 610 300 086	Bushing
117	1 610 913 023	Needle-Roller Assembly
119	1 610 910 081	Needle-Roller Bearing
120	1 610 190 080	Spacer Tube
122	1 610 290 128	Spacer Ring
125	1 613 435 040	Torx Oval-Head Screw
126	2 603 490 023	Torx Oval-Head Screw 4x20
129	1 610 300 080	Bushing
138	1 611 015 064	Sealing Frame
142	1 610 290 112	Rotary shaft lip seal
143	1 614 601 072	Retaining ring
144	1 610 103 025	Supporting Disc
151	1 610 210 222	O-Ring
152	1 614 601 073	Retaining ring
153	2 916 540 017	Retaining ring DIN 7993 A 30
154	2 916 660 027	Spring retaining ring DIN 472 62x2 MM
155	1 614 601 074	Retaining ring
157	1 610 210 103	O-Ring 33,0x2,0 MM
158	1 610 210 224	O-Ring
160	1 610 210 246	O-Ring
161	1 610 210 227	Damping Ring
162	1 600 210 080	O-Ring
165	1 610 290 125	Seal Ring
166	1 613 200 020	Cylindrical Roller
167	1 610 290 12A	Rotary shaft lip seal
168	1 610 206 027	Packing Washer
171	1 613 414 026	Torx socket button screw
172	1 613 435 041	Torx Oval-Head Screw
175	2 603 490 021	Torx Oval-Head Screw 4x12

Demolition Hammer | GSH 9 VC | 3 611 C22 080

Spare parts list

Item	Part Number	Description
189	1 615 133 038	Handle
190	1 615 500 438	Handle Cover
192	1 614 611 028	Rocker Foot
194	1 610 099 018	Screw Plate
195	1 610 099 019	Screw Plate
196	1 610 026 004	Damping rubber
197	1 616 232 000	Leaf Spring
204	1 615 102 162	Rear Housing Section
206	1 612 386 006	Holding strip
803	1 614 010 267	Armature 230V
804	1 610 190 027	Stop Disc
808	1 601 11A 3H5	Nameplate
810	1 617 000 A50	Carbon-Brush Set
820	1 618 597 102	Toolholder
821	1 610 508 058	Plain bearing
840	1 607 000 C38	Impact Mechanism Housing
841	1 617 000 A4R	Striker Pin
849	1 617 000 A31	Control Fork
853	1 610 231 004	Guide Bushing
856	1 617 000 A32	Hammer Piston
857	1 617 000 A33	Striker
858	1 616 317 620	Cylindrical Gear
872	1 617 000 A35	Eccentric
873	1 617 000 A4S	Housing Cover
891	1 612 099 005	Rocker Arm
895	1 613 120 024	Diaphragm
897	1 610 415 005	Bellows
898	1 610 415 004	Bellows
899	1 600 A00 4E6	Service package
84	1 602 025 081	Auxiliary Handle
85	1 600 A00 8BL	Clamping Piece
86	2 911 021 267	Hex Screw
88	1 619 P16 922	Star Knob
661	1 615 430 010	Grease Tube 30 ML
691	1 615 438 51A	Carrying Case

Spare parts list

Item	Part Number	Description	
883	1 613 490 019	Hex Screw	
884	1 602 025 08T	Auxiliary Handle	
885	1 602 025 08J	Auxiliary Handle	
887	1 600 A01 BH0	Clamping Band	

Illustration - Type - E

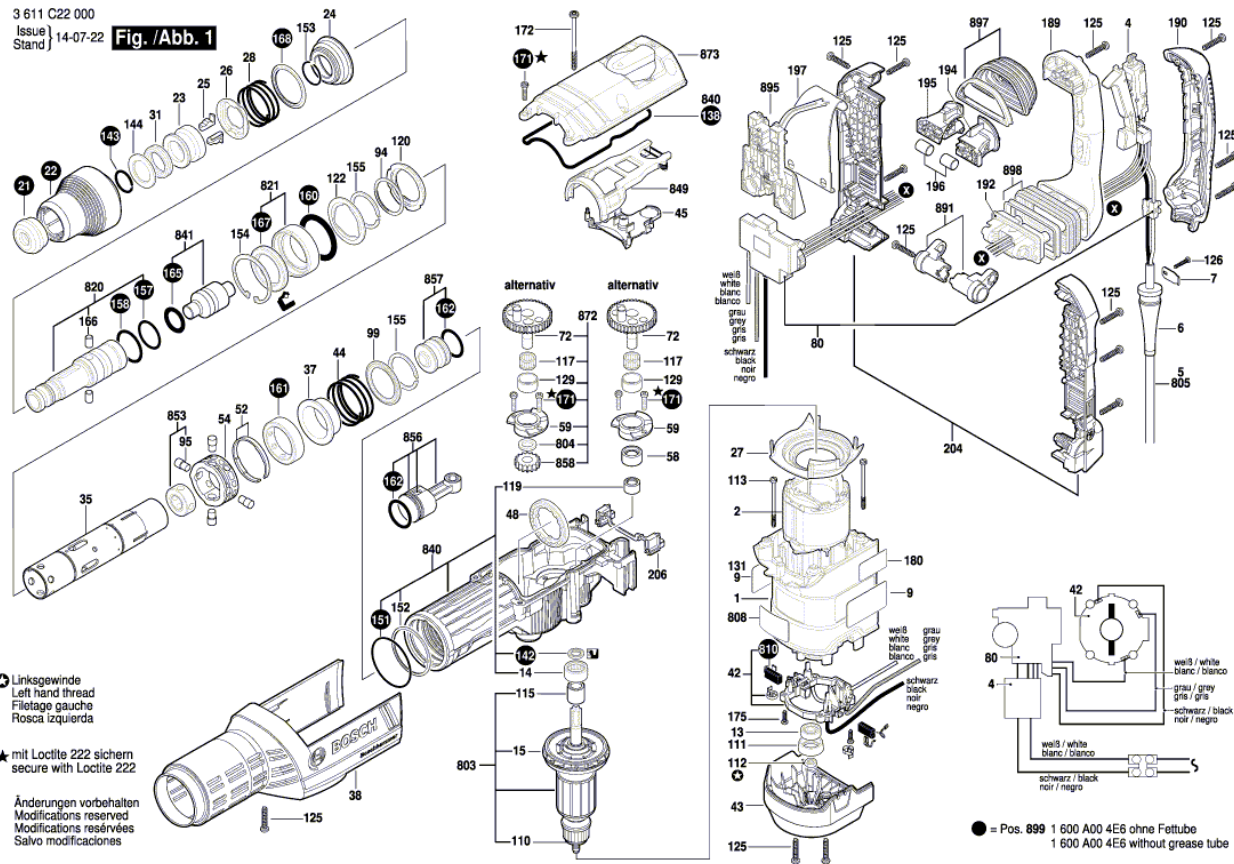
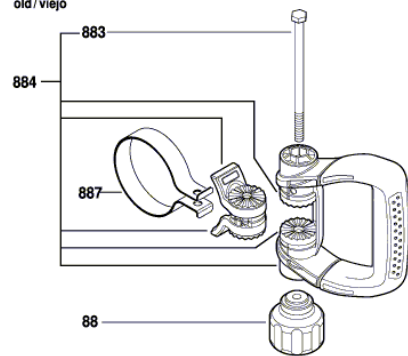

Illustration - Type - E

3 611 C22 000
Issue | 17-03-29
Stand | **Fig./Abb. 2**

alt/ancien
old/viejo



neu/nouveau
new/nuevo

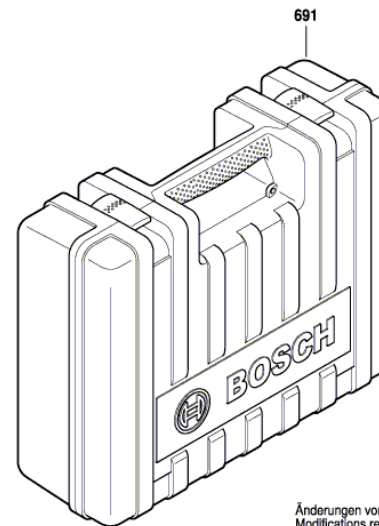
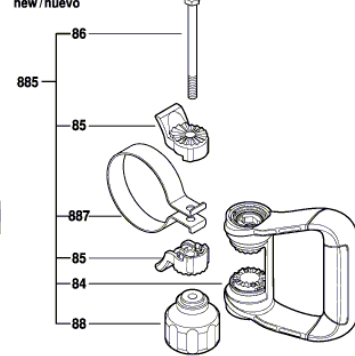

Änderungen vorbehalten
Modifications reserved
Modificaciones reservadas
Salvo modificaciones