

ELECTRIC TOOL PARTS LIST

■ DISC GRINDER
Model G 10SS

2007 · 5 · 18
(E1)

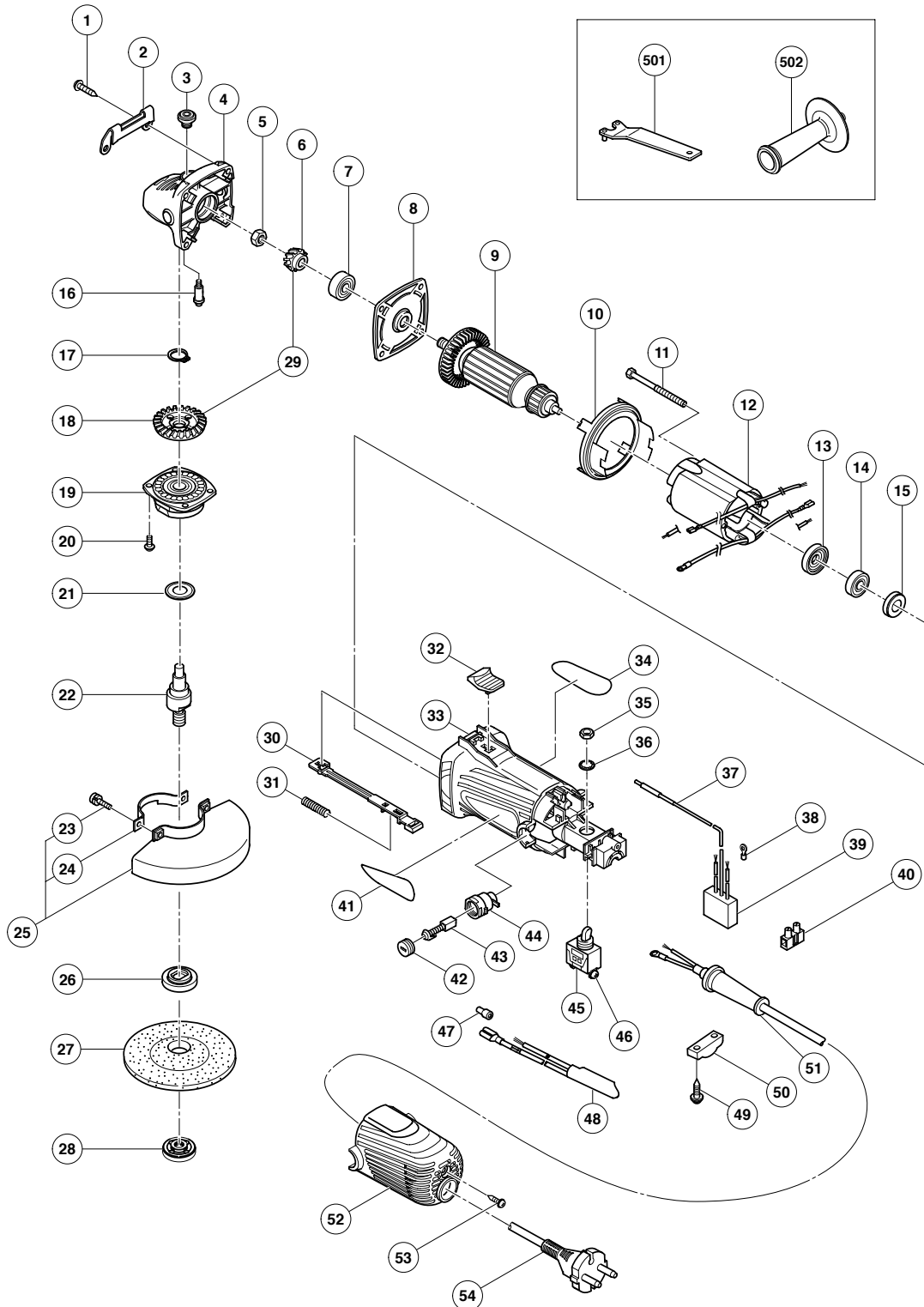

PARTS

G 10SS

ITEM NO.	CODE NO.	DESCRIPTION	NO. USED	REMARKS	
1	320-523	TAPPING SCREW D5X25 (BLACK)	4		
2	317-807	GUARD PLATE	1		
3	301-944	PUSHING BUTTON	1		
4	328-181	GEAR COVER ASS'Y	1	INCLUD. 3, 16	
5	309-191	SPECIAL NUT M6	1		
6	328-180	PINION	1		
7	608-VVM	BALL BEARING 608VVC2PS2L	1		
8	328-184	BEARING HOLDER	1		
*	9	360-802C	ARMATURE 110V	1	
*	9	360-802U	ARMATURE ASS'Y 120V	1	INCLUD. 7, 13, 14
*	9	360-802F	ARMATURE 220V	1	
*	9	360-802E	ARMATURE 230V-240V	1	
10	328-177	FAN GUIDE	1		
11	963-712	HEX. HD. TAPPING SCREW D4X65	2		
*	12	340-705C	STATOR 110V	1	
*	12	340-705G	STATOR 110V	1	FOR TPE
*	12	340-705D	STATOR 120V	1	
*	12	340-705E	STATOR 220V-230V	1	
*	12	340-705F	STATOR 240V	1	
*	12	340-705H	STATOR 240V	1	FOR AUS
13	321-722	DUST SEAL	1		
14	626-VVM	BALL BEARING 626VVC2PS2L	1		
15	309-929	RUBBER BUSHING	1		
16	301-943	LOCK PIN	1		
17	316-487	RETAINING RING FOR D11 SHAFT	1		
18	328-179	GEAR	1		
19	328-182	PACKING GLAND	1		
20	328-628	SEAL LOCK SCREW (W/WASHER) M4X12	4		
21	328-185	WASHER (A)	1		
*	22	328-174	SPINDLE	1	
*	22	328-175	SPINDLE	1	FOR USA, CAN
23	308-386	MACHINE SCREW (W/SP. WASHER) M5X16 (BLACK)	2		
24	301-949	SET PLATE	1		
25	301-948	WHEEL GUARD ASS'Y	1	INCLUD. 23, 24	
*	26	320-497	WHEEL WASHER	1	
*	26	937-834Z	WHEEL WASHER	1	FOR USA, CAN
*	27	316-820	D. C. WHEELS 100MMX4T A36Q (25 PCS.)	1	FOR NZL, AUS
*	28	321-795	WHEEL NUT (C)	1	
*	28	312-048	WHEEL NUT M10XP1.25	1	FOR USA, CAN
29	328-178	GEAR AND PINION ASS'Y	1	INCLUD. 6, 18	
30	314-427	SLIDE BAR	1		
31	314-429	SPRING	1		
32	314-428	SLIDE KNOB	1		
33	328-176	HOUSING ASS'Y	1	INCLUD.15	
34		NAME PLATE	1		
35		LOCK NUT	1		
36		LOCK WASHER	1		
*	37	314-854	EARTH TERMINAL	1	FOR NOISE SUPPRESSOR
*	38	980-063	TERMINAL	1	FOR NOISE SUPPRESSOR
*	39	994-273	NOISE SUPPRESSOR	1	FOR NZL, AUS, EUROPE, CHN, KOR, TPE
40	938-307	PILLAR TERMINAL	1		

