

ITEM	PART	QTY.	DESCRIPTION
1	0H7504A	1	ASSY FUEL TANK 9 GAL XP CARB
2	0G9029	4	SCREW TTH M8-1.25 X 20
3	0G4933	16	SCREW SWT 1/4-20 X 5/8 W/W
4	0H8149	1	PANEL SIDE XP RAW
5	052677	2	WASHER NYLON .50 X .87 X .06
6	0H7950	2	BUSHING FLANGED HEAD
7	0K8086	2	COTTER HAIRPIN .078" X 1.188"
8	0H7955	1	ASSY LIFTING BEAM XP6.5-8 RAW
9	090239	1	GASKET, EXHAUST
10	0J1708	1	MANIFOLD 410CC
11	0J3315	2	SCREW SHC M8-1.25X25 C8.8 ZP
12	040976	2	SCREW SHC M8-1.25 X 20 C12.9
13	0C4138	1	GASKET, EXHAUST PORT
14	0H6523	1	ASSY MUFFLER GT1H50
15	0G3730	5	SCREW SHC M8-1.25 X 20 SEMS

ITEM	PART	QTY.	DESCRIPTION
16	070008	1	WASHER FLAT M8 SS
17	0J1075	1	WLDMNT MTG MUFFLER ALT SIDE
18	0J2953	1	SCREW HHFC M6-1X25 8.8 W/PATCH
19	030209	1	SCREW HHFC 5/16-24 X 1-1/4 G5
20	022129	1	WASHER LOCK M8-5/16
21	0G9832	1	BRACKET, MOUNTING, ALT 7KW
22	022511	3	SCREW HHC 3/8-16 X 1-1/4 G5
23	046526	3	WASHER LOCK M10
24	0H8364	1	ENGINE GH410 XP 2010 IDL CNTRL
25	0F5579	1	SCREW HHC SHLDR M5-0.8X20 G8.8
26	0E4190	1	CLAMP, 3/16" COATED CABLE
27	0F7969	10	NUT HEX FL WHHZ M8-1.25
28	045771	3	NUT HEX M8-1.25 G8 CLEAR ZINC
29	0742600195	1	WIRE ASSY FRAME TO BATT-NEG
30	070006	1	WASHER LOCK M8 SS
31	084508A	2	VIBRATION MNT 45 ANGLE 65 DURO
32	057821	1	SCREW HHC M8-1.25 X 40 C8.8
33	081990	2	SCREW SHC M8-1.25 X 40 C8.8
34	085651	2	VIB MNT 25 X 31.8 X M8-1.25
35	0H8083	1	WELD CRADLE ALT END RAW
36	0G8590A	2	CORNER SUPPORT - OUTER XP PORT
37	0G8590B	2	CORNER SUPPORT - INNER XP PORT
38	0H8013	8	SCREW HHFC M8-1.25X60 C8.8 ZP
39	0G8584	4	BRACKET END PANEL
40	0H8152	1	PANEL END XP RAW
41	0G9035A	1	CORNER HANDLE SUPT-LFT INNER
42	0G9035B	1	CORNER HANDLE SUPT-RFT OUTER
43	0G9093	2	SCREW SHSH M8-1.25 X 40
44	0H8399	1	WELD END PANEL XP RAW
45	0G8023H	1	BATTERY CHARGER 13.4VDC 2.5A
46	0H8401	1	BRKT HOLD DOWN BATT CHRGR
47	0G6392	4	BOOT, VINYL STARTER-SOLENOID
48	089338	2	NUT HEX LOCK 1/4-20 NY INLS
49	086729	1	CONTACTOR, STARTER SOLENOID
50	022129	1	NUT HEX LOCK #8-32 W/INS BR5
51	0E3388	9	NUT HEX FL WHZ M6-1.0
52	0H8168	1	WELD HDL H-STYLE FOLD DOWN RAW
53	0H8644	2	GRIP HANDLE FOAM
54	0G9034B	1	CORNER HANDLE SUPT-RT OUTER
55	0G9034A	1	CORNER HANDLE SUPT-RT INNER
56	0K8665	1	WELD CRADLE ENGINE END RAW
57	0K6152	1	CURVED HEAD CL. VIS F/W
58	0C5786	1	VALVE, FUEL SHUT OFF
59	0H8205	1	MTG FUEL VALVE RETAINER
60	0G9560B	1	CABLE CHOKE PORT NOM 465
61	0G9549	1	SWITCH SPDT (ON)-OFF-ON 20A
62	0G9449	1	BATTERY 12V10AH SEALED
63	0K8523	2	FOOT ASSY XP
64	0H1779	4	SCREW HHFC M8-1.25 X 45
65	0J1522	4	NUT FL WHHZ M8-1.25
66	0G5737	4	PLUG PLASTIC 0.312
67	0L2176	2	SCREW HHSD PREMIUM 1/4-14X1 BZ
68	0G3110	1	SCREW RHHT M6-1.0 X 25 ZINC
69	055414	1	LUG SLDLSS #2-#8 X 17/64 CU
70	0742600194	1	GRND WIRE PORT BRG CARR-FRAME
71	0A1658	1	WASHER LOCK SPECIAL 1/4"
72	0H6130	1	WELD PANEL SIDE C-PNL XP RAW
73	0H3443	2	COTTER HAIRPIN 2.56 X .80
74	0H0653	2	WASHER FLAT 5/8 ID X 0.039" THK
75	0K8150	2	10" WHEEL OFFSET HUB
76	022247	2	WASHER FLAT 5/8 ZINC
77	0K8672	1	AXLE 15.87 DIA X 684 CLR ZINC
78	0J3708	1	WLDMNT SUPPORT MUFFLER
79	0J3826	1	J-BOLT MUFFLER M8-1.25
80	052558	1	NUT TOP LOCK FL M8-1.25
81	0J4968	3	SCREW HHFC M5-0.8 X 16
82	0J4967	2	SCREW HHFC M5-0.8 X 12
83	0H3049	1	COVER ALTERNATOR INLET 5-7KW
84	0912970099	1	WIRE, JUMPER, SOL COIL-CONTACT
85	0J0772	1	CLIP SNAP-IN WIRE MANAGEMENT
86	048031G	2	CLAMP HOSE BAND .41
87	0H3455E	1	FUEL HOSE, 160 MM LONG
88	0J1757	1	WLDMNT MTG MUFFLER HEAT SHIELD (6500W UNITS)
89	0J1076	1	WLDMNT MTG MUFFLER SIDE (8000W UNITS)
89	0H8886	1	ALT 6500W SAE BT COP-AL VN (6500W UNITS)
89	0H8887	1	ALT 8000W SAE BT COP-CO VN (8000W UNITS)
90	0H2579B	1	AVR 5.5-7.5KW VISION ALT (6500W UNITS)
90	0H2579C	1	AVR 8.0KW VISION ALTERNATOR (8000W UNITS)
91	0H8919	1	ASSEMBLY BRUSH VISION (6500W UNITS & 8000W UNITS)
92	0K2626	1	ASSY C-PNL 6.5KW XP (6500W UNITS)
92	0J2412	1	ASSY C-PNL XP 8KW (8000W UNITS)
93	0J0087	2	AXLE MNT RAW
94	0J3694	4	SCREW HHFC M6-1X50 8.8 W/PATCH
95	0A5992	2	WASHER LOCK INT M8 SS

SHEET 1 OF 2

FIRST USE	005930-3	EXPLODED VIEW
EV GENERATOR 410 PORTABLE XP		

GENERAC

Date	Revision	By	App'd
11/2/15	K4326-J	11/2/15	K4326-J

Page 1 of 4

Released For	APPD	MFG	CHKD	OWN	DWG. NO.	REV
Exploded View: EV GENERATOR 410 PORTABLE XP	KJB	GM	KC	KRL	0J2386	J
DATE	DATE	DATE	DATE	DATE		
4-8-2011	4-8-2011	4-8-2011	4-7-2011	10-18-2010		

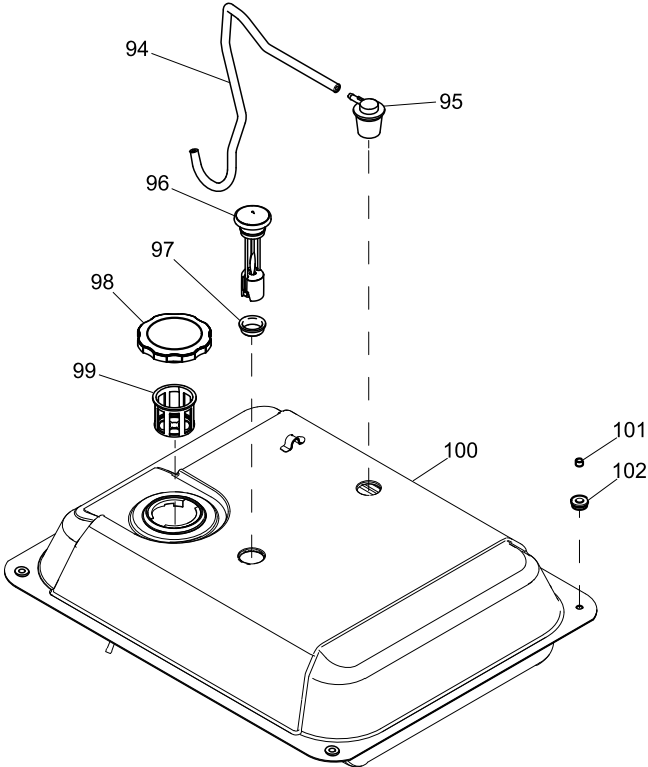

DETAIL OF GAS TANK

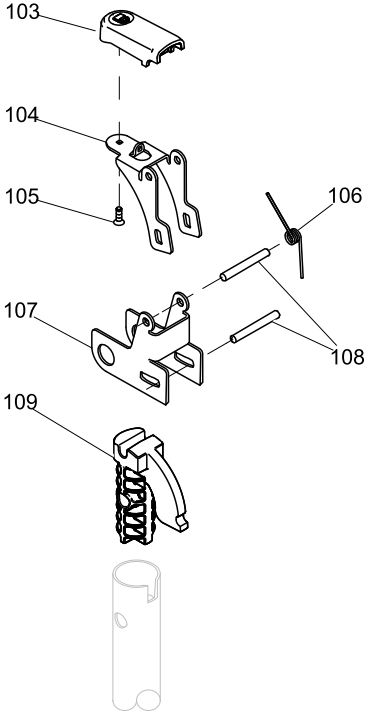

DETAIL OF HANDLE LOCK

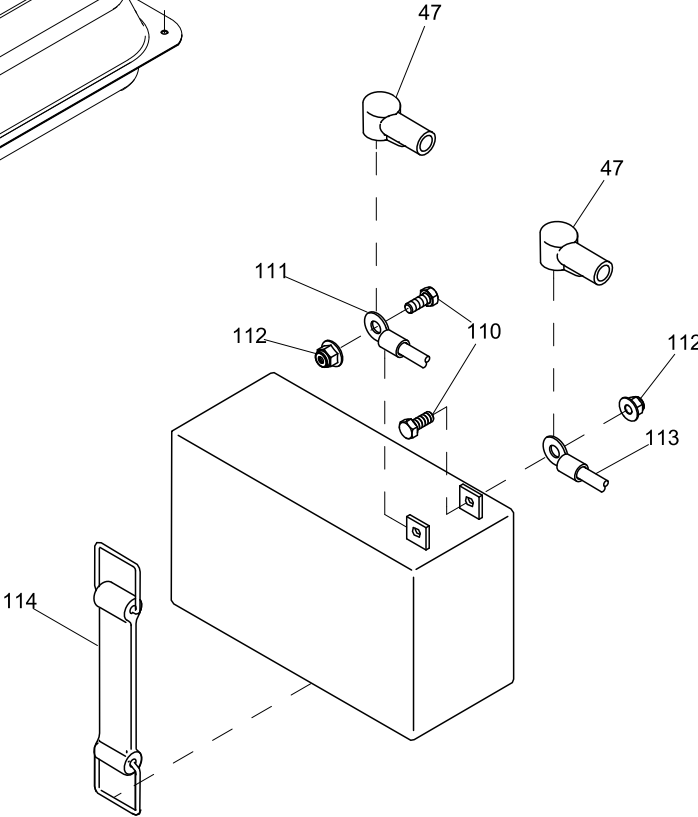

DETAIL OF BATTERY

EXPLODED VIEW: EV GENERATOR 410 PORTABLE XP

DRAWING #: 0J2386

GROUP EV

ITEM	PART#	QTY.	DESCRIPTION
		PAGE 1	
1	0H7504A	1	ASSY FUEL TANK 9 GAL XP CARB
2	0G9029	4	SCREW TTH M8-1.25 X 20
3	0G4933	16	SCREW SWT 1/4-20 X 5/8 W/W
4	0H8149	1	PANEL SIDE XP RAW
5	052677	2	WASHER NYLON .50 X .87 X .06
6	0H7950	2	BUSHING,FLANGED HEAD
7	0K8086	2	COTTER HAIRPIN .078" X 1.188"
8	0H7955	1	ASSY LIFTING BEAM XP6.5-8 RAW
9	090239	1	GASKET, EXHAUST
10	0J1708	1	MANIFOLD 410CC
11	0J3315	2	SCREW SHC M8-1.25X25 C8.8 ZP
12	040976	2	SCREW SHC M8-1.25 X 20 C12.9
13	0C4138	1	GASKET,EXHAUST PORT
14	0H6623	1	ASSY MUFFLER GTH530
15	0G3730	5	SCREW SHC M8-1.25 X 20 SEMS
16	070008	1	WASHER FLAT M8 SS
17	0J1075	1	WLDMNT MTG MUFFLER ALT SIDE
18	0J2953	1	SCREW HHFC M6-1X25 8.8 W/PATCH
19	030209	1	SCREW HHC 5/16-24 X 1-1/4 G5
20	022129	1	WASHER LOCK M8-5/16
21	0G9832	1	BRACKET, MOUNTING, ALT 7KW
22	022511	3	SCREW HHC 3/8-16 X 1-1/4 G5
23	046526	3	WASHER LOCK M10
24	0H8364	1	ENGINE GH410 XP 2010 IDL CNTRL
25	0F5579	1	SCREW HHC SHLDR M5-0.8X20 G8.8
26	0E4190	1	CLAMP, 3/16" COATED CABLE
27	067989	10	NUT HEX FL WHIZ M8-1.25
28	045771	3	NUT HEX M8-1.25 G8 CLEAR ZINC
29	0742600195	1	WIRE ASSY FRAME TO BATT-NEG
30	070006	1	WASHER LOCK M8 SS
31	084508A	2	VIBRATION MNT 45 ANGLE 65 DURO
32	057821	1	SCREW HHC M8-1.25 X 40 C8.8
33	081990	2	SCREW SHC M8-1.25 X 40 C8.8
34	085651	2	VIB MNT 25 X 31.8 X M8-1.25
35	0H8083	1	WELD CRADLE ALT END RAW
36	0G8590A	2	CORNER SUPPORT - OUTER XP PORT
37	0G8590B	2	CORNER SUPPORT - INNER XP PORT
38	0H8013	8	SCREW HHFC M8-1.25X60 C8.8 ZP
39	0G8584	4	BRACKET END PANEL
40	0H8152	1	PANEL END XP RAW
41	0G9035A	1	CORNER HANDLE SUPT-LFT INNER
42	0G9035B	1	CORNER HANDLE SUPT-LFT OUTER
43	0G9093	2	SCREW SHSH M8-1.25 X 40
44	0H8399	1	WELD END PANEL XP RAW
45	0G8023H	1	BATTERY CHARGER 13.4VDC 2.5A
46	0H8401	1	BRKT HOLD DOWN BATT CHRGR
47	0G6392	4	BOOT, VINYL STARTER-SOLENOID
48	089338	2	NUT HEX LOCK 1/4-20 NY INS
49	086729	1	CONTACTOR, STARTER SOLENOID
50	027529	2	NUT HEX LOCK #8-32 NY INS BRS
51	0E8388	9	NUT HEX FL WHIZ M6-1.0
52	0H8168	1	WELD HDL H-STYLE FOLD DOWN RAW
53	0H8644	2	GRIP HANDLE FOAM
54	0G9034A	1	CORNER HANDLE SUPT-RT OUTER
55	0G9034B	1	CORNER HANDLE SUPT-RT INNER
56	0K8665	1	WELD CRADLE ENGINE END RAW
57	0K8152	2	CURVED HEAD CLEVIS PIN
58	0C5786	1	VALVE, FUEL SHUT OFF
59	0H8205	1	MTG FUEL VALVE RETAINER
60	0G9560B	1	CABLE CHOKE PORT NOM 465
61	0G9549	1	SWITCH SPDT (ON)-OFF-ON 20A
62	0G9449	1	BATTERY 12V10AH SEALED
63	0K8523	2	FOOT ASSY XP
64	0H1779	4	SCREW HHFC M8-1.25 X 45

EXPLODED VIEW: EV GENERATOR 410 PORTABLE XP

DRAWING #: 0J2386

GROUP EV

ITEM	PART#	QTY.	DESCRIPTION
65	0J9125	4	NUT HEX FL WHIZ M8-1.25
66	0G5737	4	PLUG PLASTIC 0.312
67	0L2176	2	SCREW HHSD PREMIUM 1/4-14X1 BZ
68	0G3110	1	SCREW HHTT M6-1.0 X 25 ZINC
69	055414	1	LUG SLDLSS #2-#8 X 17/64 CU
70	0742600194	1	GRND WIRE PORT BRG CARR-FRAME
71	0A1658	1	WASHER LOCK SPECIAL 1/4"
72	0H8130	1	WELD PANEL SIDE C-PNL XP RAW
73	0H3443	2	COTTER HAIRPIN 2.56 X .80
74	0H0653	2	WASHER FLAT 5/8 ID X 0.039"THK
75	0K8150	2	10" WHEEL OFFSET HUB
76	022247	2	WASHER FLAT 5/8 ZINC
77	0K8672	1	AXLE 15.87 DIA X 684 CLR ZINC
78	0J3708	1	WLDMNT SUPPORT MUFFLER
79	0J3826	1	J-BOLT MUFFLER M8-1.25
80	052858	1	NUT TOP LOCK FL M8-1.25
81	0J4968	3	SCREW HHFC M5-0.8 X 16
82	0J4967	2	SCREW HHFC M5-0.8 X 12
83	0H3049	1	COVER ALTERNATOR INLET 5-7KW
84	0912970099	1	WIRE, JUMPER,SOL COIL-CONTACT
85	0J0772	1	CLIP SNAP-IN WIRE MANAGEMENT
86	048031G	2	CLAMP HOSE BAND .41
87	0H3455E	1	FUEL HOSE, 160 MM LONG
88	0J1757	1	WLDMNT MTG MUFFLER HEAT SHIELD (6500W UNITS)
	0J1076	1	WLDMNT MTG MUFFLER SIDE (8000W UNITS)
89	0H8886	1	ALT 6500W SAE BT COP-AL VN (6500W UNITS)
	0H8887	1	ALT 8000W SAE BT COP-CO VN (8000W UNITS)
90	0H2579B	1	AVR 5.5-7.5KW VISION ALT (6500W UNITS)
	0H2579C	1	AVR, 8.0KW VISION ALTERNATOR (8000W UNITS)
91	0H0919	1	ASSEMBLY,BRUSH VISION (6500W UNITS & 8000W UNITS)
92	0K2626	1	ASSY C-PNL 6.5KW XP (6500W UNITS)
	0J2412	1	ASSY C-PNL XP 8KW (8000W UNITS)
93	0J0087	2	AXLE MNT RAW
94	0J3694	4	SCREW HHFC M6-1X50 8.8 W/PATCH
95	0A5992	2	WASHER LOCK INT M8 SS
PAGE 2			
94	0H1207F	1	HOSE 11MM OD X 5.5MM ID X 26IN
95	0H1142	1	ASSY, ROLL OVER SLANT VALVE
96	0H7520A	1	FUEL GAUGE,ROUND 6.5" LONG
97	0H7521	1	GROMMET FUEL GAUGE ROUND
98	0H0958A	1	ASSY GAS CAP SEALED - BLACK
99	0H1326	1	FILTER, FUEL
100	0H7503A	1	WELDMENT FUEL TANK XP RAW CAL
101	0H1610	4	INSERT, ANTI-CRUSH FOR TANKS
102	0H1411	4	RUBBER MOUNT, 10.8 ID X 9 TALL
103	0G9039	2	BUTTON LATCH RELEASE
104	0G9038	2	LEVER, LATCH RELEASE
105	0G9096	2	SCREW PFHP #8-16 X 1/2
106	0G9040	2	SPRING TORSION, LATCH RELEASE
107	0G9037	2	BRACKET, LATCH
108	0G9041	4	PIVOT PIN, LATCH RELEASE
109	0G9036	2	PLUG, FOLD DOWN HANDLE
110	052618	2	SCREW HHC M5-0.8 X 12 C8.8
111	0742600183	1	WIRE, #16 START SOL-STARTER XP
112	0H3535	6	NUT FLANGE M5-0.8 NYLOCK
113	0742600196	1	WIRE ASSY SOL TO BATT-POS
114	0H7945	1	ASSEMBLY, BATTERY STRAP

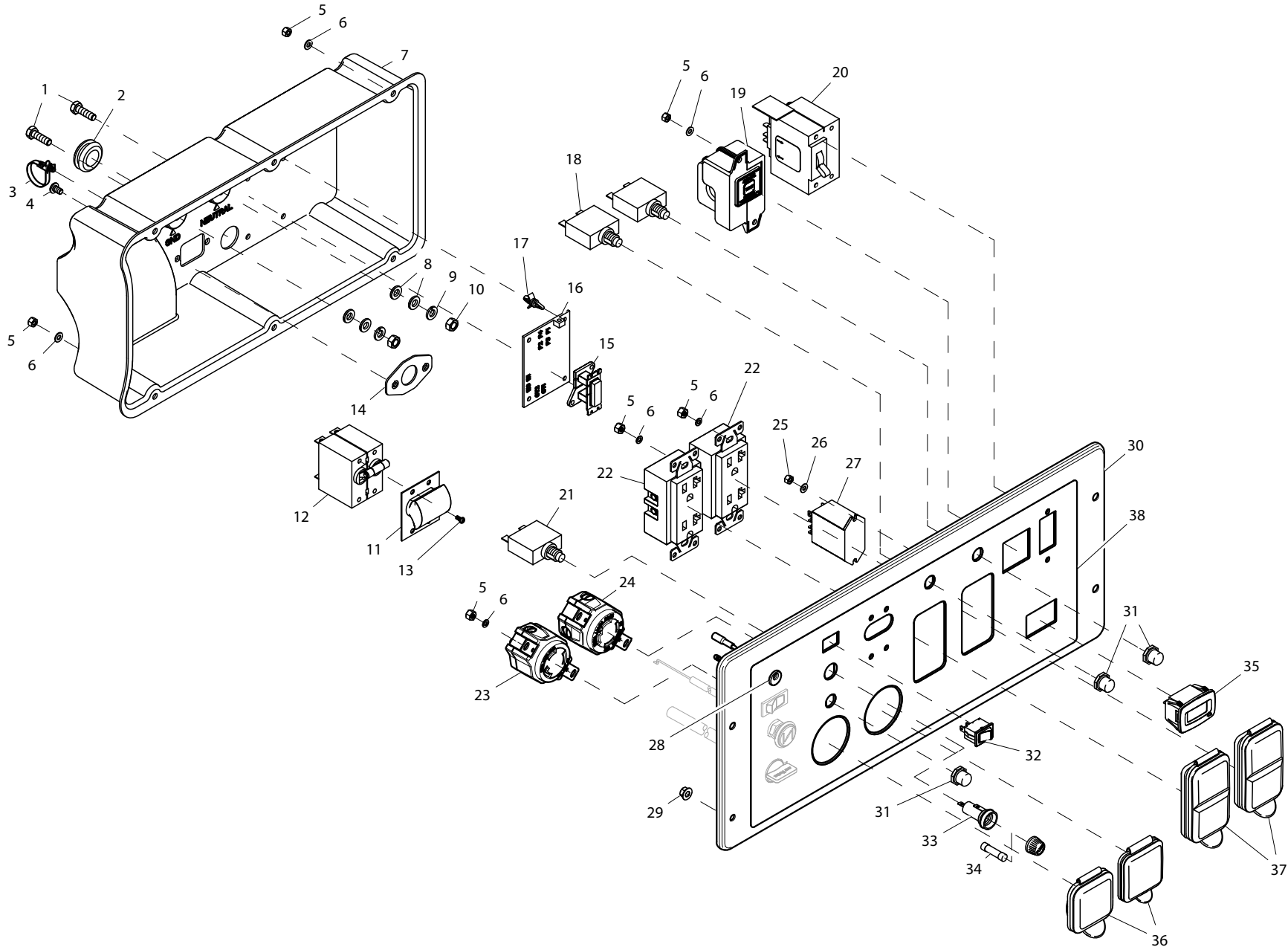

ITEM	PART	QTY.	DESCRIPTION
1	042568	2	SCREW HHC M6-1.0 X 20 C8.8
2	029107	2	GROMMET 7/8 X 3/16 X 5/8
3	0J7549	1	TIE WRAP PUSH MNT QUICK REL
4	0E5333	2	SCREW PHTT M5-0.8 X 8 ZINC
5	0E6480	16	NUT HEX LOCK M4-0.7 NY INS
6	043180	16	WASHER FLAT M4
7	0H8118	1	CONTROL BOX XP6.5-8KW PORTABLE
8	049811	4	WASHER FLAT M6
9	022097	2	WASHER LOCK M6-1/4
10	049813	2	NUT HEX M6-1.0 G8 CLEAR ZINC
11	0C7340	1	BOOT, CIRCUIT BREAKER
12	0G9023C	1	CB 0030A 2P 240V C AA2 QT
13	036900	6	SCREW PPHM #6-32 X 1/4
14	0H3349	1	WIRE ADAPTER PLATE
15	084028	1	TRANSFORMER IDLE CNT
16	0H8447	1	ASSY PCB XP PORTABLE CONT.
17	040213C	4	PCB SUPPORT SNAP-IN 3/16"
18	0H0265C	2	CB 20A 1P 120V CUL/CSA JOEMEX
19	0G6017	1	GFCI SENSING MODULE ASSEMBLY
20	0G5644	1	CB 2P 35A W/SHUNT TRIP
21	0H0265E	1	CB 30A 1P 120V CUL/CSA JOEMEX
22	0D4968	2	OUTLET 20A 120V DPLX 6342BK
23	068868	1	OUTLET 30A 120V RECEP
24	0G8758	1	OUTLET 30A 120/250V SPCGR
25	0D9784	2	NUT HEX LOCK M3-0.5 NY INS
26	052777	2	WASHER FLAT M3
27	0E3927	1	RELAY, DPDT NO 10A 120VAC COIL
28	0H9126	1	ASSY 12VDC POWER JACK XP
29	0E8388	4	NUT HEX FL WHIZ M6-1.0
30	0H8458	1	ASSY COVER C-PNL XP 8KW
31	0J3223	3	BOOT/NUT, SWITCH COVER
32	087968	1	SWITCH, ROCKER -/0
33	0H6856	1	FUSE HOLDER 10A/250VAC R3-13
34	067682D	1	FUSE SLOBLO 1.5A GLASS
35	0H8214	1	HOUR METER W/ALERTS AC/DC
36	0G9391	2	COVER, 30A 120/240V
37	0G9392	2	COVER, 20A 120V GFCI/DUPLEX
38	0H8564	1	OVERLAY CONTROL PANEL XP8