

PART NO. 0G9666

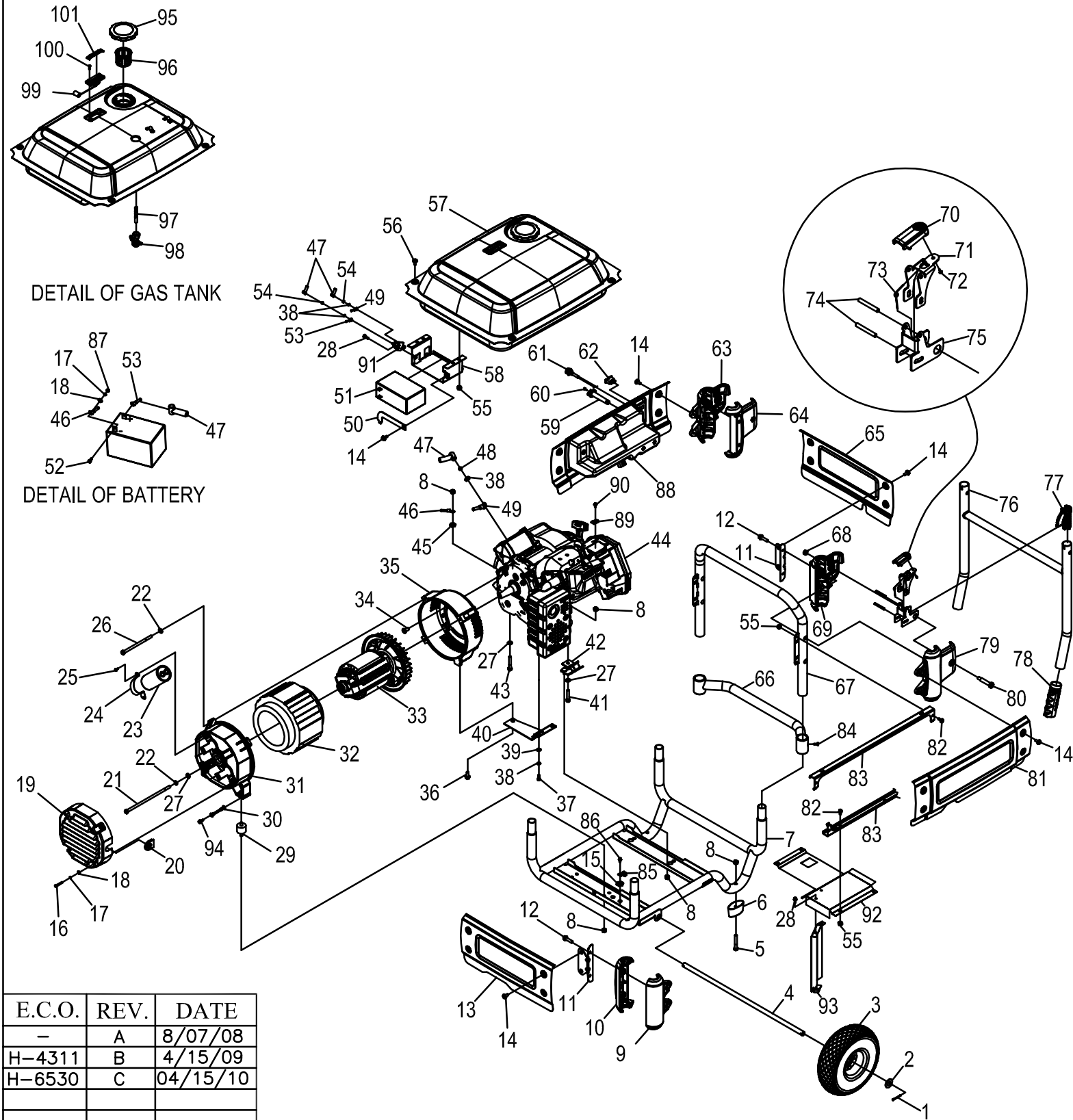

DETAIL OF GAS TANK

DETAIL OF BATTERY

E.C.O.	REV.	DATE
-	A	8/07/08
H-4311	B	4/15/09
H-6530	C	04/15/10

DO NOT SCALE

ITEM	PART #	QTY.	DESCRIPTION	ITEM	PART #	QTY.	DESCRIPTION
1	0D4999	2	COTTER PIN	58	0G8587	1	TRAY, BATTERY
2	0H0653	2	FLAT WASHER 5/8" X 0.039" THICK	59	0G9058	1	KNOB, FUEL SHUTOFF
3	0G8582	2	10" WHEEL	60	0E9530	1	SCREW PPHM M3-0.5 X 10 SEMS
4	0G5205	1	AXLE	61	0G9560	1	CABLE, CHOKE
5	039288	2	SCREW HHC M8-1.25 X 55	62	0G9549	1	SWITCH, START-RUN-STOP
6	0G9055	2	FOOT	63	0G9034A	1	CORNER SUPPORT, OUTER RIGHT SIDE HANDLE
7	0G8387	1	LOWER CRADLE	64	0G9034B	1	CORNER SUPPORT, INNER RIGHT SIDE HANDLE
8	049820	11	NUT HEX LOCK M8-1.25 NYLON INSERT	65	0G8585A	1	END PANEL, ENGINE SIDE
9	0G8590A	2	CORNER SUPPORT, OUTER	66	0G8389	2	CRADLE, HANDLE
10	0G8590B	2	CORNER SUPPORT, INNER	67	0G8388	2	CRADLE, UPPER
11	0G8584	4	BRACKET, END PANEL	68	045771	2	NUT HEX M8-1.25
12	0H8013	8	SCREW HHFC M8-1.25 X 60 C8.8 ZP	69	0G9035B	1	CORNER SUPPORT, INNER LEFT SIDE HANDLE
13	0G8585B	1	END PANEL, ALTERNATOR SIDE	70	0G9039	2	BUTTON, LATCH RELEASE
14	0G4933	17	SCREW SWT 1/4 - 20 X 5/8	71	0G9038	2	LEVER, LATCH RELEASE
15	0A1658	1	WASHER SPECIAL LOCK 1/4	72	0G9096	2	SCREW PFHP #8-16 X 1/2
16	020911	4	SCREW PPHM M5-0.8 X 30	73	0G9040	2	TORSION SPRING, LATCH RELEASE
17	022152	6	WASHER LOCK #10	74	0G9041	4	PIVOT PIN, LATCH RELEASE
18	023887	6	WASHER FLAT #10	75	0G9037	2	BRACKET, LATCH
19	0G5002	1	COVER, ALTERNATOR	76	0G8589	1	HANDLE, FOLD DOWN
20	0G5206	1	GROMMET, WIRE SLEEVE	77	0G9036	2	PLUG, HANDLE FOLD DOWN
21	075431	1	SCREW HHC 5/16-24 X 8-1/2 (8KW)	78	097612	2	GRIP, HANDLE
22	0H0037	1	SCREW HHC 5/16-24 X 7-1/2 (6.5KW)	79	0G9035A	1	CORNER SUPPORT, OUTER LEFT SIDE HANDLE
23	022129	5	WASHER LOCK M8	80	0G9093	2	SCREW SHSH M8-1.25 X 40
24	0G5958	1	CAPACITOR	81	0G8586B	1	SIDE PANEL
25	0G5088	1	CAPACITOR CLAMP	82	0G1705	12	SCREW HHFC M6-1.0 X 14
26	0F4795	2	SCREW PPHM M4-0.7 X 10 SEMS	83	0G8583	4	SIDE RAIL
27	0G5148	4	SCREW HHC M8-1.25 X 140 (8KW)	84	0G9030	4	SCREW PHT 1/4-1/4 X 3/4 TEK
28	073941	4	SCREW HHC M8-1.25 X 115 (6.5KW)	85	055414	1	GROUND LUG
29	022145	4	WASHER FLAT M8	86	0D6029	1	SCREW HHTT M6-1.0 X 16
30	090388	5	SCREW HHTT M6-1.0 X 12	87	051716	2	NUT HEX M5-0.8
31	085652	2	VIBRATION MOUNT	88	0G8826	1	CONTROL PANEL (8KW)
32	074260174	1	GROUND WIRE	89	0G9710	1	CONTROL PANEL (6.5KW)
33	0G2398	1	CARRIER, REAR BEARING	90	0E4190	1	CLAMP, CABLE
34	0G9662C	1	STATOR (8KW)	91	0F5579	1	SCREW SHOULDER M5-0.8 X 20
35	0G9663C	1	STATOR (6.5KW)	92	086729	1	STARTER CONTACTOR
36	0G5211C	1	ROTOR (8KW)	93	0H0318	1	HEAT SHIELD
37	0G9664C	1	ROTOR (6.5KW)	94	0H0319	1	DEFLECTOR
38	030205	4	SCREW HSC 3/8-16 X 3/4	95	0G3111	1	SCREW HHTT M6-1.0 X 25
39	0G2397	1	HOUSING, ENGINE ADAPTOR	96	0H1325	1	FUEL CAP, VENTED, BLACK CAP
40	0D4662	1	SCREW HHTR 5/16-18 X 3/4	97	0H1326	1	FUEL FILTER
41	047411	2	SCREW HHC M6-1.0 X 16	98	0H1613	1	FILTER, FUEL VALVE
42	022097	5	WASHER LOCK M6	99	0H1611	1	FUEL VALVE
43	022473	2	WASHER FLAT M6	100	0H1345	1	FUEL GAGE, 153MM LONG ARM
44	0G1746	1	MUFFLER, BRACKET	101	0H1357	2	SCREW PFHM M5-0.8 X 12
45	081990	2	SCREW SHC M8-1.25 X 40				
46	084508A	2	VIBRATION MOUNT, 45 ANGLE				
47	057821	1	SCREW HHC M8-1.25 X 40				
48	0G9655	1	ENGINE, 410CC XP PORTABLE				
49	0C3168	1	WASHER LOCK SPECIAL 5/16				
50	074260185	1	WIRE, NEGATIVE TO ENGINE FRAME				
51	0G6392	4	BOOT				
52	049813	1	NUT HEX M6 YELLOW CHROME				
53	074260183	1	WIRE, STARTER TO SOLENOID				
54	0G9557	1	BRACKET, BATTERY HOLD DOWN				
55	0G9449	1	BATTERY				
56	052618	2	SCREW HHC M5-0.8 X 12				
57	074260184	1	WIRE, BATTERY TO SOLENOID				
	022127	2	NUT HEX 1/4				
	0D3700	16	NUT FLANGE M6 NYLOK				
	0G9029	4	SCREW TTH M8-1.25 X 20				
	0G8592	1	FUEL TANK				

GROUP

EXPLODED VIEW:		GENERATOR PARTS		GENERAC POWER SYSTEMS	
DRAWN BY:	M. BECHTEL	DATE:	6/05/08	P.O. BOX 8 WAUKESHA, WIS. 53186	
CHECKED BY:	C. RICHARDSON	DATE:	8/07/08	FIRST USE:	005606
APPROVED BY:	C. TURNER	DATE:	8/07/08	PART NO.:	0G9666
RELEASED FOR PRODUCTION BY:	C. TURNER	DATE:	8/07/08	REV.:	C

GROUP

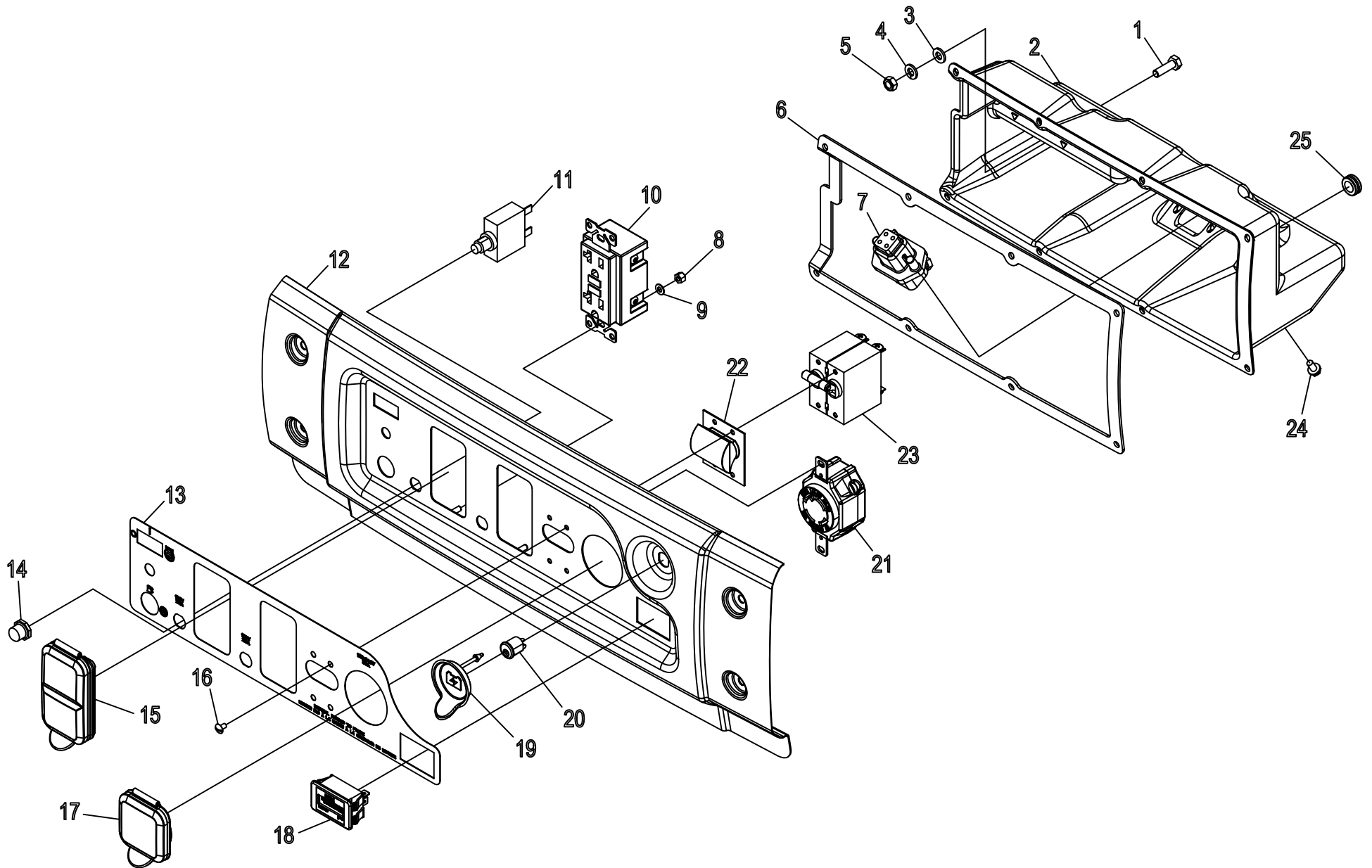

**EXPLODED VIEW: CONTROL PANEL****DRAWING #: 0G9720****APPLICABLE TO: 005806****GROUP**

<b>ITEM</b>	<b>PART #</b>	<b>QTY.</b>	<b>DESCRIPTION</b>
1	042568	2	SCREW HHC M6-1.0. X 20
2	0G8588	1	CONTROL PANEL BOX
3	049811	2	WASHER, FLAT M6
4	022097	2	WASHER, LOCK M6
5	049813	2	NUT HEX M6 YELLOW CHROME
6	0G9537	1	GASKET, CONTROL PANEL
7	0G9551	1	WIRE HARNESS (8KW) (NOT SHOWN)
	0G9709	1	WIRE HARNESS (6.5KW) (NOT SHOWN)
8	0E6480	14	NUT HEX LOCK M4-0.7 NYLON INSERT
9	043180	14	WASHER, FLAT M4
10	0D4966	2	OUTLET, 20A GFCI DUPLEX BLACK
11	0H0265C	2	CIRCUIT BREAKER 20X1
12	0G8586A	1	CONTROL PANEL
13	0G9070	1	OVERLAY, CONTROL PANEL
14	0C7341	2	BOOT/NUT, PUSH BUTTON SWITCH
15	0G9392	2	COVER, 20A 120V GFCI DUPLEX
16	025105	4	SCREW RHMS 6-32 X 1/4
17	0G9391	1	COVER 30A 120/240 OUTLET
18	0G8321	1	HOUR METER
19	0G9393	1	COVER, 12V DC JACK OUTLET
20	0G5699	1	12VDC POWER JACK
21	0G8758	1	RECEPTACLE 30A
22	0C7340	1	BOOT, CIRCUIT BREAKER
23	0G9023C	1	30A CIRCUIT BREAKER (8KW)
	0G9023E	1	27A CIRCUIT BREAKER (6.5KW)
24	0F5458	2	SCREW PLASTITE HI-LOW #10 X 3/8
25	042632	1	GROMMET 1/2 X 1/16 X 3/8

APPLICABLE TO:

MUFFLER OPTION  
ENGINE PRODUCTION LEVEL 9E

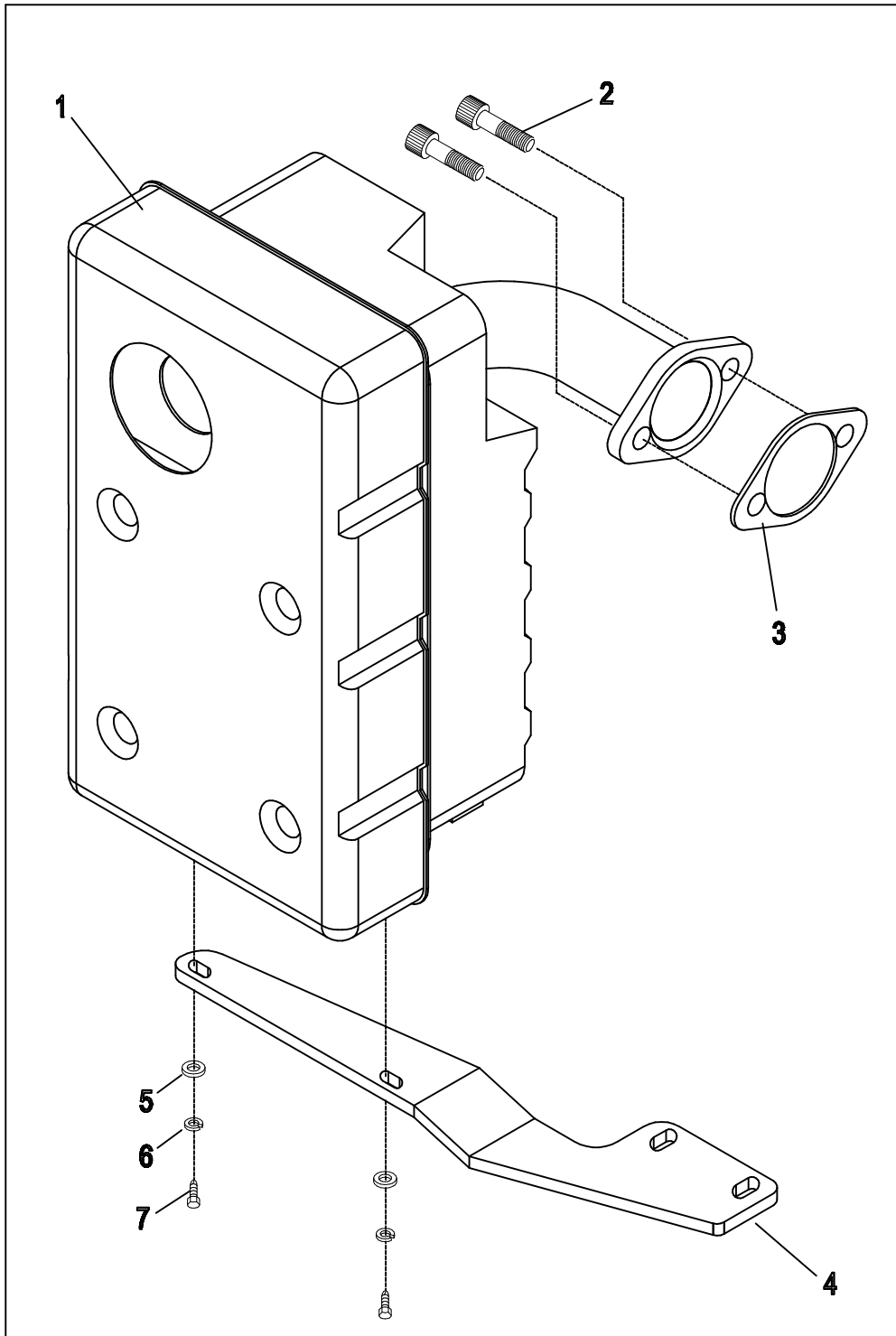

**EXPLODED VIEW: MUFFLER, 410 SIDE OUT  
DRAWING #: 0E5081 REV. B**

**GROUP**

**APPLICABLE TO:**

<b>ITEM</b>	<b>PART #</b>	<b>QTY.</b>	<b>DESCRIPTION</b>
1	0E5223A	1	MUFFLER, 410 SIDE-OUT ALUMINIZED
2	0G3730	2	SCREW SHC M8-1.25 X 20 SEMS
3	090239	1	GASKET, EXHAUST
4	0E6047	1	BRACKET, GH410 MUFFLER SUPPORT
5	022473	2	WASHER FLAT ¼ - M6 ZINC
6	022097	2	WASHER LOCK M6 - ¼
7	043146	2	SCREW HHC M6-1.0 X 10 G8.8

FLYWHEEL OPTION  
ENGINE PRODUCTION LEVEL 10E

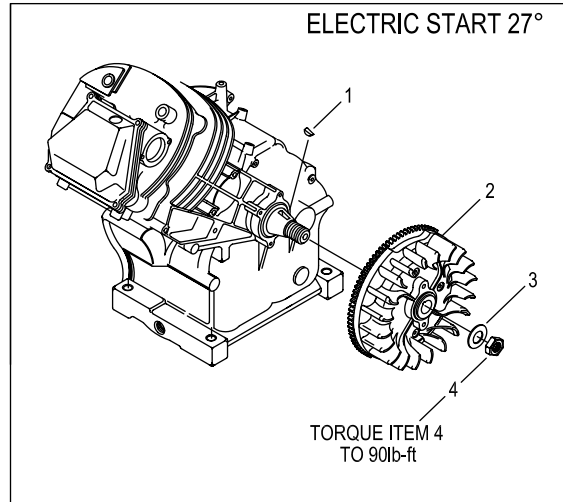

1	082774	1	KEY, WOODRUFF 4 x 19D
2	091222C	1	ASSY, FLYWHEEL W/RING GEAR 27 DEGREE
3	067198N	1	WASHER, BELV-20 X 2.2
4	067890	1	NUT, HEX – FLYWHEEL