

ELITE

HIGH PERFORMANCE MACHINERY

Operating Instructions and Parts Manual

1700 Series Lathe

Models: EGH-1740 | EGH-1760

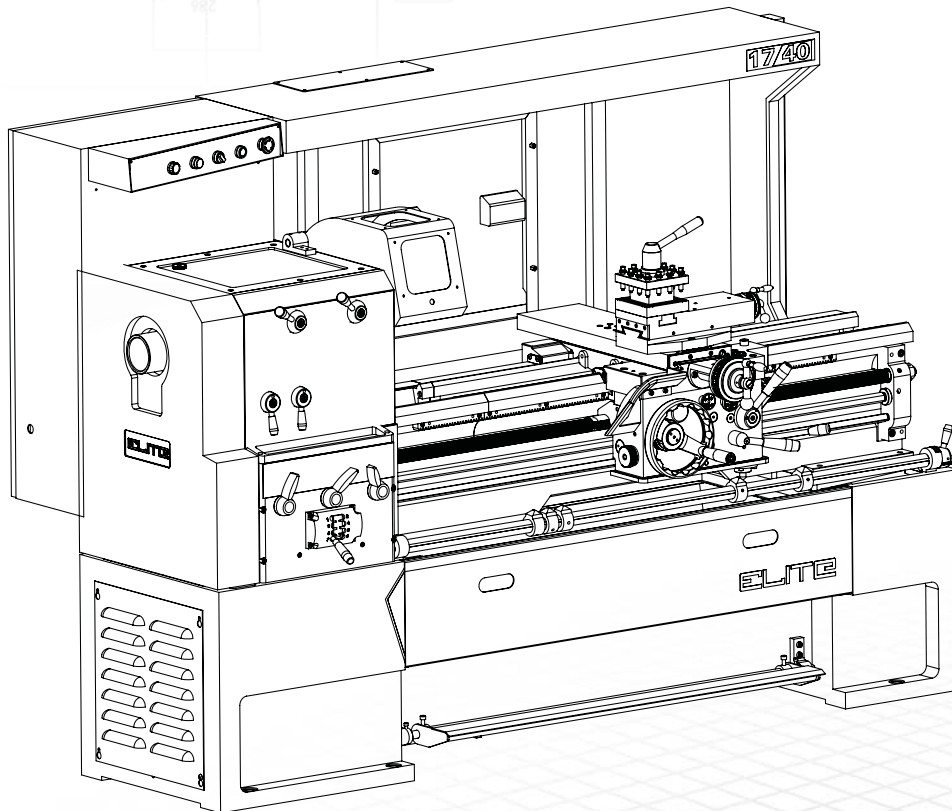

JET®

427 New Sanford Road
LaVergne, Tennessee 37086
www.jettools.com
Ph.: 855-336-4032

Part No. M-EGH-1740
REV C1 07/2015
Copyright © 2015 JET

HEADSTOCK ASSEMBLY

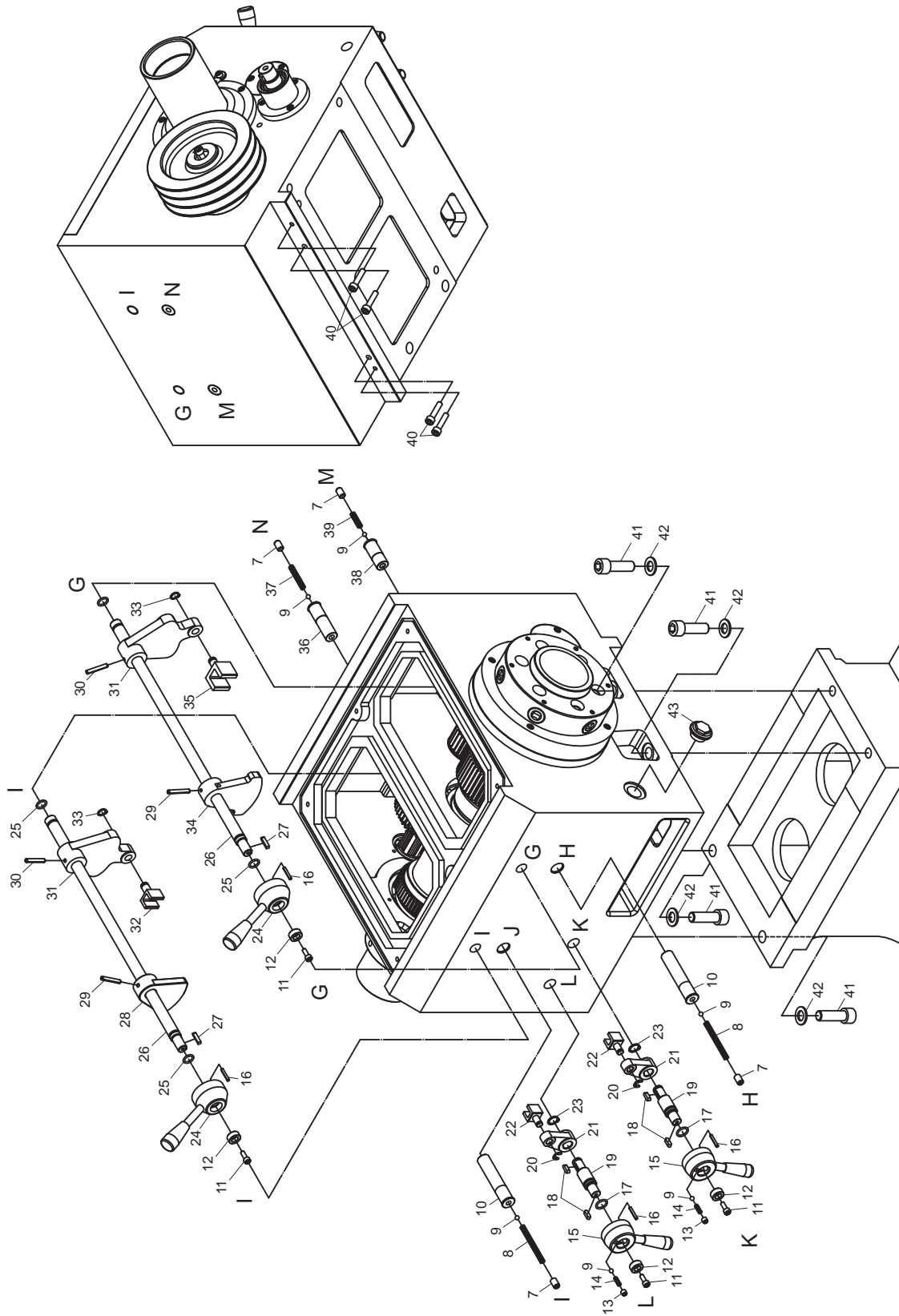

HEADSTOCK ASSEMBLY

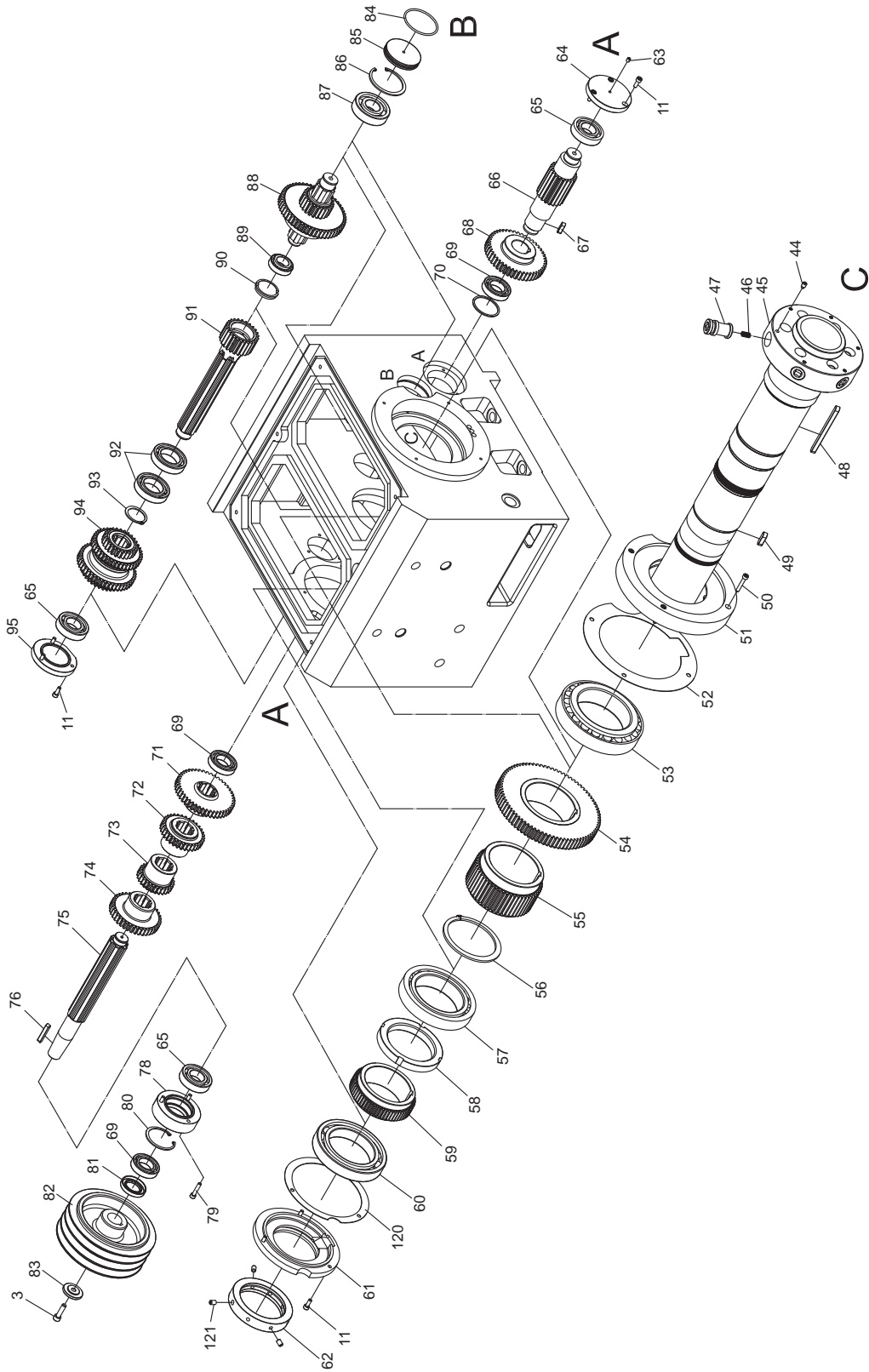

HEADSTOCK ASSEMBLY

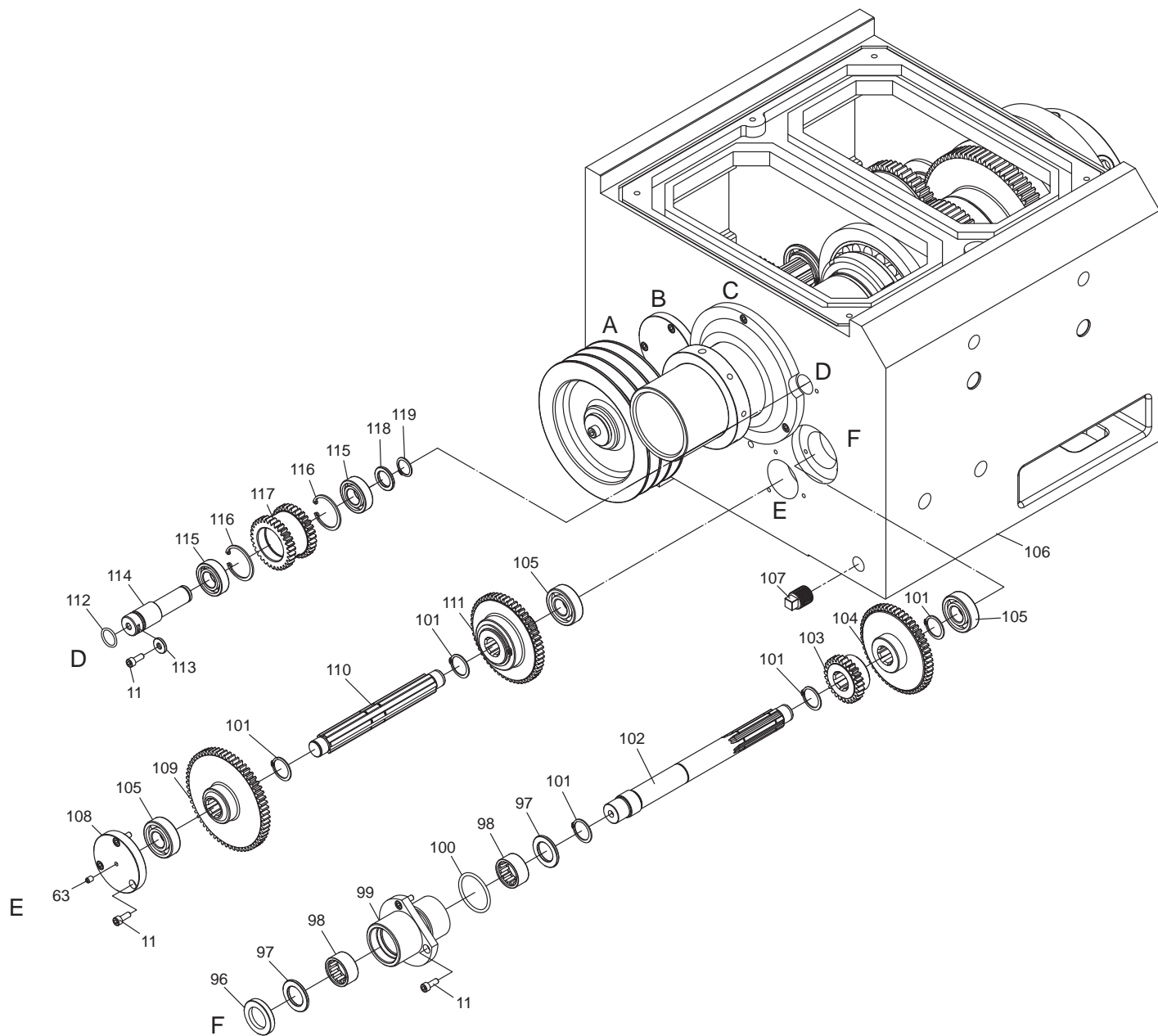

HEADSTOCK ASSEMBLY PARTS LIST

Index No.	Part No.	Description	Size	Qty.
1	EGH1740-A01	Oil Cover	3/4"	1
2	TS-1504061	Hex. Socket Head Bolt	CAP 8x30	7
3	EGH1740-A03	Headstock Cover		1
4	EGH1740-A04	"O" Ring	Ø4x1800	1
5	EGH1740-A05	Name Plate		1
6	EGH1740-A06	Rivet	Ø2	4
7	TS-1525031	Set Screw	SET 10x16	4
8	EGH1740-A08	Spring		2
9	EGH1740-A09	Steel Ball	Ø1/4"	6
10	EGH1740-A10	Bush		2
11	TS-1503041	Hex. Socket Head Bolt	CAP 6x16	20
12	EGH1740-A12	Washer		4
13	TS-1524011	Set Screw	SET 8x8	2
14	EGH1740-A14	Spring		2
15	EGH1740-A15	Hub & Handle	Assembly for replacement	2
16	EGH1740-A16	Spring Pin	Ø4x25	4
17	EGH1740-A17	"O" Ring	P16	2
18	EGH1740-A18	Key	5x5x16L	4
19	EGH1740-A19	Shaft		2
20	EGH1740-A20	Clip	E8	2
21	EGH1740-A21	Clip		2
22	EGH1740-A22	Fork		2
23	EGH1740-A23	Clip	S15	2
24	EGH1740-A24	Hub & Handle	Assembly for replacement	2
25	EGH1740-A25	"O" Ring	P14	4
26	EGH1740-A26	Rod		2
27	EGH1740-A27	Key	5x5x22L	2
28	EGH1740-A28	Lever		1
29	EGH1740-A29	Spring Pin	Ø6x36	1
30	EGH1740-A30	Spring Pin	Ø6x40	2
31	EGH1740-A31	Lever		2
32	EGH1740-A32	Fork		1
33	EGH1740-A33	Clip (S12)		2
34	EGH1740-A34	Lever		1
35	EGH1740-A35	Lever		1
36	EGH1740-A36	Bush		1
37	EGH1740-A37	Spring		1
38	EGH1740-A38	Bush		1
39	EGH1740-A39	Spring		1
40	EGH1740-A40	Hex. Socket Head Bolt	CAP 8x35	4
41	EGH1740-A41	Hex. Socket Head Bolt	CAP 6x50	4



Index No.	Part No.	Description	Size	Qty.
42	TS-155010	Washer	M16	4
43	EGH1740-A43	Oil sight	3/4"	1
44	EGH1740-A44	Set screw		6
45	EGH1740-A45	Spindle		1
46	EGH1740-A46	Spring		6
47	EGH1740-A47	Cams		6
48	EGH1740-A48	Key	12x8x120L	1
49	EGH1740-A49	Key	12x8x30L	1
50	TS-1503081	Hex. Socket Head Bolt	CAP 6x35	3
51	EGH1740-A51	Front Bearing Cover		1
52	EGH1740-A52	Packing F		1
53	BB-32022	Taper Roller Bearing	32022X	1
54	EGH1740-A54	Gear(82T)		1
55	EGH1740-A55	Gear(53T)		1
56	EGH1740-A56	Clip(S105)		1
57	BB-32020	Taper Roller Bearing	32020X	1
58	EGH1740-A58	Nut	YSR100	1
59	EGH1740-A59	Gear(62T)		1
60	BB-6019	Ball Bearing	6019	1
61	EGH1740-A61	Outside Cover		1
62	EGH1740-A62	Balance Ring		1
63	TS-1523021	Set Screw	SET 6x8	2
64	EGH1740-A64	Cover		1
65	BB-6206	Ball Bearing	6206	3
66	EGH1740-A66	Gear Shaft (20T)		1
67	EGH1740-A67	Key	8x7x25L	1
68	EGH1740-A68	Gear(47T)		1
69	BB-6006	Ball Bearing	6006	3
70	EGH1740-A70	Collar		1
71	EGH1740-A71	Gear(46T)		1
72	EGH1740-A72	Gear(33T)		1
73	EGH1740-A73	Gear(27T)		1
74	EGH1740-A74	Gear(39T)		1
75	EGH1740-A75	Shaft	A	1
76	EGH1740-A76	Key	7x7x45L	1
78	EGH1740-A78	Flanged Bearing	A	1
79	TS-1503071	Hex. Socket Head Bolt	CAP 6x30	3
80	EGH1740-A80	Clip(R58)		1
81	EGH1740-A81	Oil Seal	TC30x50x08	1
82	EGH1740-A82	Pulley	V	1
83	EGH1740-A83	Washer		1
84	EGH1740-A84	"O" Ring	G65	1

Index No.	Part No.	Description	Size	Qty.
85	EGH1740-A85	Plug		1
86	EGH1740-A86	Clip (R72)		1
87	BB-6306	Ball bearing	6306	1
88	EGH1740-A88	Gear(23T),(25T/52T),Key (8x7x25),Clip(S50),Shaft	Assembly for replacement	1
89	EGH1740-A89	Taper Roller Bearing		1
90	EGH1740-A90	Washer		1
91	EGH1740-A91	Gear Shaft (25T)		1
92	BB-6008	Ball bearing	6008	2
93	EGH1740-A93	Clip(S38)		1
94	EGH1740-A94	Gear(26T),(39T),(45T),(33T),Key (8x7x70),Clip(S55)	Assembly for replacement	
95	EGH1740-A95	Cover		1
96	EGH1740-A96	Oil Seal	TC28x44x07	1
97	EGH1740-A97	Washer		2
98	EGH1740-A98	Needle Bearing	RNA6904	2
99	EGH1740-A99	Flanged Bearing		1
100	EGH1740-A100	"O" Ring	P44	1
101	EGH1740-A101	Clip(R25)		5
102	EGH1740-A102	Shaft	F	1
103	EGH1740-A103	Gear(27T)		1
104	EGH1740-A104	Gear(54T)		1
105	BB-6204	Ball Bearing	6204	3
106	EGH1740-A106	Head Stock		1
	EGH1760-A106	Head Stock		1
107	EGH1740-A107	Square Head Plug	PT 1/2"	1
108	EGH1740-A108	Cover		1
109	EGH1740-A109	Gear(62T)		1
110	EGH1740-A110	Shaft	E	1
111	EGH1740-A111	Gear(27T),(54T),Key (7x7x20),Clip(S45)	Assembly for replacement	1
112	EGH1740-A112	"O" Ring	P20	1
113	EGH1740-A113	Washer		1
114	EGH1740-A114	Shaft	D	1
115	BB-6004	Ball Bearing	6004	2
116	EGH1740-A116	Clip (R42)		2
117	EGH1740-A117	Gear(31T)		1
118	EGH1740-A118	Washer		1
119	EGH1740-A119	Clip (S20)		1
121	TS-1524031	Set Screw	SET 8x12	3

GEARBOX ASSEMBLY

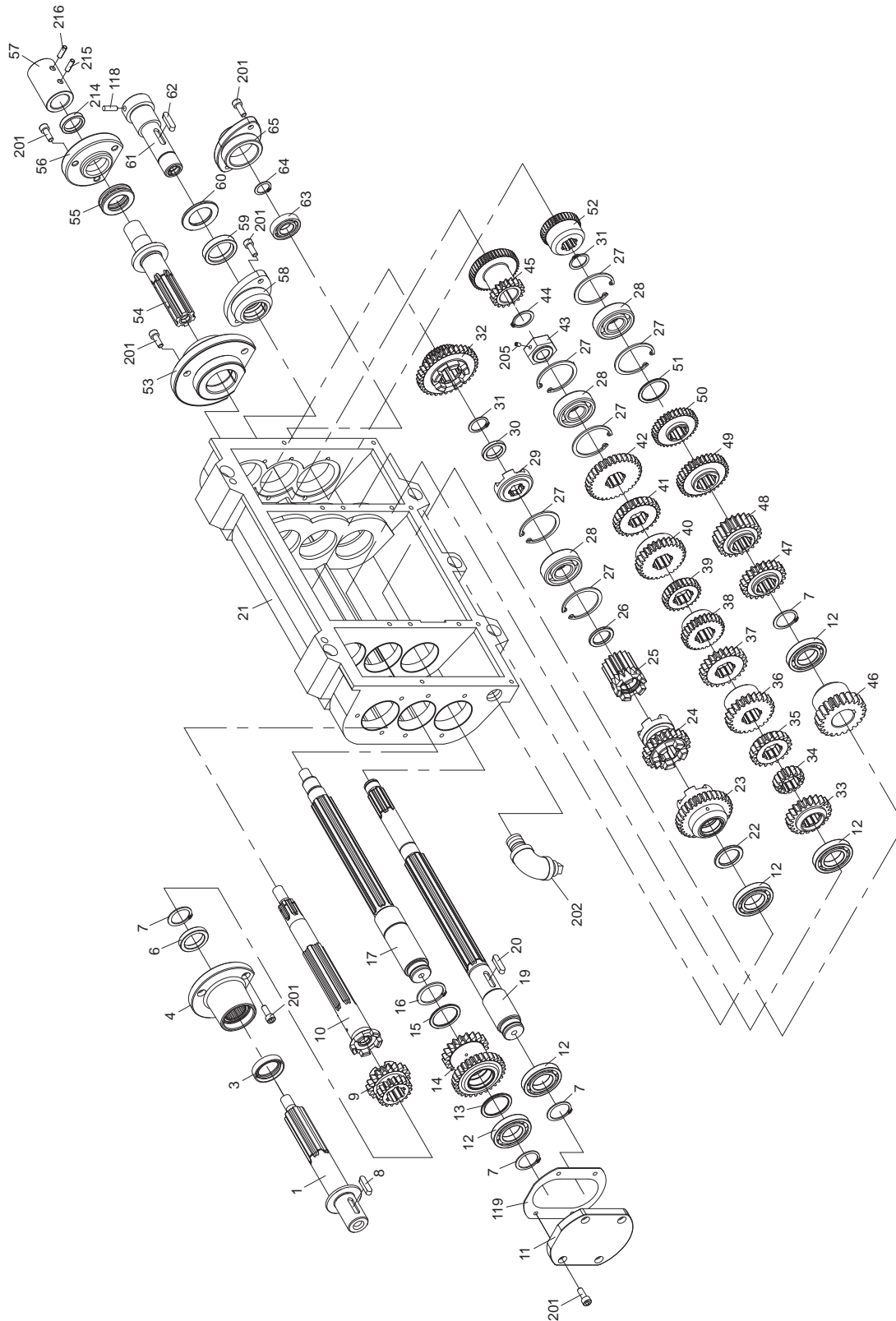

GEARBOX ASSEMBLY

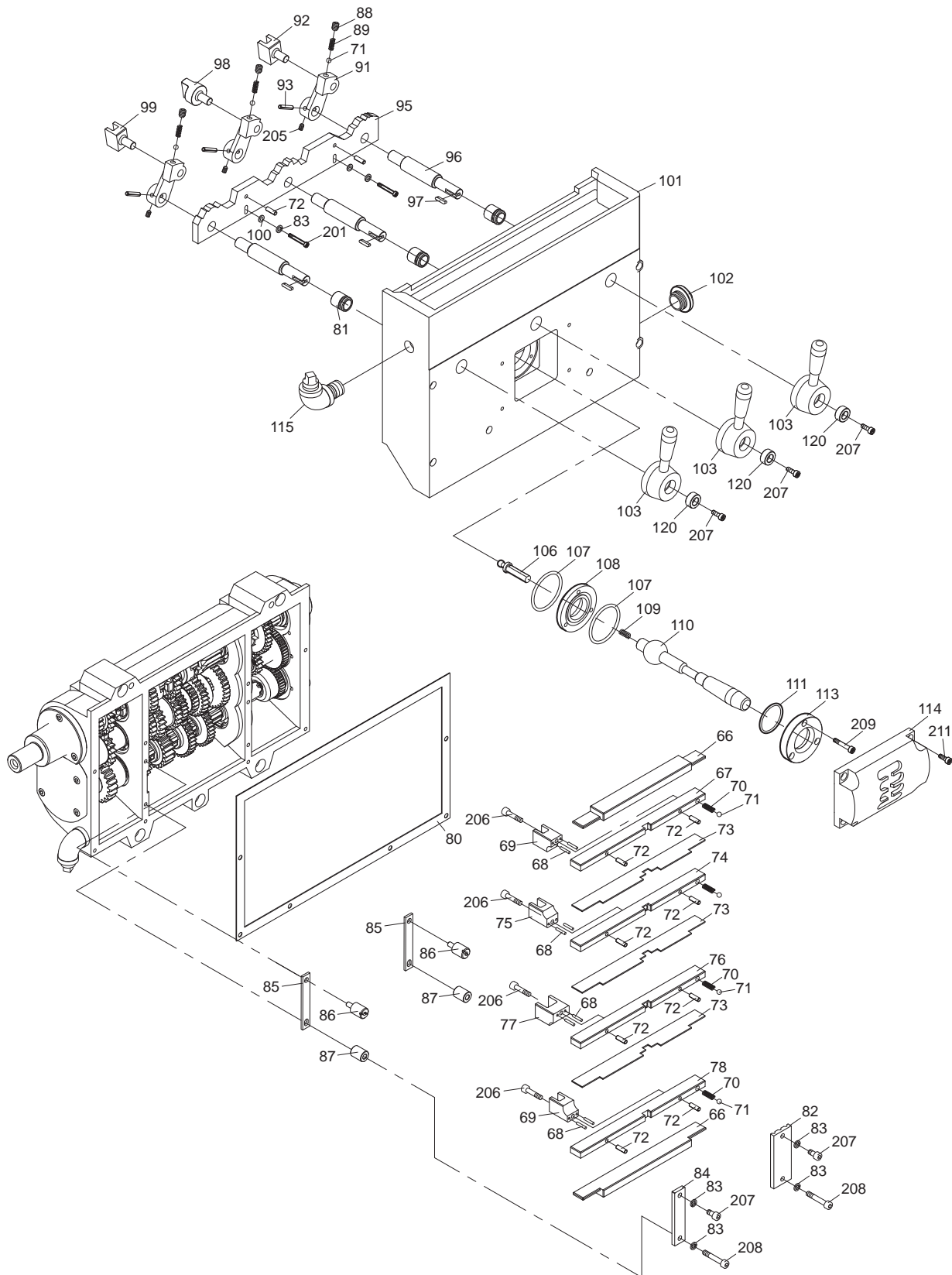



GEARBOX ASSEMBLY PARTS LIST

Index No.	Part No.	Description	Size	Qty.
1	EGH1740-B01	Shaft		1
3	EGH1740-B03	Oil Seal	25x37x08	1
4	EGH1740-B04	Bearing	TAF25/20	2
5	EGH1740-B05	Flanged Bearing		1
6	EGH1740-B06	Washer		1
7	EGH1740-B07	Clip	S25	4
8	EGH1740-B08	Key	7x7x30	1
9	EGH1740-B09	Gear	19T/19T	1
10	EGH1740-B10	Shaft		1
11	EGH1740-B11	Cover		1
12	BB-16005	Bearing	16005	5
13	EGH1740-B13	Washer		1
14	EGH1740-B14	Gear	30T/20T	1
15	EGH1740-B15	Washer		1
16	EGH1740-B16	Clip	S30	1
17	EGH1740-B17	Shaft		1
19	EGH1740-B19	Shaft		1
20	EGH1740-B20	Key	6x6x25	1
21	EGH1740-B21	Gearbox Body		1
22	EGH1740-B22	Washer		1
23	EGH1740-B23	Gear	32T	1
24	EGH1740-B24	Gear	23T	1
25	EGH1740-B25	Gear	16T	1
26	EGH1740-B26	Washer		1
27	EGH1740-B27	Clip	R47	6
28	BB-6204	Bearing	6204	3
29	EGH1740-B29	Clutch		1
30	EGH1740-B30	Washer		1
31	EGH1740-B31	Clip	S20	2
32	EGH1740-B32	Gear	35T	1
33	EGH1740-B33	Gear	22T	1
34	EGH1740-B34	Gear	16T	1
35	EGH1740-B35	Gear	20T	1
36	EGH1740-B36	Gear	24T	1
37	EGH1740-B37	Gear	23T	1
38	EGH1740-B38	Gear	27T	1
39	EGH1740-B39	Gear	24T	1
40	EGH1740-B40	Gear	28T	1
41	EGH1740-B41	Gear	26T	1
42	EGH1740-B42	Gear	32T	1
43	EGH1740-B43	Nut		1
44	EGH1740-B44	Clip	S22	1

Index No.	Part No.	Description	Size	Qty.
45	EGH1740-B45	Gear	18T/45T	1
46	EGH1740-B46	Gear	22T	1
47	EGH1740-B47	Gear	22T	1
48	EGH1740-B48	Gear	22T	1
49	EGH1740-B49	Gear	33T	1
50	EGH1740-B50	Gear	22T	1
51	EGH1740-B51	Washer		1
52	EGH1740-B52	Gear	36T	1
53	EGH1740-B53	Flanged Bearing		1
54	EGH1740-B54	Shaft		1
55	BB-51105	Bearing	51105	1
56	EGH1740-B56	Flanged Bearing		1
57	EGH1740-B57	Sleeve		1
58	EGH1740-B58	Flanged Bearing		1
59	EGH1740-B59	Oil seal	28x40x05	1
60	EGH1740-B60	Washer		1
61	EGH1740-B61	Shaft		1
62	EGH1740-B62	Key	5x5x35	1
63	BB-16003	Bearing	16003	1
64	EGH1740-B64	Clip	S17	1
65	EGH1740-B65	Flanged Bearing		1
66	EGH1740-B66	Upper Plate		2
67	EGH1740-B67	Fort Support		1
68	EGH1740-B68	Spring Pin	Ø3x16	8
69	EGH1740-B69	Fork		2
70	EGH1740-B70	Spring	Ø4x19	4
71	EGH1740-B71	Steel Ball	1/4"	7
72	EGH1740-B72	Spring Pin	Ø5x16	10
73	EGH1740-B73	Partition		3
74	EGH1740-B74	Fort Support		1
75	EGH1740-B75	Fork		1
76	EGH1740-B76	Fort Support		1
77	EGH1740-B77	Fork		1
78	EGH1740-B78	Fort Support		1
80	EGH1740-B80	Seal		1
81	EGH1740-B81	Spacer		3
82	EGH1740-B82	Reverse-Stop		1
83	TS-2361061	Spring Washer	M6	6
84	EGH1740-B84	Shoulder Plate		1
85	EGH1740-B85	Fixed Plate		2
86	EGH1740-B86	Partition Nut		2
87	EGH1740-B87	Spacer		2



Index No.	Part No.	Description	Size	Qty.
88	TS-1524011	Set Screw	SET 8x8	3
89	EGH1740-B89	Spring	Ø4x19	3
91	EGH1740-B91	Lever		3
92	EGH1740-B92	Fork		1
93	EGH1740-B93	Spring Pin	4x24	3
95	EGH1740-B95	Selector Bar		1
96	EGH1740-B96	Shaft		3
97	EGH1740-B97	Key	4x4x15	3
98	EGH1740-B98	Fork		1
99	EGH1740-B99	Fork		1
100	TS-1550041	Washer	M6	2
101	EGH1740-B101	Gearbox Cover		1
102	EGH1740-B102	Oil Sight		1
103	EGH1740-B103	Hub & Handle Assembly		3
106	EGH1740-B106	Selector Lever		1
107	EGH1740-B107	O-Ring	G40	2
108	EGH1740-B108	Selector Lever Support		1
109	EGH1740-B109	Spring	9x38	1
110	EGH1740-B110	Selector Lever		1
111	EGH1740-B111	O-Ring	G30	1
113	EGH1740-B113	Selector Lever Cover		1
114	EGH1740-B114	Specifying Base		1
115	EGH1740-B115	Square Head Plug	3/4"	1
116	EGH1740-B116	Elbow	3/4"	1
117	EGH1740-B117	Nipple	3/4"x1"	1
118	EGH1740-B118	Pin	Ø6x36	1
119	EGH1740-B119	Seal		1
120	EGH1760-B120	Washer		3
201	TS-1503041	Hex. Socket Head Bolt	CAP 6x16	17
202	EGH1740-B202	Square Head Plug	1/4"	1
203	EGH1740-B203	Elbow	1/4"	1
204	EGH1740-B204	Nipple	1/4"x1"	1
205	TS-152301	Set Screw	SET 6x6	4
206	TS-1502051	Hex. Socket Head Bolt	CAP 5x20L	4
207	TS-1503041	Hex. Socket Head Bolt	CAP 6x16	5
208	TS-1503091	Hex. Socket Head Bolt	CAP 6x40	2
209	TS-1503061	Hex. Socket Head Bolt	CAP 6x25	3
211	TS-1503031	Hex. Socket Head Bolt	CAP 6x12	4
214	EGH1740-B214	Oil Seal	24x35x08	1
215	EGH1740-B215	Pin	#4x32	1
216	EGH1740-B216	Shear Pin	#4x32	1

APRON (L.H) ASSEMBLY

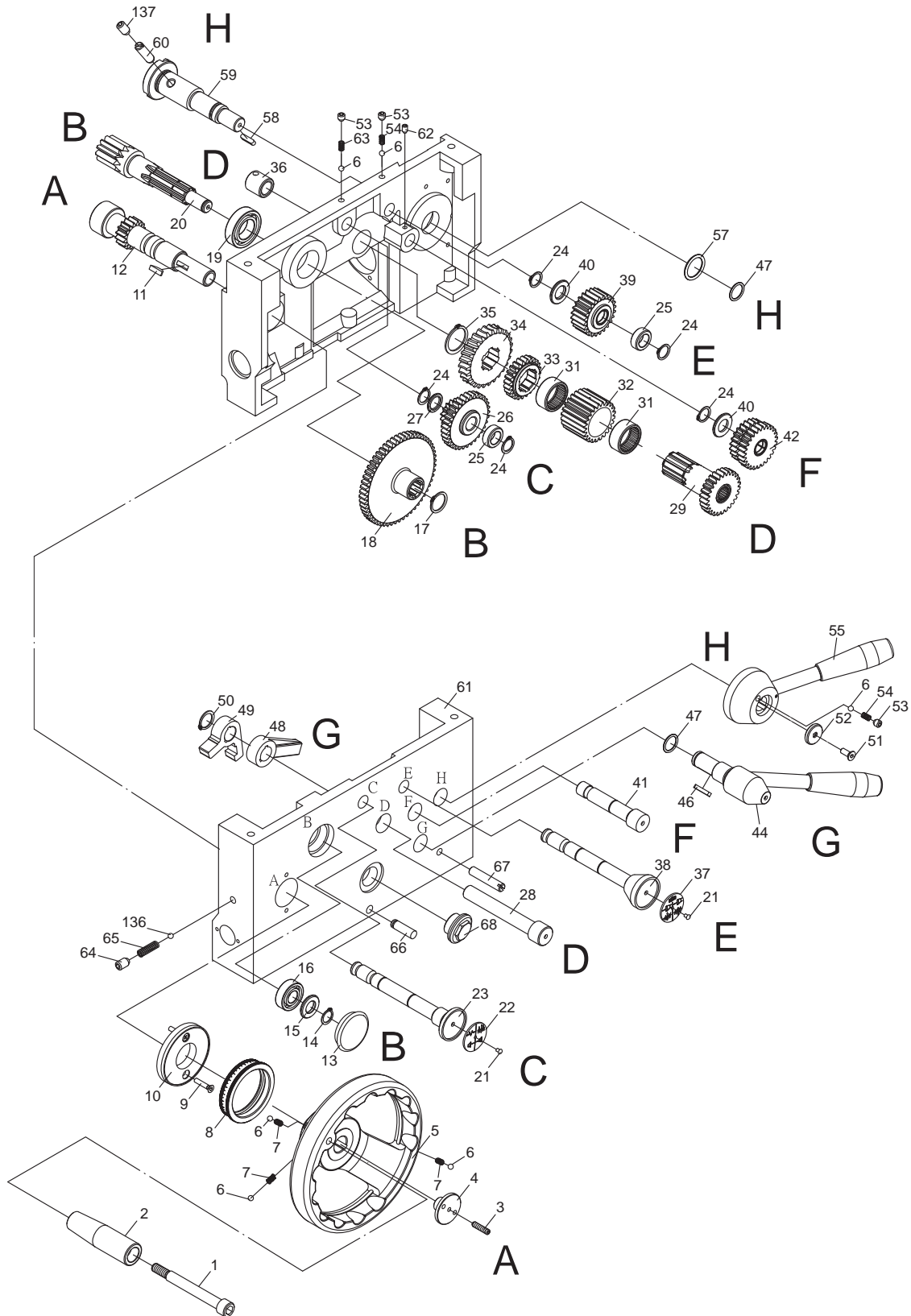

APRON (L.H) ASSEMBLY

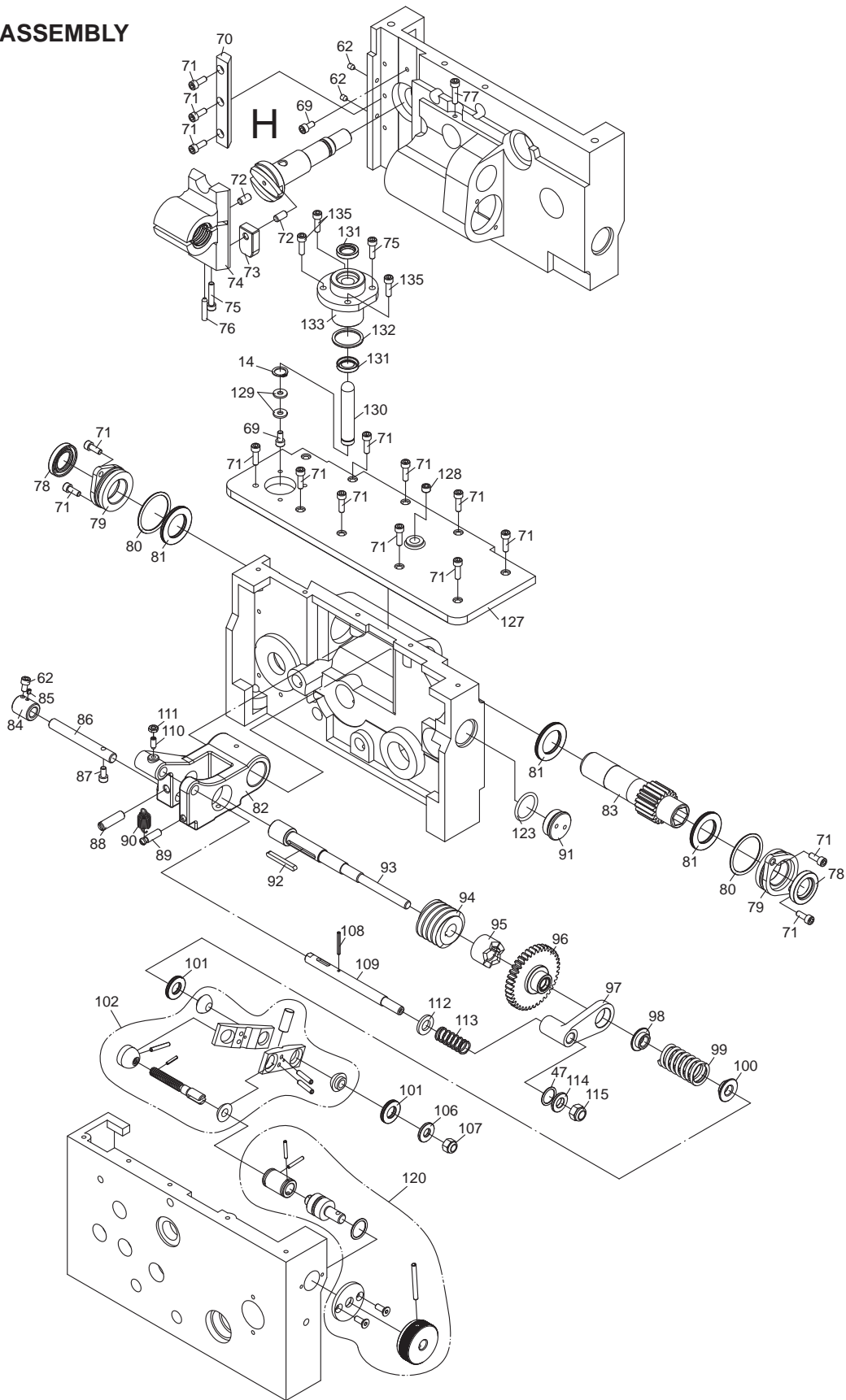

APRON (L.H) ASSEMBLY PARTS LIST

Index No.	Parts No.	Description	Size	Qty.
1	EGH1740-C01	Screw		1
2	EGH1740-C02	Handle		1
3	TS-1523071	Set Screw	SET 6x25	1
4	EGH1740-C04	Bolt		1
5	EGH1740-C05	Hand Wheel		1
6	EGH1740-C06	Steel Ball	1/4"	6
7	EGH1740-C07	Spring		3
8	EGH1740-C08	Index Ring		1
9	TS-1513021	Flat Hexagon Screw	5x12	2
10	EGH1740-C10	Shaft Liner		1
11	EGH1740-C11	Woodruff Key	5x19	1
12	EGH1740-C12	Gear Shaft	(A)	1
13	EGH1740-C13	Plug		1
14	EGH1740-C14	Snap Ring	S15	2
15	EGH1740-C15	Collar		1
16	BB-6202	Ball Bearing	6202LR	1
17	EGH1740-C17	Snap Ring	S22	1
18	EGH1740-C18	Gear	56T	1
19	BB-6005	Ball Bearing	6005LU	1
20	EGH1740-C20	Gear Shaft	(B)	1
21	EGH1740-C21	Rivet	2.8x10	2
22	EGH1740-C22	Name Plate		1
23	EGH1740-C23	Shaft	C	1
24	EGH1740-C24	Snap Ring	S16	5
25	EGH1740-C25	Collar		2
26	EGH1740-C26	Gear	15T/33T	1
27	EGH1740-C27	Collar		1
28	EGH1740-C28	Shaft	D	1
29	EGH1740-C29	Needle Bearing & Gear Shaft Assembly		2
31	EGH1740-C31	Needle Bearing	TLA3016	2
32	EGH1740-C32	Gear	24T	1
33	EGH1740-C33	Gear	24T	1
34	EGH1740-C34	Worm Wheel		1
35	EGH1740-C35	Snap Ring	S30	1
36	EGH1740-C36	Collar	D	1
37	EGH1740-C37	Name Plate		1
38	EGH1740-C38	Shaft	E	1
39	EGH1740-C39	Gear	24T	1
40	EGH1740-C40	Collar		2
41	EGH1740-C41	Shaft	F	1
42	EGH1740-C42	Gear	24T/26T	1
44	EGH1740-C44	Spring Pin, Handle, Sleeve Assembly		1
46	EGH1740-C46	Key	4x4x25	1



Index No.	Parts No.	Description	Size	Qty.
47	EGH1740-C47	O Ring	P18	3
48	EGH1740-C48	Pad		1
49	EGH1740-C49	Elasticity Pole		1
50	EGH1740-C50	Snap Ring	S18	1
51	TS-1514021	Flat Hexagon Screw	6x16	1
52	EGH1740-C52	Washer		1
53	TS-1524011	Set Screw	SET8x8	3
54	EGH1740-C54	Spring		2
55	EGH1740-C55	Lead Nut Lever, Handle , Spring Pin	Assembly	1
57	EGH1740-C57	O Ring	P21	1
58	EGH1740-C58	Key	5x18	1
59	EGH1740-C59	Cam Shaft		1
60	EGH1740-C60	Set Screw	SET 10x40	1
61	EGH1740-C61	Apron		1
62	TS-2276081	Set Screw	SET 6x8	4
63	EGH1740-C63	Spring		1
64	TS-1525031	Set Screw	SET 10x16	1
65	EGH1740-C65	Spring		2
66	EGH1740-C66	Pin		1
67	EGH1740-C67	Pin		1
68	EGH1740-C68	Oil Sight		1
69	TS-1503031	Hexagon Socket Head Bolt	CAP 6x12	2
70	EGH1740-C70	Adjust Plate		1
71	TS-1503041	Hexagon Socket Head Bolt	CAP6x16	16
72	EGH1740-C72	Pin		2
73	EGH1740-C73	Slide Plate		1
74	EGH1740-C74	Half Nut		1
75	TS-1503071	Hexagon Socket Head Bolt	CAP 6x30	2
76	EGH1740-C76	Set Screw	SET 6x30	1
77	TS-1503061	Hexagon Socket Head Bolt	CAP 6x25	1
78	EGH1740-C78	Oil Seal	30x40x5	2
79	EGH1740-C79	Sleeve		2
80	EGH1740-C80	O Ring	G40	2
81	EGH1740-C81	Thrust Bearing	NTB3047/AS2	3
82	EGH1740-C82	Bracket		1
83	EGH1740-C83	Pinion		1
84	EGH1740-C84	Spacer		1
85	EGH1740-C85	Spring Pin	4x20	1
86	EGH1740-C86	Pin		1
87	TS-1502061	Hexagon Socket Head Bolt	CAP 5x25	1
88	EGH1740-C88	Pin		1
89	EGH1740-C89	Pin		1

Index No.	Parts No.	Description	Size	Qty.
90	EGH1740-C90	Spring		1
91	EGH1740-C91	Nut		1
92	EGH1740-C92	Key	5x5x45	1
93	EGH1740-C93	Shaft		1
94	EGH1740-C94	Worm		1
95	EGH1740-C95	Clutch		1
96	EGH1740-C96	Clutch Gear		1
97	EGH1740-C97	Lever Arm		1
98	EGH1740-C98	Washer		1
99	EGH1740-C99	Spring		1
100	EGH1740-C100	Washer		1
101	EGH1740-C101	Thrust Bearing	NTB1528/AS2	2
102	EGH1740-C102	Flanged Bearing Assembly		2
106	EGH1740-C106	Washer		1
107	TS-1541041	Nylon Jam Nut	M10	1
108	EGH1740-C108	Spring Pin	4x24	1
109	EGH1740-C109	Trip Rod		1
110	TS-1523051	Set Screw	SET 6x16	1
111	TS-1541021	Nylon Jam Nut	M6	1
112	EGH1740-C112	Washer		1
113	EGH1740-C113	Spring		1
114	EGH1740-C114	Washer		1
115	TS-2342121	Nylon Jam Nut	M12	1
120	EGH1740-C120	Flat Hexagon Screw Assembly		2
123	EGH1740-C123	O Ring	P21	1
127	EGH1740-C127	Plate		1
128	EGH1740-C128	Hexagon Socket Head Plug	PT1/4"	1
129	EGH1740-C129	Washer		2
130	EGH1740-C130	Shaft		1
131	EGH1740-C131	Oil Seal	TC15255A	2
132	EGH1740-C132	O Ring	P30	1
133	EGH1740-C133	Bush		1
135	TS-1503051	Hexagon Socket Head Bolt	CAP6x20	3
136	EGH1740-C136	Steel Ball	3/8"	1
137	TS-1525011	Set Screw	SET 10x10	1

DIAL INDICATOR ASSEMBLY & PARTS LISTS IMPERIAL (LEADSCREW 4 T.P.I)

Index No.	Part No.	Description	Size	Qty.
1	EGH1740-D01	Pilot Plate		1
2	EGH1740-D02	Gear Pivot		1
3	EGH1740-D03	Body		1
4	EGH1740-D04	Nut		1
5	EGH1740-D05	Stud		1
6	EGH1740-D06	Threading Plate		1
7	EGH1740-D07	Spacer		1
8	EGH1740-D08	Dial Gear	16T	1
51	TS-1503021	Hex. Socket Head Bolt	M6x10L	1
52	EGH1740-D52	Rivet		4
53	TS-1523011	Set Screw	M6x6L	1
54	TS-2331081	Hexagon Nut	M8	1

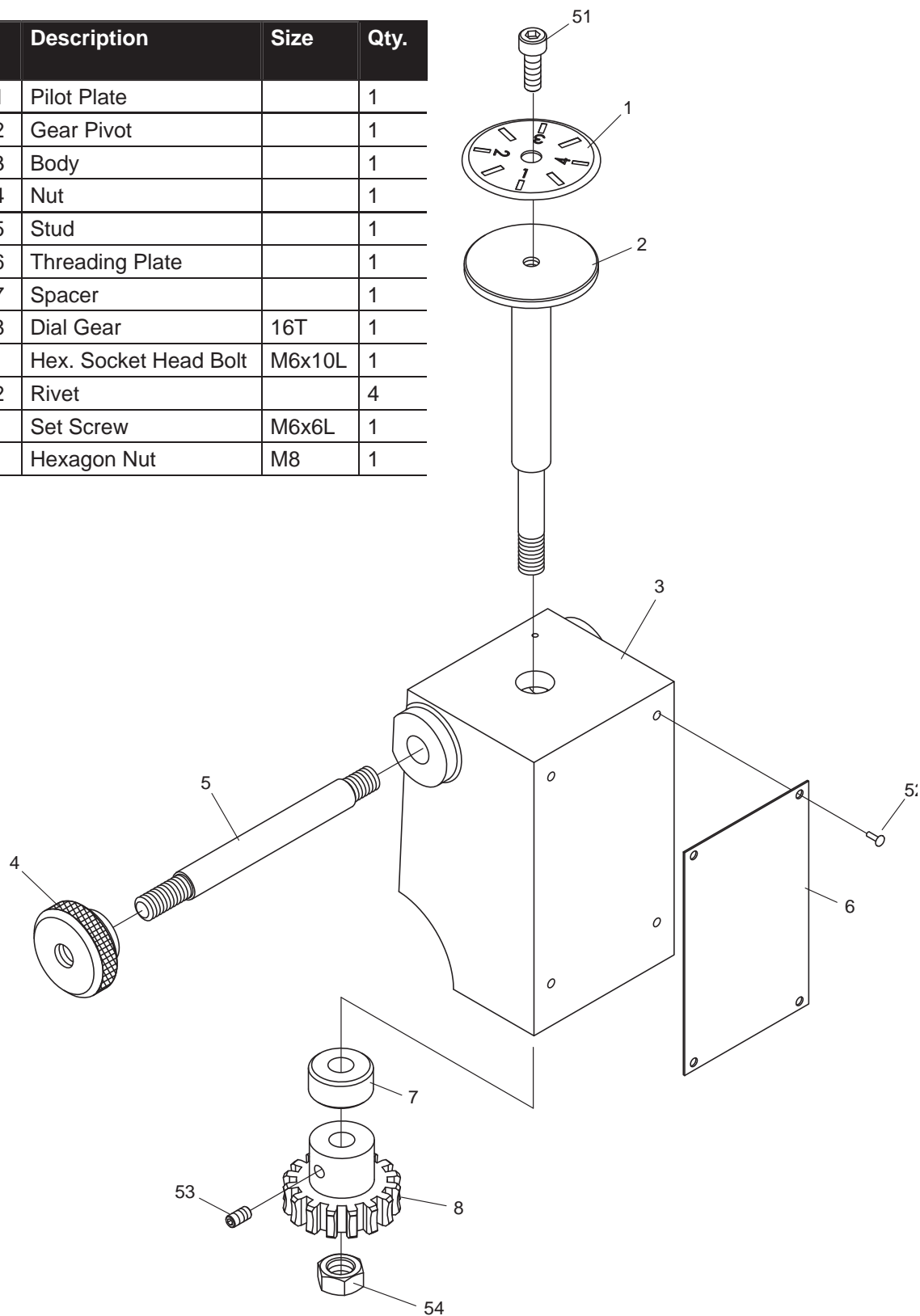

4 WAY TOOL POST

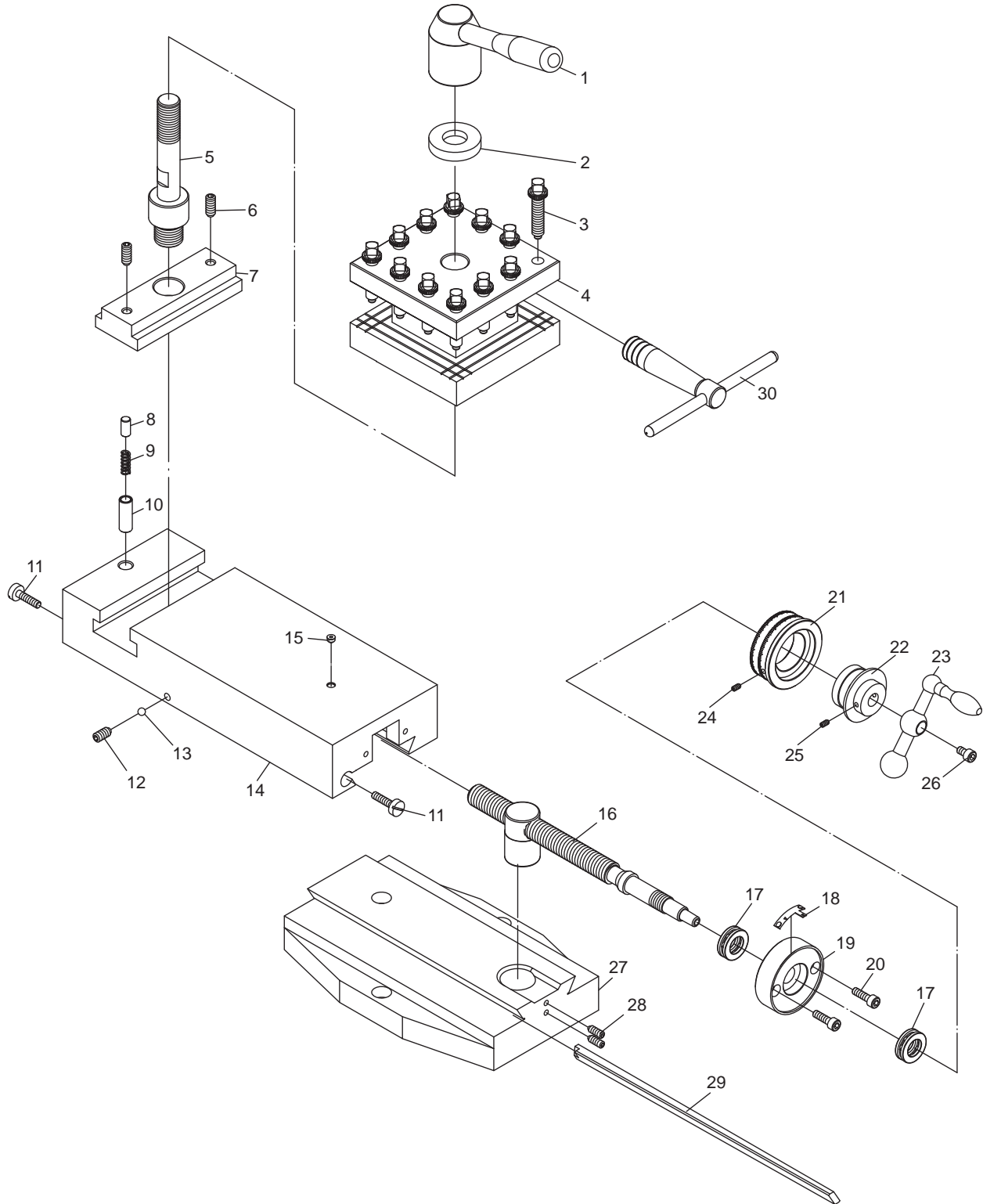



4 WAY TOOL POST PARTS LIST

Index No.	Parts No.	Description	Size	Qty.
1	EGH1740-E01	Handle & Turret Nut	Assembly for replacement	1
2	EGH1740-E02	Collar		1
3	EGH1740-E03	Bolt		12
4	EGH1740-E04	Turret Body		1
5	EGH1740-E05	Turret Shaft		1
6	TS-1524051	Set Screw	SET 8x20	2
7	EGH1740-E07	Nut		1
8	EGH1740-E08	Pin		1
9	EGH1740-E09	Spring		1
10	EGH1740-E10	Bush		1
11	EGH1740-E11	Screw		2
12	TS-1524041	Set Screw	SET 8x16	1
13	EGH1740-E13	Steel Ball	1/4"	1
14	EGH1740-E14	Solid Topslide		1
15	EGH1740-E15	Oil Ball	1/4"	1
16	EGH1740-E16	Nut & Screw	Assembly for replacement	1
17	BB-51102	Trust Bearing	51102	2
18	EGH1740-E18	Curve Pilot		1
19	EGH1740-E19	Keep Ass'y		1
20	TS-1503051	Hex. Socket Head Bolt	CAP 6x20	2
21	EGH1740-E21	Dial Ring		1
22	EGH1740-E22	Bush		1
23	EGH1740-E23	Handle		1
24	TS-1522031	Set Screw	SET 5x10	1
25	TS-1522011	Set Screw	SET 5x6	1
26	TS-1503041	Hex. Socket Head Bolt	CAP 6x16	1
27	EGH1740-E27	Swivel		1
28	TS-1523061	Set Screw	SET 6x20	2
29	EGH1740-E29	Gib		1
30	EGH1740-E30	T Wrench		1

SADDLES ASSEMBLY

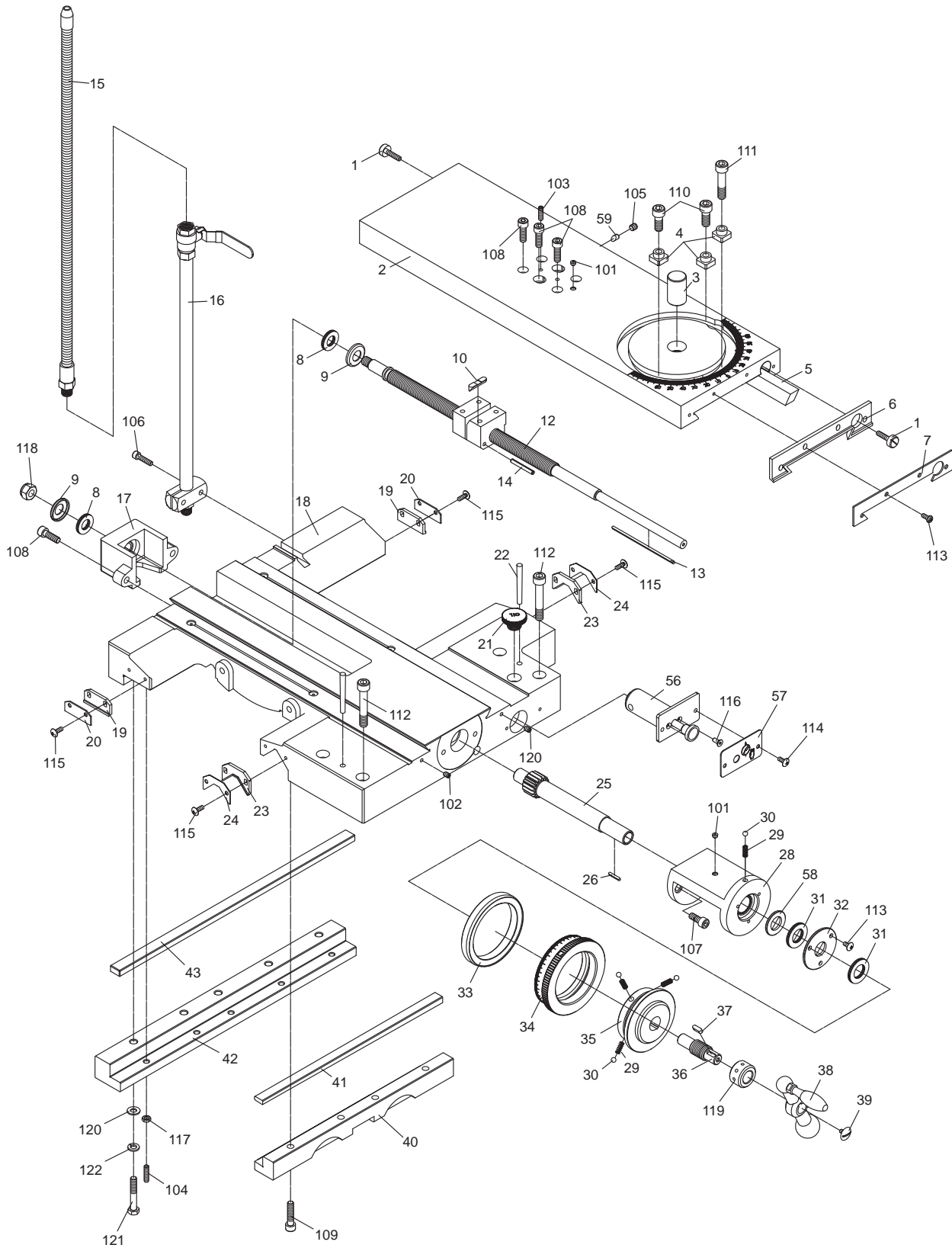

SADDLES ASSEMBLY 2

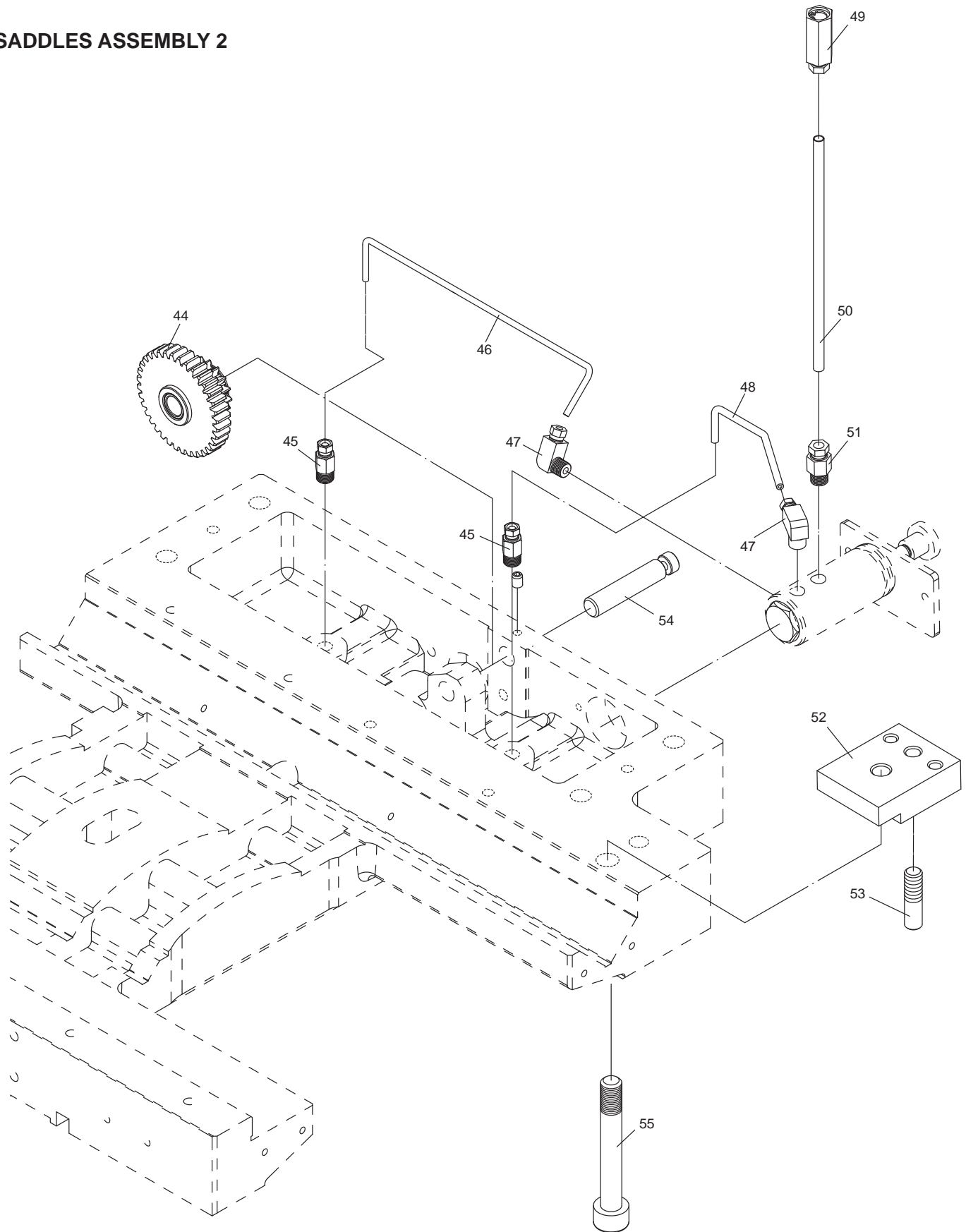

SADDLES ASSEMBLY PARTS LIST

Index No.	Parts No.	Description	Size	Qty.
1	EGH1740-F01	Adjust Screw		2
2	EGH1740-F02	Cross Slide		1
3	EGH1740-F03	Pivot	Ø25x40	1
4	EGH1740-F04	T bolt		3
5	EGH1740-F05	Gib-X		1
6	EGH1740-F06	Wiper-X		1
7	EGH1740-F07	Plate -X		1
8	EGH1740-F08	Thrust Bearing	NTB/AS2 1528	2
9	EGH1740-F09	Cap Collar		2
10	EGH1740-F10	Pin		1
12	EGH1740-F12	Lead Screw & Nut	Assembly for replacement	1
13	EGH1740-F13	Key	3x3x115	1
14	EGH1740-F14	Spring Pin	Ø5x40	2
15	EGH1740-F15	Spraying Pipe	PT3/8 x 24"	1
16	EGH1740-F16	Valve & Junction Assy.	PT3/8	1
17	EGH1740-F17	Bracket		1
18	EGH1740-F18	Saddle		1
19	EGH1740-F19	Wiper F		2
20	EGH1740-F20	Plate F		2
21	EGH1740-F21	Oil Cover	NF3/4"	1
22	EGH1740-F22	Taper Pin	#6x70L	2
23	EGH1740-F23	Wiper V		2
24	EGH1740-F24	Plate V		2
25	EGH1740-F25	Gear	16T	1
26	EGH1740-F26	Key	3x3x20	1
28	EGH1740-F28	Keep Assy.		1
29	EGH1740-F29	Spring	Ø6x15 L	4
30	EGH1740-F30	Steel Ball	1/4"	4
31	EGH1740-F31	Thrust Bearing	NTB/AS2 2035	2
32	EGH1740-F32	Washer		1
33	EGH1740-F33	Dial ring		1
34	EGH1740-F34	Dual (ENG)		1
35	EGH1740-F35	Bush		1
36	EGH1740-F36	Shaft		1
37	EGH1740-F37	Key	5x5x20	1
38	EGH1740-F38	Hand Wheel & Handle	Assembly for replacement	
39	EGH1740-F39	Screw		1
40	EGH1740-F40	Front Anti-Floater		1
41	EGH1740-F41	Gib-Z		1
42	EGH1740-F42	Front Anti-Floater		1
43	EGH1740-F43	Gib-Y		1



Index No.	Parts No.	Description	Size	Qty.
44	EGH1740-F44	Gear	16T/36T	1
45	EGH1740-F45	Straight Adapter	1/8xØ4	2
46	EGH1740-F46	Al. Tube	Ø4x258	1
47	EGH1740-F47	Elbow Adapter	1/8x Ø4	2
48	EGH1740-F48	Al. Tube	Ø4x121	1
49	EGH1740-F49	Oil Filter	Ø6	1
50	EGH1740-F50	Al. Tube	Ø6x170	1
51	EGH1740-F51	Straight Adapter	1/8x Ø6	2
52	EGH1740-F52	Clamp Plate		1
53	EGH1740-F53	Bolt		1
54	EGH1740-F54	Short Shaft		1
55	EGH1740-F55	Hex. Socket Head Bolt	CAP12x85	1
56	EGH1740-F56	Lubricator Assy.		1
57	EGH1740-F57	Plate		1
58	EGH1740-F58	Washer		1
59	EGH1740-F59	Block		1
101	EGH1740-F101	Oil Ball	1/4"	2
102	TS-1523021	Set Screw	SET 6x8	2
103	TS-1523061	Set Screw	SET 6x20	1
104	TS-1523071	Set Screw	SET 6x25	5
105	TS-1524011	Set Screw	SET 8x8	1
106	TS-1503061	Hex. Socket Head Bolt	CAP 6x25	2
107	TS-1504041	Hex. Socket Head Bolt	CAP 8x20	2
108	TS-1504051	Hex. Socket Head Bolt	CAP 8x25	8
109	TS-1504071	Hex. Socket Head Bolt	CAP 8x35	4
110	TS-1505031	Hex. Socket Head Bolt	CAP 10x25	2
111	TS-1505071	Hex. Socket Head Bolt	CAP 10x45	1
112	TS-1505101	Hex. Socket Head Bolt	CAP 10x60	4
113	TS-1534041	Dome Cross Screw	M5x10	3
114	TS-2285121	Dome Cross Screw	M5x12	2
115	EGH1740-F115	Dome Cross Screw	M5x15	4
116	TS-1513021	Flat Hexagon Screw	M5x12	2
117	TS-2331061	Nut	M6	5
118	TS-2342101	Nut	M10	1
119	EGH1740-F119	Nut		1
120	TS-1550061	Washer	M8	5
121	TS-1504101	Hexagon Head Bolt	M8x50	5
122	TS-2361081	Spring Washer	M8	5

BED AND SHAFTS ASSEMBLY

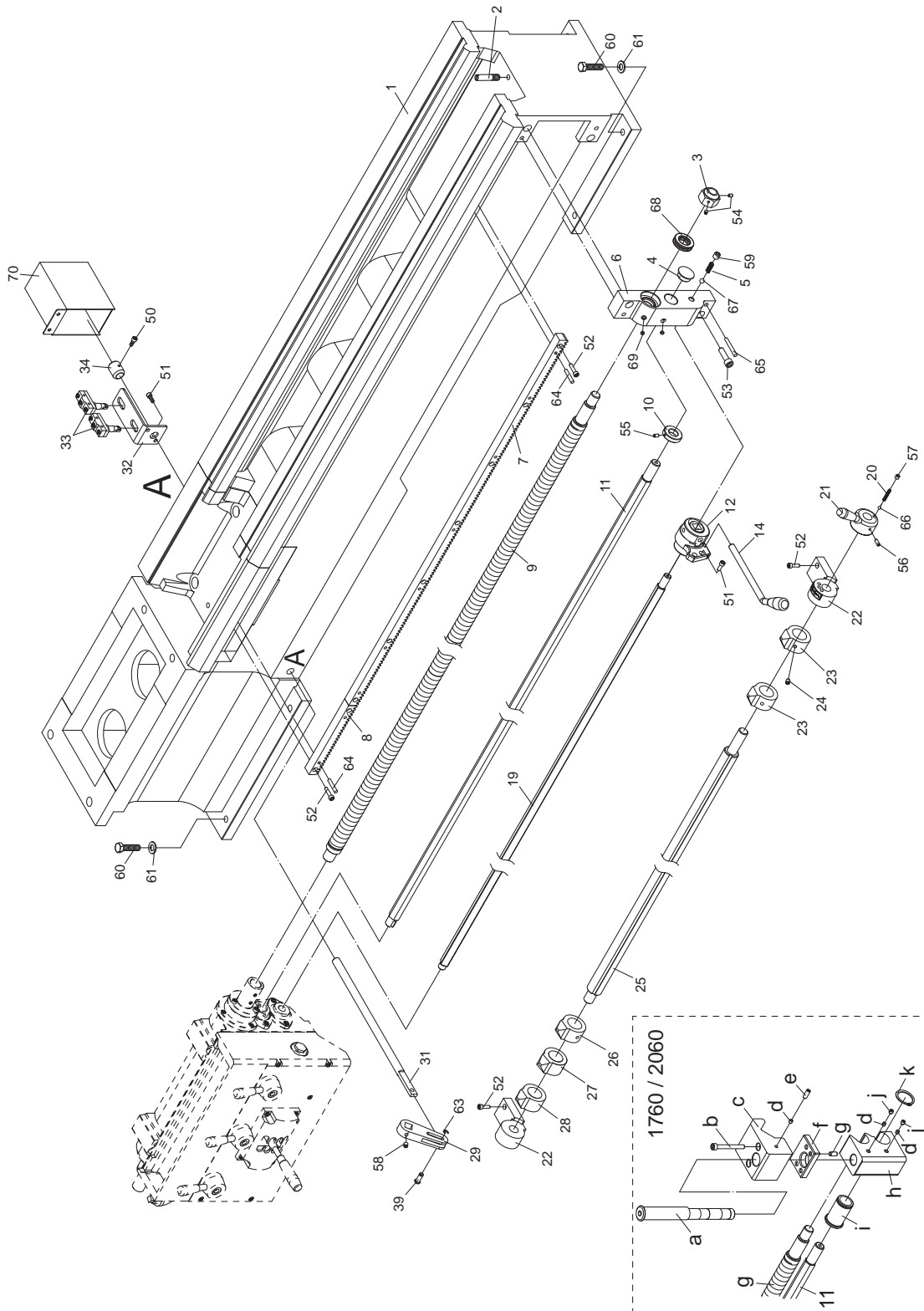



BED AND SHAFTS ASSEMBLY PARTS LIST

Index No.	Parts No.	Description	Size	Qty.
1	EGH1740-G01	Bed		1
	EGH1760-G01	Bed		1
2	EGH1740-G02	Bolt		1
3	EGH1740-G03	Nut		1
4	EGH1740-G04	Plug		1
5	EGH1740-G05	Spring		1
6	EGH1740-G06	Bracket		1
7	EGH1740-G07	Rack		1
	EGH1760-G07	Rack		1
8	EGH1740-G08	Rack		1
9	EGH1740-G09	Lead Screw		1
	EGH1760-G09	Lead Screw		1
10	EGH1740-G10	Collar		1
11	EGH1740-G11	Feed Rod		1
	EGH1760-G11	Feed Rod		1
12	EGH1740-G12	Lever Assy		1
13	EGH1740-G13	Pin		2
14	EGH1740-G14	Knob & Handle	Assembly for replacement	1
15	EGH1740-G15	Bracket		1
16	EGH1740-G16	Sleeve		1
17	EGH1740-G17	Spring		1
18	EGH1740-G18	Spring Cover		1
19	EGH1740-G19	Spindle Control Shaft		1
	EGH1760-G19	Spindle Control Shaft		1
20	EGH1740-G20	Spring		1
21	EGH1740-G21	Handle Base		1
22	EGH1740-G22	Bracket		2
23	EGH1740-G23	Dog		2
24	EGH1740-G24	Screw		5
25	EGH1740-G25	Rod		1
	EGH1760-G25	Rod		1
26	EGH1740-G26	Dog		1
27	EGH1740-G27	Dog		1
28	EGH1740-G28	Dog		1
29	EGH1740-G29	Connecting Rod		1
30	EGH1740-G30	Pin		1
31	EGH1740-G31	Connecting Rod		1

Index No.	Parts No.	Description	Size	Qty.
32	EGH1740-G32	Switch Base		1
33	EGH1740-G33	Limit Switch	TM1308	2
34	EGH1740-G34	Collar		1
50	TS-1503031	Hex. Socket Head Bolt	CAP 6x12	1
51	TS-1503041	Hex. Socket Head Bolt	CAP 6x16	4
52	TS-1503051	Hex. Socket Head Bolt	CAP 6x20	13
53	TS-1505051	Hex. Socket Head Bolt	CAP 10x35	2
54	TS-1523021	Set Screw	SET 6x8	2
55	TS-1523031	Set Screw	SET 6x10	1
56	TS-1523051	Set Screw	SET 6x16	1
57	TS-1524011	Set Screw	SET 8x8	1
58	TS-1524021	Set Screw	SET 8x10	1
59	TS-1526011	Set Screw	SET 12x12	1
60	TS-1506071	Hexagon Head Bolt	M12x50	8
61	TS-2360121	Washer	M12	8
62	EGH1740-G62	Clip	S32	1
63	EGH1740-G63	Snap Ring	E6	1
64	EGH1740-G64	Pin	Ø6x25	8
65	EGH1740-G65	Pin	Ø6x50	2
66	EGH1740-G66	Steel Ball	1/4"	1
67	EGH1740-G67	Steel Ball	3/8"	1
68	BB-51105	Thrust Bearing	51105	2
69	EGH1740-G69	Oil Ball	1/4"	2
70	EGH1740-G70	Block Oil Plate		1
a	EGH1760-G0a	Shaft		1
b	TS-1504131	Hex. Socket Head Bolt	CAP 8x70	2
c	EGH1760-G0c	Block		1
d	EGH1760-G0d	Pin		3
e	TS-1524051	Set Screw	SET 8x20	1
f	EGH1760-G0f	Block		1
g	TS-1524041	Set Screw	SET 8x16	1
h	EGH1760-G0h	Bracket		2
i	EGH1760-G0i	Barrel		1
j	TS-1524011	Set Screw	SET 8x8	1
k	EGH1760-G0k	Clip	S35	1

END GEAR ASSEMBLY

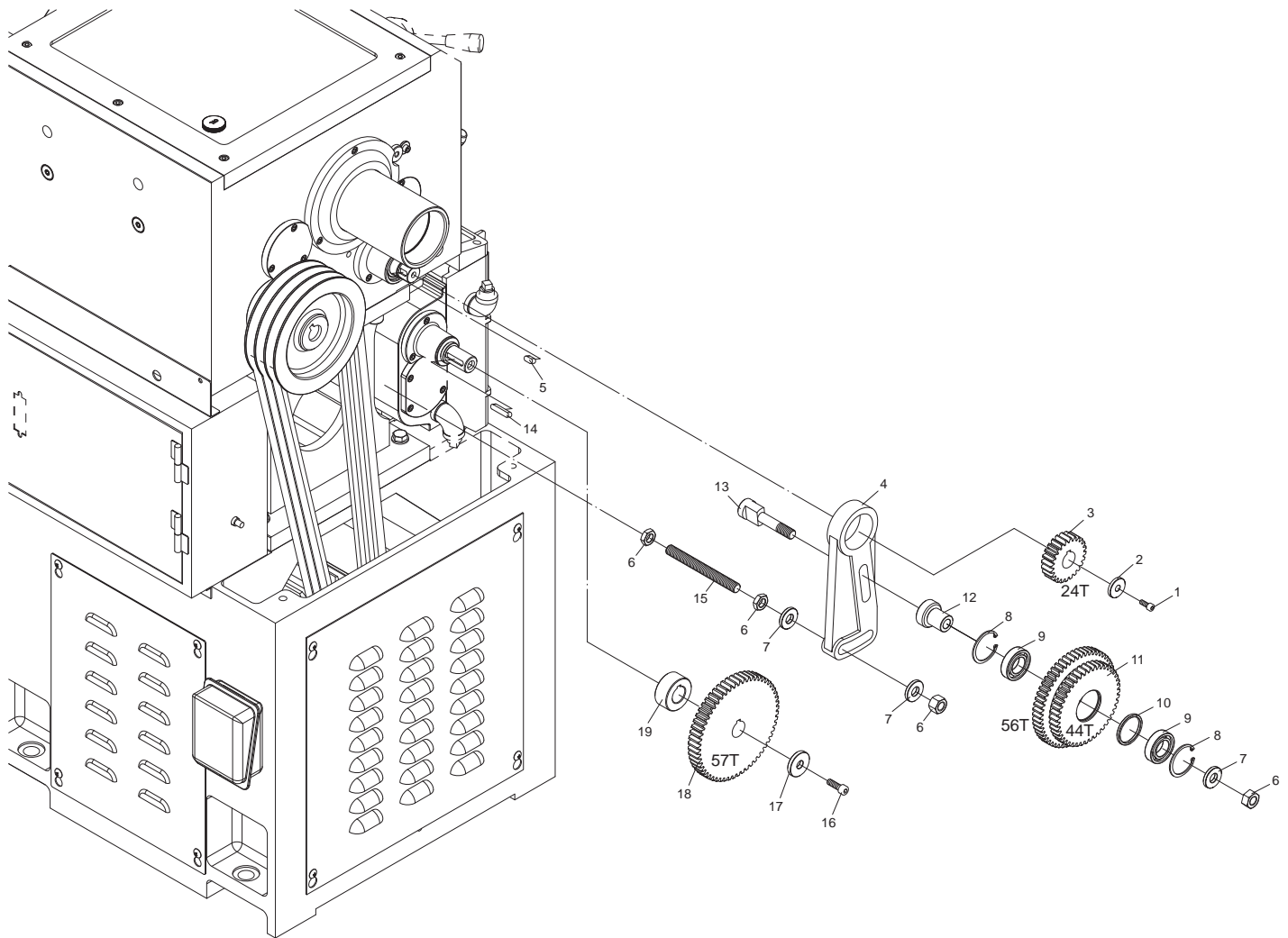

END GEAR ASSEMBLY PARTS LIST

Index No.	Parts No.	Description	Size	Qty.
1	EGH1740-H01	Hex. Socket Head Bolt	CAP 6x15	1
2	EGH1740-H02	Washer		1
3	EGH1740-H03	Gear	24T	1
4	EGH1740-H04	Swing Frame		1
5	EGH1740-H05	Key	7x7x15	1
6	TS-154009	Nut	M14	4
7	EGH1740-H07	Washer		3
8	EGH1740-H08	Clip	R47	2
9	BB-6005Z	Ball bearing	6005Z	2
10	EGH1740-H10	Collar		1
11	EGH1740-H11	Gear	44T/56T	1
12	EGH1740-H12	Shaft		1
13	EGH1740-H13	Shaft		1
14	EGH1740-H14	Key	7x7x35	1
15	EGH1740-H15	Bolt	M14x135	1
16	EGH1740-H16	Hex. socket head bolt	CAP 8x15	1
17	EGH1740-H17	Washer		1
18	EGH1740-H18	Gear	54T	1
19	EGH1740-H19	Collar		1

MAIN MOTOR ASSEMBLY

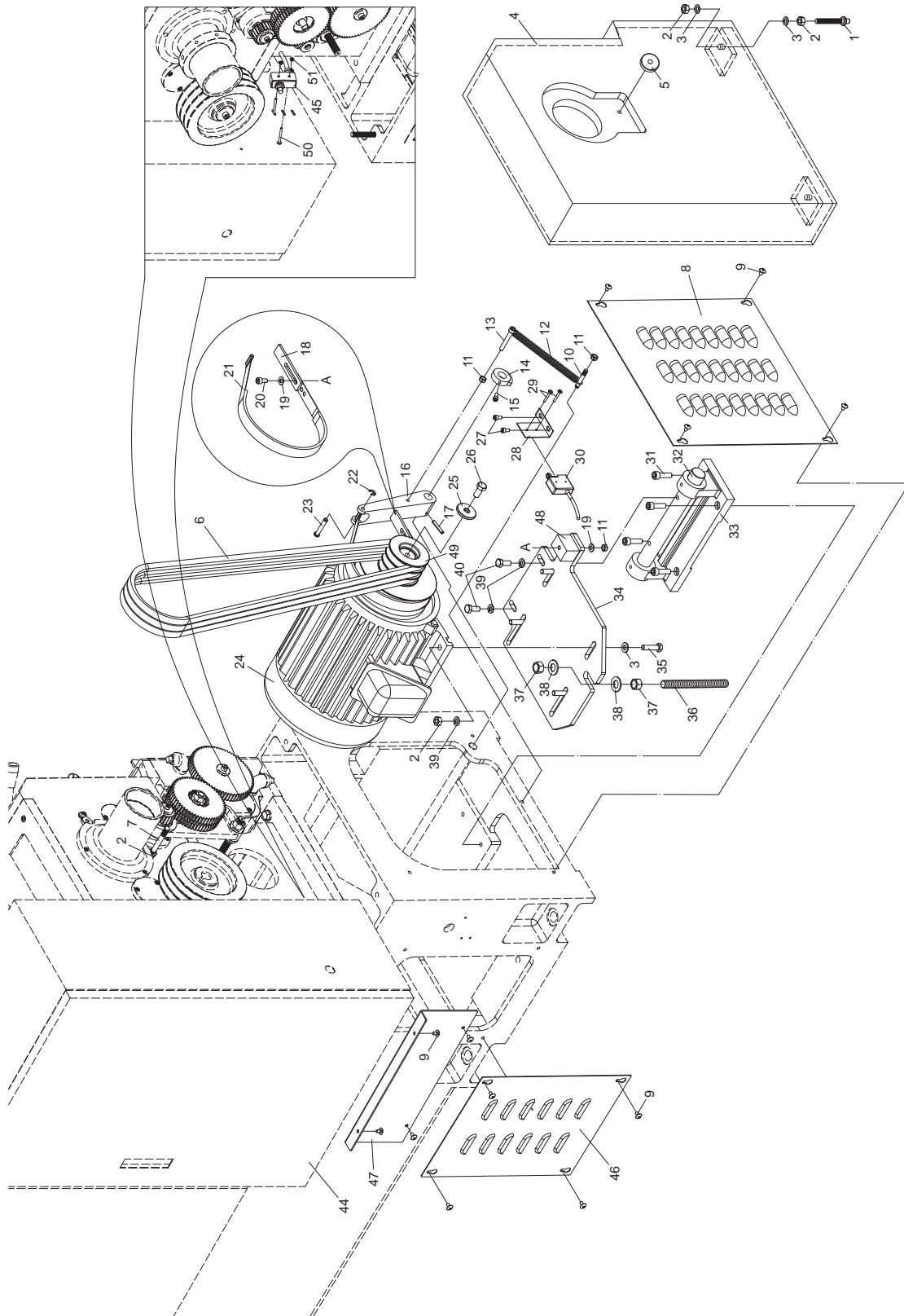

MAIN MOTOR ASSEMBLY PARTS LIST

Index No.	Parts No.	Description	Size	Qty.
1	EGH1740-I01	Pin		2
2	TS-2331101	Nut	M10	9
3	TS-1550071	Washer	M10	9
4	EGH1740-I04	Cover		1
5	EGH1740-I05	Nut		1
6	EGH1740-I06	V belt	50Z B72 & 60Z B71	3
7	EGH1740-I07	Bolt		1
8	EGH1740-I08	Cover		1
9	TS-1534032	Dome Cross Screw	6x10	12
10	EGH1740-I10	Bolt		1
11	TS-2331081	Nut	M8	3
12	EGH1740-I12	Spring		1
13	TS-1504111	Hex. Socket Head Bolt	CAP 8x55	1
14	EGH1740-I14	Cam		1
15	EGH1740-I15	Hex. Socket Head Bolt	CAP6x15	1
16	EGH1740-I16	Lever		1
17	EGH1740-I17	Spring Pin	Ø6x35	1
18	EGH1740-I18	Fixed Plate		1
19	TS-1550061	Washer	M8	2
20	EGH1740-I20	Hex. Socket Head Bolt	CAP 8x15	1
21	EGH1740-I21	Brake Belt		1
22	EGH1740-I22	Clip	E8	1
23	EGH1740-I23	Pin		1
24	EGH1740-I24	Motor	7.5HP	1
25	EGH1740-I25	Washer		1
26	EGH1740-I26	Hex. Head Bolt	12x25	1
27	TS-1503031	Hex. Socket Head Bolt	CAP 6x12	2
28	EGH1740-I28	Bracket		1
29	TS-2284302	Dome Cross Screw	M4x30L	2
30	EGH1740-I30	Limit Switch	Tm-1704	1
31	TS-1505051	Hex. Socket Head Bolt	CAP 10x35	4
32	EGH1740-I32	Shaft		1
33	EGH1740-I33	Support		1
34	EGH1740-I34	Plate		1
35	TS-1505061	Hex. Head Bolt	10x40	1
36	EGH1740-I36	Screw	16x170	1
37	TS-154010	Nut	M16	2
38	TS-1550071	Washer	M10	2
39	TS-2361101	Spring Washer	M10	6
40	TS-1505031	Hex. Head Bolt	10x25	2
44	EGH1740-I44	Electrical Box		1
45	EGH1740-I45	Limit Switch	Tm1307	1
46	EGH1740-I46	Cover		1
47	EGH1740-I47	Cover		1
48	EGH1740-I48	Block		1
49	EGH1740-I49	Motor Pulley		1
50	EGH1740-I50	Dome Cross Screw	M4x40L	2
51	TS-1540021	Nut	M4xP0.7	2

CABINET AND PANEL ASSEMBLY
 (FRONT MOVEABLE CHIP TRAY OPTIONS)

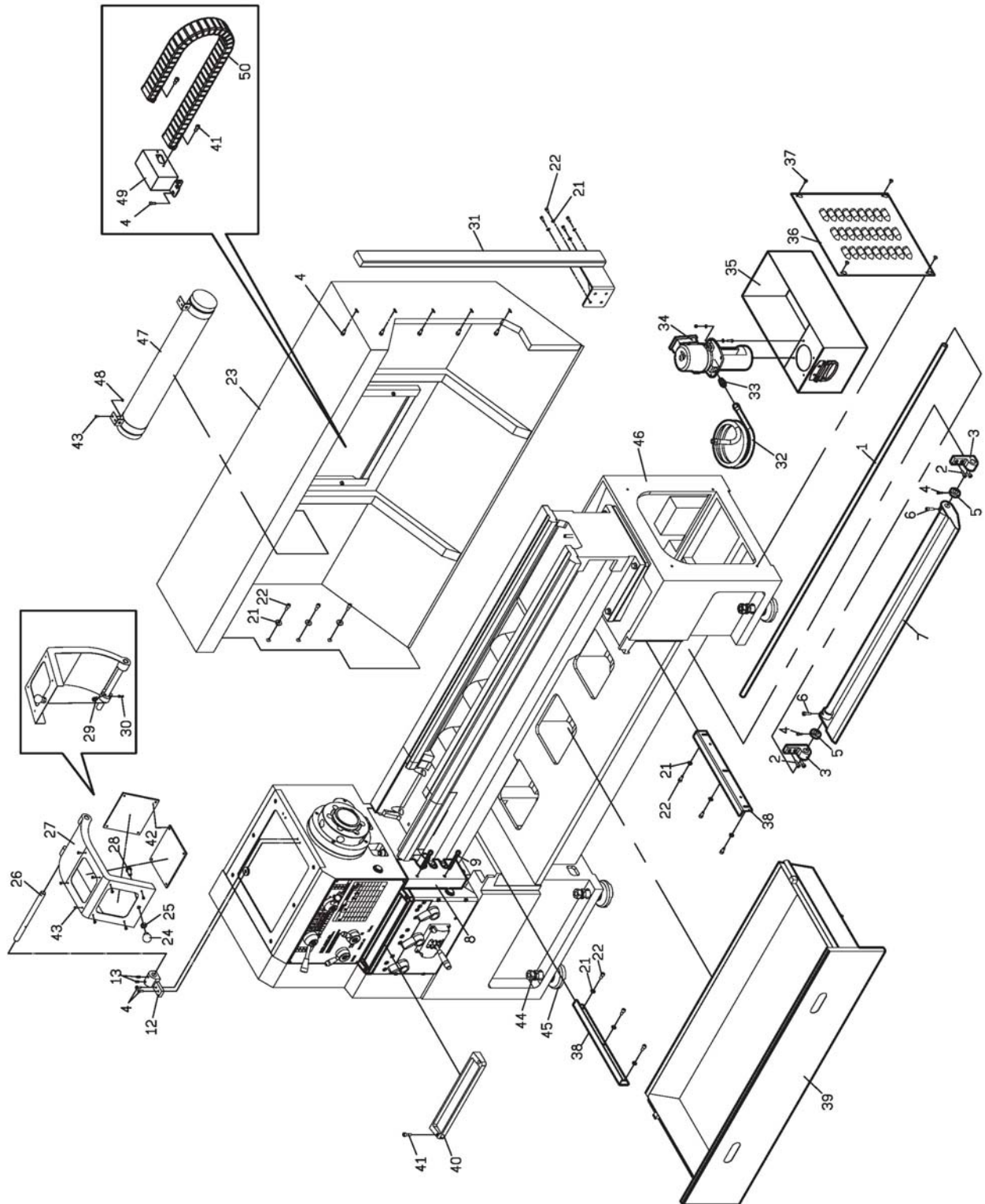

CABINET AND PANEL PARTS LIST
(FRONT MOVEABLE CHIP TRAY OPTIONAL)

Index No.	Parts No.	Description	Size	Qty.
1	EGH1740-J01	Shaft		1
	EGH1760-J01	Shaft		1
2	TS-1504051	Hex. Socket Head Bolt	CAP 8x25	4
3	EGH1740-J03	Pedal Bracket		2
4	TS-1503041	Hex. Socket Head Bolt	CAP6x16	15
5	EGH1740-J05	Ring		2
6	TS-1504051	Hex. Socket Head Bolt	CAP8x25	2
7	EGH1740-J07	Saddle	Model 1740	1
	EGH1760-J07	Saddle	Model 1760	1
8	EGH1740-J08	Plate		1
9	TS-1505071	Hex. Socket Head Bolt	CAP10x45	2
10	EGH1740-J10	Plate		1
12	EGH1740-J12	Small Bracket		1
13	TS-1524031	Set Screw	SET8x12	2
20	TS-2311081	Nut	M8	1
21	TS-1550061	Washer	M8	12
22	TS-1504041	Hex. Socket Head Bolt	CAP8x20	11
23	EGH1740-J23	Back Splash Guard	Model 1740	1
	EGH1760-J23	Back Splash Guard	Model 1760	1
24	EGH1740-J24	Knob		1
25	TS-2331121	Nut	M12xP1.75	1
26	EGH1740-J26	Pivot		1
27	EGH1740-J27	Chuck Safety Guard		1
28	TS-1506011	Hex. Socket Head Bolt	CAP12x20	1
29	TS-1503031	Hex. Socket Head Bolt	CAP6x12	1
30	TS-1522051	Set Screw	SET5x16	1
31	EGH1740-J31	Bracket		1
32	EGH1740-J32	Coolant Conduit 40	CT801x3/8"x72"	1
	EGH1760-J32	Coolant Conduit 60	CT801x3/8"x78"	1
33	EGH1740-J33	Nipple	3/8"PTx3/8"PH	1
34	EGH1740-J34	Coolant Pump	MC8150	1
35	EGH1740-J35	Coolant Tank		1
36	EGH1740-J36	Cover		1
37	TS-1534032	Dome Cross Screw	6x10	6
38	EGH1740-J38	Angle Steel		2
39	EGH1740-J39	Chip Tray		1
	EGH1760-J39	Chip Tray		1
40	EGH1740-J40	Cover		1
41	TS-1503051	Hex. Socket Head Bolt	CAP6x20	2
42	EGH1740-J42	Guard		2
43	TS-1514011	Dome Hex. Screw	M6x12	8
44	EGH1740-J44	Block		6
45	EGH1740-J45	Hexagon Head Bolt	M25x65	6
46	EGH1740-J46	Stand		1
	EGH1760-J46	Stand		1
47	EGH1740-J47	Work Lamp	Same as EGH1760	1



Index No.	Parts No.	Description	Size	Qty.
48	TS-1540041	Nut	M6	4
49	EGH1740-J49	Upper Socket Enclosure		1
50	EGH1740-J50	Cable Sheath (Alum.)	40-KR100No8-1270mm	1
	EGH1760-J50	Cable Sheath (Alum.)	60-KR100No8-1500mm	1

BED STOP ASSEMBLY (OPTIONAL) & PARTS LIST

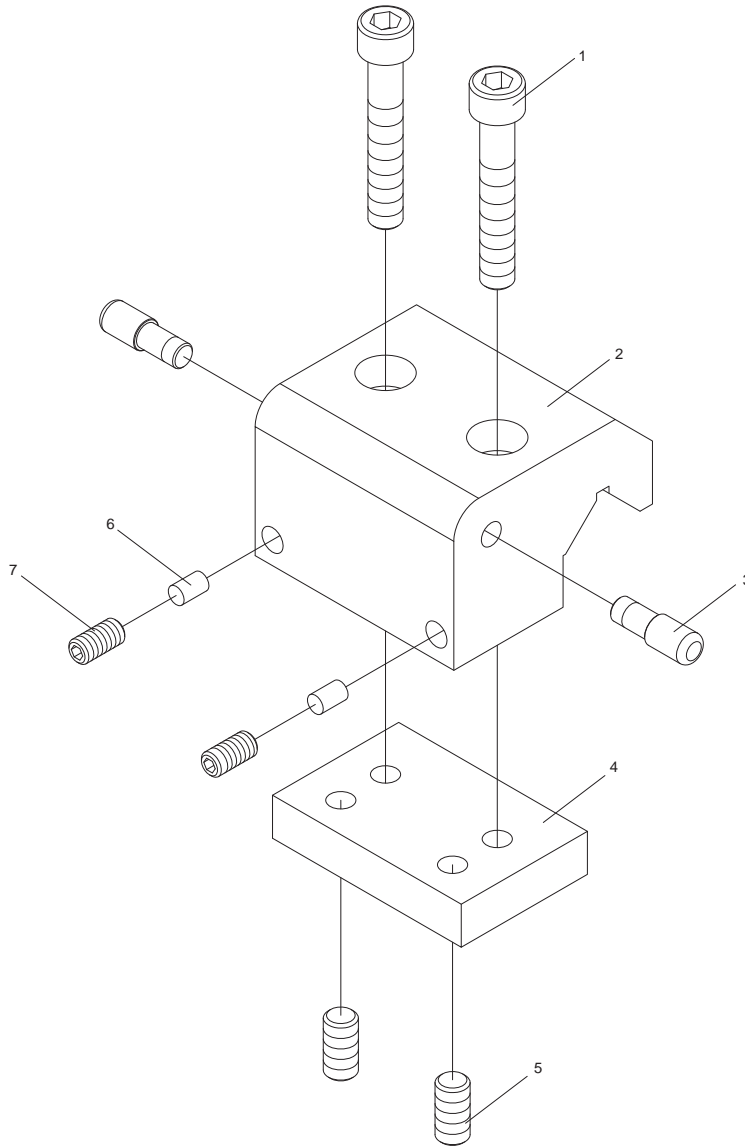

Index No.	Parts No.	Description	Size	Qty.
1	TS-1505101	Hex. Socket Head Bolt	M10x60	2
2	EGH1740-P02	Rivet	Ø2	2
3	EGH1740-P03	Name Plate		1
4	EGH1740-P04	Micro Dial		1
5	EGH1740-P05	Body		1
6	EGH1740-P06	Rod		1
7	EGH1740-P07	Clamp Plate		1
8	TS-1525041	Set Screw	M10x20	2
9	EGH1740-P09	Copper Pin		2
10	TS-1524041	Set Screw	M8x16	2
11	TS-1524031	Set Screw	M8x12	1
12	TS-1524031	Set Screw	M8x12	1

CONVENTIONAL TAILSTOCK ASSEMBLY PARTS LIST

Index No.	Parts No.	Description	Size	Qty.
1	EGH1740-K01	Screw & Nut	Assembly for replacement	1
2	EGH1740-K02	Key	6x6x25	1
3	BB-51105	Thrust Bearing	51105	2
4	EGH1740-K04	Flange		1
5	EGH1740-K05	Index Ring		1
6	EGH1740-K06	Handle		1
7	EGH1740-K07	Handle		1
8	EGH1740-K08	Bolt		1
9	EGH1740-K09	Fixed Screw		1
10	EGH1740-K10	Spring		3
11	EGH1740-K11	Steel Ball	1/4"	3
13	EGH1740-K13	Guide Key		1
14	EGH1740-K14	Oil Ball	1/4"	2
15	EGH1740-K15	Tail Stock		1
16	EGH1740-K16	Clamp Lever L & Cam Shaft L	Assembly for replacement	1
17	EGH1740-K17	Clamp Lever R & Cam Shaft R	Assembly for replacement	1
18	EGH1740-K18	Pins		1
19	EGH1740-K19	Quill		1
20	EGH1740-K20	Pin Nut		2
21	EGH1740-K21	Pivot Block		1
22	EGH1740-K22	Plate V		2
23	EGH1740-K23	Wiper V		2
24	EGH1740-K24	Plate F		2
25	EGH1740-K25	Wiper F		2
26	EGH1740-K26	Base		1
27	EGH1740-K27	Gib Screw		2
28	EGH1740-K28	Gib		1
29	EGH1740-K29	Hexagon Head & Screw		2
30	EGH1740-K30	Clamp Block		2
31	EGH1740-K31	Stud Bolt	M18x150L	1
32	EGH1740-K32	Warked Plate		1
33	EGH1740-K33	Stud Bolt	M18x180L	1
34	EGH1740-K34	Nut		1
35	EGH1740-K35	Washer		1
36	EGH1740-K36	Spring		1
37	EGH1740-K37	Washer		1
38	TS-1503051	Hexagon Socket Head Bolt	CAP 6x20	2
39	TS-1503031	Hexagon Socket Head Bolt	CAP 6x12	3
40	EGH1740-K103	Set Screw	SET 8x30	1
41	TS-1503021	Hexagon Socket Head Bolt	CAP 6x10	1
42	TS-1504111	Hexagon Socket Head Bolt	CAP 8x55	2
43	TS-1523071	Set Screw	SET 6x25	1
44	TS-2360181	Washer	M18	4
45	TS-2311181	Nut	M18	3
46	TS-2285121	Dome Cross Screw	M5x12	8
47	TS-2361181	Spring Washer	M18	2
48	EGH1740-K111	Pin	Ø4x38	1
49	EGH1740-K112	Oil Seal	DH-60	1
50	TS-1540041	Nut	M6	1

STEADY REST ASSEMBLY

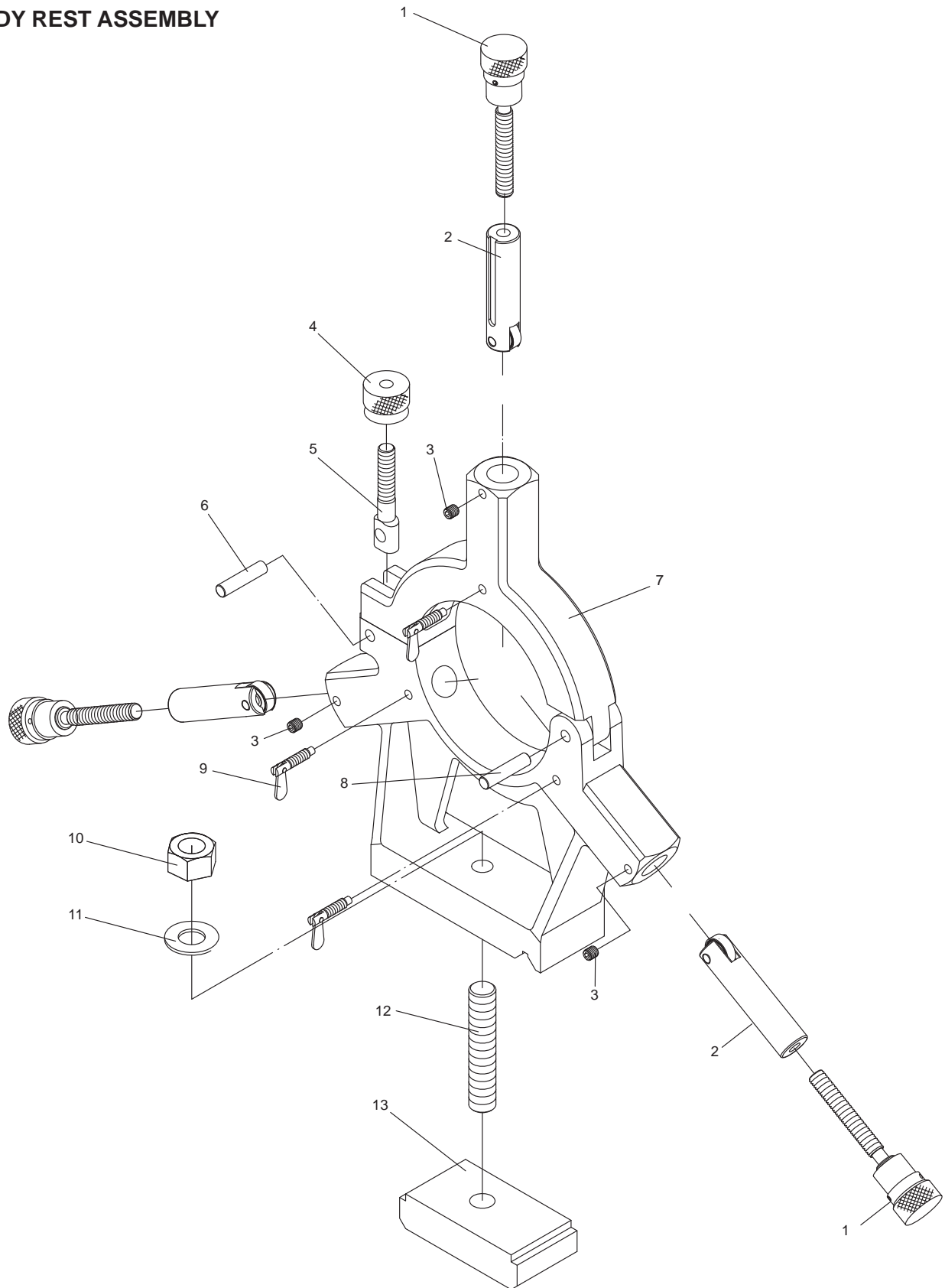

STEADY REST ASSEMBLY PARTS LIST

Index No.	Parts No.	Description	Size	Qty.
1	EGH1740-Q01	Adjusting knob , Spring pin(Ø4x40L) , Collar, Screw	Assembly for Replacement	3
2	EGH1740-Q02	Finger , Pin , Ball bearing(627)	Assembly for Replacement	3
3	TS-1524011	Set Screw	M8x8L	3
4	EGH1740-Q04	Knob Nut		1
5	EGH1740-Q05	Clamp Screw		1
6	EGH1740-Q06	Pin		1
7	EGH1740-Q07	Top Casting & Base Casting	Assembly for replacement	1
8	EGH1740-Q08	Hinge Pin		1
9	EGH1740-Q09	Single Wing Bolt		3
10	TS-2331121	Nut	M12xP1.75	1
11	EGH1740-Q11	Spring Washer	M12	1
12	EGH1740-Q12	Hexagon Head Bolt	M12xP1.75x75L	1
13	EGH1740-Q13	Clamp Plate		1
	EGH17-SRA	Steady Rest Assembly		1

FOLLOW REST ASSEMBLY

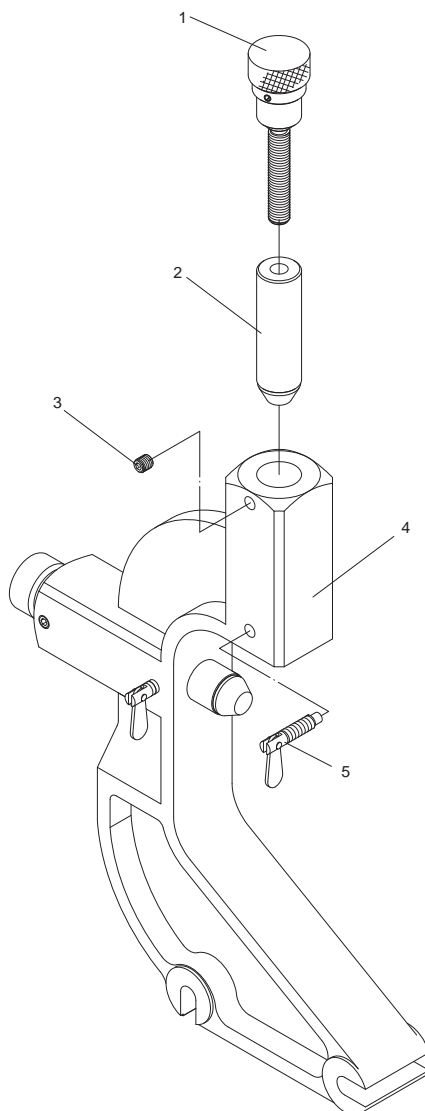

FOLLOW REST ASSEMBLY PARTS LIST

Index No.	Parts No.	Description	Size	Qty.
1	EGH1740-R01	Adjusting Screw, Spring Pin 4x40L, Collar, Screw	Assembly for replacement	2
2	EGH1740-R02	Finger, Bracket	Assembly for replacement	2
2-1	EGH1740- R02BB	Finger, Ball Bearing(627), Pin	Assembly for replacement	2
3	TS-1524011	Set Screw	M8x8L	2
4	EGH1740-R04	Casting		1
5	EGH1740-R05	Single Wing Bolt		1
	EGH17-FCA	Follow Rest Assembly w/ Copper (Key No.2)		1
	EGH17-FBBA	Follow Rest Assembly w/ Ball Bearing (Key No.2-1)		1

EGH1740/EGH1760 ELECTRICAL BOX ASSEMBLY & PARTS LIST

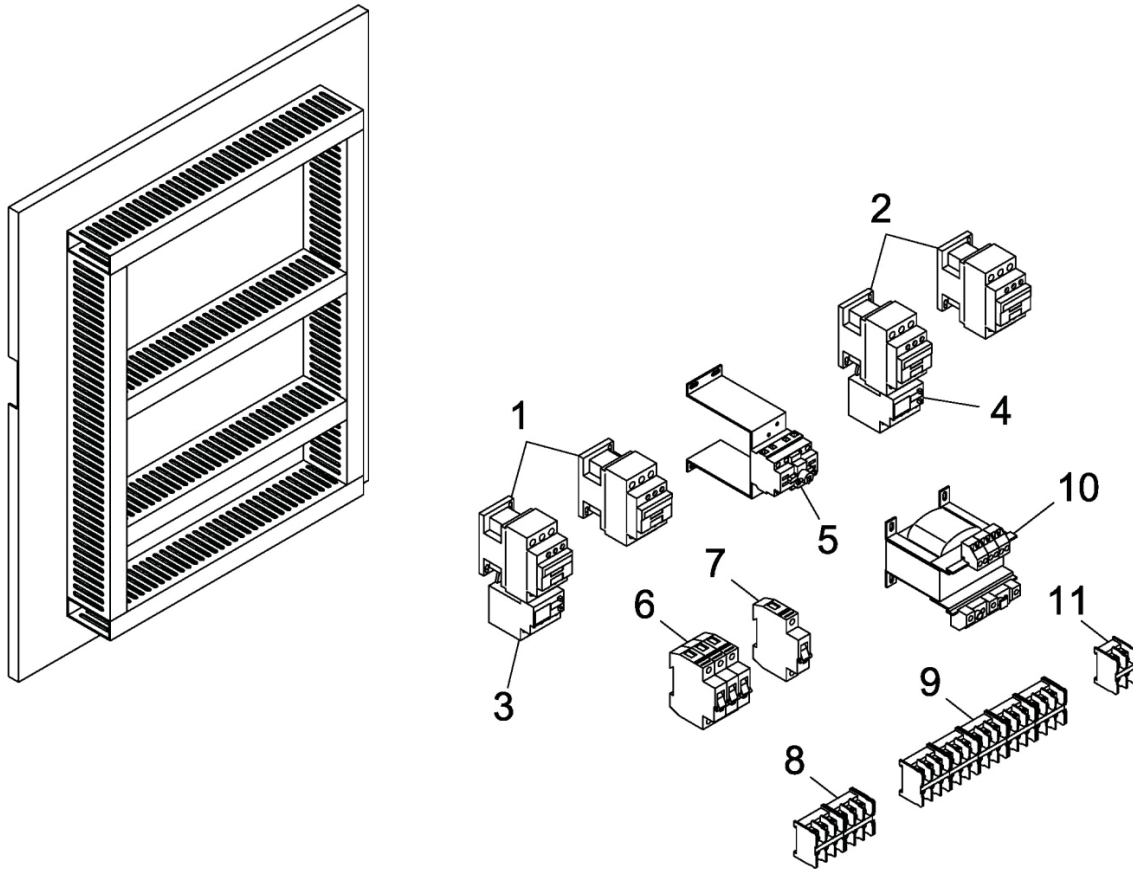

Index No.	Parts No.	Description	Size	Qty.
1	EGH1740-EL01	Magnetic Switch	AC24V	2
2	EGH1740-EL02	Magnetic Switch	AC24V	2
3	EGH1740-EL03	Over Relay	23A-32A	1
4	EGH1740-EL04	Over Relay	0.25A-0.4A	1
5	EGH1740-EL05	Cam Switch	32A	1
6	EGH1740-EL06	Fuse Base		1
	EGH1740-FU25A	Fuse (not shown) same as EGH1760	25A	3
7	EGH1740-EL07	Fuse Base		1
	EGH1740-FU6A	Fuse (not shown) same as EGH1760	6A	1
8	EGH1740-EL08	Terminal Board	30A	2
9	EGH1740-EL09	Terminal Board	20A	5
10	EGH1740-EL10	Transformer	140VA	1
	EGH1740-FU4A	Fuse (not shown) same as EGH1760	24V, 4A	1
	EGH1740-FU1A	Fuse (not shown) same as EGH1760	110V, 1A	1
11	EGH1740-EL11	Terminal Board	2P 20A	1

892156 5C COLLET CLOSER (OPTIONAL)

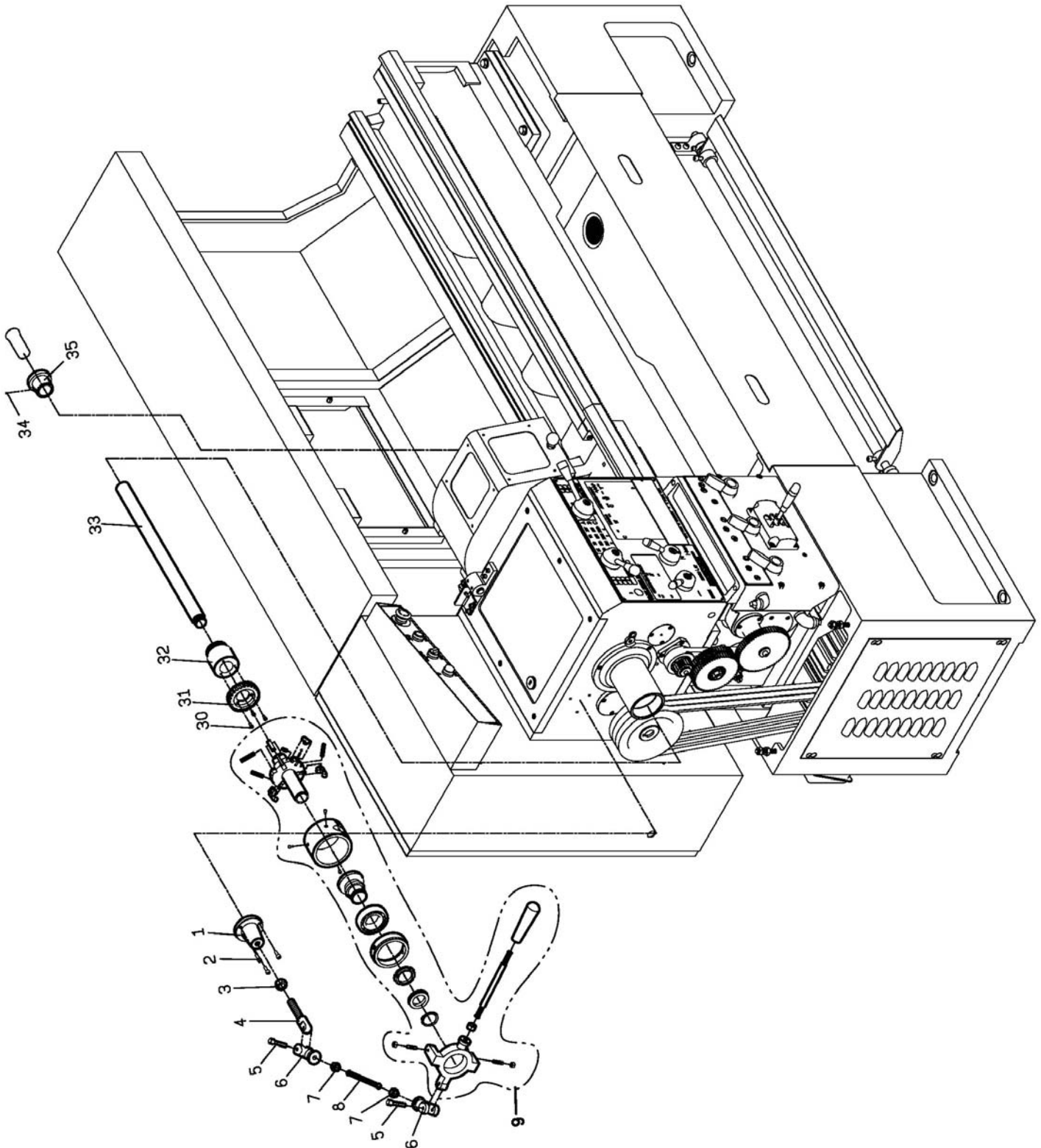

892156 5C COLLET CLOSER (OPTIONAL) PARTS LIST

Index No.	Parts No.	Description	Size	Qty.
1	EGH1740-O02	Bracket		1
2	TS-1503061	Hex. Socket Head Bolt	M6x25	3
3	TS-154010	Nut	M16	1
4	EGH1740-O04	Bolt		1
5	EGH1740-O05	Bolt		1
6	EGH1740-O06	Connector Casting		1
7	TS-0561051	Nut	W½"	2
8	EGH1740-O08	Screw	W½ x 155mm	1
9	EGH1740-O09	Handle Casting		1
		Set Screw	M8x10	2
		Nut	M8	2
		Nut	½" - 12UNC	1
		Handle Rod		1
		Handle		1
		Clip	S34	1
		Washer	Ø52.4xØ34.4x9	1
		Nut		1
		Bearing And Retainer		1
		Ball Bearing	6208	1
		Cam		1
		Hex. Socket Head Bolt	M4x8	3
		Collar		1
		Tube		1
		Finger		3
		Pivot Pin	Ø6x40	3
		Knob		1
Steel Ball	Ø5	1		
Spring		1		
Pin	Ø5x18	1		
30	TS-1502031	Hex. Socket Head Bolt	M5x12	3
31	EGH1740-O31	Index Ring		1
32	EGH1740-O32	Hub		1
33	EGH1740-O33	Tube		1
34	EGH1740-O34	Pin		1
35	EGH1740-O35	Bushing		1
	892156	5C Collet Closer Assembly		1

EGH1740/EGH1760 CONTROL BOX ASSEMBLY & PARTS LIST

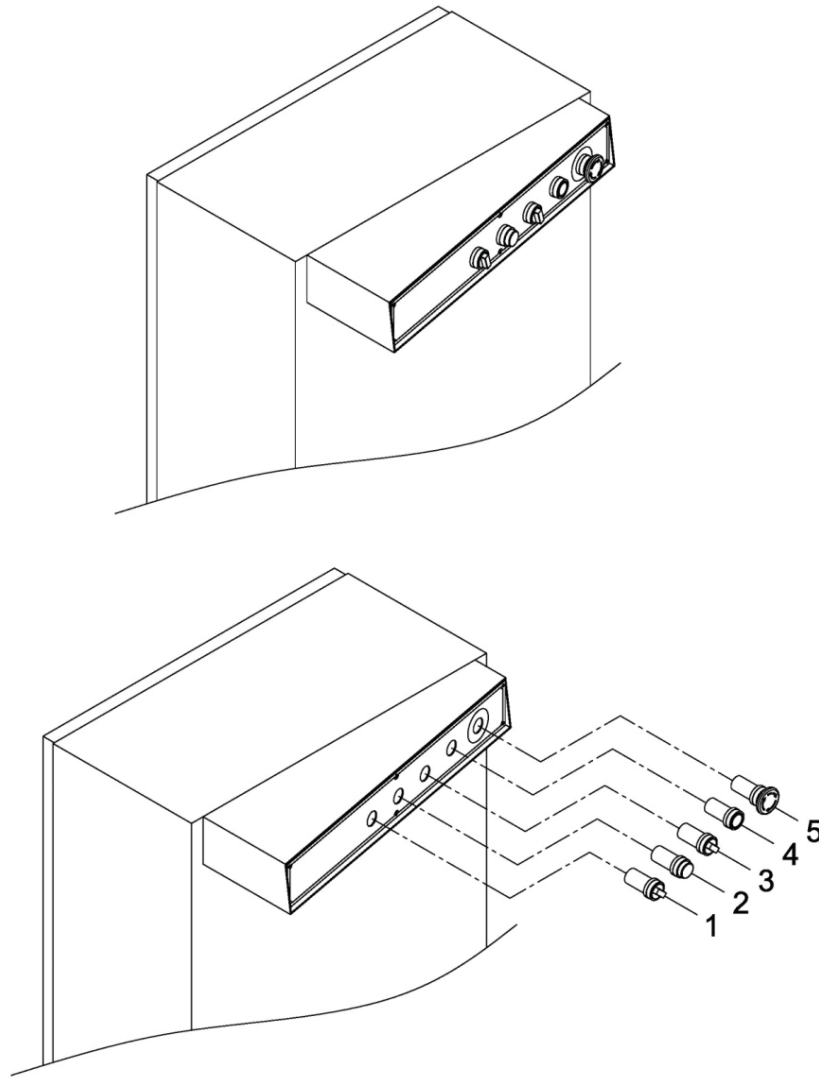

Index No.	Parts No.	Description	Size	Qty.
1	EGH1740-CB01	Light Switch	SW2	1
2	EGH1740-CB02	Power Lamp	W1	1
3	EGH1740-CB03	Pump Switch	SW1	1
4	EGH1740-CB04	Jog Switch	PB1	1
5	EGH1740-CB05	Emergency Stop Switch	E-STOP	1