

Tanaka



Parts Catalog



Chain Saw

Model: ECS-415

FIG. 1 ENGINE

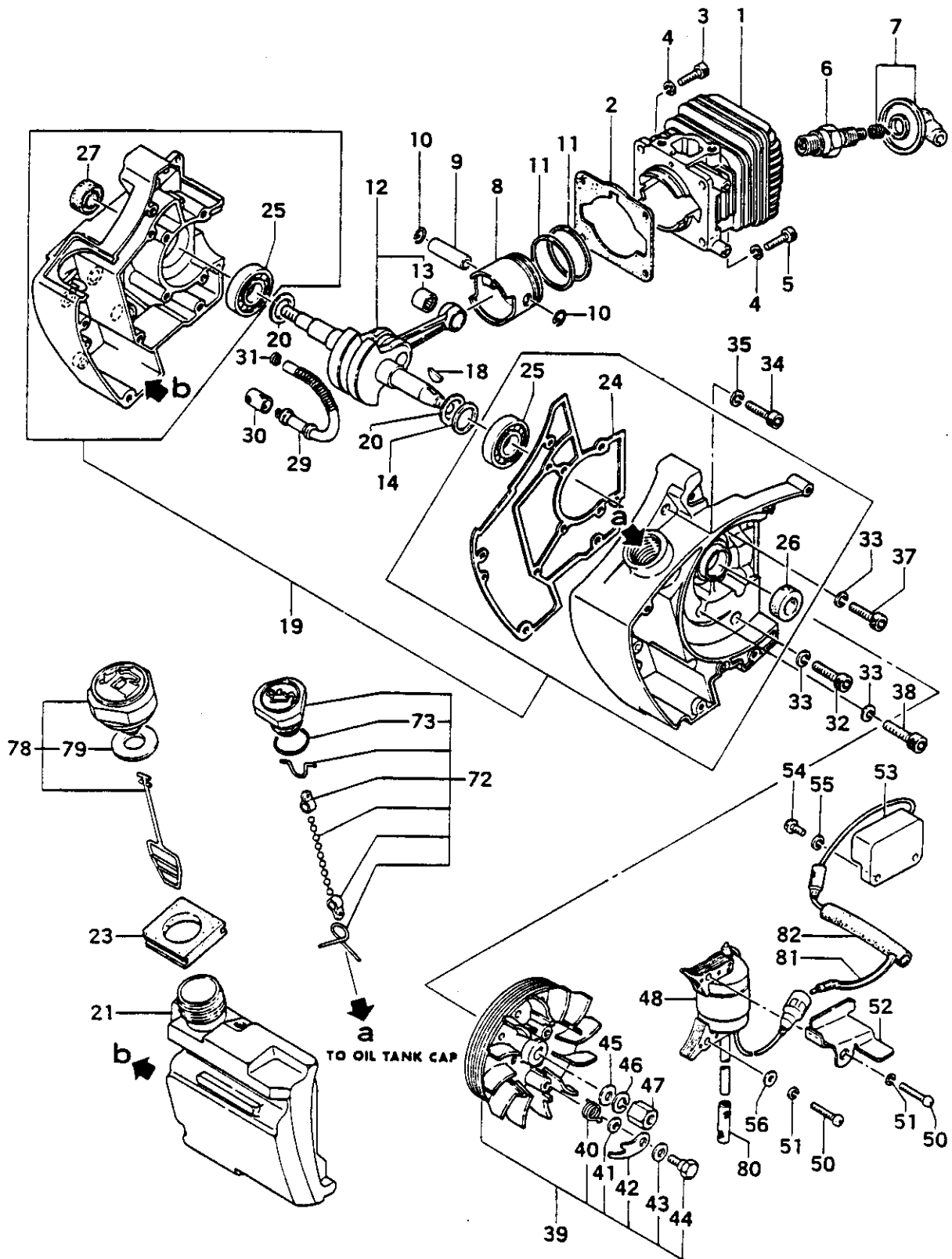

REFERENCE NUMBER	PRODUCTION PART NUMBER	PART NAME	QUANTITY	SERIAL NUMBER	SPARE PART NUMBER
FIG.1 ENGINE					
1-001	002-04050-200	CYLINDER	1		002 1220 3
1-002	017-04050-200	CYLINDER GASKET	1		017 0490 7
1-003	990-51050-153	HEX. HOLE BOLT 5X15	2	-0158096	990 5006 5
1-003	990-51050-203	HEX. HOLE BOLT 5X20	2	0158097-	990 5009 2
1-004	992-10050-012	S.WASHER 5	4		992 1012 4
1-005	990-51050-203	HEX. HOLE BOLT 5X20	2	-0158096	990 5009 2
1-005	990-51050-253	HEX. HOLE BOLT 5X25	2	0158097-	990 5014 4
1-006	018-11610-200	SPARK PLUG BPM-7A	1		018 0260 7
1-007	157-01800-901	SPARK PLUG CAP ASS'Y	1		157 0020 9
1-008	031-04050-200	PISTON	1		031 0630 5
1-009	037-01400-200	PISTON PIN	1		037 0030 9
1-010	039-00000-201	PISTON PIN CIRCLIP	2		039 0000 2
1-011	041-04050-200	PISTON RING ED	2		041 0300 8
1-012	046-04050-800	CRANK SHAFT COMP.	1	-C194052	046 1040 1
1-012	046-04050-810	CRANK SHAFT COMP.	1	-C231285	046 1041 0
1-012	046-04060-801	CRANK SHAFT COMP.	1	C231286-	046 1080 9
1-013	999-62091-325	NEEDLE BEARING F-910	1		999 6207 2
1-014	071-02007-200	CRANK SHAFT SHIM 0.05	V		071 0040 6
1-014	071-02007-210	CRANK SHAFT SHIM 0.10	V		071 0041 5
1-014	071-02007-220	CRANK SHAFT SHIM 0.15	V		071 0042 4
1-014	071-02007-230	CRANK SHAFT SHIM 0.20	V		071 0043 3
1-018	068-10100-200	WOOD-RUFF KEY 3X13X4.5	1		068 0060 6
1-019	072-04050-910	CRANK CASE ASS'Y	1	-0158895	072 0511 6
1-019	072-04050-920	CRANK CASE ASS'Y	1	0158896-	072 0512 5
1-020	070-02401-201	CRANK SHAFT WASHER 15X22	2	C231286-	070 0020 5
1-021	591-04050-200	FUEL TANK	1		591 1570 2
1-023	601-04050-200	TANK HOLDING RUBBER	1		601 0140 4
1-024	090-04050-201	CRANK CASE GASKET	1		090 0690 8
1-025	999-61620-200	BALL BEARING #6202	2		999 6139 8
1-026	999-66122-200	OIL SEAL TB12227	1		999 6609 2
1-027	999-66152-500	OIL SEAL 15257	1		999 6622 3
1-029	505-32350-203	OIL PIPE B	1		505 0062 0
1-030	510-32350-200	FILTER NET	1		510 0120 5
1-031	680-00803-202	CLIP	1		680 0091 2
1-032	990-51050-253	HEX. HOLE BOLT 5X25	5		990 5014 4
1-033	992-10050-012	S.WASHER 5	9		992 1012 4
1-034	990-51050-203	HEX. HOLE BOLT 5X20	1		990 5009 2
1-035	992-10050-012	S.WASHER 5	1		992 1012 4
1-037	990-51050-353	HEX. HOLE BOLT 5X35	1		990 5017 1
1-038	990-51050-303	HEX. HOLE BOLT 5X30	3	C231286-	990 5016 2
1-039	155-21704-911	MAGNETO ROTOR ASS'Y	1		155 0781 7
1-040	790-01800-200	STARTER PAWL SPRING	2		790 0040 2
1-041	786-00601-200	STARTER PAWL WASHER	2		786 0000 3
1-042	788-00601-203	STARTER PAWL	2		788 0010 4
1-043	822-00601-200	STARTER PAWL SHIM 0.6T	2		822 0000 8
1-044	793-10200-201	STEP BOLT	2		793 0030 6
1-045	065-00000-200	FLYWHEEL WASHER	1		065 0000 3
1-046	992-10070-012	S.WASHER 7	1		992 1024 9
1-047	066-01800-200	FLYWHEEL NUT	1		066 0050 5
1-048	167-20763-800	IGNITION COIL COMP.	1		167 0770 8
1-050	990-11040-181	SCREW 4X18	2		990 1042 1
1-051	992-10040-012	S.WASHER 4	2		992 1007 2
1-052	198-01800-230	CURD CLAMP	1		198 0165 4
1-053	159-21401-871	IGNITOR TTI-1E	1		159 0372 5

REFERENCE NUMBER	PRODUCTION PART NUMBER	PART NAME	QUANTITY	SERIAL NUMBER	SPARE PART NUMBER
FIG.1 ENGINE					
1-054	770-11040-161	SCREW 4X16	2		
1-055	772-10040-012	S.WASHER 4	2		
1-056	772-00040-011	SMALL WASHER 4	1		
1-072	624-32550-901	OIL TANK CAP ASS'Y	1		
1-078	635-32550-900	TANK CAP ASS'Y	1		
1-080	755-32050-200	CORD INSULATOR TUBE	1		
1-081	173-04050-800	PRIMARY CORD COMP.	1		
1-082	203-01800-200	CORD GROMMET	1		
1-073	999-67022-000	U-RING P22	1		
1-079	642-04050-200	TANK CAP GASKET	1		
				990 1040	3
				992 1007	2
				992 0008	2
				624 0090	3
				635 0120	7
				755 0000	7
				173 0430	6
				203 0040	1
				999 6723	5
				642 0080	8

FIG.2 CLUTCH & BRAKE

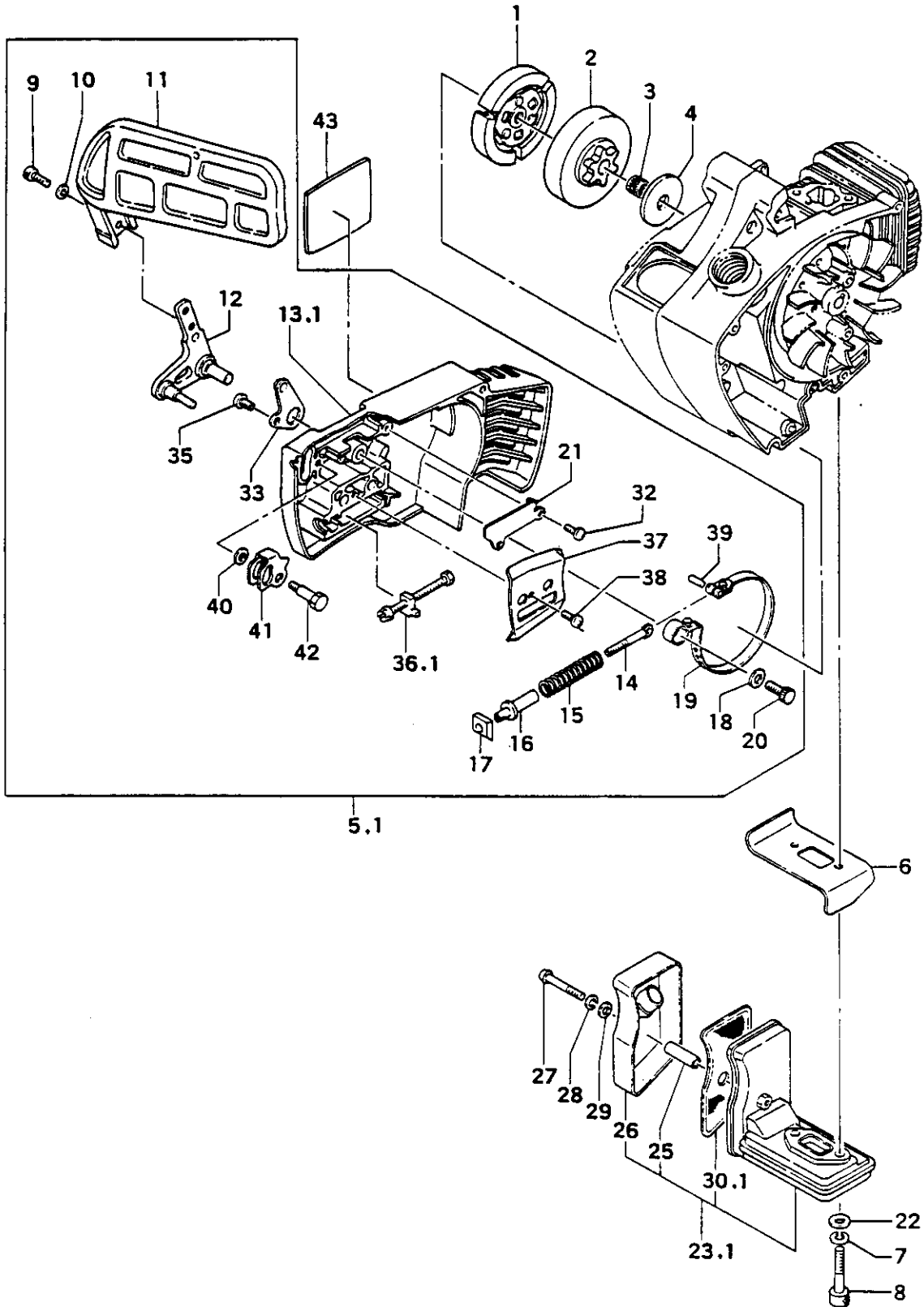

REFERENCE NUMBER	PRODUCTION NUMBER	PART NAME	QUANTITY	SERIAL NUMBER	SPARE PART NUMBER
FIG.2 CLUTCH & BRAKE					
2-001	297-01801-800	CLUTCH COMP.	1		287 0010 2
2-002	310-01857-810	CLUTCH HOUSING COMP. 0.325 ±	1		310 0301 4
2-003	999-62101-301	NEEDLE BEARING 101310	1		999 6210 6
2-004	358-04050-200	CLUTCH WASHER	1		358 0080 0
2-005.1	040-32550-900	SIDE CASE ASS'Y	1		040 0670 9
2-006	737-04050-200	MUFFLER GASKET	1		737 0370 3
2-007	992-10060-012	S.WASHER 6	2		992 1019 7
2-008	990-51060-353	HEX. HOLE BOLT 6X35	2		990 5025 0
2-009	990-51050-103	HEX. HOLE BOLT 5X10	2		990 5003 8
2-010	992-10050-012	S.WASHER 5	2		992 1012 4
2-011	390-32600-803	BRAKE HAHOLE COMP.	1		380 0070 6
2-012	361-32550-802	BRAKE LEVER COMP.	1		361 0130 2
2-013.1	040-32550-201	SIDE CASE	1		040 0460 6
2-014	372-32550-200	BRAKE ROD	1		372 0160 3
2-015	374-32550-200	BRAKE SPRING	1		374 0250 3
2-016	397-32550-200	BRAKE ADJUST BOLT	1		387 0050 1
2-017	377-32550-201	BRAKE LOCK PLATE	1		377 0110 3
2-018	368-32057-200	BRAKE SHAFT WASHER	1		368 0120 4
2-019	374-32550-801	BRAKE BAND COMP.	1		378 0120 7
2-020	990-51050-103	HEX. HOLE BOLT 5X10	1		990 5003 8
2-021	389-32550-201	BRAKE SPRING HOLDER	1		389 0070 9
2-022	992-01060-011	WASHER 6	2		992 0040 8
2-023.1	705-04052-900	MUFFLER ASS'Y	1		705 0970 8
2-025	740-01802-200	MUFFLER COLLAR	1		740 0080 5
2-026	717-01800-820	MUFFLER BODY B COMP.	1		717 0331 8
2-027	990-11050-351	SCREW 5X35	1		990 1090 8
2-028	992-10050-012	S.WASHER 5	1		992 1012 4
2-029	992-01050-011	WASHER 5	1		992 0035 6
2-030.1	732-01802-201	SPARK ARRESTER	1		732 0070 9
2-032	990-11040-081	SCREW 4X8	2		990 1026 3
2-033	359-32550-210	CENTER SPRING	1		359 0051 5
2-035	990-11040-081	SCREW 4X8	1		990 1026 3
2-036.1	116-32550-900	CHAIN TENSION BOLT ASS'Y	1		116 0200 2
2-037	462-32550-200	GUIDE PLATE B	1		462 0190 2
2-038	990-11040-061	SCREW 4X6	1		990 1025 4
2-039	993-24040-120	SPRING PIN 4X12	1		993 2015 7
2-040	992-00050-011	SMALL WASHER 5	1		992 0009 1
2-041	373-32550-200	BRAKE ARM	1		373 0170 7
2-042	382-32550-200	STEP BOLT A	1		382 0060 3
2-043	906-32551-201	NAME PLATE	1		906 2270 4

FIG.3 CARBURETOR & CLEANER

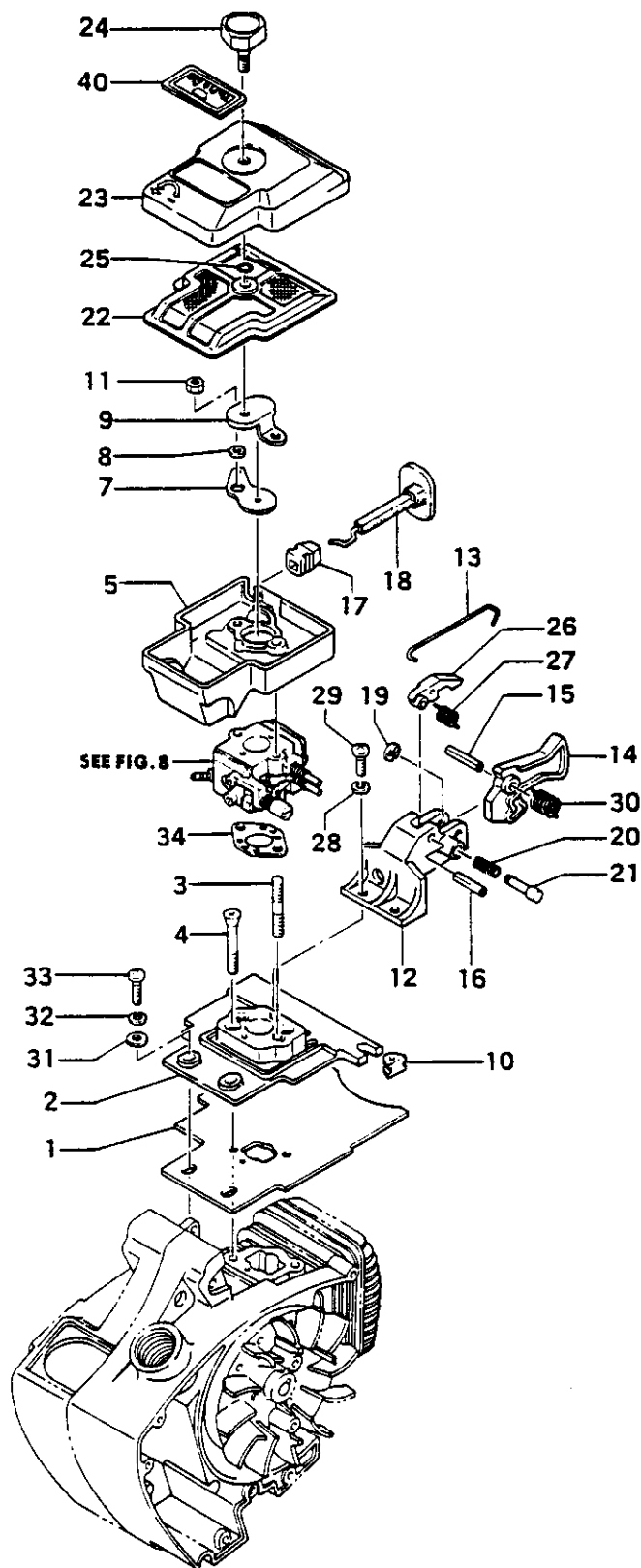

REFERENCE NUMBER	PRODUCTION PART NUMBER	PART NAME	QUANTITY	SERIAL NUMBER	SPARE PART NUMBER
FIG.3 CARBURETOR & CLEANER					
3-001	133-04050-201	HEAT SHIELD	1		133 0321 3
3-002	404-04050-800	CARBURETOR INSULATOR COMP.	1	-0158895	404 0390 4
3-002	404-04050-801	CARBURETOR INSULATOR COMP.	1	0158896-	404 0391 3
3-003	100-11600-210	STUD BOLT 5X53	2		100 0211 3
3-004	990-12050-251	F.H.SCREW 5X25	2	-0158895	990 1183 1
3-004	990-12050-281	F.H.SCREW 5X28	2	0158896-	990 1216 2
3-005	423-04050-201	CLEANER BODY	1		423 0560 8
3-007	700-32550-210	CHOKE VALVE	1		700 2780 2
3-008	708-32350-200	CHOKE VALVE SHIM	1		708 0150 1
3-009	476-04050-200	BLOW OVER CHECK BOARD	1		476 0200 3
3-010	203-06000-200	PRIMARY CORD GROMMET	1		203 0090 6
3-011	991-74050-010	U NUT 5	2		991 7009 7
3-012	256-32550-201	THROTTLE HOLDER	1		256 0090 2
2-013	490-32550-210	THROTTLE ROD	1		490 0191 6
3-014	060-32550-202	THROTTLE LEVER	1		060 0450 5
3-015	993-24050-200	SPRING PIN 5X20	1		993 2022 7
3-016	993-24040-200	SPRING PIN 4X20	1		993 2021 8
3-017	707-32550-201	CHOKE ROD HOLDING RUBBER	1		707 0060 9
3-018	704-32550-810	CHOKE BUTTON COMP.	1		704 0061 6
3-019	993-55030-002	STOP RING 3	1		993 5025 1
3-020	066-32300-201	STOPPER SPRING	1		066 0420 6
3-021	064-32300-201	PUSH PIN	1		064 0050 1
3-022	420-04050-800	CLEANER ELEMENT COMP.	1		420 0190 6
3-023	051-32550-201	CLEANER COVER	1		051 0220 2
3-024	156-32550-800	CLEANER CAP KNOB COMP.	1		156 0240 2
3-025	999-67003-000	O-RING P3	1		999 6701 3
3-026	259-32350-202	THROTTLE LOCK LEVER	1		259 0100 3
3-027	261-32350-201	THROTTLE LOCK SPRING	1		261 0101 9
3-028	992-10050-012	S.WASHER 5	2		992 1012 4
3-029	990-11050-141	SCREW 5X14	2		990 1068 9
3-030	061-32350-203	THROTTLE LEVER SPRING	1		061 0390 0
3-031	992-00050-011	SMALL WASHER 5	2		992 0009 1
3-032	992-10050-012	S.WASHER 5	2		992 1012 4
3-033	990-11050-181	SCREW 5X18	2		990 1073 1
3-034	402-04019-211	CARBURETOR GASKET	1		402 0051 2
3-040	912-32550-200	CLEANER COVER MARK	1		912 0270 1

FIG.4 RECOIL STARTER

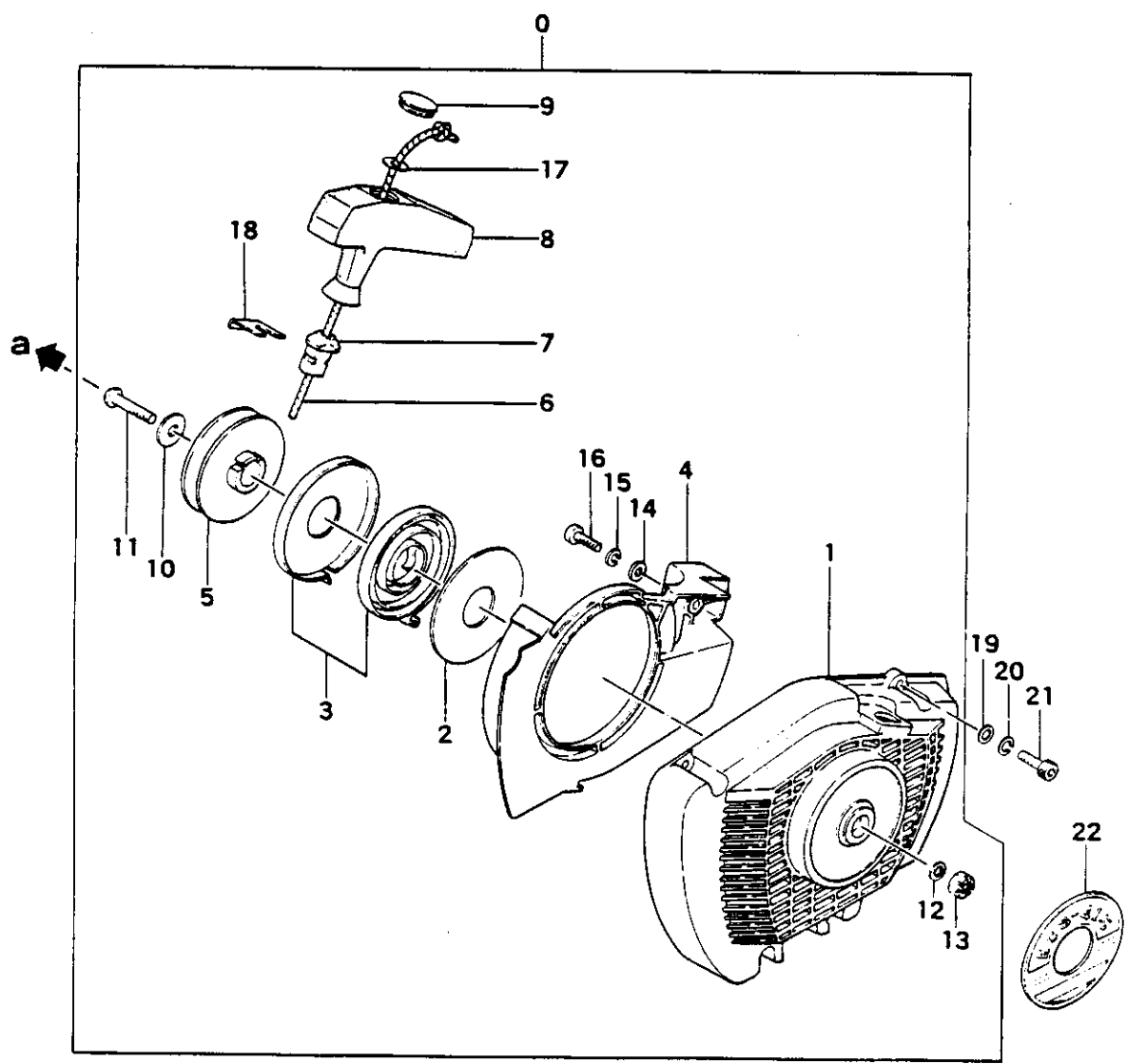
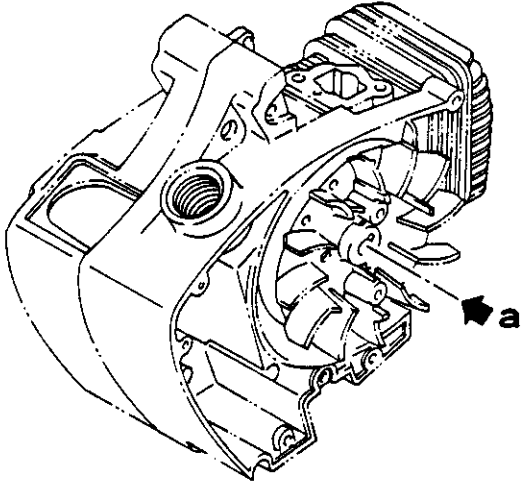

REFERENCE NUMBER	PRODUCTION PART NUMBER	PART NAME	QUANTITY	SERIAL NUMBER	SPARE PART NUMBER
FIG.4 RECOIL STARTER					
4-000	756-04050-901	RECOIL STARTER ASS'Y	1		756 0780 7
4-001	112-04050-800	FAN CASE COMP.	1		112 1610 2
4-002	827-04060-210	RECOIL SPRING CASE COVER	1		827 0071 1
4-003	778-00601-900	RECOIL SPRING CASE ASS'Y	1		778 0120 1
4-004	145-01850-202	COVER	1		145 0000 8
4-005	774-00601-806	STARTER ROPE REEL COMP.	1		774 0031 6
4-006	793-01800-200	STARTER ROPE 3.5X960	1		783 0070 1
4-007	780-11600-201	ROPE GUIDE	1		780 0120 8
4-008	795-11600-202	STARTER HANDLE	1		785 0140 7
4-009	833-10207-200	STARTER HANDLE CAP	1		833 0000 8
4-010	992-08050-006	SPECIAL WASHER 5	1		992 0068 4
4-011	994-31050-251	S.SCREW 5X25	1	-0140301	994 3015 3
4-011	990-11050-251	SCREW 5X25	1	0140302-	990 1082 9
4-012	992-20050-006	TOOTHED LOCK WASHER 5	1		992 2004 4
4-013	991-20050-011	HEX.SLOTTED NUT	1		991 2001 0
4-014	992-00050-011	SMALL WASHER 5	1		992 0009 1
4-015	992-10050-012	S.WASHER 5	1		992 1012 4
4-016	990-11050-141	SCREW 5X14	1		990 1068 9
4-017	795-11600-200	ROPE STOPPER	1		795 0050 4
4-018	781-11600-200	HANDLE GUIDE HOLDER METAL	1		781 0000 8
4-019	992-00050-011	SMALL WASHER 5	4		992 0009 1
4-020	992-10050-012	S.WASHER 5	4		992 1012 4
4-021	990-51050-153	HEX. HOLE BOLT 5X15	4		990 5006 5
4-022	915-32551-200	STARTER MARK	1		915 0360 8

FIG.5 REAR HANDLE

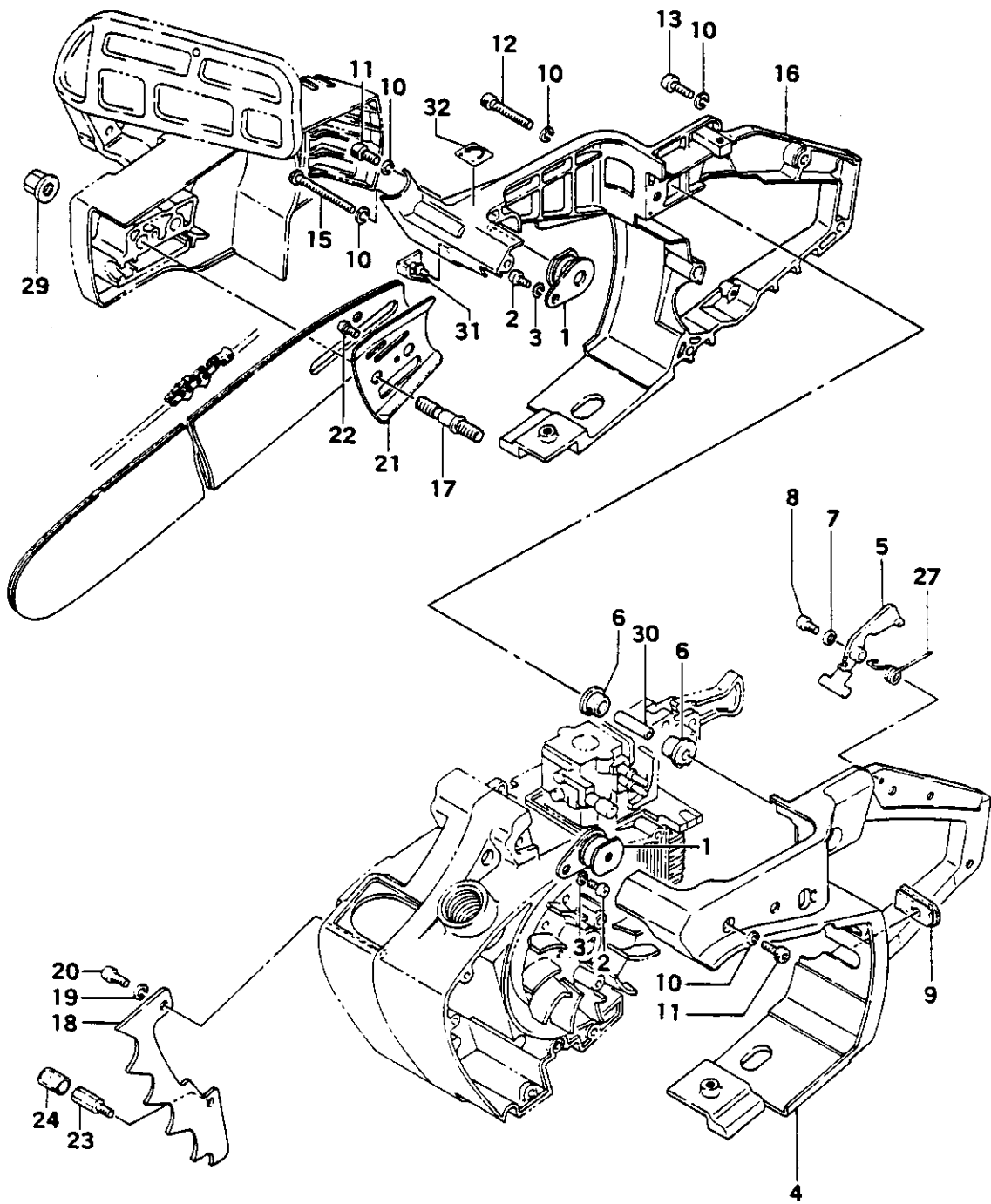

REFERENCE NUMBER	PRODUCTION PART NUMBER	PART NAME	QUANTITY	SERIAL NUMBER	SPARE PART NUMBER
FIG.5 RAER HANDLE					
5-001	222-32350-801	SIDE DAMPER COMP.	2		222 0050 7
5-002	990-11050-121	SCREW 5X12	2		990 1065 2
5-003	992-10050-012	S.WASHER 5	2		992 1012 4
5-004	010-32551-202	HANDLE/REAR A	1		010 0590 1
5-005	257-32050-202	SAFETY LEVER	1		257 0020 0
5-006	250-32550-200	SAFETY DAMPER	2		250 0070 6
5-007	992-01030-011	WASHER 3	1		992 0028 6
5-008	990-11030-081	SCREW 3X8	1		990 1014 8
5-009	202-01800-201	SECONDARY CORD GROMMET	1		202 0051 0
5-010	992-10050-012	S.WASHER 5	5		992 1012 4
5-011	990-51050-153	HEX. HOLE BOLT 5X15	2		990 5006 5
5-012	990-51050-353	HEX. HOLE BOLT 5X35	1		990 5017 1
5-013	990-11050-161	SCREW 5X16	1		990 1070 4
5-015	990-11050-451	SCREW 5X45	1		990 1098 0
5-016	011-32550-213	HANDLE/REAR B	1		011 0220 0
5-017	101-32530-200	CHAIN BAR STUD BOLT	2		101 0130 2
5-018	460-32350-210	SPIKE	1		460 0132 4
5-019	992-10050-012	S.WASHER 5	1		992 1012 4
5-020	990-11050-121	SCREW 5X12	1		990 1065 2
5-021	461-32550-200	GUIDE PLATE A	1		461 0240 3
5-022	990-11040-061	SCREW 4X6	1		990 1025 4
5-023	125-32060-210	CHAIN CATCHER	1		125 0022 4
5-024	700-01012-018	VINYL PIPE	1		700 0270 2
5-027	258-32050-200	SAFETY SPRING	1		258 0090 6
5-027	121-32530-200	CHAIN BAR CLAMP NUT	2		121 0140 5
5-030	251-32350-200	SAFETY DAMPER COLLER	1		251 0210 7
5-031	240-32550-200	SHEET DUMPER	1	C193853-	240 0070 3
5-032	922-32550-200	OIL ADJUSTING MARK	1	C193853-	922 0010 6

FIG.6 HANDLE & STOP SWITCH

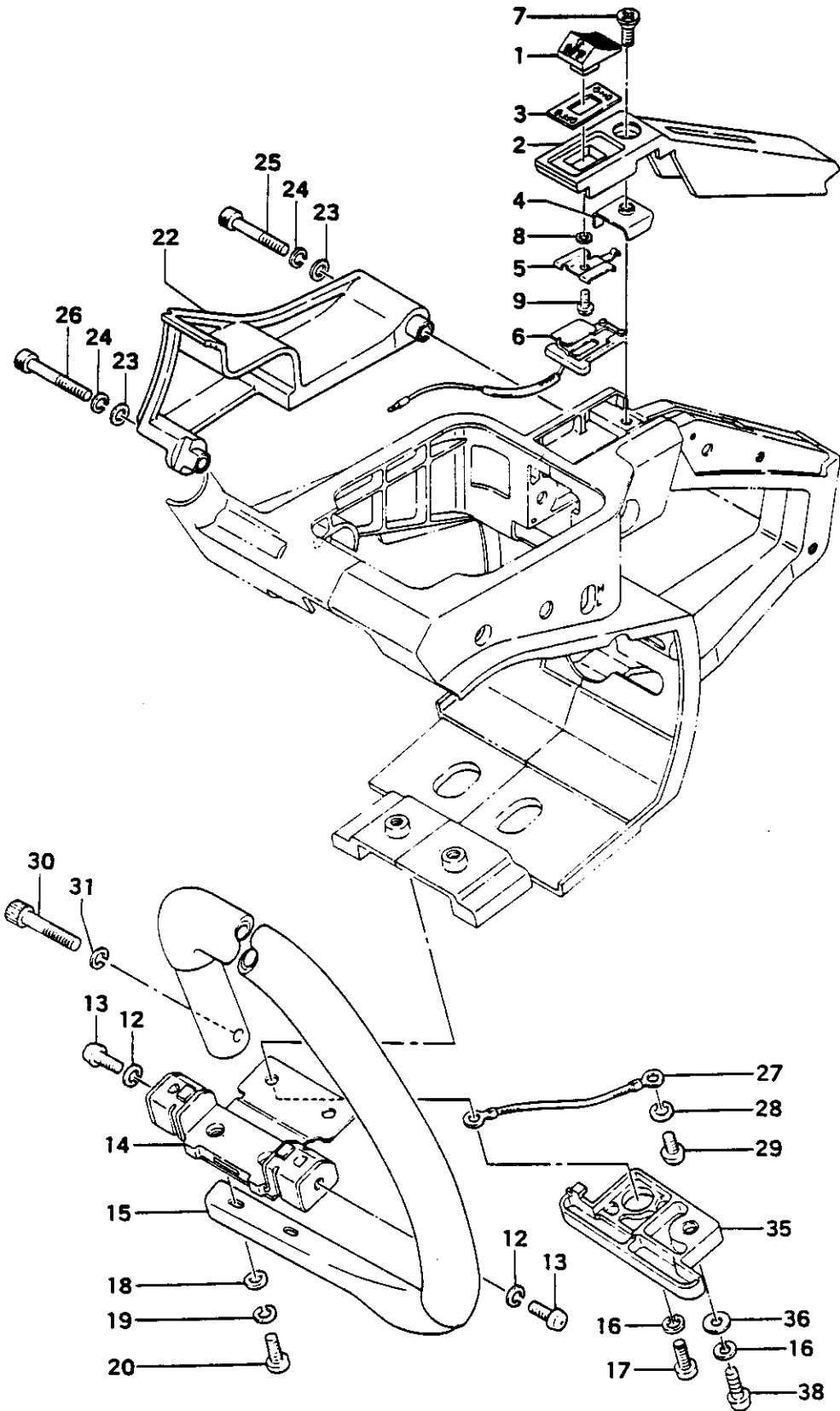

REFERENCE NUMBER	PRODUCTION PART NUMBER	PART NAME	QUANTITY	SERIAL NUMBER	SPARE PART NUMBER
FIG.6 HANDLE & STOP SWITCH					
6-001	258-04015-202	STOP BUTTON	1	258 0001	2
6-002	226-32050-200	HANDLE GRIP B	1	226 0060	2
6-003	925-32350-200	ON-OFF MARK	1	925 0040	8
6-004	272-04015-204	GROUND TERMINAL	1	272 0001	6
6-005	261-01800-201	STOP BUTTON TERMINAL	1	261 0010	4
6-006	178-01800-804	STUP CORD COMP.	1	178 0311	3
6-007	990-12050-151	F.H. SCREW 5X15	1	990 1181	3
6-008	992-00040-011	SMALL WASHER 4	1	992 0008	2
6-009	990-11040-061	SCREW 4X6	1	990 1025	4
6-012	992-10050-012	S.WASHER 5	2	992 1012	4
6-013	990-11050-121	SCREW 5X12	2	990 1065	2
6-014	219-32550-800	DAMPER FRONT COMP.	1	219 0140	9
6-015	209-32550-801	FRONT HANDLE COMP.	1	209 0120	2
6-016	992-10050-012	S.WASHER 5	2	992 1012	4
6-017	990-11050-121	SCREW 5X12	1	990 1065	2
6-018	992-01050-011	WASHER 5	2	992 0035	6
6-019	992-10050-012	S.WASHER 5	2	992 1012	4
6-020	990-11050-161	SCREW 5X16	2	990 1070	4
6-022	800-32350-802	REAR HAND GUARD	1	800 0081	3
6-023	992-00050-011	SMALL WASHER 5	2	992 0009	1
6-024	992-10050-012	S.WASHER 5	2	992 1012	4
6-025	990-51050-303	HEX. HOLE BOLT 5X30	1	990 5016	2
6-026	990-51050-403	HEX. HOLE BOLT 5X40	1	990 5018	0
6-027	274-01800-800	GROUND CORD COMP.	1	274 0000	1
6-028	992-10050-012	S.WASHER 5	1	992 1012	4
6-029	990-11050-101	SCREW 5X10	1	990 1062	5
6-030	990-51060-303	HEX. HOLE BOLT 6X30	1	990 5023	2
6-031	992-10060-012	S.WASHER 6	1	992 1019	7
6-035	797-32050-800	EARTH CORD COVER	1	797 0020	7
6-036	992-01050-011	WASHER 5	1	992 0035	6
6-038	990-11050-161	SCREW 5X16	1	990 1070	4

FIG.7 OIL PUMP

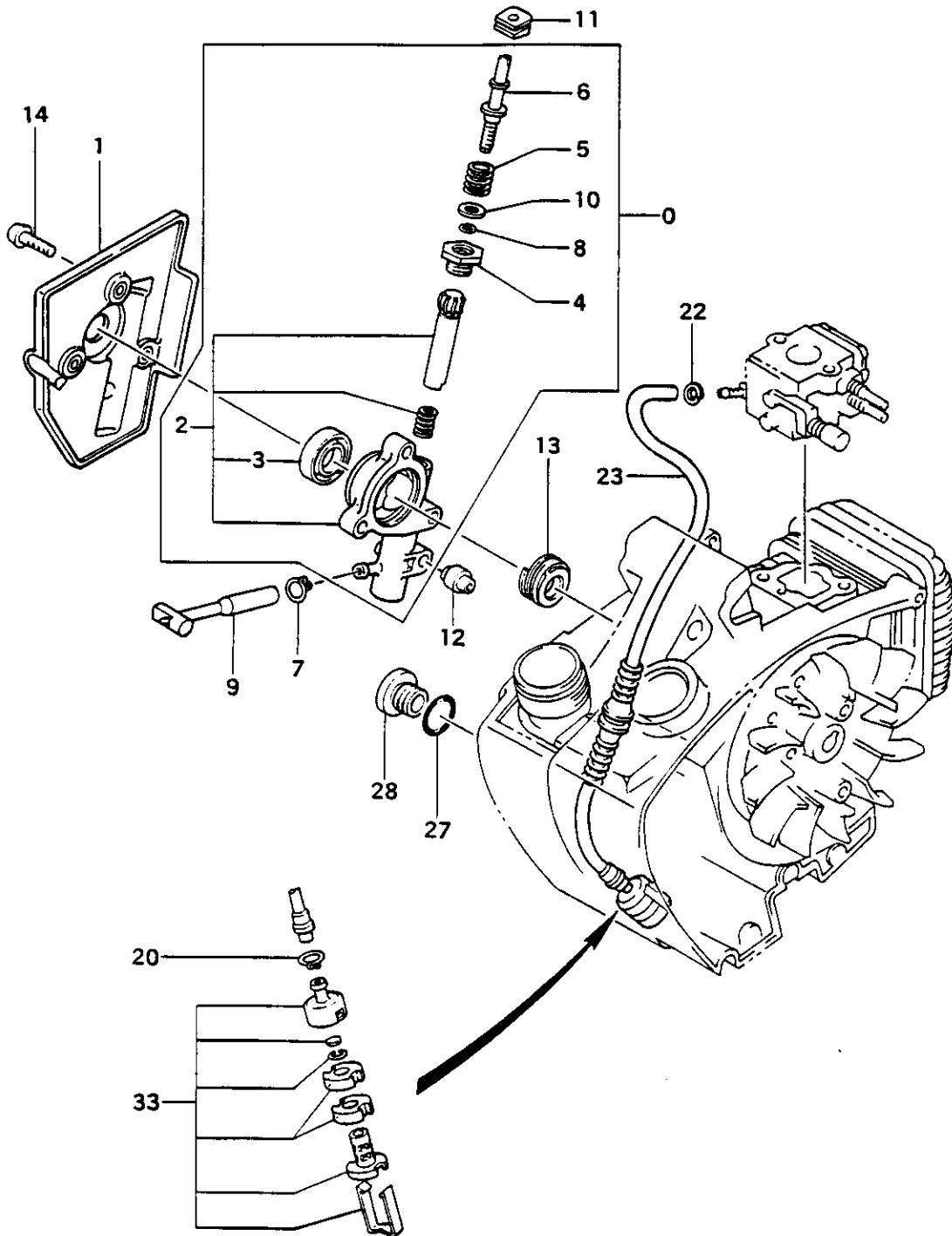

REFERENCE NUMBER	PRODUCTION PART NUMBER	PART NAME	QUANTITY	SERIAL NUMBER	SPARE PART NUMBER
FIG.7 OIL PUMP					
7-000	088-32550-910	OIL PUMP CASE ASS'Y	1		088 0110 0
7-001	097-32550-800	OIL PUMP COVER COMP.	1		097 0050 1
7-002	145-32550-800	OIL PUMP COMP.	1		145 0080 4
7-003	999-66132-420	OIL SEAL AC13246	1		999 6618 0
7-004	503-32550-200	OIL PUMP ADJUST CAP	1		503 0120 3
7-005	502-32550-200	ADJUSTER SPRING	1		502 0140 0
7-006	501-32550-200	OIL PUMP ADJUSTER	1		501 0190 8
7-007	680-03113-200	CLIP 7.5	1		680 0140 1
7-008	999-67005-000	O-RING P5	1		999 6703 1
7-009	515-32550-200	OIL PIPE A	1		515 0060 5
7-010	992-01050-011	WASHER 5	1		992 0035 6
7-011	488-32550-200	OIL ADJUST GROMMET	1		488 0120 1
7-012	622-00604-201	AIR PIPE	1		622 0020 0
7-013	084-32350-200	SCREW GEAR	1		084 0020 6
7-014	990-11050-221	SCREW 5X22	3		990 1080 1
7-020	680-04019-210	CLIP 7	1		680 0162 3
7-022	680-00731-201	CLIP	1		680 0080 6
7-023	678-04050-201	RUBBER PIPE	1		678 0270 8
7-C27	999-67012-500	O-RING P12.5	1		999 6715 6
7-G28	525-32350-201	OIL LEVEL CAP	1		525 0070 5
7-033	675-11610-901	PUMP FILTER BODY ASS'Y	1		675 0210 5

FIG.8 CARBURETOR

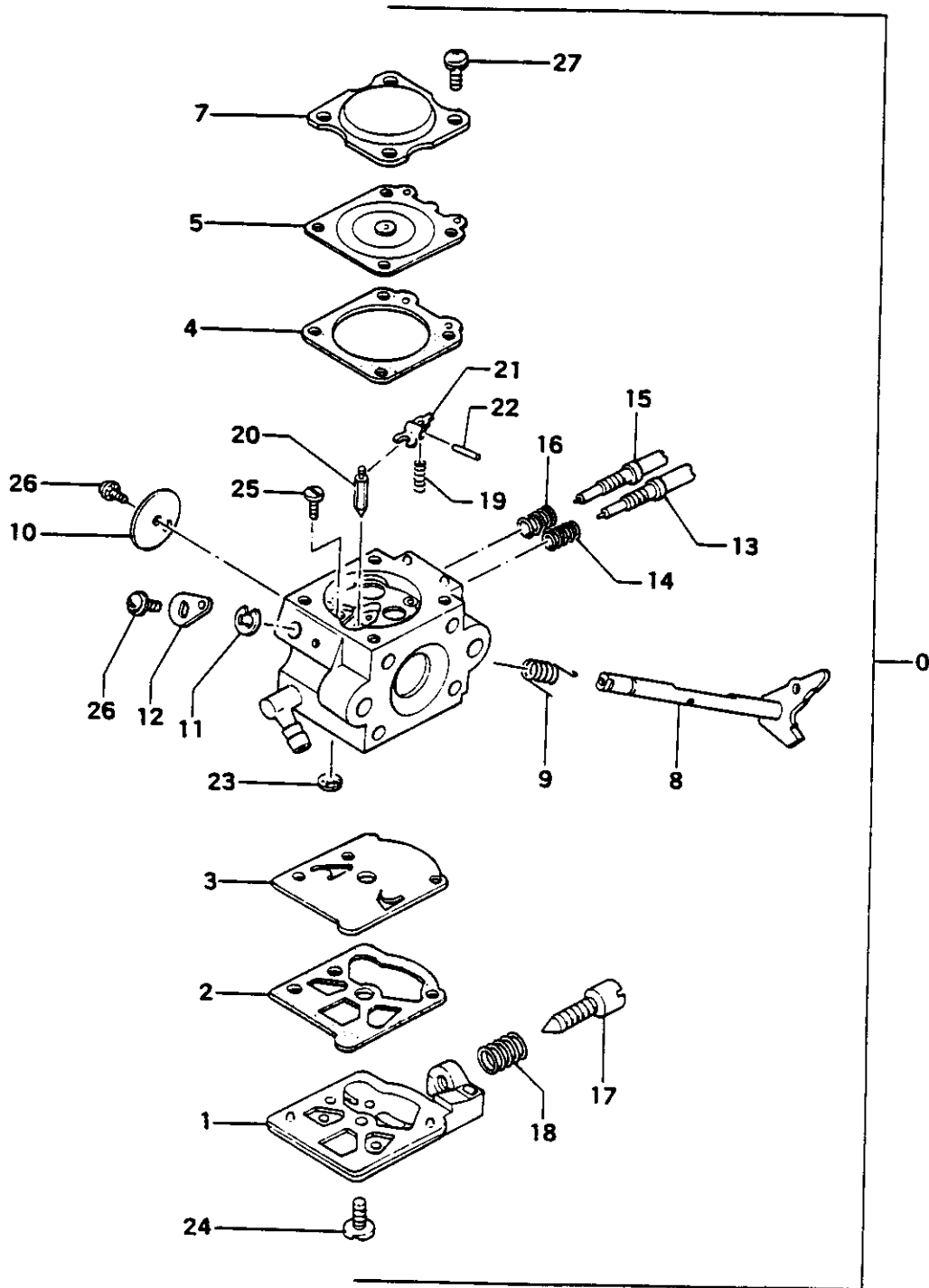

REFERENCE NUMBER	PRODUCTION PART NUMBER	PART NAME	QUANTITY	SERIAL NUMBER	SPARE PART NUMBER
FIG. 8 CARBURETOR					
8-000	455-25021-900	CARBURETOR ASS'Y	1	455 2340 9	
8-001	575-25010-200	PUMP BODY	1	575 0150 7	
8-002	577-25007-200	PUMP GASKET	1	577 0090 8	
8-003	576-25006-200	PUMP DIAPHRAGM	1	576 0070 7	
8-004	475-25001-200	DIAPHRAGM GASKET	1	475 0080 6	
8-005	474-25001-800	METERING DIAPHRAGM COMP.	1	474 0070 2	
8-007	476-25006-200	DIAPHRAGM COVER	1	476 0130 1	
8-008	464-25016-800	THROTTLE SHAFT COMP.	1	464 0140 1	
8-009	496-25007-200	THROTTLE SPRING	1	486 0060 2	
8-010	488-25012-200	THROTTLE VALVE	1	488 0100 7	
8-011	489-25007-200	STOP RING	1	489 0050 6	
8-012	491-25007-200	THROTTLE LEVER	1	491 0040 6	
8-013	460-25016-200	HIGH ADJUST SCREW	1	460 0260 0	
8-014	485-25003-200	HIGH ADJUST SPRING	1	485 0070 2	
8-015	461-25016-200	LOW ADJUST SCREW	1	461 0250 0	
8-016	623-25001-200	HIGH/LOW ADJUST SPRING	1	623 0170 5	
8-017	462-25016-200	IDLE ADJUST SCREW	1	462 0200 2	
8-018	463-25006-200	IDLE ADJUST SPRING	1	463 0070 2	
8-017	477-25007-200	VALVE SPRING	1	477 0080 0	
8-020	603-25001-200	NEEDLE VALVE	1	603 0290 6	
8-021	473-25001-200	VALVE HINGE	1	473 0060 8	
8-022	605-25001-200	HINGE PIN	1	605 0230 8	
8-023	578-25006-200	INLET SCREEN	1	578 0030 3	
8-024	514-25001-200	SET SCREW	1	514 0010 3	
8-025	546-25001-200	HINGE PIN SET SCREW	1	546 0030 0	
8-026	467-25003-200	SHUTTER SCREW	2	467 0010 8	
8-027	548-25014-200	SET SCREW	4	548 0040 1	

FIG.9 TOOLS

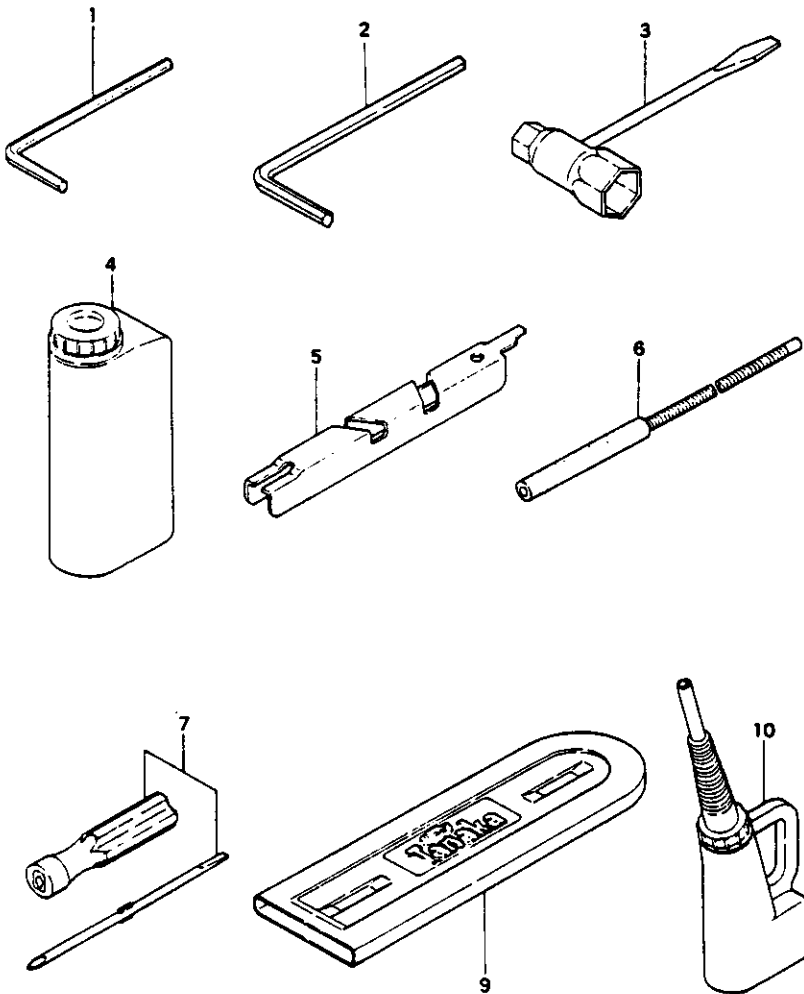

REFERENCE NUMBER	PRODUCTION PART NUMBER	PART NAME	QUANTITY	SERIAL NUMBER	SPARE PART NUMBER
FIG.9 TOOLS					
9-001	813-20000-200	HEX. WRENCH 4	1		813 0000 2
9-002	814-20000-200	HEX. WRENCH 5	1		814 0050 4
9-003	013-29323-501	COMBI BOX SPANNER 10X19	1		013 0280 6
9-004	872-20000-201	FUEL PREMIX CANISTER	1		872 0001 2
9-005	930-32057-200	DEPTH GAUGE	1		930 0150 6
9-006	936-20000-900	FILE ASS'Y 5/32	1		936 0020 4
9-006	894-32552-900	FILE ASS'Y 3/16	1		894 0130 7
9-007	901-32600-900	DRIVER ASS'Y	1		901 0020 0
9-009	946-32052-201	CHAIN COVER 14	1		946 0100 6
9-009	947-32055-201	CHAIN COVER 16	1		947 0110 0
9-010	840-32600-900	FUEL MIXING OILER ASS'Y	1		840 0060 2