

DS 50 Basic/Combi

Reservdelar

Spare parts

Ersatzteile

Pieces de rechange

Piezas de repuesto

Ricambi

Peças sobresselente

A

DS50 BASIC/COMBI

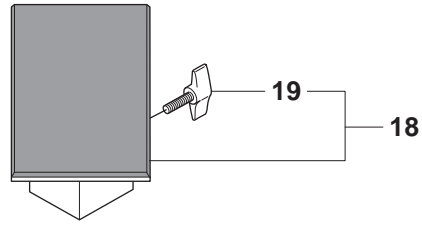

1

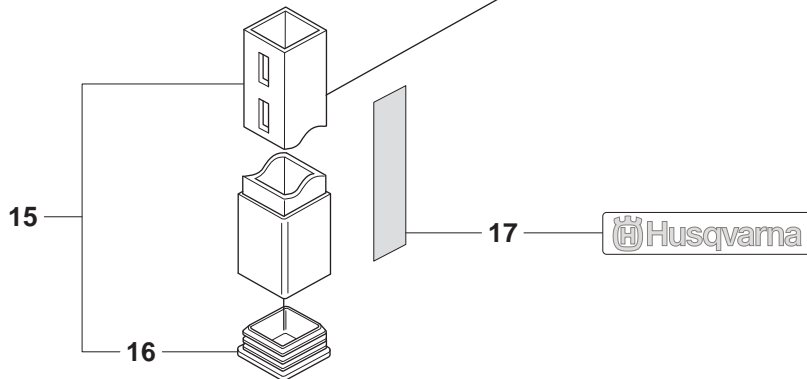
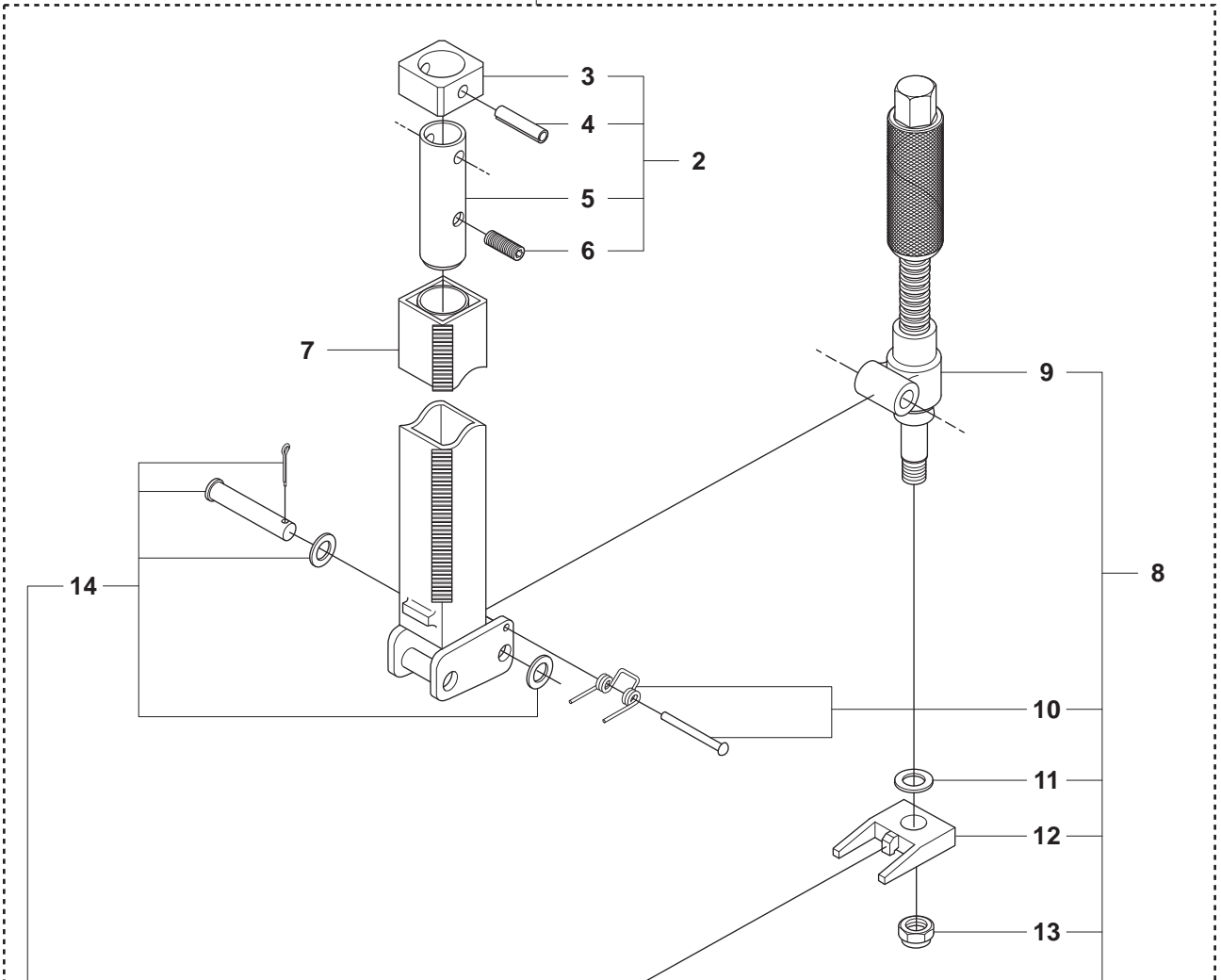

Page A**DS50 BASIC / COMBI**

Pos.	Part No.	Description	Quantity	Notes
1	506 40 83-05	EXPANDABLE COLUMN ASSY	1	Incl. 2, 7, 8, 15, 17
2	506 40 82-01	SLEEVE CPL	1	Incl. 3-6
3	531 14 07-53	STOP SLEEVE	1	
4	531 14 06-05	PIN	1	
5	531 14 06-06	STOP PIN	1	
6	531 14 06-07	SCREW	1	
7	506 40 04-01	PIPE OUTER	1	
8	506 40 81-05	ADJUSTER CPL	1	Incl. 9-14
9	506 40 81-07	ADJUSTER	1	
10	506 40 14-02	BOLT KIT	1	
11	531 14 06-13	WASHER	1	
12	531 14 06-16	FORK	1	
13	531 14 06-14	NUT	1	
14	506 40 14-01	BOLT KIT	1	
15	506 40 05-01	PIPE INNER	1	Incl. 16
16	531 14 06-20	PLUG	1	
17	504 02 10-02	DECAL	1	
18	506 40 84-06	TOP SUPPORT CPL	1	Incl. 19
19	531 14 06-02	WING SCREW	1	

B

DS50 BASIC/COMBI

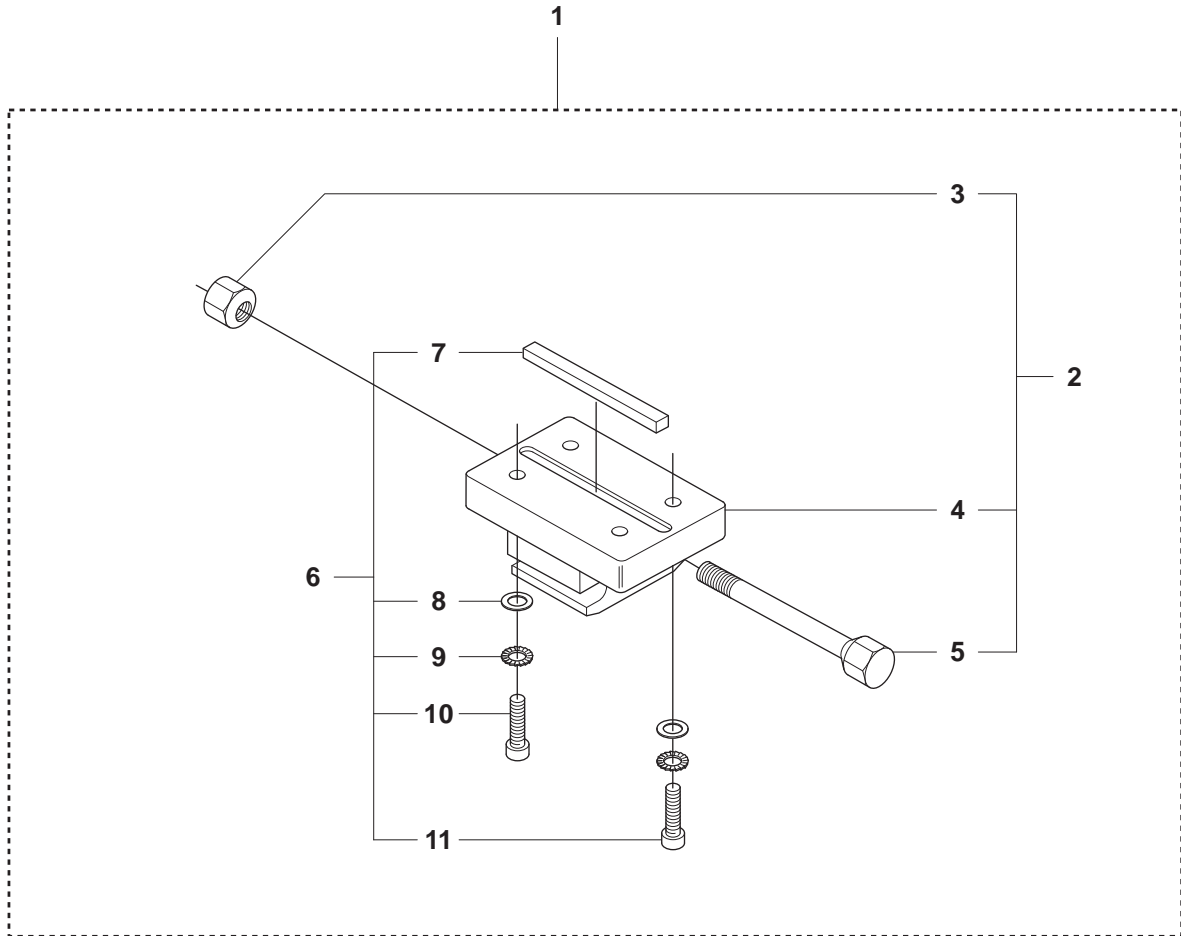

Page B**DS50 BASIC / COMBI**

Pos.	Part No.	Description	Quantity	Notes
1	506 40 08-03	MOTOR MOUNT 50 ASSY	1	Incl. 2, 6
2	506 40 08-04	MOTOR MOUNT 50 CPL	1	Incl. 3-5
3	531 14 06-83	NUT	1	
4	531 14 07-10	MOTOR MOUNT	1	
5	531 14 07-11	SCREW	1	
6	506 40 08-02	KEYSET CPL	1	Incl. 7-11
7	531 14 06-74	WEDGE	1	
8	531 14 07-12	WASHER	4	
9	531 14 07-13	WASHER	4	
10	531 14 06-81	SCREW	4	
11	531 14 07-14	SCREW	4	

C

DS50 BASIC/COMBI

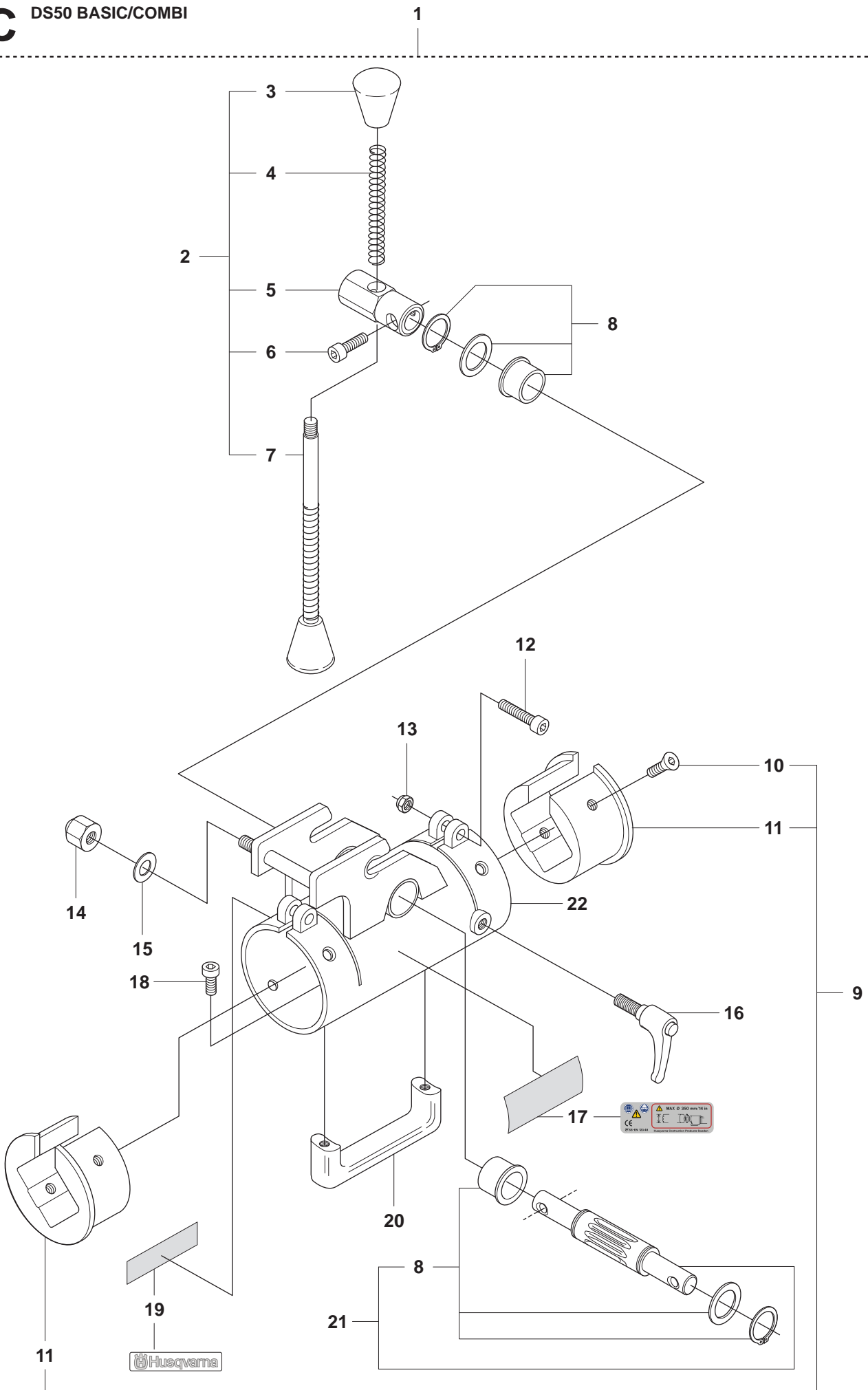

Page C**DS50 BASIC / COMBI**

Pos.	Part No.	Description	Quantity	Notes
1	506 40 90-07	DRILL CARRIAGE 50X1 ASSY	1	Incl. 2, 8, 9, 12-22
2	506 40 20-01	HANDLE CPL	1	Incl. 3-7
3	531 14 06-72	KNOB	2	
4	531 14 06-73	SPRING	2	
5	531 14 06-84	SLEEVE	1	
6	531 14 06-59	SCREW	1	
7	531 14 06-82	HANDLE	1	
8	506 40 19-01	BUSHING KIT	1	
9	506 40 89-02	BUSHING KIT	1	Incl. 10, 11
10	531 14 06-58	SCREW	8	
11	531 14 08-82	BUSHING	2	
12	531 14 06-86	SCREW	2	
13	531 14 06-30	NUT	2	
14	531 14 06-83	NUT	1	
15	531 14 06-11	WASHER	1	
16	506 40 77-08	ADJUSTABLE LEVER CPL	1	
17	544 12 85-02	DECAL	1	
18	531 14 06-85	SCREW	2	
19	504 02 10-01	DECAL	1	
20	544 21 89-01	HANDLE	1	
21	506 40 17-02	SHAFT CPL	1	Incl.8
22	504 02 22-01	DRILL CARRIAGE 50X1	1	

Page D**DS50 BASIC / COMBI**

Pos.	Part No.	Description	Quantity	Notes
1	506 40 84-06	TOP SUPPORT CPL	1	SEE ALSO PAGE A
2	506 40 83-05	EXPANDABLE COLUMN ASSY	1	SEE ALSO PAGE A
3	506 40 88-09	DRILL RACK BASIC ASSY	1	Incl. 4, 7
4	504 04 81-01	STOP SCREW 50 CPL	1	Incl. 5, 6
5	504 04 84-01	STOP SCREW	1	
6	504 04 82-01	WASHER	1	
7	544 03 01-01	DRILL RACK BASIC	1	
8	506 40 76-09	SHAFT HOLDER WITH WHEEL	1	Incl. 9-14
9	531 14 07-22	WASHER	1	
10	531 14 07-23	SCREW	1	
11	504 02 06-02	SHAFT HOLDER	1	
12	531 14 06-27	WASHER	6	
13	531 14 07-28	WHEEL	2	
14	531 14 07-30	COVER PLATE	2	
15	506 40 79-13	BASE PLATE BASIC NO WHEEL	1	Incl. 16-20
16	531 14 06-18	ADJUSTMENT SCREW	4	
17	544 06 97-01	LOCKING SCREW	1	
18	504 02 10-02	DECAL	1	
19	531 14 06-20	PLUG	4	
20	504 03 04-03	BASE PLATE BASIC	1	
21	506 40 80-14	BASE PLATE BASIC ASSY	1	

1

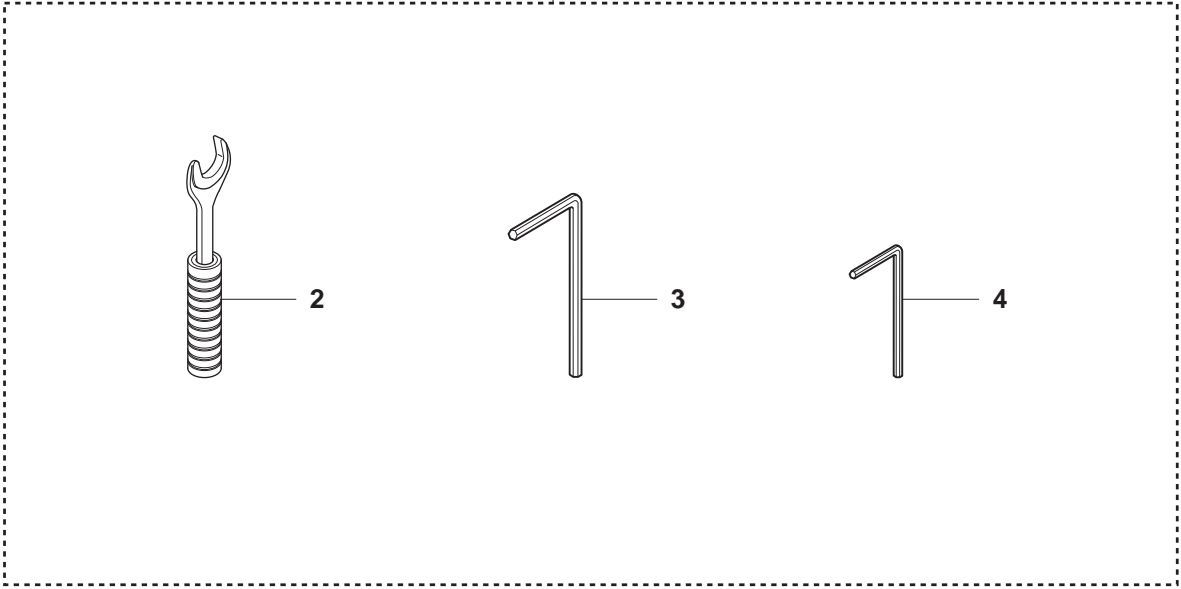

Page E

DS50 BASIC / COMBI

Pos.	Part No.	Description	Quantity	Notes
1	506 40 86-02	TOOL KIT	1	Incl. 2-4
2	544 22 27-02	SPANNER 24MM	1	
3	531 14 07-62	L ALLEN KEY 8MM	1	
4	544 27 98-01	L ALLEN KEY 6MM	1	