

ELECTRIC TOOL PARTS LIST

■ HAMMER DRILL
Model DH 24PC

1998·11·15
(E1)

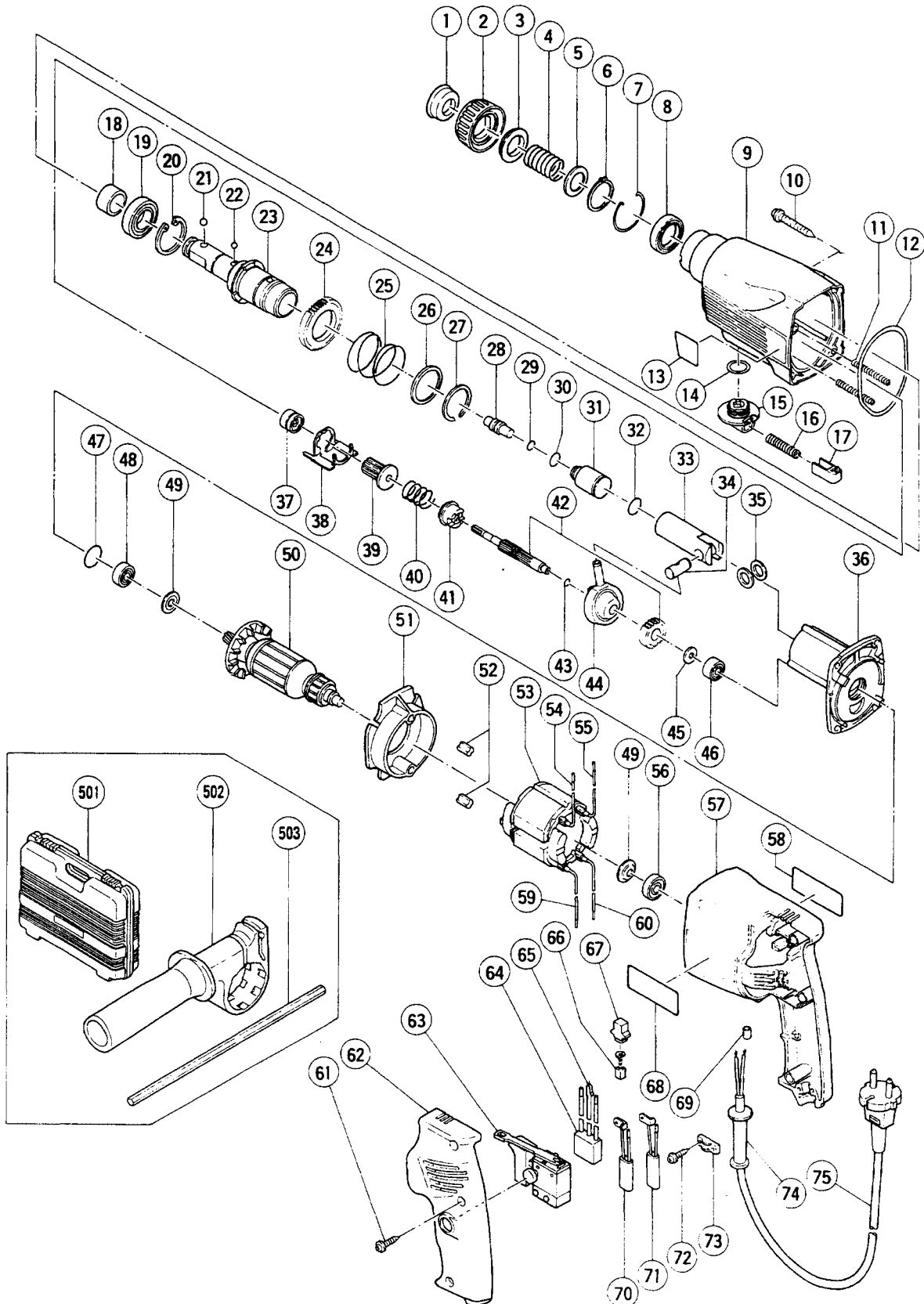

PARTS

DH 24PC

ITEM NO.	CODE NO.	DESCRIPTION	NO. USED	REMARKS
1	306-345	FRONT CAP	1	
2	317-229	GRIP	1	
3	317-230	BALL HOLDER	1	
4	306-342	HOLDER SPRING	1	
5	984-118	WASHER (B)	1	
6	939-547	RETAINING RING FOR D20 SHAFT (10 PCS.)	1	
7	317-236	RETAINING RING	1	
8	307-688	OIL SEAL	1	
9	317-221	GEAR COVER	1	
10	301-654	TAPPING SCREW (W/FLANGE) D5X35	4	
11	317-238	SPRING (B)	2	
12	314-881	O-RING	1	
13		THREE MODE LABEL	1	
14	878-885	O-RING (S-18)	1	
15	317-222	CHANGE LEVER	1	
16	317-223	PUSHING SPRING	1	
17	317-224	PUSHING BUTTON	1	
18	307-690	SLEEVE	1	
19	690-4CM	BALL BEARING 6904CM	1	
20	986-147	RETAINING RING FOR D37 HOLE	1	
21	959-156	STEEL BALL D7.0 (10 PCS.)	1	
22	959-154	STEEL BALL D5.556 (10 PCS.)	3	
23	317-231	CYLINDER	1	
24	317-232	SECOND GEAR	1	
25	317-233	SPRING (A)	1	
26	317-234	WASHER (A)	1	
27	317-235	RETAINING RING D30	1	
28	317-384	SECOND HAMMER	1	
29	301-672	O-RING (B)	1	
30	301-680	O-RING (FPM 810)	1	
31	315-148	STRIKER	1	
32	301-670	O-RING (A)	1	
33	301-668	PISTON	1	
34	301-666	PISTON PIN	1	
35	301-667	WASHER (C)	2	
36	314-880	INNER COVER	1	
37	317-240	PINION SLEEVE	1	
38	317-237	LOCK PLATE	1	
39	317-239	SECOND PINION	1	
40	317-227	CLUTCH SPRING	1	
41	317-228	CLUTCH	1	
42	317-226	GEAR.SHAFT SET	1	
43	992-912	O-RING (S-8)	1	
44	317-225	RECIPROCATING BEARING	1	
45	301-663	SPACER	1	
46	626-VVM	BALL BEARING 626VVMC2ERPS2S	1	
47	876-796	O-RING (P-22)	1	
48	608-DDM	BALL BEARING 608DDMC2EPS2S	1	
49	982-631	WASHER (A)	2	
* 50	360-446E	ARMATURE 220V-230V	1	
* 50	360-446F	ARMATURE 240V	1	

* : ALTERNATIVE PARTS

11 - 98

PARTS

DH 24PC

ITEM No.	CODE NO.	DESCRIPTION	NO. USED	REMARKS
* 50	360-446U	ARMATURE ASS'Y 110V-115V	1	INCLUD.48,49,56
51	314-879	FAN GUIDE ASS'Y	1	INCLUD.52
52	994-343	RUBBER BUSHING	2	
* 53	340-398C	STATOR 110V-115V	1	
* 53	340-398F	STATOR 240V	1	
54	314-914	INTERNAL WIRE (A) (BLACK)	1	
55	314-913	INTERNAL WIRE (A) (GRAY)	1	
56	608-VVM	BALL BEARING 608VVMC2EPS2L	1	
57	314-889	HOUSING	1	
58		NAME PLATE	1	
59	314-912	INTERNAL WIRE (A) (RED)	1	
60	314-915	INTERNAL WIRE (A) (WHITE)	1	
61	301-653	TAPPING SCREW (W/FLANGE) D4X20 (BLACK)	3	
62	314-891	HANDLE COVER	1	
* 63	314-916	SPEED CONTROL SWITCH (2P) 100V-115V	1	FOR TPE,GBR (110V),USA
* 63	314-921	SPEED CONTROL SWITCH (2P) 220V-240V	1	
* 64	994-273	NOISE SUPPRESSOR	1	FOR NZL,AUS,GBR,SAF,ITA,FRG,FRA,HOL,FIN, AUT,NOR,ESP,SUI,CHN,KOR
* 65	302-488	EARTH TERMINAL	1	FOR NOISE SUPPRESSOR
66	999-041	CARBON BRUSH (1 PAIR)	1	
66	999-072	CARBON BRUSH (AUTO STOP TYPE) (1 PAIR)	1	
67	955-203	BRUSH HOLDER	2	
68		HITACHI LABEL	1	
69	981-373	TUBE (D)	2	FOR CORD
* 70	314-917	INTERNAL WIRE (B) (BLUE)	1	FOR TPE,INA,SYR,SIN,HKG,KUW,USA
* 70	314-922	CHOKE COIL (A) BLUE	1	FOR NZL,AUS,GBR,SAF,ITA,FRG,FRA,HOL,FIN, AUT,NOR,ESP,SUI,CHN,KOR
* 71	314-918	INTERNAL WIRE (B) (BROWN)	1	FOR TPE,INA,SYR,SIN,HKG,KUW,USA
* 71	314-923	CHOKE COIL (A) BROWN	1	FOR NZL,AUS,GBR,SAF,ITA,FRG,FRA,HOL,FIN, AUT,NOR,ESP,SUI,CHN,KOR
72	984-750	TAPPING SCREW (W/FLANGE) D4X16	2	
73	937-631	CORD CLIP	1	
* 74	938-051	CORD ARMOR D10.1	1	
* 74	953-327	CORD ARMOR D8.8	1	
* 75	500-201Z	CORD	1	(CORD ARMOR D10.1) FOR TPE
* 75	500-409Z	CORD	1	(CORD ARMOR D8.8) FOR INA,KOR
* 75	500-245Z	CORD	1	(CORD ARMOR D10.1) FOR SYR
* 75	500-423Z	CORD	1	(CORD ARMOR D8.8) FOR SIN,KUW
* 75	500-439Z	CORD	1	(CORD ARMOR D8.8) FOR AUS,NZL
* 75	500-435Z	CORD	1	(CORD ARMOR D8.8) FOR HKG
* 75	500-454Z	CORD	1	(CORD ARMOR D8.8) FOR GBR (110V),SAF
* 75	500-390Z	CORD	1	(CORD ARMOR D10.1)
* 75	500-440Z	CORD	1	(CORD ARMOR D8.8) FOR GBR (230V)
* 75	500-391Z	CORD	1	(CORD ARMOR D10.1) FOR SUI
* 75	500-249Z	CORD	1	(CORD ARMOR D8.8) FOR USA
* 75	500-456Z	CORD	1	(CORD ARMOR D8.8) FOR CHN

STANDARD ACCESSORIES

DH 24PC

ITEM No.	CODE NO.	DESCRIPTION	NO. USED	REMARKS
501	307-786	CASE	1	
502	303-659	SIDE HANDLE	1	
* 503	303-709	DEPTH GAUGE	1	
* 503	310-331	DEPTH GAUGE	1	FOR USA

OPTIONAL ACCESSORIES

ITEM No.	CODE NO.	DESCRIPTION	NO. USED	REMARKS
601	306-369	DRILL BIT (SLENDER SHAFT) D3.4X90	1	
602	306-368	DRILL BIT (SLENDER SHAFT) D3.5X90	1	
603	306-370	ADAPTER FOR SLENDER SHAFT (SDS PLUS)	1	
604	944-460	TAPER SHANK DRILL BIT D11X100	1	
605	944-461	TAPER SHANK DRILL BIT D12.3X110	1	
606	993-038	TAPER SHANK DRILL BIT D12.7X110	1	
607	944-462	TAPER SHANK DRILL BIT D14.3X110	1	
608	944-500	TAPER SHANK DRILL BIT D14.5X110	1	
609	944-463	TAPER SHANK DRILL BIT D17.5X120	1	
610	944-464	TAPER SHANK DRILL BIT D21.5X140	1	
611	303-617	TAPER SHANK ADAPTER (SDS PLUS) NO.1	1	
612	303-618	TAPER SHANK ADAPTER (SDS PLUS) NO.2	1	
613	303-619	A-TAPER SHANK ADAPTER (SDS PLUS)	1	
614	303-620	B-TAPER SHANK ADAPTER (SDS PLUS)	1	
615	944-477	COTTER	1	
616	303-332	HAMMER DRILL CHUCK SET 13MM	1	INCLUD.617,618
617	303-334	CHUCK HANDLE	1	
618	303-335	RUBBER CAP	1	
619	302-976	ANCHOR SETTING ADAPTER A (SDS+)W1/4X260L	1	
620	302-975	ANCHOR SETTING ADAPTER A(SDS+)W5/16X260L	1	
621	303-621	ANCHOR SETTING ADAPTER A (SDS+)W3/8X160L	1	
622	302-974	ANCHOR SETTING ADAPTER A (SDS+)W3/8X260L	1	
623	302-979	ANCHOR SETTING ADAPTER B (SDS+)W1/4X260L	1	
624	302-978	ANCHOR SETTING ADAPTER B(SDS+)W5/16X260L	1	
625	303-622	ANCHOR SETTING ADAPTER B (SDS+)W3/8X160L	1	
626	302-977	ANCHOR SETTING ADAPTER B (SDS+)W3/8X260L	1	
627	971-794	ANCHOR SETTING ADAPTER A W1/4" (MANUAL)	1	
628	971-795	ANCHOR SETTING ADAPTER A W5/16" (MANUAL)	1	
629	971-796	ANCHOR SETTING ADAPTER A W3/8" (MANUAL)	1	
630	971-797	ANCHOR SETTING ADAPTER A W1/2" (MANUAL)	1	
631	971-798	ANCHOR SETTING ADAPTER A W5/8" (MANUAL)	1	
632	971-799	ANCHOR SETTING ADAPTER B W1/4" (MANUAL)	1	
633	971-800	ANCHOR SETTING ADAPTER B W5/16" (MANUAL)	1	
634	971-801	ANCHOR SETTING ADAPTER B W3/8" (MANUAL)	1	
635	971-802	ANCHOR SETTING ADAPTER B W1/2" (MANUAL)	1	
636	971-803	ANCHOR SETTING ADAPTER B W5/8" (MANUAL)	1	

* : ALTERNATIVE PARTS

