

ILLUSTRATED PARTS LIST

MODEL NO. 96051001400

CUSTOMER CATALOG NO. CTH126

PRODUCT NO. 960 51 00-14

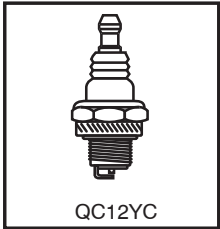
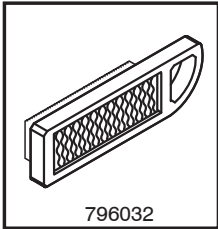

47

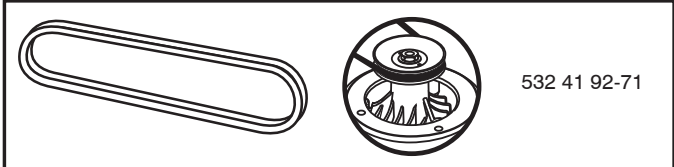
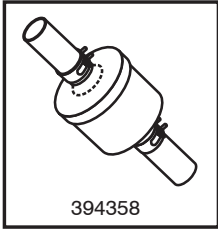

TRACTOR - - MODEL NO. CTH126 (96051001400), PRODUCT NO. 960 51 00-14
DECALS 27

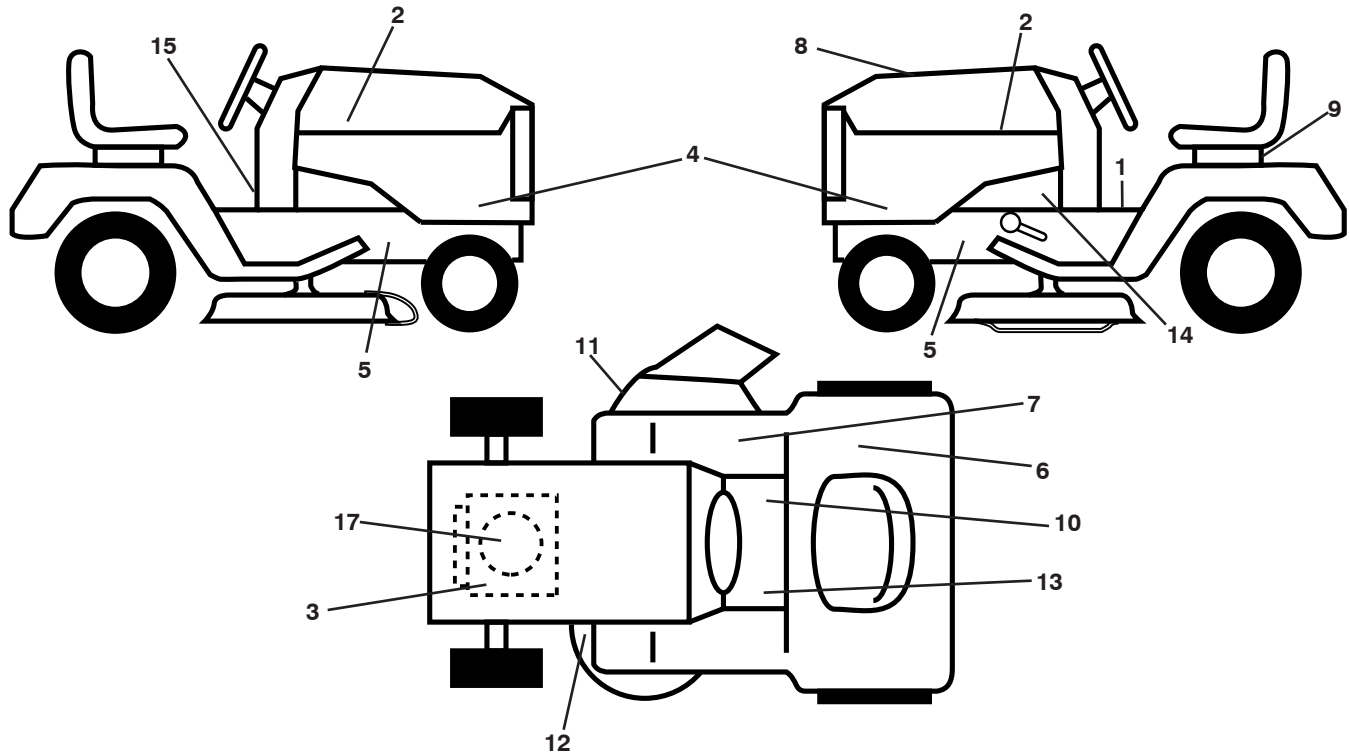

KEY NO.	PART NO.	DESCRIPTION
1	532 40 03-89	Decal, Operators
2	581 62 73-01	Decal, Hood Logo
3	532 19 68-41	Decal, Warning Eng. Symbols
4	532 43 99-54	Decal, Hood Panel
5	532 15 97-36	Decal, Chassis Hot Muffler
6	532 18 04-32	Decal, Fender 100 DB/CE
7	532 17 83-02	Decal, Oper Cruise Syms.
8	532 44 25-48	Decal, Rpl
9	532 14 50-05	Decal, Battery Dnge/Poi
10	532 14 08-37	Decal, Saddle Brake Parking

KEY NO.	PART NO.	DESCRIPTION
11	532 42 51-13	Decal, Warning DFlect/Cttingr
12	532 42 15-43	Decal, Mower V-Belt Schematic
13	532 15 97-37	Decal, Brake/Clutch Symbol
14	532 40 11-46	Decal, Warning
15	532 44 02-48	Decal, Instruction
17	532 43 74-10	Decal, BS Engine
--	532 16 69-60	Decal, Bypass
--	532 42 52-58	Pad, Footrest, LH
--	532 42 52-59	Pad, Footrest, RH
--	532 44 07-93	Manual Oper. Euro

WHEELS AND TIRES

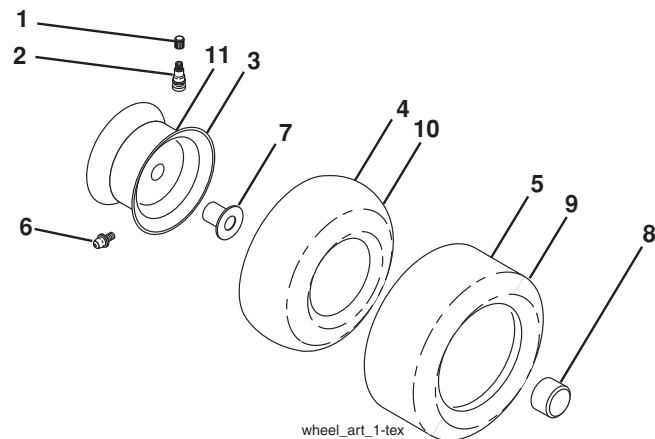

KEY NO.	PART NO.	DESCRIPTION
1	532 05 91-92	Cap Valve Tire
2	532 06 51-39	Stem Valve
3	532 42 52-61	Rim Asm 6 x 3.25 Front
4	532 42 16-52	TubeFront 13x5-6 (Service Item Only)
5	532 12 34-10	Tire F T 13 x 5.0 - 6
6	532 12 49-57	Fitting Grease (Front Wheel Only)
7	532 12 49-59	Bearing Flange (Front Wheel Only)
8	532 17 50-39	Cap Axle Blk 1 50 x 1 00
9	532 10 62-30	Tire R 16 x 6.5
10	532 00 71-54	Tube Rear (Service Item Only)
11	532 42 52-62	Rim Asm 8 x 5.375 Rear
--	532 14 43-34	Sealant, Tire (10 oz. Tube)

NOTE: All component dimensions given in U.S. inches
 1 inch = 25.4 mm

TRACTOR - - MODEL NO. CTH126 (96051001400), PRODUCT NO. 960 51 00-14

SCHEMATIC 38

SCH19

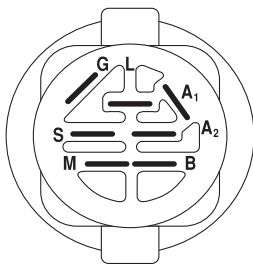
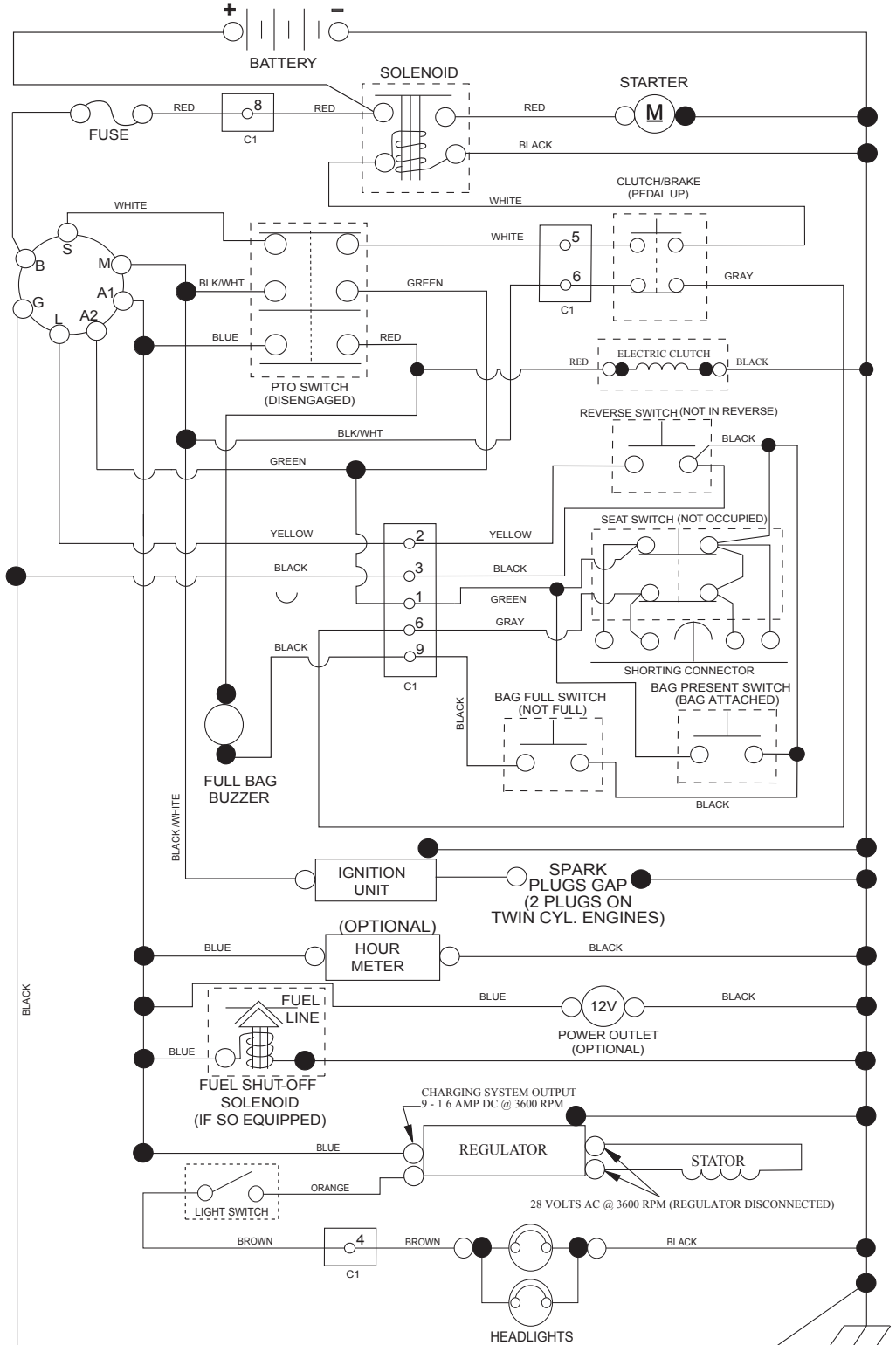

IGNITION SWITCH

POSITION	CIRCUIT	"MAKE"
OFF	M+G+A1	
RUN/OVERRIDE	B+A1	
RUN	B+A1	L+A2
START	B + S + A1	

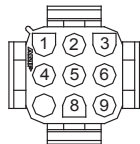

CHASSIS HARNESS CONNECTOR (C1) (MATING SIDE)

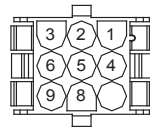

DASH HARNESS CONNECTOR (C1) (MATING SIDE)

WIRING INSULATED CLIPS
NOTE: IF WIRING INSULATED CLIPS WERE REMOVED FOR SERVICING OF UNIT, THEY SHOULD BE RE-INSTALLED TO PROPERLY SECURE YOUR WIRING.

●
NON-REMOVABLE CONNECTIONS

○
REMOVABLE CONNECTIONS

TRACTOR - - MODEL NO. CTH126 (96051001400), PRODUCT NO. 960 51 00-14
ELECTRICAL **32**

S04S

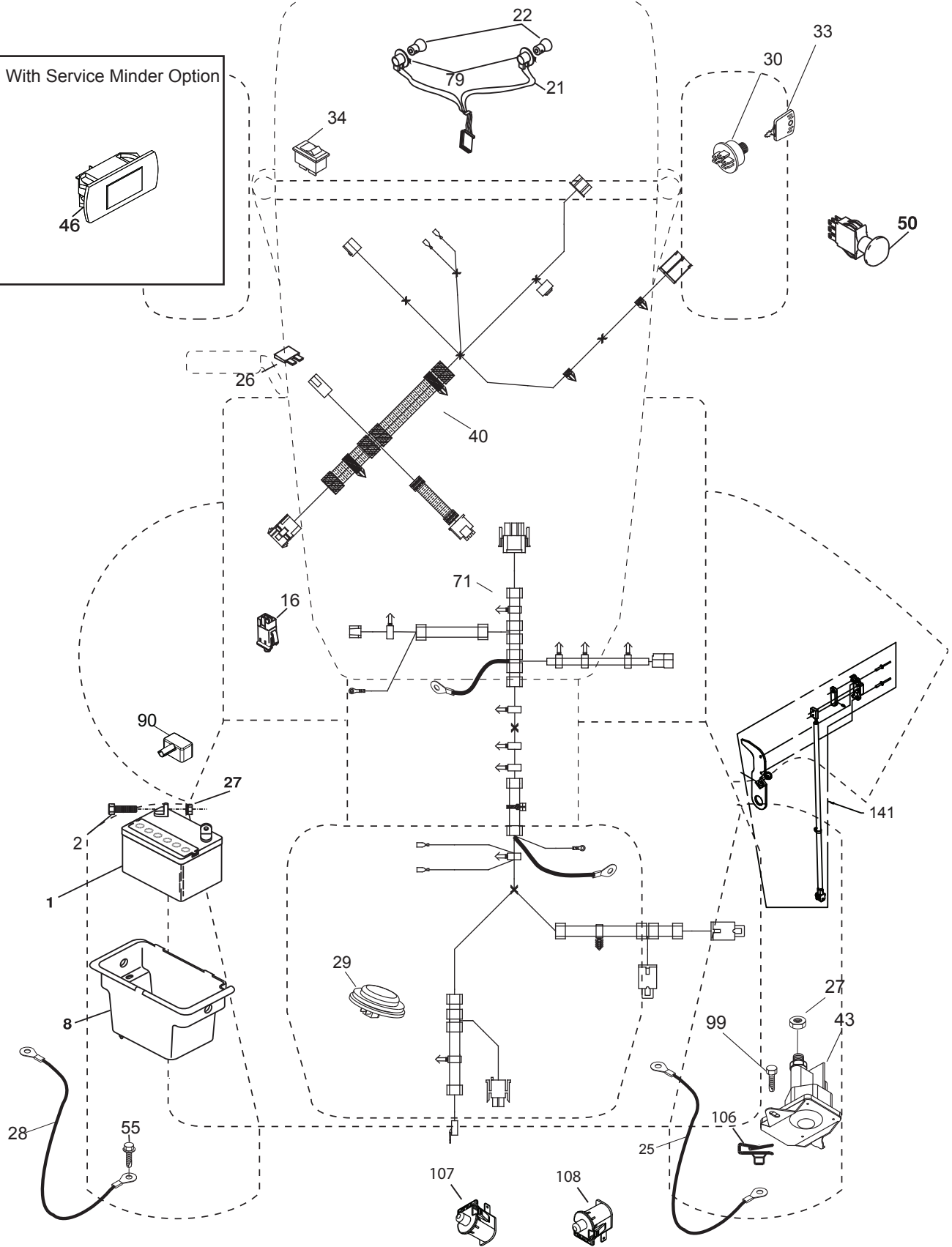
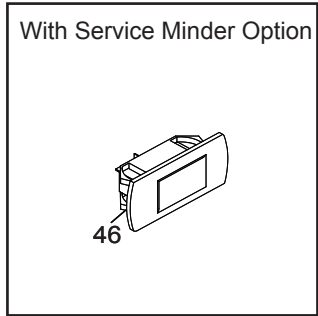

**TRACTOR - - MODEL NO. CTH126 (96051001400), PRODUCT NO. 960 51 00-14
ELECTRICAL 32**

KEY NO.	PART NO.	DESCRIPTION
1	532 16 34-65	Battery
2	874 76 04-12	Bolt Hex Head 1/4-20 x 3/4
8	532 41 97-91	Box Battery
16	532 17 61-38	Switch Interlock Push-In
21	532 40 02-52	Harness Socket Light w/4152J
22	532 00 41-52	Bulb Light
25	532 41 66-94	Cable Starter
26	532 17 51-58	Fuse
27	873 51 04-00	Nut Keps Hex 1/4-20 unc
28	532 42 16-86	Cable, Ground
29	532 40 15-45	Switch, Seat
30	532 19 33-50	Switch, Ign
33	532 41 19-35	Key/Chain
34	532 11 07-12	Switch Light/Reset
40	532 42 95-33	Harness Ign. Dash
43	532 19 25-07	Solenoid
46	532 40 17-63	Gauge
50	532 17 46-51	Switch PTO
55	817 06 05-12	Screw Thdrol 5/16-18 x 3/4 TYTT
71	532 42 94-12	Harness Ign. Chassis
79	532 17 52-42	Socket Asm. Bulb
90	532 43 53-95	Cover Terminal
99	817 67 04-12	Screw 1/4-20 x 3/4
106	532 17 48-14	Nut Speed 1/4-20
107	532 42 10-61	Switch Snapmount No #2
108	532 42 10-62	Switch Snapmount NC
141	532 41 69-77	Kit T2 ROS

NOTE: All component dimensions given in U.S. inches
1 inch = 25.4 mm

TRACTOR - - MODEL NO. CTH126 (96051001400), PRODUCT NO. 960 51 00-14
CHASSIS AND ENCLOSURES **39**

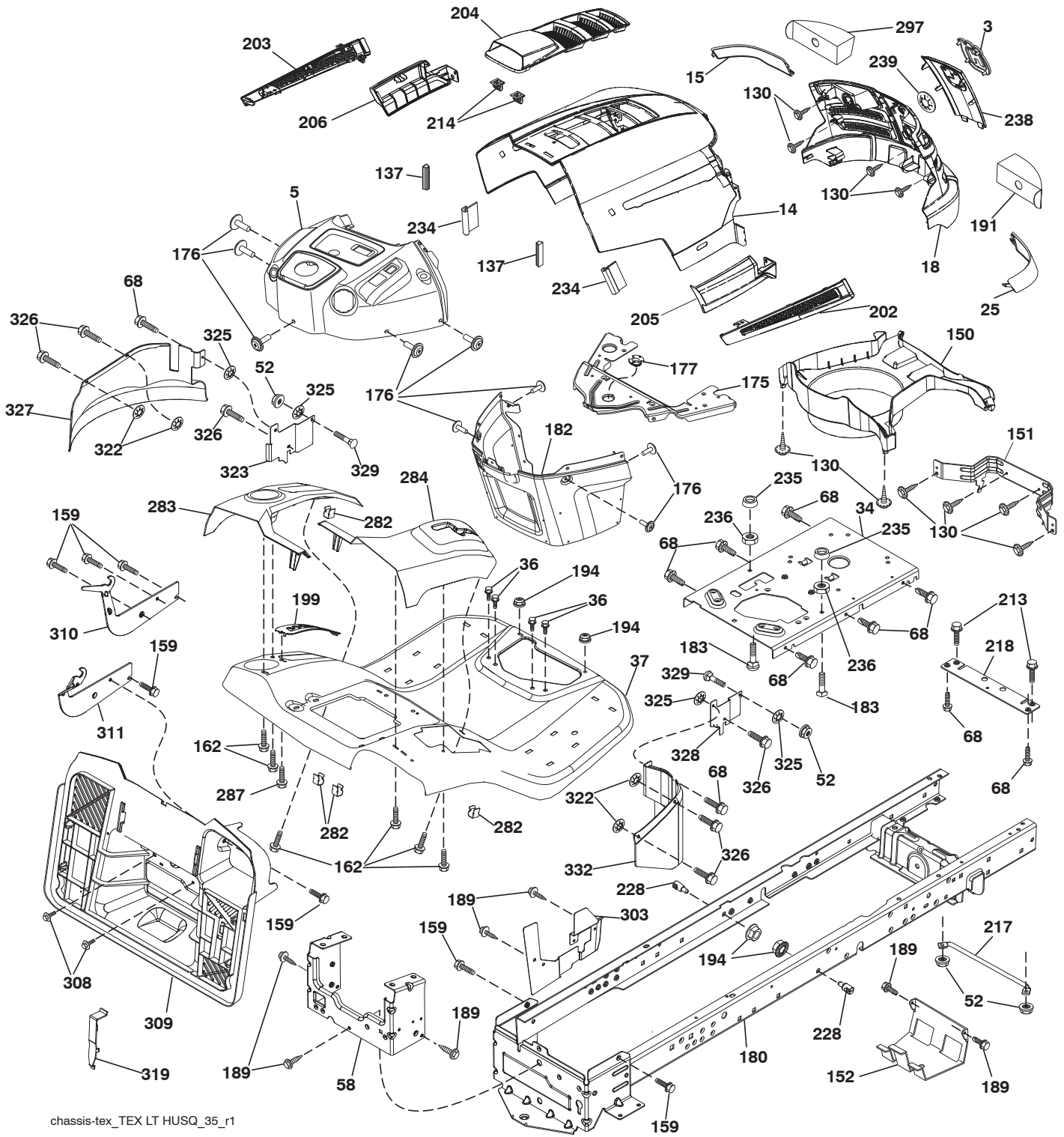

chassis-tex_TEX LT HUSQ_35_r1

**TRACTOR - - MODEL NO. CTH126 (96051001400), PRODUCT NO. 960 51 00-14
CHASSIS AND ENCLOSURES **39****

KEY NO.	PART NO.	DESCRIPTION	KEY NO.	PART NO.	DESCRIPTION
3	532 40 50-12	Logo	213	874 76 05-12	Bolt 5/16-18 x 3/4
5	532 40 75-94	Dash	214	532 19 91-45	Clip Retainer
14	532 41 10-73	Hood	217	532 40 91-67	Rod Pivot Hood
15	532 41 10-79	Lens LH	218	532 19 63-95	X-Piece Hood Stop
18	532 42 69-63	Grille	228	532 19 51-61	Stud Fastener
25	532 41 10-78	Lens RH	234	532 40 47-42	Bumper Hood
34	532 19 61-25	Plate Engine	235	532 40 61-29	Spacer Fender
36	817 06 05-12	Screw 5/16-18 x 3/4	236	873 93 05-00	Nut Lock 5/16-18 unc
37	532 44 11-08	Fender	238	532 41 11-19	Trim
52	873 68 05-00	Nut Crown Lock 5/16	239	532 40 48-83	Clip Tinnerman
58	532 41 22-80	Drawbar Upper	282	532 41 41-10	Clip Retainer
68	817 49 05-08	Screw Thdrol. 5/16-18 x 1/2	283	532 44 05-31	Console Deck Lift
130	532 41 63-58	Screw #10 x 0.750 BOS Thread	284	532 44 05-30	Console Shift
137	532 40 75-90	Bumper Dash	287	817 60 04-06	Screw Hex Washhead 1/4-20 x 3/8
150	532 40 66-62	Air Duct	297	532 40 66-65	Insert Reflective LH
151	532 40 78-07	Bracket Pivot	303	532 42 51-51	Shield Chassis French
152	532 19 95-35	Shield Browning	308	532 17 18-77	Bolt 5/16-18 unc x 3/4
159	817 00 06-12	Screw Kexwsh Thdr 3/8-16 x 3/4	309	532 43 02-46	Backplate Bagger SRD
162	532 14 24-32	Screw Hex Wsh. Hi-Lo 1/4 x 1/2 unc	310	532 44 66-36	Bracket Hangar Bag LH
175	532 19 94-72	Crossmember	311	532 44 66-37	Bracket Hangar Bag RH
176	532 40 07-76	Screw 10-24 x 5/8	319	532 17 46-62	Bracket Actuator Bagger
177	532 19 52-28	Bushing Steering	322	532 42 30-62	Palnut 1/4
180	532 41 46-85	Chassis	323	532 43 14-88	Guard French
182	532 40 71-76	Dash Lower	325	532 42 30-63	Palnut 5/16
183	874 52 05-20	Bolt 5/16-18 x 1-1/4	326	817 06 04-10	Screw Hex
189	817 00 05-12	Screw 5/16-18 x 3/4	327	532 43 14-83	French Guard
191	532 41 65-01	Insert Reflective RH	328	532 43 14-87	French Guard
194	873 90 05-00	Nut Lock Hex Flange 5/16-18	329	872 14 05-05	Bolt 5/16-18 x 5/8
199	532 41 87-39	Plate Deck Lift	332	532 43 14-82	French Guard
202	532 41 10-75	Vent Side Hood RH			
203	532 41 10-74	Vent Side Hood LH			
204	532 44 11-16	Vent Top Hood			
205	532 41 10-76	Skirt Side RH			
206	532 41 10-77	Skirt Side LH			

NOTE: All component dimensions given in U.S. inches
1 inch = 25.4 mm

TRACTOR - - MODEL NO. CTH126 (96051001400), PRODUCT NO. 960 51 00-14
DRIVE **40**

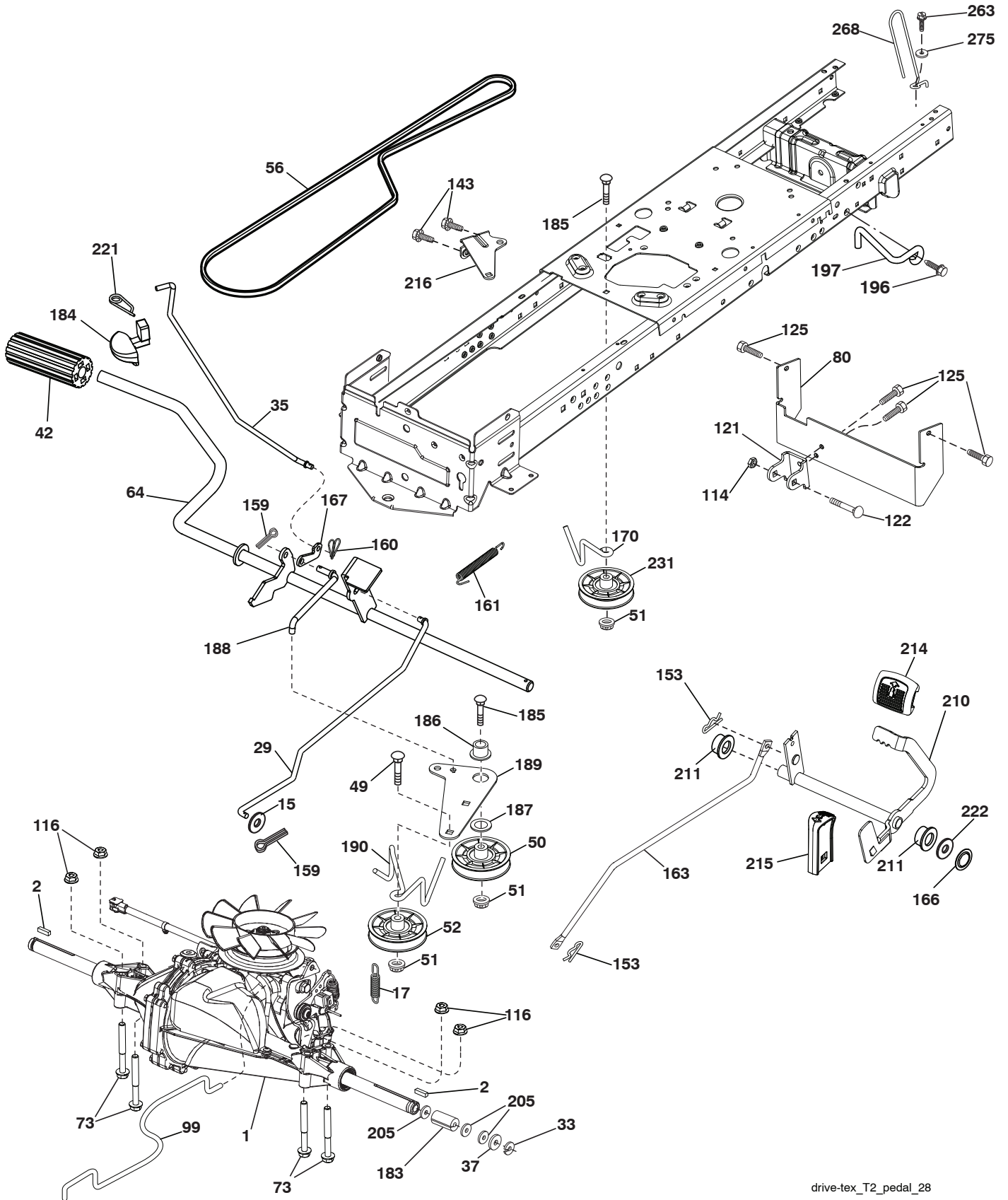

drive-tex_T2_pedal_28

**TRACTOR - - MODEL NO. CTH126 (96051001400), PRODUCT NO. 960 51 00-14
DRIVE **40****

KEY NO.	PART NO.	DESCRIPTION
1	---	Transaxle, Hydro Gear T2-BABC-1X2B-1GX1 (421645) (Order parts from transaxle manufacturer.)
2	532 12 35-83	Key Square
15	819 13 13-16	Washer 13/32 x 13/16 x 16 Ga.
17	532 19 72-96	Spring, Brake
29	532 42 32-39	Rod, Brake
33	812 00 00-01	Ring E
35	532 40 10-31	Rod, Brake, Park
37	532 12 17-49	Washer 25/32 x 1-1/4 x 16 Ga.
42	532 12 48-72	Cover, Foot Pedal
49	872 11 06-14	Bolt
50	532 19 43-27	Pulley Idler Flat
51	873 90 06-00	Lock Nut 3/8-16
52	532 19 43-26	Idler V-Groove
56	532 12 59-07	V-Belt, Drive
64	532 19 78-65	Shaft Asm. Pedal Brake Control
73	874 49 05-44	Bolt Hex 5/16-18 Gr. 5
80	581 55 07-01	Strap Torque
99	532 40 84-18	Rod Spring Bypass
114	873 80 05-00	Nut Lock 5/16-18 unc
116	873 90 05-00	Nut Lock Hex Flange 5/16-18
121	532 17 56-11	Bracket Strap Torque
122	872 01 05-20	Bolt 5/16-18 x 2.50
125	817 00 05-12	Screw 5/16-18 x 3/4
143	817 49 05-08	Screw THDROL 5/16-18 x 1/2
153	532 12 47-88	Retainer Spring 1"
159	876 02 04-12	Pin Cotter 1/8 x 3/4
160	532 16 94-84	Retainer Clip

KEY NO.	PART NO.	DESCRIPTION
161	532 10 57-09	Spring, Return, Clutch
163	532 41 33-22	Rod Control
166	532 42 91-64	Nut Push .625
167	532 40 52-57	Latch Brake Parking
170	532 41 34-30	Keeper Belt Centerspan
183	532 15 69-72	Spacer Axle
184	532 40 97-47	Handle Parking Brake
185	872 11 06-22	Bolt
186	532 19 43-21	Spacer Retainer
187	819 13 32-10	Washer
188	532 19 43-23	Link Clutch Ground Drive
189	532 19 43-17	Bellcrank Ground Drive
190	532 19 43-18	Keeper Bellcrank Ground Drive
196	817 00 06-16	Screw 3/8-16 x 1
197	532 19 58-04	Link Clutch Anti-Rotation
205	532 12 17-48	Washer 25/32 x 1-5/8 x 16 Ga.
210	532 40 09-80	Rocker Asm. Pedal Control
211	532 12 01-83	Bearing Nylon
214	532 42 12-63	Pedal Pad Forward
215	532 41 94-82	Pedal Reverse
216	532 19 61-31	Bracket Pulley Idler
221	532 40 31-87	Retainer Spring Clip Handle
222	879 21 20-10	Washer 21/32 x 1-1/4 10 Ga.
231	532 40 72-87	Idler V-Groove 1.688" Offset
263	817 00 06-12	Screw Hexwsh THDR 3/8-16 x 3/4
268	532 18 24-02	Guard, Muffler
275	819 13 16-14	Washer

NOTE: All component dimensions given in U.S. inches
1 inch = 25.4 mm

**TRACTOR - - MODEL NO. CTH126 (96051001400), PRODUCT NO. 960 51 00-14
ENGINE 24**

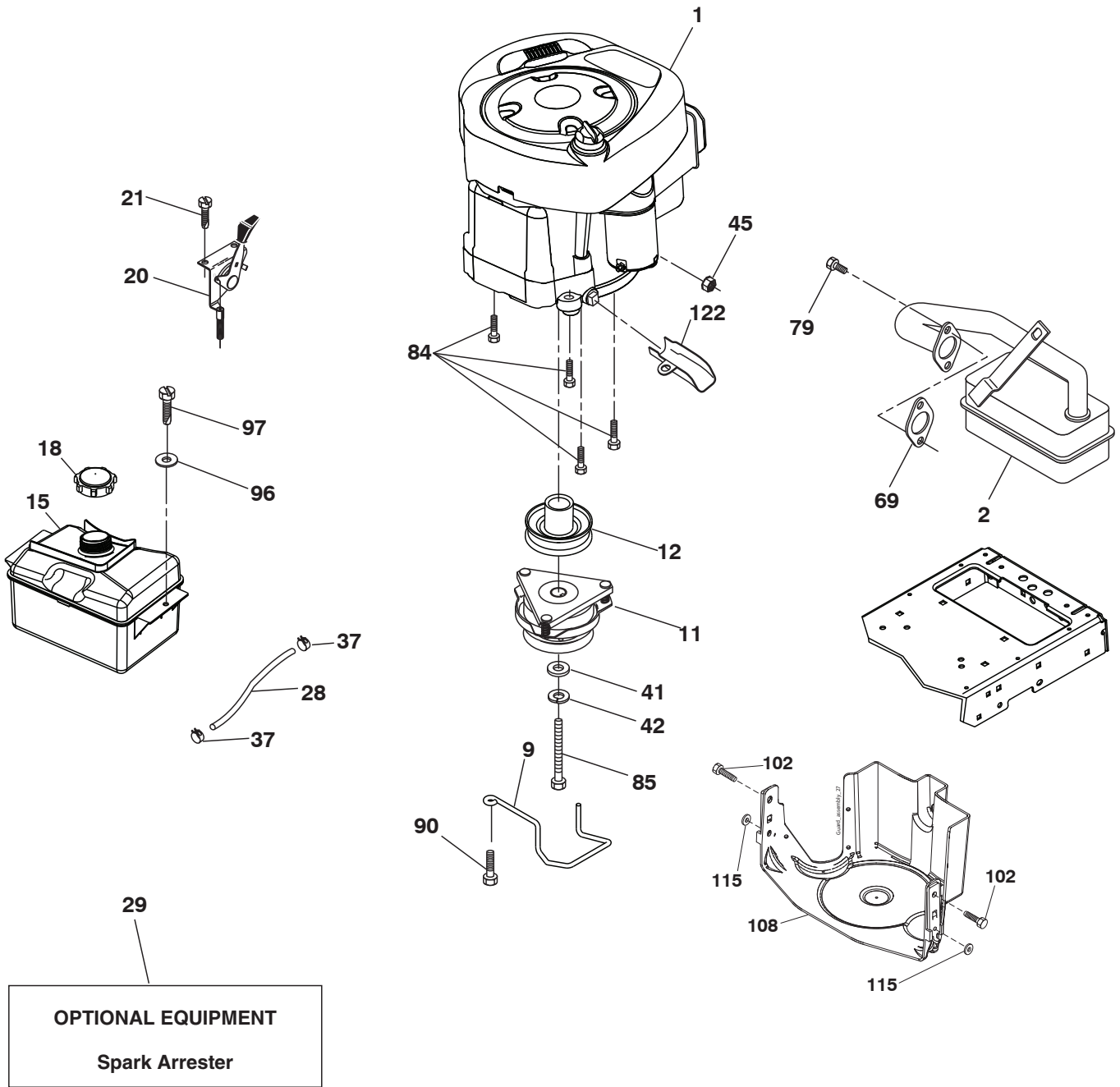

engine-tex_BS_32

**TRACTOR - - MODEL NO. CTH126 (96051001400), PRODUCT NO. 960 51 00-14
ENGINE 24**

KEY NO.	PART NO.	DESCRIPTION
1	— — — — —	Engine BS Model No. 219807-3376-B1 (436172) (Order parts from engine manufacturer.)
2	532 17 97-58	Muffler
9	532 19 43-19	Keeper Belt Engine
11	532 18 05-05	Clutch
12	532 19 43-38	Pulley Engine
15	532 40 75-45	Tank Fuel 1.5
18	532 43 02-20	Cap Asm
20	532 18 38-97	Control Throttle
21	532 41 63-58	Screw #10 x 0.750 BOS Thread
28	532 13 70-40	Fuel Line
29	532 13 71-80	Spark Arrester Kit
37	532 12 34-87	Clamp Hose
41	532 12 61-97	Washer 1-1/2 x 15-32 x .250
42	810 04 07-00	Washer Lock Hvy HLCL SPR 7/16
45	873 51 04-00	Nut Keps Hex 1/4-20 unc
69	532 16 52-91	Gasket
79	532 19 23-34	Screw Socket HD 5/16 - 18 x 75
84	817 06 06-20	Screw 3/8-16 x 1-1/4
85	532 17 39-37	Bolt Hex 7/16-20 x 4 Gr. 5-1.5
90	817 00 06-16	Screw 3/8-16 x 1
96	819 09 14-16	Washer 9/32 x 7/8 x 16 Ga.
97	817 67 04-12	Screw 1/4-20 x 3/4
102	817 00 05-12	Screw 5/16-18 x 3 x 4
108	532 43 16-89	Pulley Cover Engine
115	532 42 30-62	Palnut 1/4
122	532 42 19-22	Extension Drain Oil

NOTE: All component dimensions given in U.S. inches
1 inch = 25.4 mm

Engine Power Rating Information

The gross power rating for individual gas engine models is labeled in accordance with SAE (Society of Automotive Engineers) code J1940 (Small Engine Power & Torque Rating Procedure), and rating performance has been obtained and corrected in accordance with SAE J1995 (Revision 2002-05). Torque values are derived at 3060 RPM; horsepower values are derived at 3600 RPM. Actual gross engine power will be lower and is affected by, among other things, ambient operating conditions and engine-to-engine variability. Given both the wide array of products on which engines are placed and the variety of environmental issues applicable to operating the equipment, the gas engine will not develop the rated gross power when used in a given piece of power equipment (actual "on-site" or net power). This difference is due to a variety of factors including, but not limited to, accessories (air cleaner, exhaust, charging, cooling, carburetor, fuel pump, etc.), application limitations, ambient operating conditions (temperature, humidity, altitude), and engine-to-engine variability. Due to manufacturing and capacity limitations, Briggs & Stratton may substitute an engine of higher rated power for this Series engine.

TRACTOR - - MODEL NO. CTH126 (96051001400), PRODUCT NO. 960 51 00-14
STEERING ASSEMBLY [41]

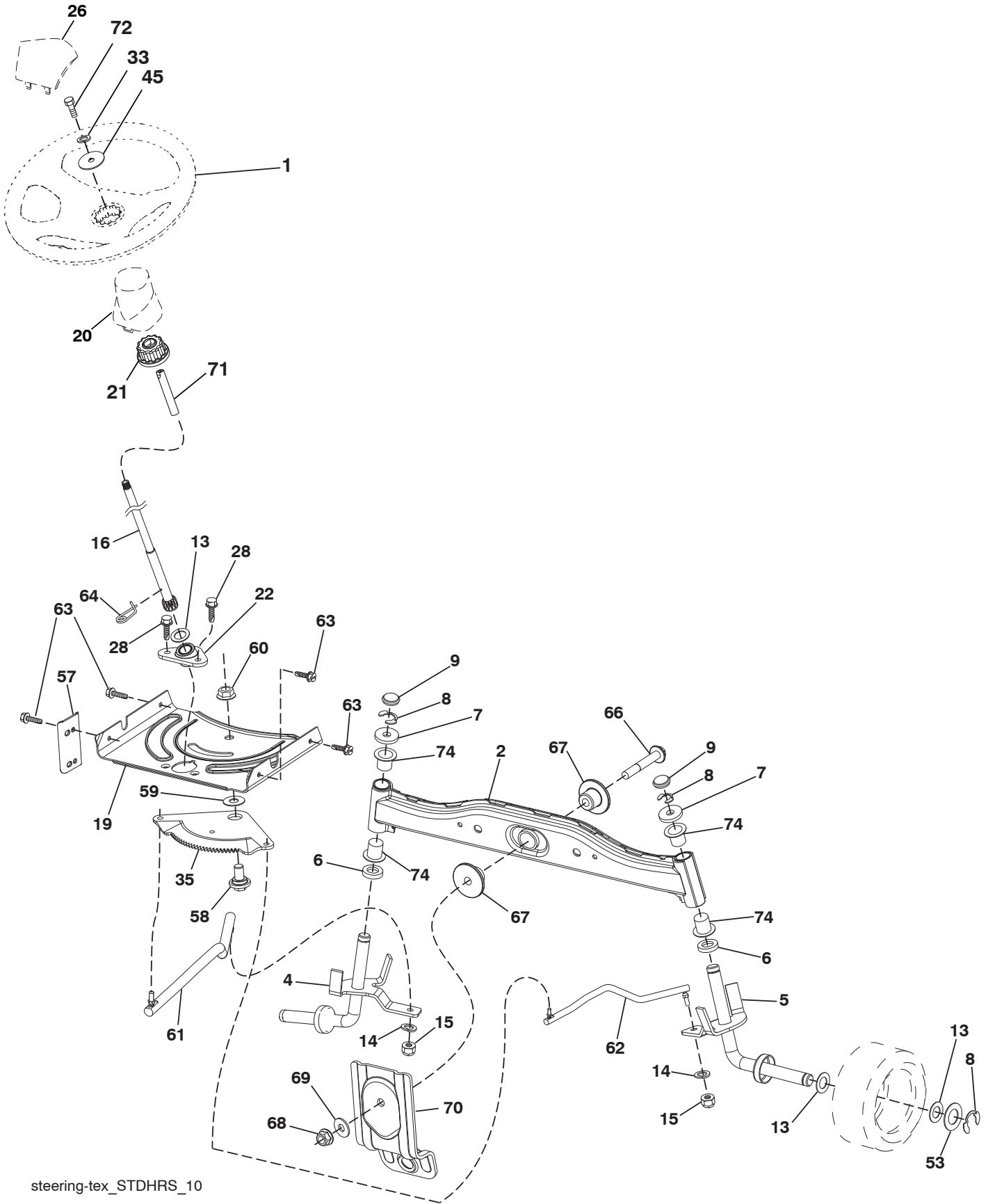

steering-tex_STDHRS_10

TRACTOR - - MODEL NO. CTH126 (96051001400), PRODUCT NO. 960 51 00-14
STEERING ASSEMBLY 41

KEY NO.	PART NO.	DESCRIPTION
1	532 41 64-80	Wheel, Steering Husq SR
2	532 41 81-68	Axle Asm., Front
4	532 41 68-45	Spindle Asm., LH
5	532 41 68-46	Spindle Asm., RH
6	532 12 49-31	Bearing, Race Thrust Hardened
7	532 12 17-48	Washer 25/32 x 1-5/8 x 16 Ga.
8	812 00 00-29	Ring, Klip #T5304-75
9	532 12 12-32	Cap, Spindle
13	532 12 17-49	Washer, 25/32 x 1-1/4 x 16 Ga.
14	810 04 06-00	Washer, Lock Hvy Hlcl Spr 3/8
15	873 54 06-00	Nut, Crown Lock 3/8-24 unf
16	532 42 93-73	Shaft Steering
19	532 19 47-29	Plate Steering
20	532 44 11-13	Boot, Steering
21	532 18 67-37	Adapter, Wheel Steering
22	532 42 05-37	Steering Support Lower
26	532 41 59-87	Insert, Wheel Steering Husq SR
28	817 00 06-12	Screw 3/8-16 x 3/4
33	810 04 05-00	Washer Lock 5/16
35	532 19 47-32	Gear, Sector Plate
45	819 11 38-12	Washer 11/32 x 3/8 x 12 Ga.
53	532 18 89-67	WasherHardened.793x1.637x.060
57	532 40 74-65	Bracket Upstop
58	532 19 47-47	Bolt Shoulder Sector Pivot CFM
59	532 19 47-48	Washer Thrust Sector Steering
60	873 97 10-00	Nut Flange Lock 5/8-11
61	532 19 47-40	Draglink, LH
62	532 19 47-41	Draglink, RH
63	817 00 05-12	Screw 5/16-18 x 3/4
64	532 19 98-49	Retainer Clip Spring Steering
66	871 02 07-48	Bolt Hex Fghd 7/16-14 x 3 Serr
67	532 19 47-37	Bushing PM Front Axle
68	873 90 07-00	Nut Lock Flange 7/16-14 Gr. 5
69	532 19 91-62	Washer 1.5 x .505 x .118
70	532 41 70-65	Bracket Deck Susp. Front
71	532 19 07-52	Shaft Extension Steering
72	532 42 89-82	Bolt Fin Hex 5/16-18 x 4 w/Patch
74	532 12 49-37	Bearing

NOTE: All component dimensions given in U.S. inches
1 inch = 25.4 mm

TRACTOR - - MODEL NO. CTH126 (96051001400), PRODUCT NO. 960 51 00-14
MOWER DECK 44

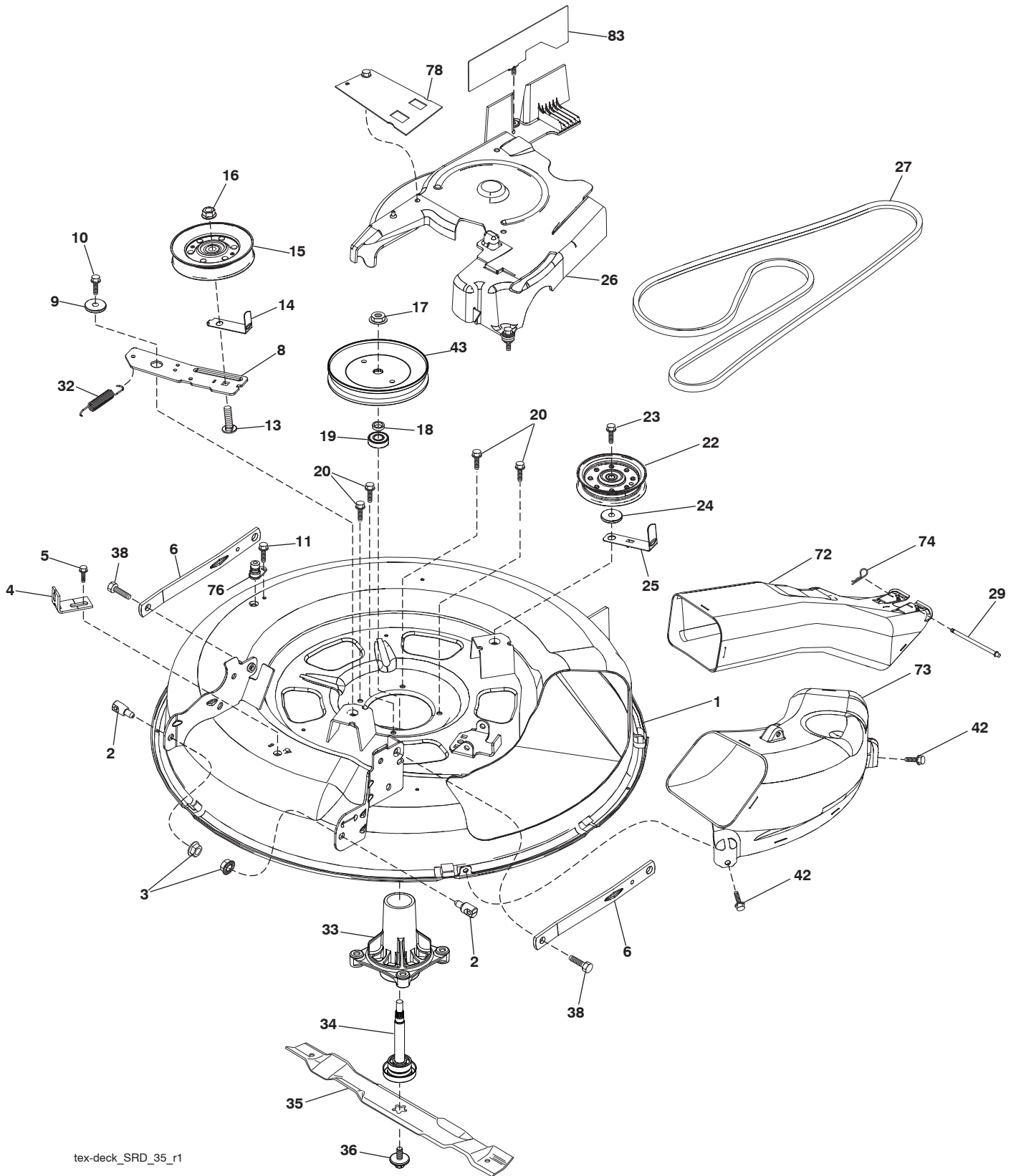

tex-deck_SRD_35_r1

**TRACTOR - - MODEL NO. CTH126 (96051001400), PRODUCT NO. 960 51 00-14
MOWER DECK 44**

KEY NO.	PART NO.	DESCRIPTION	KEY NO.	PART NO.	DESCRIPTION
1	532 41 92-72	Deck Weldment 30" Srd	34	532 19 28-72	Shaft Asm Mndrl N/Greaseable 38
2	532 19 51-61	Stud Fastner W/'D'anti-Rotatio	35	532 41 92-74	Blade
3	873 90 05-00	Nut Lock Hex Flange 5/16-18	36	532 19 30-03	Bolt/Washer Asm 7/16 - 20 unf
4	532 41 76-45	Bracket Clutch Cable	38	532 19 65-39	Bolt Shoulder
5	817 00 05-10	Bolt 5/16-18	42	817 00 06-12	ScrewHexwshTHDR3/8-16x3/4BL
6	532 41 88-63	Arm Susp Mower Rear Srd	43	532 41 68-77	Pulley Mandrel 6 5 Pd 30"
8	532 42 02-52	Arm Idler 30" Srd	72	532 41 72-36	Chute Upper SRD 30R
9	532 19 90-92	Spacer Retainer	73	532 42 52-74	Chute Lower SRD 30R
10	817 00 06-16	Screw 3/8 - 16 x 1 Smgml Tap/R Blk	74	532 12 46-70	Retainer Spring
11	532 13 77-29	Screw Thd Roll 1/4 - 20 x 5/8	76	532 41 55-98	Washout Port
13	872 11 06-12	Bolt Carr Sh 3/8-16 x 1-1/2 Gr. 5	78	532 42 25-66	Deck Guard
14	532 15 60-85	Keeper Belt Idler	83	532 43 24-67	Assy Shield
15	532 14 67-63	Pulley Idler V-Groove Dim 4.25	--	532 43 60-87	Bungee Kit
16	873 90 06-00	Nut Lock FIG 3/8 - 16 unc	--	532 19 28-70	Mandrel Assembly (Includes Hous- ing, Shaft Assembly, And Bearing Only - Pulley/Nut/Washer And Blade Bolt/Washers Not Included)
17	532 40 02-34	Nut Flange Lock Top			
18	532 18 76-90	Washer Spacer Mandrel			
19	532 11 04-85	Bearing Ball Mandrel			
20	532 17 39-84	Screw Thd Roll Dod Pt Hex	--	532 44 10-76	Replacement Mower Complete
22	532 19 31-98	Pulley Idler Flat Unplated			
23	817 49 06-28	Screw Thdrol 3/8-16 x 1-3/4			
24	819 13 20-12	Washer 13/32 x 1-1/4 x 12 Ga			
25	532 42 02-53	Keeper Belt 30" Srd			
26	532 43 24-66	Cover Mandrel Mwr 30"Black			
27	532 41 92-71	V-Belt Drive			
29	532 42 08-95	Hinge Pin			
32	532 19 72-51	Spring Mower Drive			
33	532 18 72-81	Housing Mandrel 4pt Service			

NOTE: All component dimensions given in U.S. inches
1 inch = 25.4 mm

TRACTOR - - MODEL NO. CTH126 (96051001400), PRODUCT NO. 960 51 00-14
MOWER LIFT 45

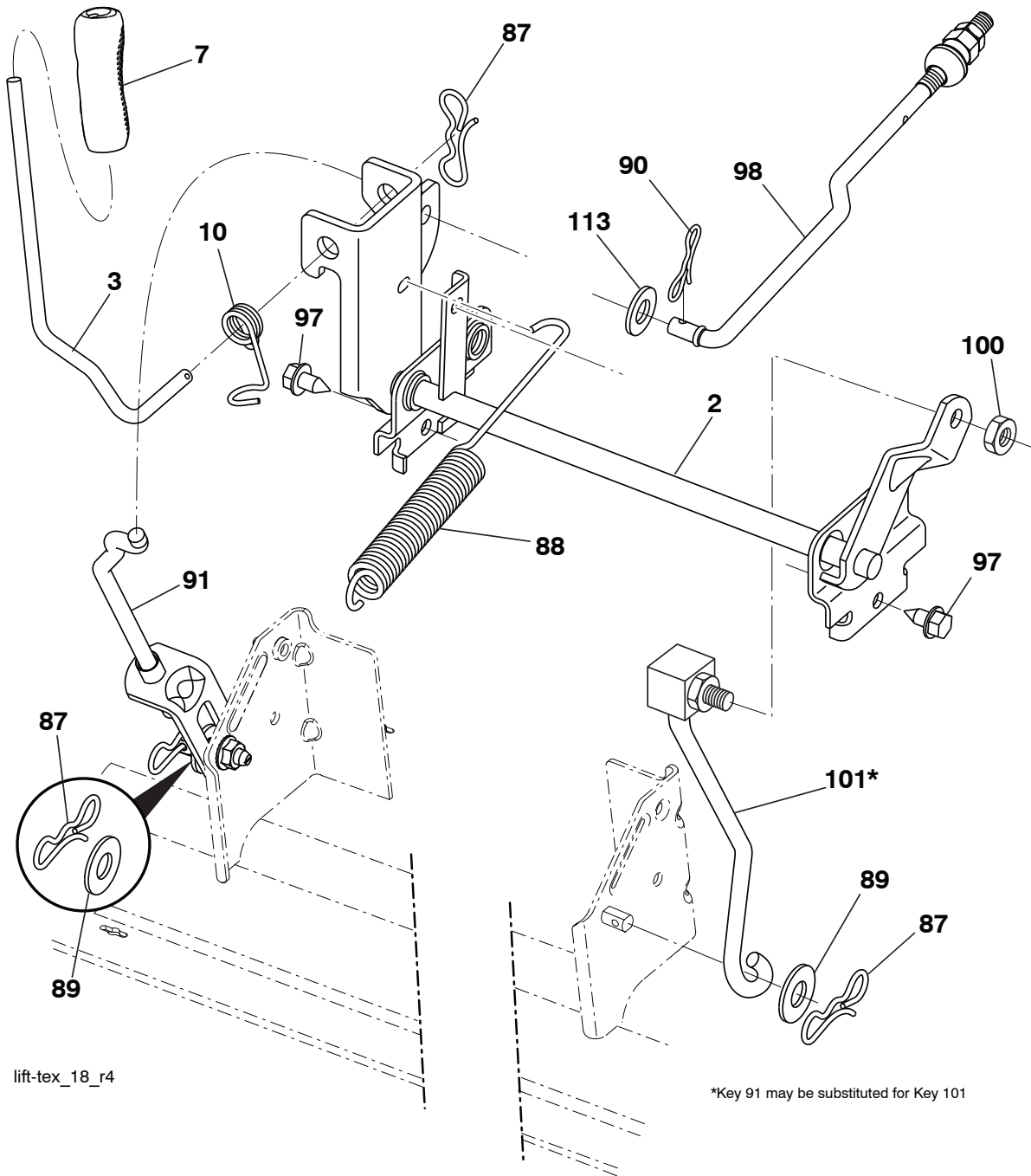

lift-tex_18_r4

*Key 91 may be substituted for Key 101

KEY NO.	PART NO.	DESCRIPTION
2	532 42 20-27	Shaft Asm., Lift
3	532 19 52-31	Lever Asm., Lift RH
7	532 41 15-55	Grip, Lever
10	532 19 63-14	Spring Torsion
87	532 19 42-09	Pin Cotter 7/16 Bow Tie Lock
88	532 41 07-10	Spring Lift Assist
89	819 19 19-12	Washer Clear
90	532 19 42-08	Pin Cotter 5/16 Bow Tie Lock
91	532 19 51-81	Link Lift Susp Mower Rear

KEY NO.	PART NO.	DESCRIPTION
97	817 00 06-12	Screw 3/8-16 x 3/4
98	532 19 52-64	Link Lift Susp. Front Mower
100	873 93 06-00	Nut Centerlock 3/8-16
101	532 40 70-03	Link Asm. Lift Fixed
113	819 17 19-12	Washer 17/32 x 1-3/16 x 12 Ga.

NOTE: All component dimensions given in U.S. inches
 1 inch = 25.4 mm

**TRACTOR - - MODEL NO. CTH126 (96051001400), PRODUCT NO. 960 51 00-14
SEAT ASSEMBLY 42**

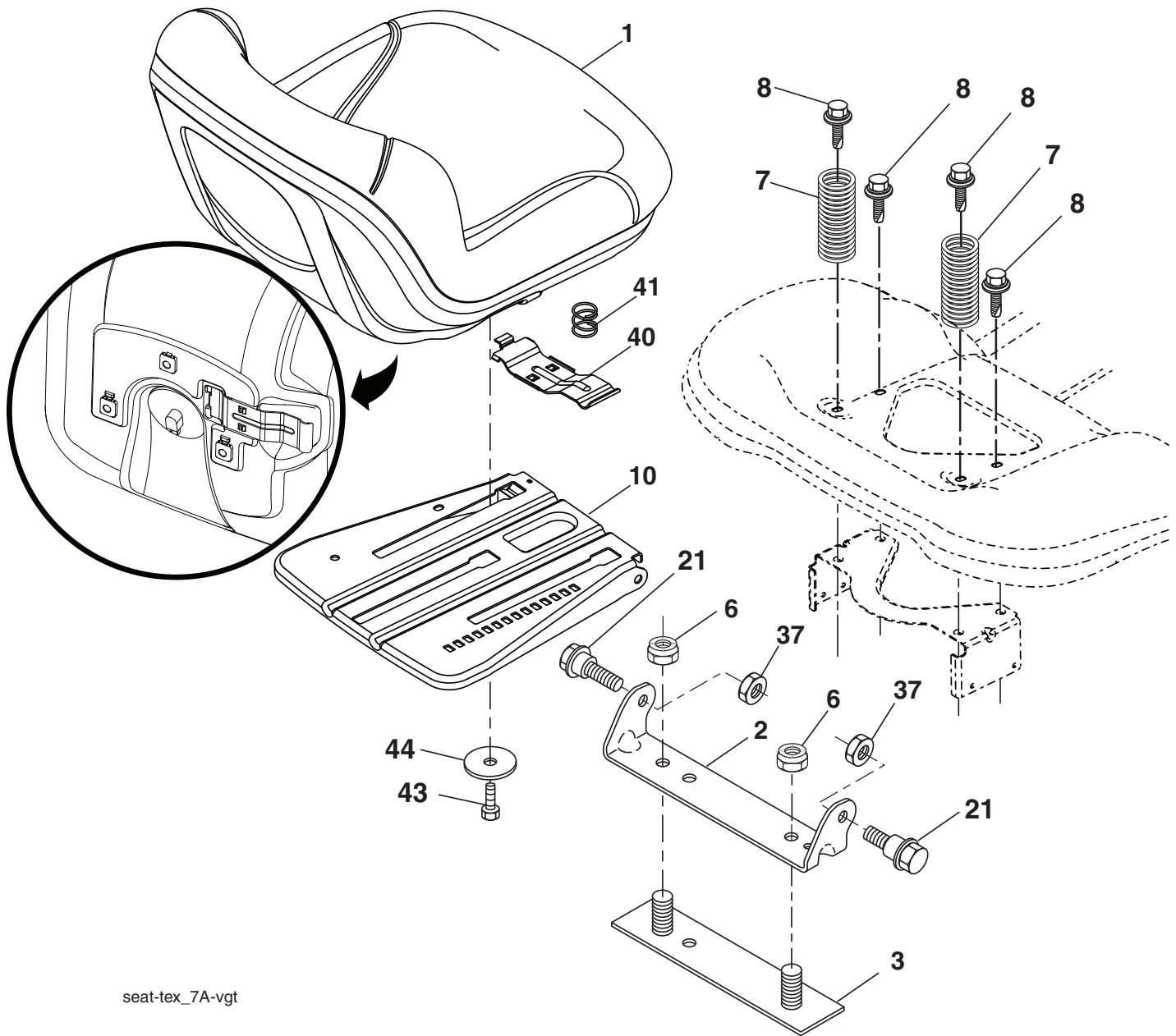

seat-tex_7A-vgt

KEY NO.	PART NO.	DESCRIPTION
1	532 43 98-19	Seat
2	532 18 01-66	Bracket Pivot Fender
3	532 14 06-75	Strap, Asm Fender
6	873 80 06-00	Nut, Lock w/Ins. 3/8-16 unc
7	532 12 41-81	Spring, Seat Cprsn
8	532 17 18-77	Bolt 5/16-18 unc x 3/4 w/Sems
10	532 19 69-77	Pan, Seat
21	532 17 18-52	Bolt, Shoulder 5/16-18

KEY NO.	PART NO.	DESCRIPTION
37	873 80 05-00	Nut, Lock 5/16-18 unc
40	532 19 76-61	Handle Slide Seat
41	532 19 82-00	Spring Latch Seat
43	874 76 06-12	Bolt 3/8-16 x 3/4
44	819 13 38-12	Washer 13/32 x 2-3/8 x 12 Ga.

NOTE: All component dimensions given in U.S. inches
1 inch = 25.4 mm

TRACTOR - - MODEL NO. CTH126 (96051001400), PRODUCT NO. 960 51 00-14
BAGGER 46

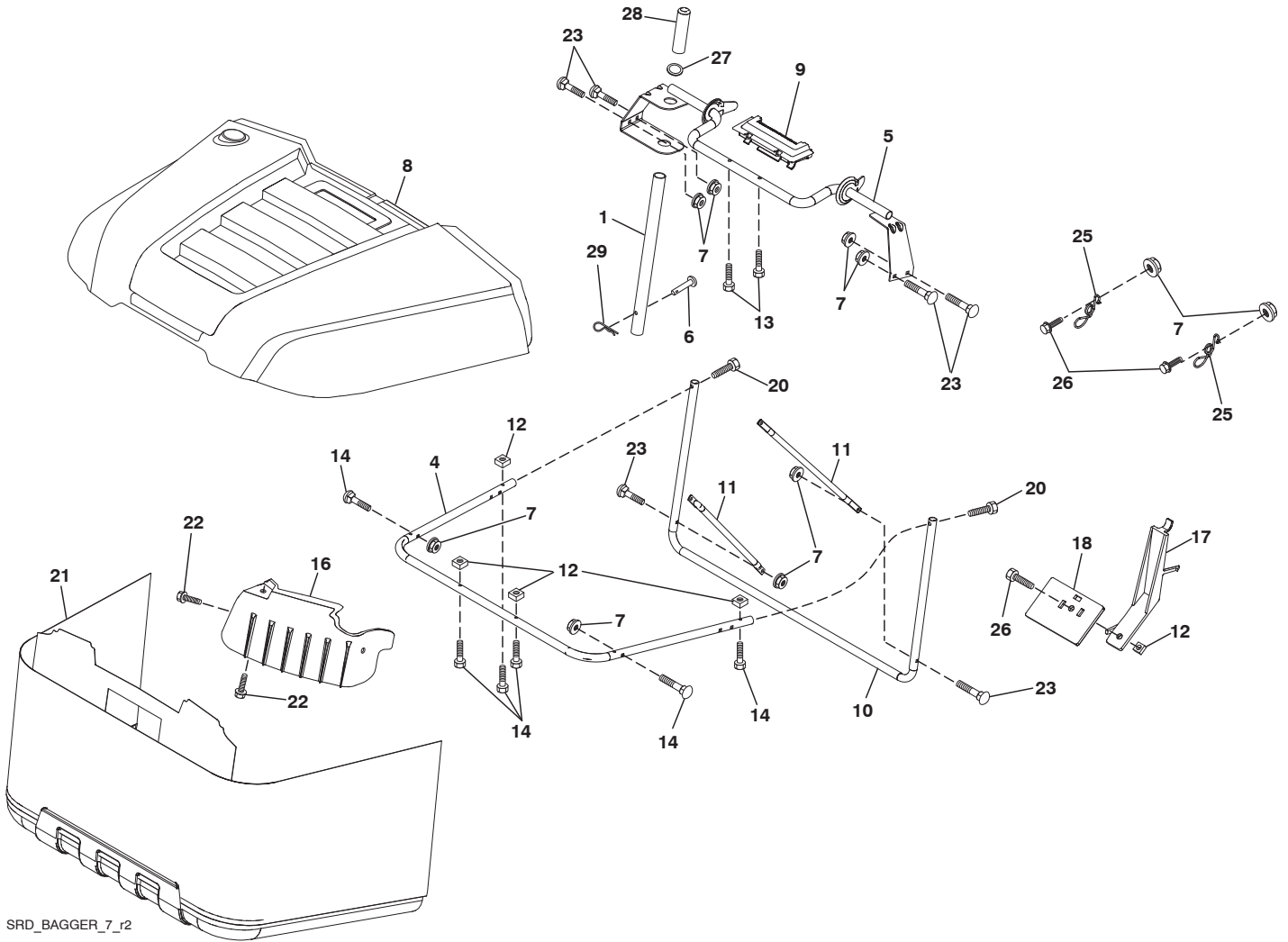

SRD_BAGGER_7_r2

**TRACTOR - - MODEL NO. CTH126 (96051001400), PRODUCT NO. 960 51 00-14
BAGGER 46**

KEY NO.	PART NO.	DESCRIPTION
1	532 42 86-10	Tube Handle Bagger SRD
4	532 43 96-12	Frame Asm Bagger Top
5	532 41 76-32	Frame Asm Top Bagger SRD
6	532 12 68-75	Drilled Rivit
7	873 90 04-00	Nut Hex Flange 1/4-20 unc
8	532 43 51-65	Bagger Top
9	532 41 76-29	Insert Handle Bagger
10	532 41 71-90	Frame Front
11	532 41 71-88	Tubing Brace Bagger
12	532 42 17-93	Nut Square 1/4
13	532 42 17-80	Screw 1/4 x 1.150 HXWSH
14	532 42 18-00	Bolt Shoulder HX WSH 1/4 x 1.150
16	532 42 15-66	Deflector Bagger
17	532 42 17-49	Lever Bagger Full
18	532 42 17-50	Paddle Bagger Full
20	585 36 88-01	Screw Hex Cap 1/4-20 x 1.375
21	532 42 99-81	Bag Asm SRD
22	532 14 24-32	Screw Hex WSH Hi-Lo 1/4 - 1/2 unc
23	872 04 04-10	Bolt Carr 1/4-20 unc x 1-1/4
25	532 42 16-14	Spring Latch Bagger
26	817 49 04-12	Screw Hex Thdrol 1/4-20 x 3/4
27	532 42 12-62	Grommet, Rubber SRD
28	532 16 57-87	Grip Handle Black
29	532 19 42-08	Pin Cotter 5/16 Bow Tie Lock

NOTE: All component dimensions given in U.S. inches
1 inch = 25.4 mm

