



WMH TOOL GROUP

Owner's Manual

Cold Saw

Models: CK350-2, CK350-2SX, CK350-4, CK350-4SX

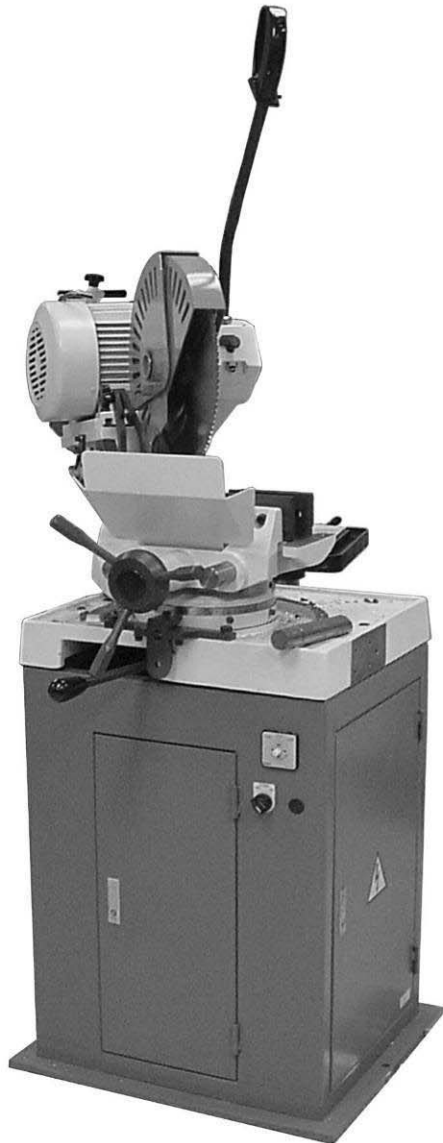

CK350



CK350-SX

WMH TOOL GROUP
2420 Vantage Drive
Elgin, Illinois 60124
Ph.: 800-274-6848
www.wmhtoolgroup.com

Part No. M-CK350-2
Revision B 02/07
Copyright © WMH Tool Group

CK350-SX Stand Assembly

Index No.	Part No.	Description	Size	Qty
1	FK350SX-601	Cabinet Stand		1
2	FK350SX-602	Foot Switch (Optional)		1
3	FK350-603	Cam Switch		1
4	FK350-604	Magnetic Switch		1
5	FK350SX-605	Overload Relay		1
7	FK350SX-607	Control Box Bracket		1
8	FK350SX-608	Control Box		1
9	FK350-609	Cable Lock		6
10	FK350-610	Rear Cover		1
11	TS-1503021	Socket Head Cap Screw	M6x10	4
12	FK350-612	Tapered Plug	PT1/4	1
13	FK350-613	Coolant Gauge		1
14	TS-1502051	Socket Head Cap Screw	M5x20	2
15	FK350SX-615	Lighted Push Button Switch		1
16	FK350SX-616	Lighted Push Button Switch		1
17	FK350SX-617	Emergency Switch		1
18	FK350SX-618	Selector Switch		2
19	FK350SX-619	Selector Switch		1
20	FK350SX-620	Flow Control Valve		1
21	TS-1504041	Socket Head Cap Screw	M8x20	2
22	TS-1551061	Lock Washer	M8	2
23	FK350SX-623	Flexible Connector		2
24	FK350SX-624	Transformer		1
25	FK350SX-625	Circuit Breaker		1
26	FK350SX-626	Fuse	5A, 30mm	2
27	FK350SX-627	Fuse Holder		1
28	FK350SX-628	Relay		5
29	FK350SX-629	Relay Socket		5
30	FK350SX-630	Relay		1
31	FK350SX-631	Relay Socket		1
32	FK350SX-632	Timer Relay		2
33	FK350SX-633	Terminal Block		30
34	FK350SX-634	Air Unit		1
35	FK350SX-635	Elbow Push Fitting	PT3/8	4
36	FK350SX-636	Elbow Push Fitting	PT1/4	1
37	FK350SX-637	Elbow Push Fitting	PT1/8	1
38	FK350SX-638	Nipple Push Fitting	PT3/8	4
39	FK350SX-639	Nipple	PT3/8	2
40	FK350SX-640	Reducer	PT3/8x1/4	1
41	FK350SX-641	T-Union	PT3/8	2
42	FK350SX-642	Solenoid Valve		1
43	FK350SX-643	Solenoid Valve		1
44	FK350SX-644	Socket Head Cap Screw	M4x60	3
45	TS-1550021	Flat Washer	M4	3
46	FK350SX-646	Silencer	PT3/8	4
47	FK350SX-647	Pipe		1
48	FK350SX-648	Ball Valve		1
49	FK350SX-649	Quick Coupler		1
50	FK350SX-650	Pressure Gauge		1

CK350-SX Stand Assembly

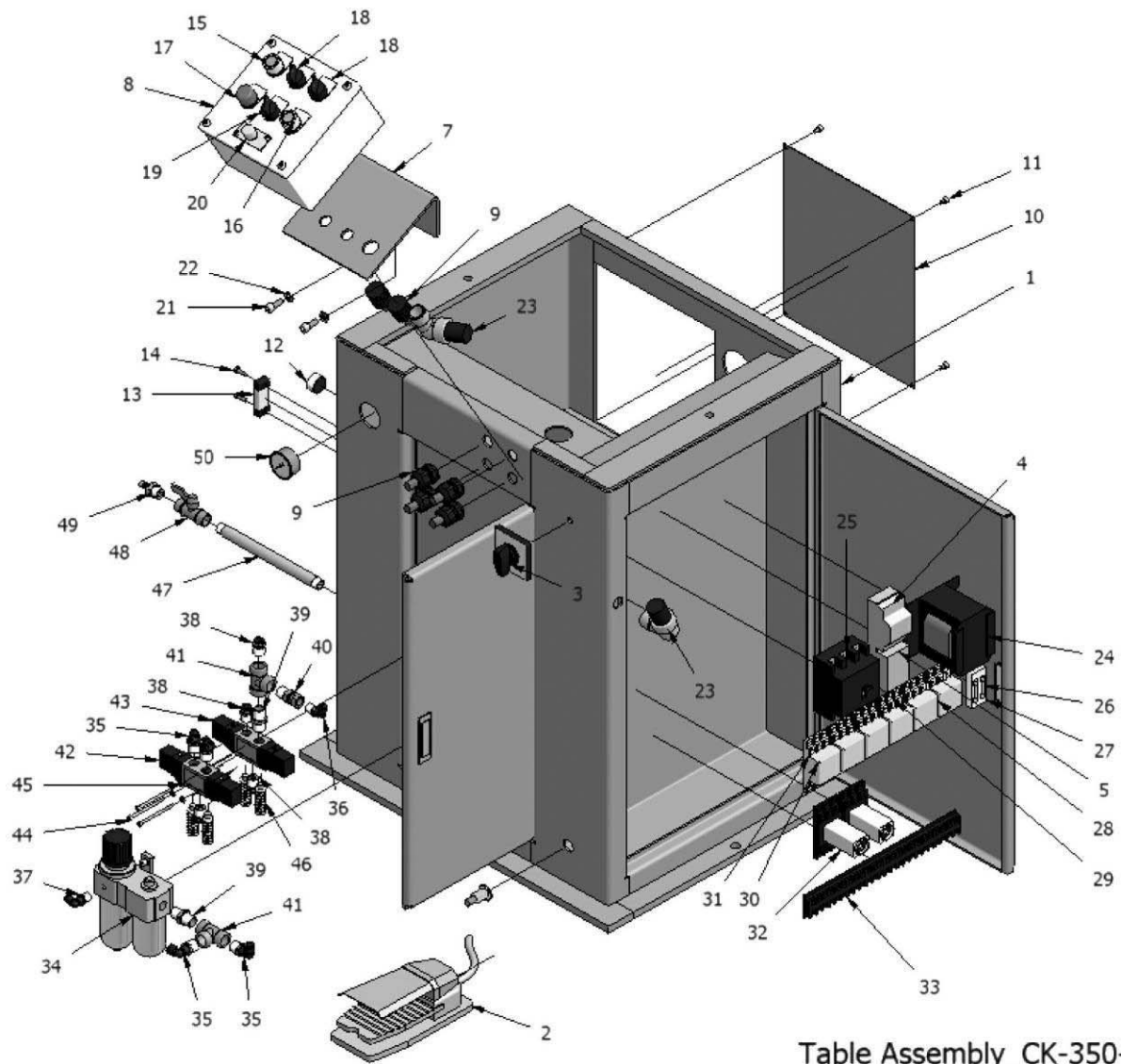
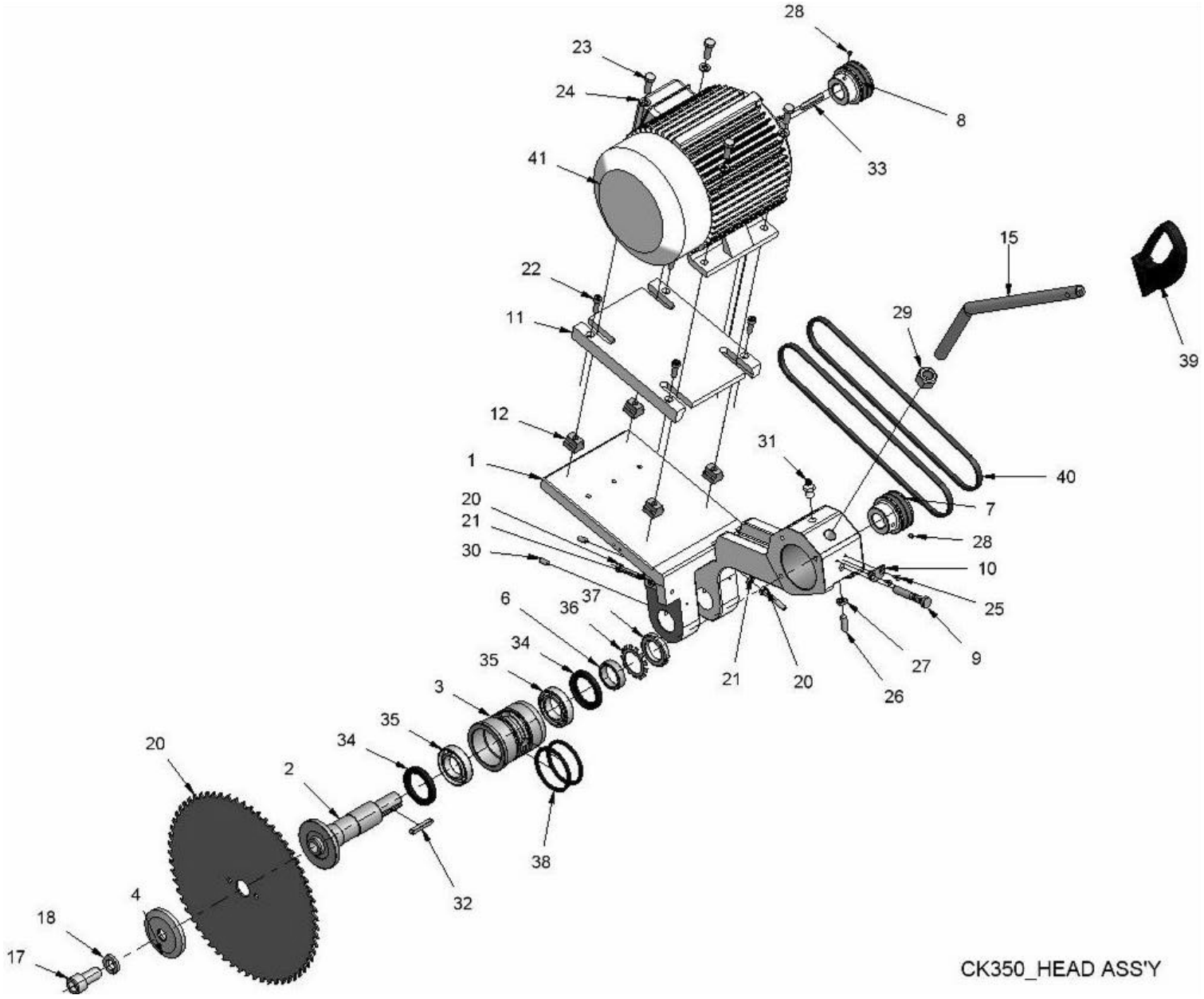

Table Assembly_CK-350-2SX

CK350 and CK350-SX Head Assembly

Index No.	Part No.	Description	Size	Qty
1	CK350-201	Head Body		1
2	CK350-202	Spindle		1
3	CK350-203	Spindle Housing		1
4	CK350-204	Blade Flange		1
6	CK350-206	Collar		1
7	CK350-207	Spindle pulley		1
8	CK350-208	Motor Pulley		1
9	CK350-209	Blade Lock		1
10	CK350-210	Blade Lock Guide		1
11	CK350-211	Motor Base		1
12	CK350-212	T-Nut		4
15	FK350-218	Handle (CK350 only)		1
17	CK350-217	Socket Head Cap Screw L.H. Thread	M20x40 LH	1
18	TS-2361201	Lock Washer	M20	1
19		Saw Blade		1
20	TS-1490091	Hex Cap Screw	M8x50	2
21	TS-1540061	Hex Nut	M8	2
23	TS-1491041	Hex Cap Screw	M10x30	4
24	TS-2361101	Lock Washer	M10	4
25	TS-1513011	Flat Head Socket Screw	M5x10	2
26	CK350-226	Ball Plunger		1
27	TS-1540071	Hex Nut	M10	1
28	TS-2276081	Set Screw	M6x8	2
29	TS-154012	Hex Nut	M20	1
30	TS-1504041	Socket Head Cap Screw	M8x20	2
31	CK350-231	Grease Fitting	PT1/4	1
32	CK350-232	Flat Key	7x7x50mm	1
33	CK350-233	Flat Key	8x7x50mm	1
34	CK350-234	Oil Seal		2
35	CK350-235	Angular Ball Bearing	#7008	2
36	CK350-236	Bearing Washer		1
37	CK350-237	Bearing Nut		1
38	CK350-238	O-Ring	P71	2
39	FK350-219	Handle Switch (CK350 only)		1
39	CK350SX-239	Plug (CK350-SX only)		1
40	CK350-240	V-Belt 3V-370		2
41	CK350-241	Motor 220V		1
	CK350-241-4	Motor 440V		1



CK350_HEAD ASS'Y

CK350-SX Base Assembly

Index No.	Part No.	Description	Size	Qty
1	FK350-101	Base		1
2	FK350-102	Hinge Body		1
3	FK350-103	Locking Mount		1
4	FK350-104	Release Handle		1
5	FK350-105	Pin		1
6	FK350-106	Coil Spring		1
7	FK350-107	Scale		1
8	FK350-108	Pivot Shaft		1
11	FK350-112	Chip Screen		1
15	TS-1504101	Socket Head Cap Screw	M8x50	2
22	TS-223A911	Socket Head Cap Screw	M12x100	2
23	TS-1504021	Socket Head Cap Screw	M8x12	2
24	TS-1491041	Hex Cap Screw	M10x30	2
25	TS-2361101	Lock Washer	M10	2
26	TS-1490041	Hex Cap Screw	M8x25	1
27	FK350-122	Pipe		1
28	FK350-123	Pin	10mm Dia. x 22	3
29	FK350-124	Grease Fitting	PT 1/8	2

CK350-SX Base Assembly

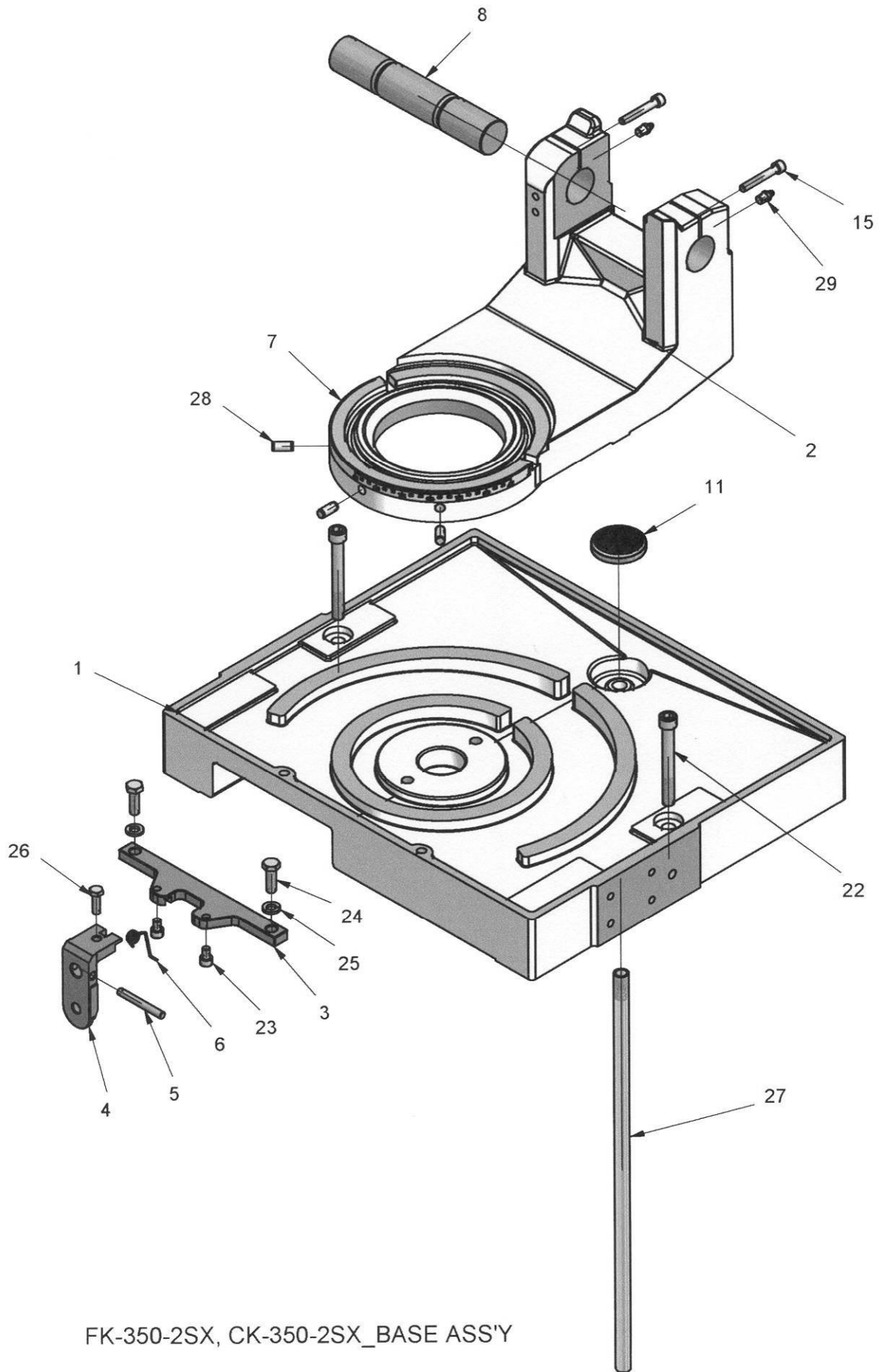

FK-350-2SX, CK-350-2SX_BASE ASS'Y

CK350-SX Power Vise Assembly

Index No.	Part No.	Description	Size	Qty
1	FK350-301	Base		1
2	FK350-302	Vise Jaw		1
3	FK350-303	Tip		1
4	FK350SX-304	Vise Screw, Semi-Auto		1
5	CK350-305	Jaw Insert A (Al)		2
6	CK350-306	Jaw Insert B (Al)		2
7	FK350-307	Guide Rod		2
8	FK350-308	Handle Hub		1
9	FK350-309	Handle		3
10	FK350-310	Filling Block		1
11	FK350-311	Locking Nut		1
12	FK350-312	Cap		1
13	FK350-313	Setting Screw		1
14	FK350-314	Hex Nut	M20x1.5P	1
15	FK350-315	Cover		1
16	FK350-316	Tension Handle		1
17	FK350-317	Tension Nut		1
18	FK350-318	Pressure Plate		1
19	FK350-319	Scale Centering		1
20	FK350SX-320	Front Vise Jaw		1
21	FK350SX-321	Cylinder Cover		1
22	FK350SX-322	Piston		1
23	FK350SX-323	Vise Cylinder		1
24	FK350-320	Pin	10mm Dia. x 30	2
25	FK350-321	Retainer		2
26	TS-1505051	Socket Head Cap Screw	M10x35	4
27	TS-1540071	Hex Nut	M10	4
28	TS-209605	Roll Pin	M8x40	1
29	TS-1502031	Socket Head Cap Screw	M5x12	2
30	TS-1550031	Flat Washer	M5	2
31	TS-1490091	Hex Cap Screw	M8x50	3
32	TS-1540061	Hex Nut	M8	3
33	TS-1505041	Socket Head Cap Screw	M10x30	2
34	TS-1505011	Socket Head Cap Screw	M10x16	2
35	FK350-331	Rivet	2mm Dia. x 4	2
36	FK350SX-336	O-Ring	P130	2
37	FK350SX-337	O-Ring	P35	2
38	FK350SX-338	Spring Pin	6mm Dia. x 25	1
39	TS-1502031	Socket Head Cap Screw	5x12	6
40	FK350SX-340	Dust Seal		1
41	TS-2236801	Socket Head Cap Screw	M6x80	2
42	FK350SX-342	Elbow Push Fitting	PT1/4	1
43	FK350SX-343	Speed Control	PT1/4	1
44	FK350SX-344	Elbow	PT1/4	1

CK350-SX Power Vise Assembly

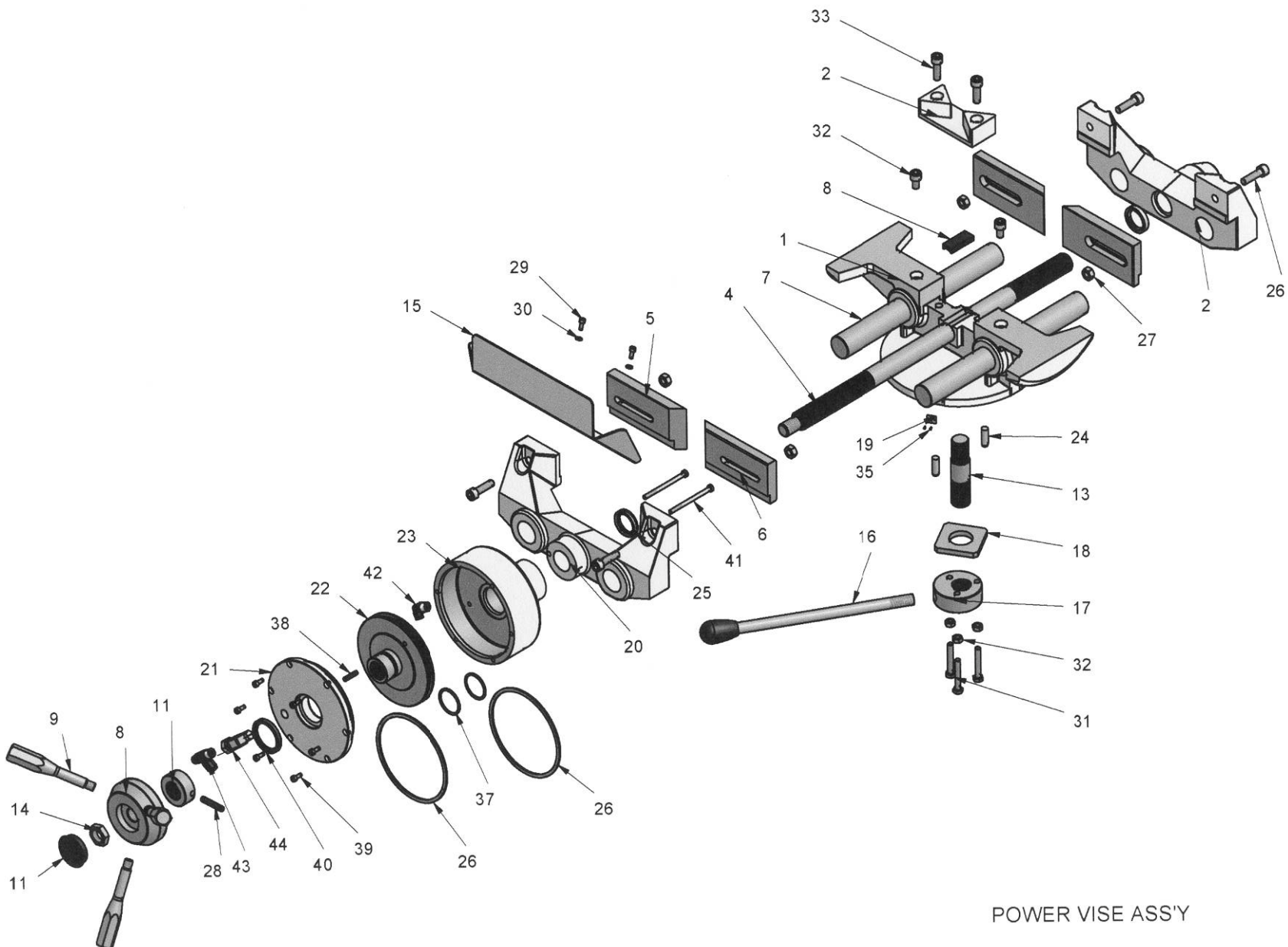

POWER VISE ASS'Y

CK350 & CK350-SX Guard Assembly

Index No.	Part No.	Description	Size	Qty
1	CK350-401	Guard A		1
2	CK350-402	Guard B		1
3	CK350-403	Chute		1
4	CK350-404	Belt Guard		1
5	CK350-405	Plate		2
6	CK350-406	Rubber Guide		2
7	CK350-407	Nylon Spacer A		1
8	CK350-408	Nylon Spacer B		1
9	CK350-409	Link A		1
10	CK350-410	Link B		1
11	CK350-411	Link Bracket		1
12	FK350-410	Link Ring		1
13	TS-1504081	Socket Head Cap Screw	M8x40	2
14	TS-1504031	Socket Head Cap Screw	M8x16	1
15	TS-1550061	Flat Washer	M8	1
16	TS-1504041	Socket Head Cap Screw	M8x20	3
17	TS-1551061	Lock Washer	M8	3
18	TS-2284082	Screw	M4x8	8
19	TS-1501031	Socket Head Cap Screw	M4x10	4
20	TS-1502021	Socket Head Cap Screw	M5x10	4
21	TS-1551031	Lock Washer	M5	3
22	CK350-422	Hose Joint		1
23	CK350-423	Bushing		1
24	CK350-424	Bushing		1
25	FK350-421	Snap Ring	S10	1
26	CK350-426	Snap Ring	S45	1
27	FK350-423	Knob	M8x30	1

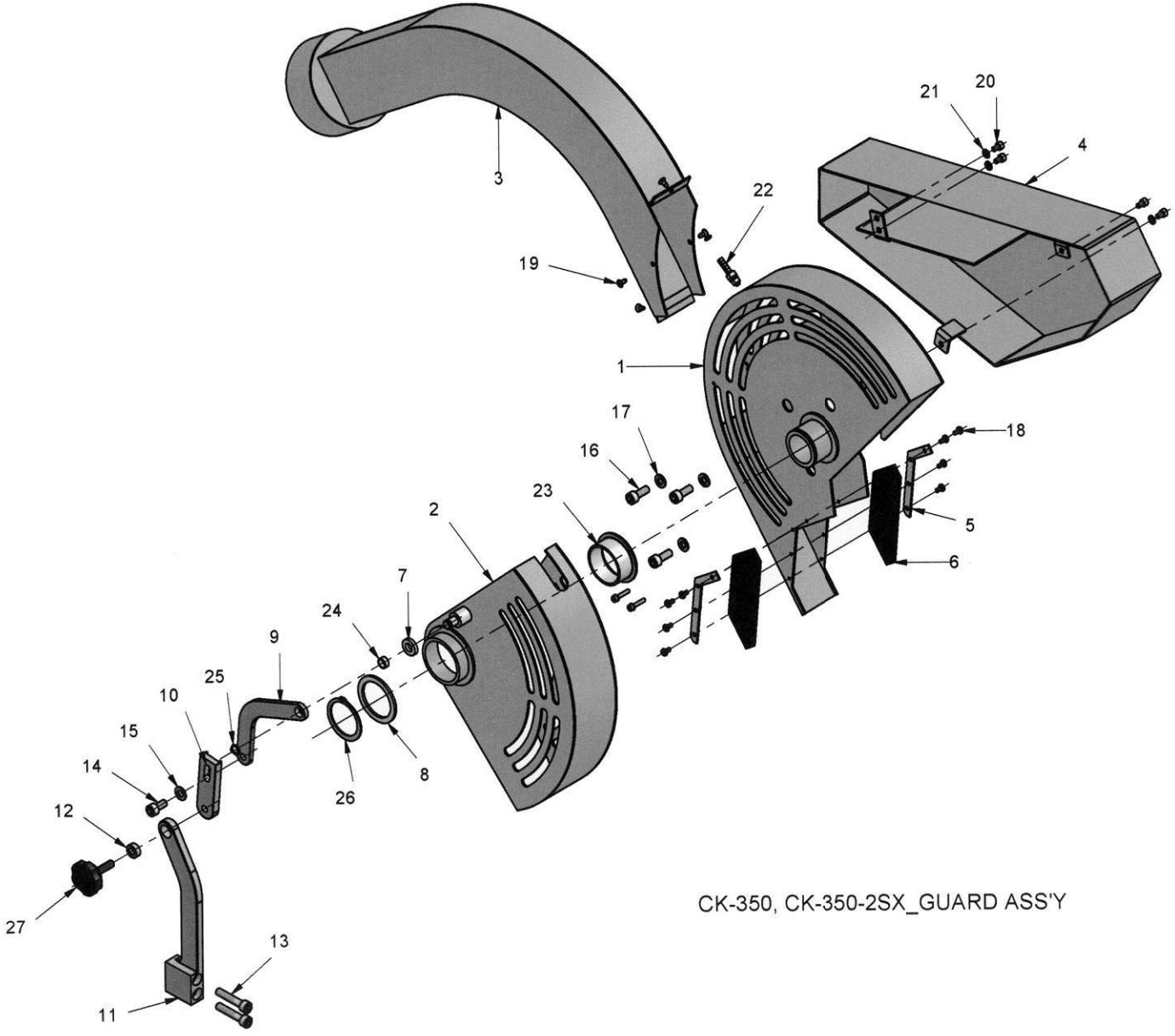

CK-350, CK-350-2SX_GUARD ASS'Y

CK350-SX Power Feed and Coolant Assembly

Index No.	Part No.	Description	Size	Qty
1	CK350SX-701	Cylinder Bracket A	1	1
2	FK350SX-702	Spring Bracket B	1	1
3	FK350SX-703	Converter Bracket	1	1
4	FK350SX-704	Cylinder Bracket	1	1
5	FK350SX-705	Hinge Bolt	2	2
6	FK350SX-706	Limit Rod	1	1
7	FK350SX-707	Limit Dog	2	2
8	FK350SX-708	Knuckle Pin	1	1
9	CK350SX-709	Thread Extension	1	1
10	CK350SX-710	Cylinder	1	1
11	FK350SX-712	Converter	1	1
12	FK350SX-713	Limit Switch	2	2
13	FK350SX-714	Elbow Push Fitting	PT3/8	3
14	FK350SX-715	Compression Fitting	1	1
15	TS-1504061	Socket Head Cap Screw	M8x30	4
16	TS-1551061	Lock Washer	M8	4
17	TS-1491041	Hex Cap Screw	M10x30	4
18	TS-2361101	Lock Washer	M10	4
19	TS-1506111	Socket Head Cap Screw	M12x70	4
20	TS-1503051	Socket Head Cap Screw	M6x20	3
21	FK350SX-722	Handle	2	2
22	FK350SX-723	Snap Ring	S12	1
23	CK350-701	Coolant Block	1	1
24	CK350-702	Coolant Nipple	1	1
25	CK350-703	Coolant Nozzle	1	1
26	CK350-708	Throttle Valve	1	1
27	CK350-709	Elbow Push Fit	PT1/8, 4mm Dia	2
28	CK350SX-728	Joint Push Fit	PT1/8, 4mm Dia	1
29	CK350-712	Miniature Coupling	M5	2
30	TS-1501061	Socket Head Cap Screw	M4x20	2
31	TS-1490051	Hex Cap Screw	M8x30	1
32	TS-1540061	Hex Nut	M8	1
33	CK350-722	O-Ring	P5	1
34	CK350SX-133	Spring Bracket A		1
35	CK350-110	Spring Bracket B		1
36	CK350-112	Return Spring		1
37	CK350-113	Spring Holder A		1
38	CK350-114	Spring Holder B		1
39	TS-1504051	Socket Head Cap Screw	M8x25	2
40	TS-1551061	Lock Washer	M8	2
41	TS-1504031	Socket Head Cap Screw	M8x16	2
42	TS-1550061	Flat Washer	M8	2
43	TS-1505031	Socket Head Cap Screw	M10x25	2
44	TS-1551071	Lock Washer	M10	2

CK350-SX Power Feed and Coolant Assembly

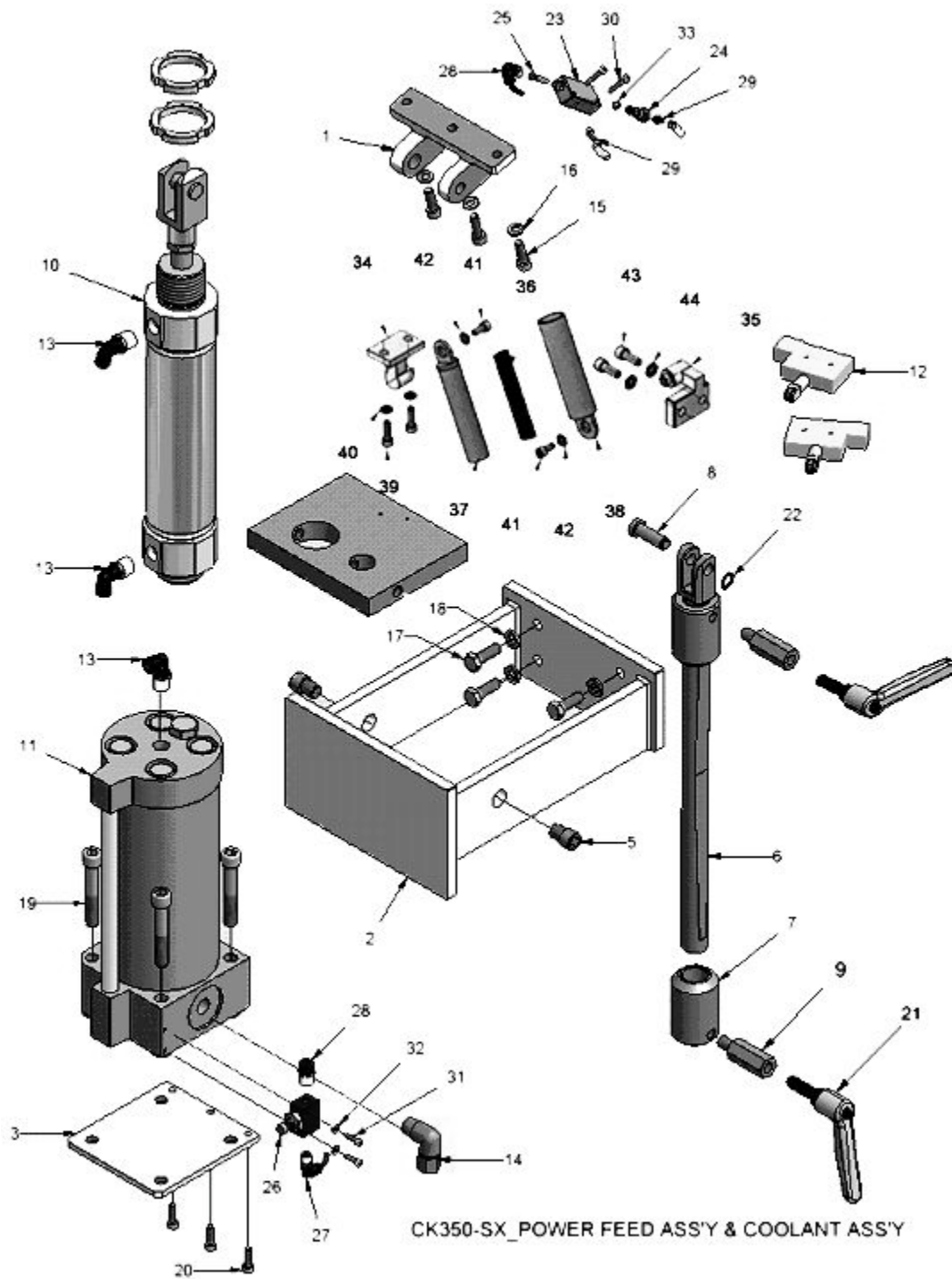

In-Feed Table

Index No.	Part No.	Description	Size	Qty
1	FK350-701	Bracket		1
2	FK350-702	Stand		1
3	FK350-703	Leveling Foot		2
4	TS-154010	Hex Nut M16		2
5	FK350-705	Angle Rail		2
6	FK350-706	Base A		1
7	FK350-707	Base B		1
8	TS-1491041	Hex Cap Screw	M10x30	8
9	TS-1491061	Hex Cap Screw	M10x40	2
10	TS-1491121	Hex Cap Screw	M10x70	2
11	TS-2361101	Lock Washer	M10	12
12	TS-1540071	Hex Nut	M10	16
13	FK350-713	Roller		6
14	FK350-714	Roller Bracket		12
15	TS-1502021	Socket Head Cap Screw	M5x10	12
16	FK350-716	Cover A		2
17	FK350-717	Cover B		5
18	TS-1533032	Pan Head Screw	M5x10	7

In & Out Supply Track Assembly

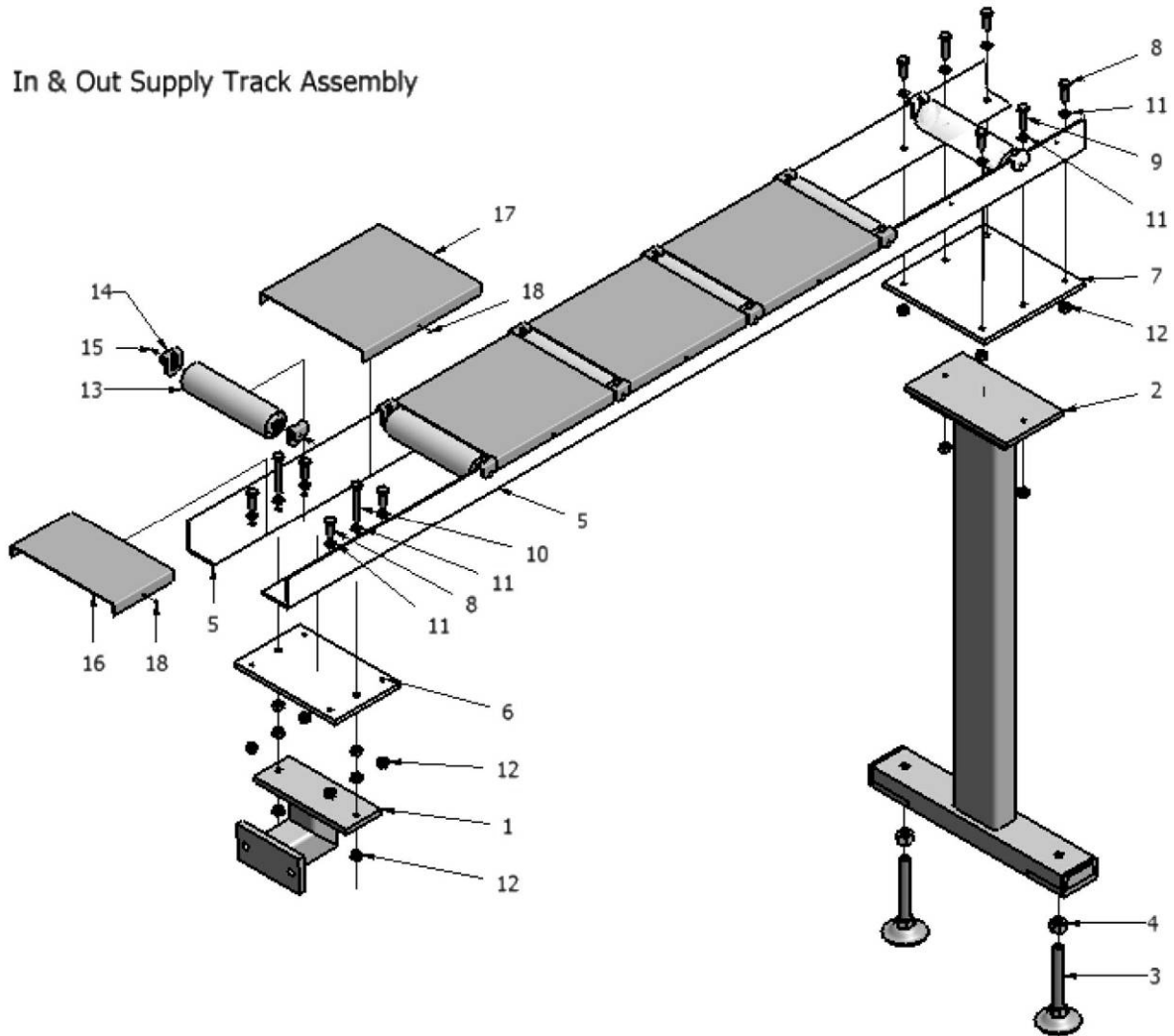

Out-Feed Table

Index No.	Part No.	Description	Size	Qty
1	FK350-801	Guide Block		EA
2	FK350-802	Guide Rail		EA
3	TS-1502051	Socket Head Cap Screw	M5x20	EA
4	FK350-804	Stopper Base		EA
5	TS-1502051	Socket Head Cap Screw	M5x20	EA
6	FK350-806	Connecting Plate		EA
7	TS-1502071	Socket Head Cap Screw	M5x30	EA
8	FK350-808	Lock Block A		EA
9	FK350-809	Lock Block B		EA
10	FK350-818	Spring		EA
11	FK350-811	Stopper		EA
12	TS-1503051	Socket Head Cap Screw	M6x20	EA
13	FK350-813	Stopper Pad		EA
14	TS-1502041	Socket Head Cap Screw	M5x16	EA
15	FK350-815	Scale Indicator		EA
16	FK350-816	Rivet		EA
17	FK350-817	Inch Scale		EA
18	FK350-810	Handle		EA

Out Line Track Scale Stopper Assembly

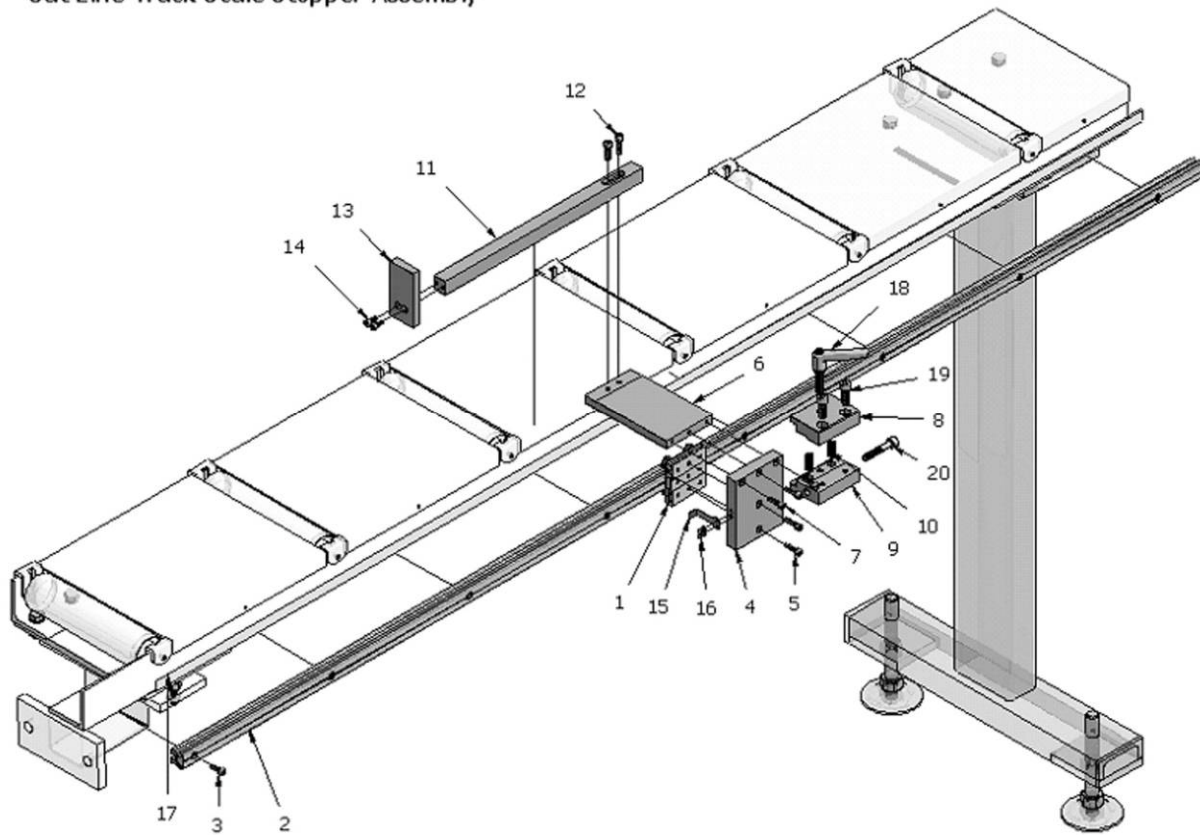

Stock Stop Assembly

Index No.	Part No.	Description	Size	Qty
1	FK350-501	Block		1
2	FK350-502	Shaft		1
3	FK350-503	Stop Rod		1
4	FK350-504	Scale (Inch)		1
6	FK350-506	Handle	M8x30	2
7	FK350-505	Rivet		2

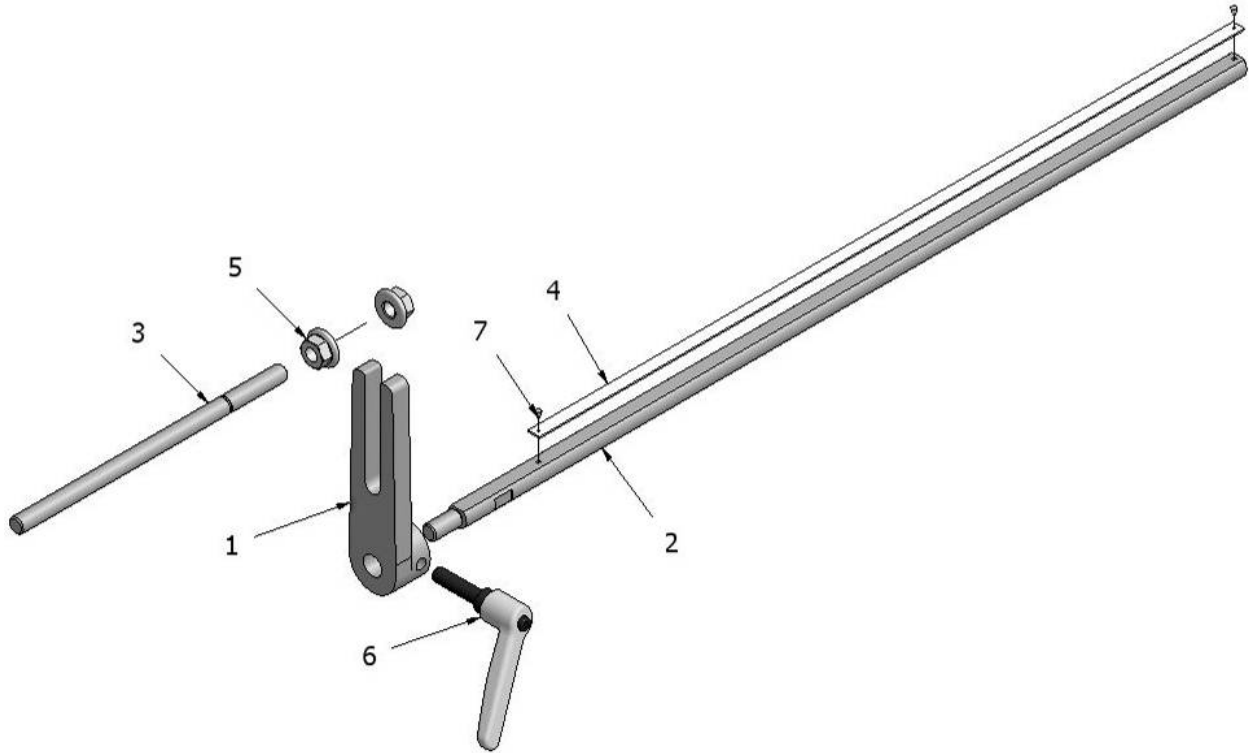



WMH Tool Group
2420 Vantage Drive
Elgin, Illinois 60124
Phone: 800-274-6848
www.wmhtoolgroup.com