

## ELECTRIC TOOL PARTS LIST

■ COMPOUND SAW  
Model C 12FCH

2004 • 10 • 1

(E1)

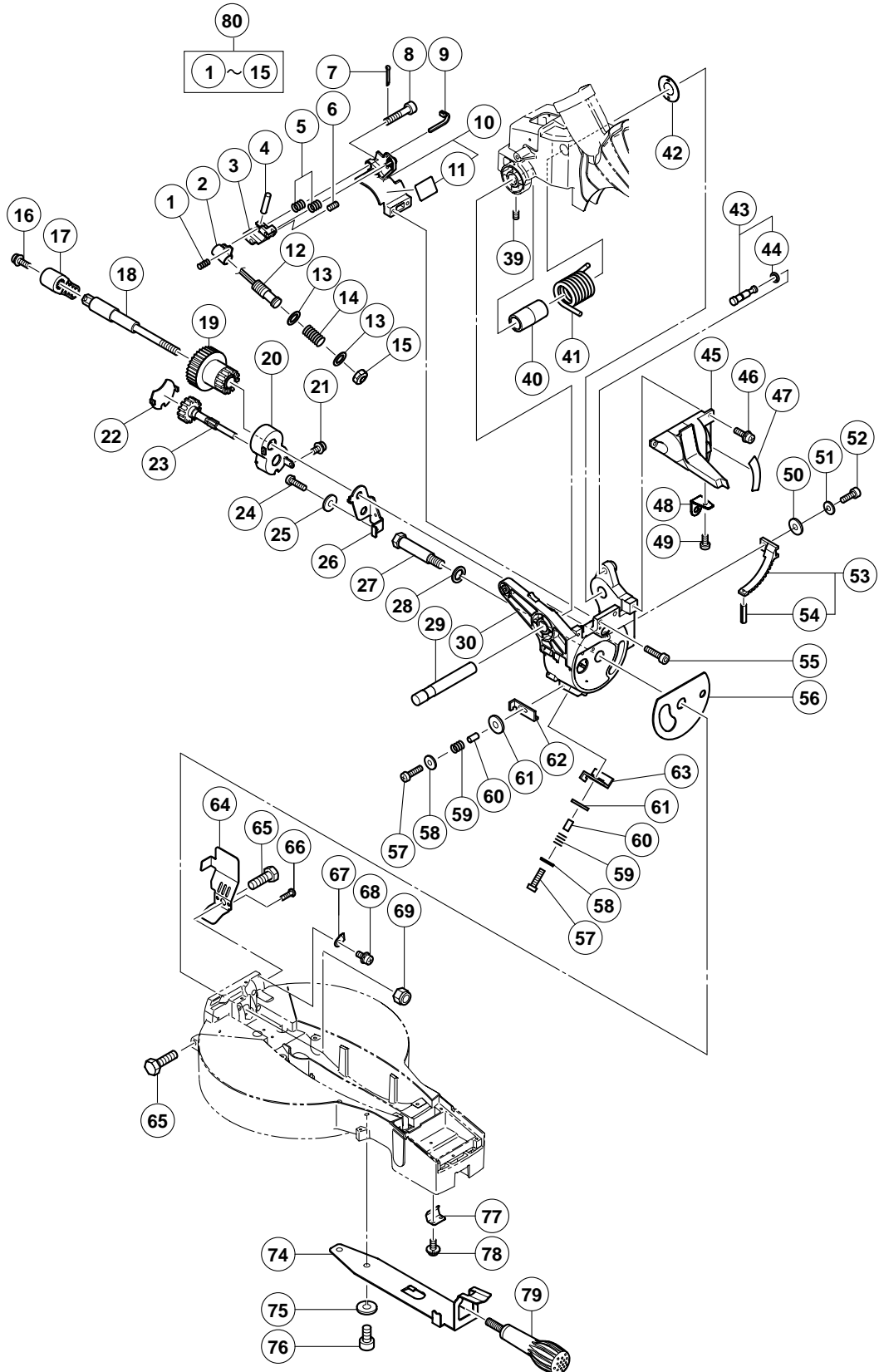

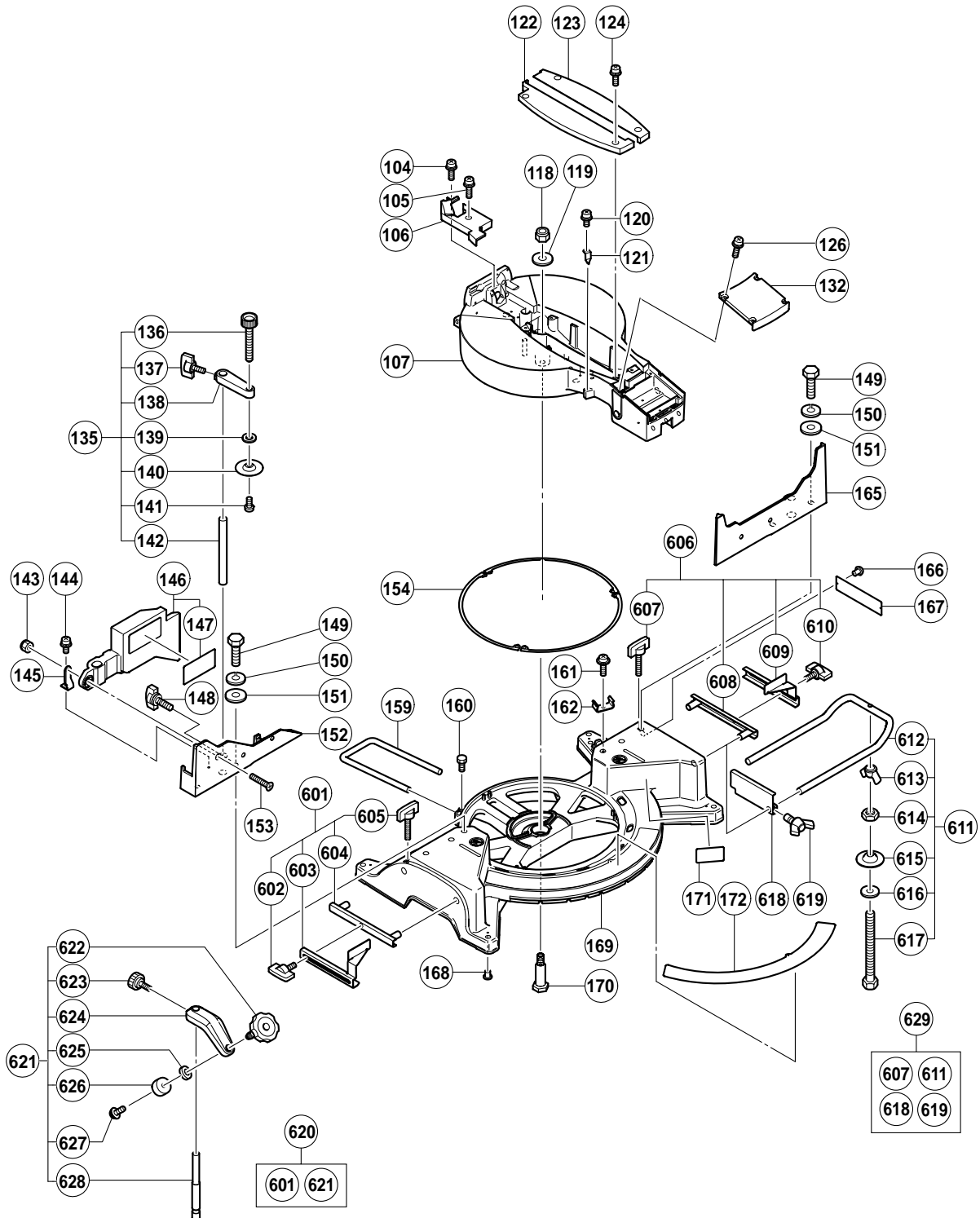

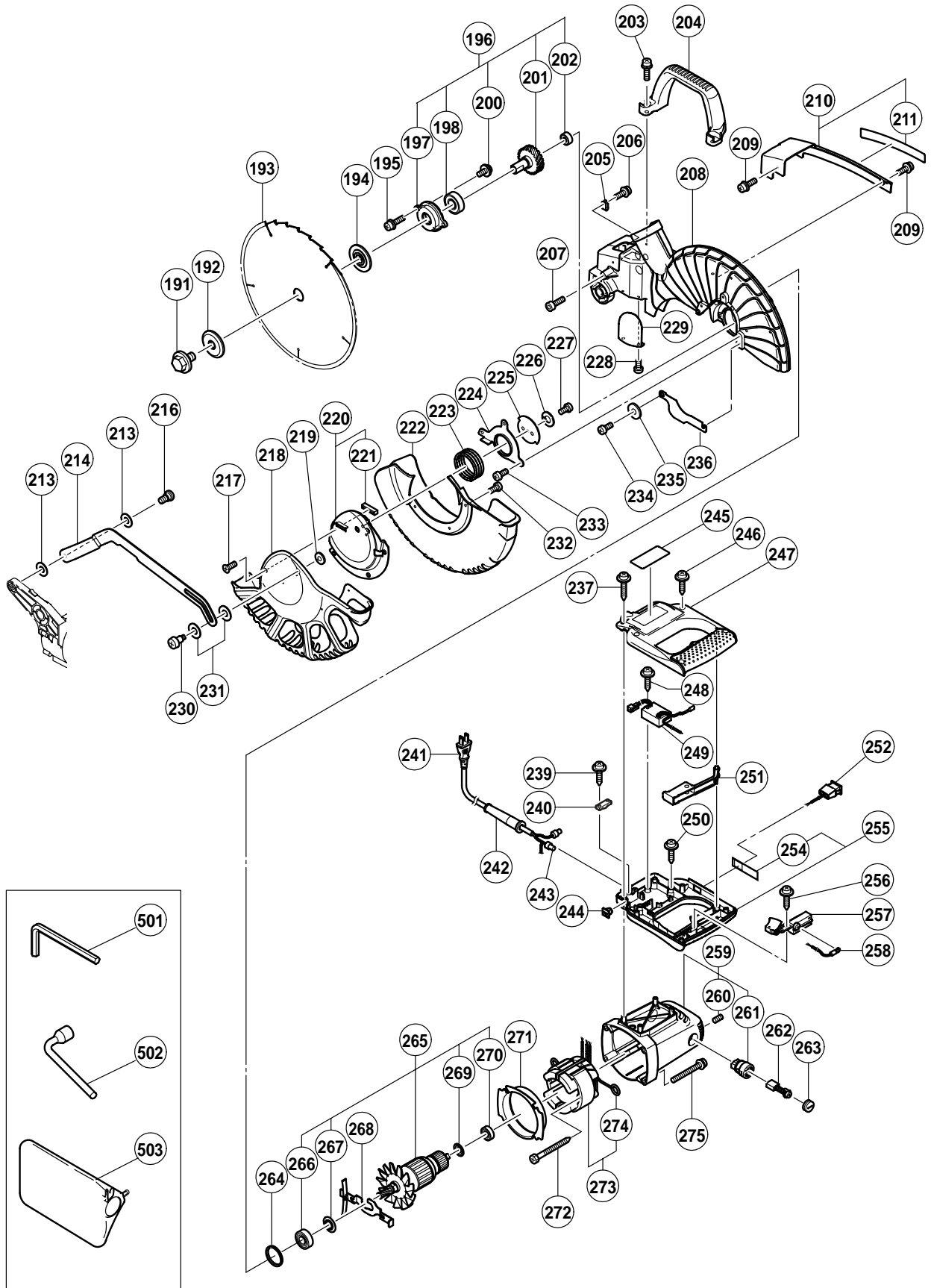

**PARTS**

C 12FCH

ITEM NO.	CODE NO.	DESCRIPTION	NO. USED	REMARKS
1	323-141	SPRING (B)	1	
2	323-137	LASER HOLDER (A)	1	
3	323-138	LASER HOLDER (B)	1	
4	949-900	ROLL PIN D3X14 (10 PCS.)	1	
5	323-142	SPRING (C)	2	
6	962-782	HEX. SOCKET SET SCREW M5X6	1	
7	949-531	SPLIT PIN D2X12 (10 PCS.)	1	
8	323-144	SPECIAL BOLT M5	1	
9	975-144	CABLE TIE	1	
10	323-139	LASER BASE ASS'Y	1	INCLUD. 11
11		CAUTION LABEL (A)	1	
12	323-647	LASER MODULE	1	
13	323-143	WASHER	2	
14	323-140	SPRING (A)	1	
15	323-136	LASER COVER	1	
16	323-208	MACHINE SCREW (W/WASHERS) M6X20 (BLACK)	1	
17	322-935	CLAMP LEVER	1	
18	323-665	BOLT (LEFT HAND) M10	1	
19	323-666	KNOB (A)	1	
20	323-597	GEAR BOX (C)	1	
21	304-043	MACHINE SCREW (W/WASHERS) M4X10 (BLACK)	1	
22	323-598	GEAR BOX (C) COVER	1	
23	323-599	PINION	1	
24	949-821	HEX. SOCKET HD. BOLT M5X16 (10 PCS.)	1	
25	949-454	SPRING WASHER M5 (10 PCS.)	1	
26	323-596	HINGE PLATE	1	
27	322-933	SHAFT (D)	1	
28	322-934	WASHER M16	1	
29	323-593	SHAFT (C)	1	
30	323-663	HINGE	1	
39	307-956	SEAL LOCK HEX. SOCKET SET SCREW M6X10	1	
40	323-594	SLEEVE	1	
41	323-595	SPRING (A)	1	
42	323-684	LINER (D)	1	
43	302-518	STOPPER PIN ASS'Y	1	INCLUD. 44
44	984-528	O-RING (P-6)	1	
45	323-719	DUST GUIDE ASS'Y	1	INCLUD. 47-49
46	990-541	MACHINE SCREW (W/WASHERS) M5X16	2	
47	323-697	SCALE (B)	1	
48	322-963	DUST GUIDE HOLDER	1	
49	949-214	MACHINE SCREW M4X6 (10 PCS.)	1	
50	949-431	BOLT WASHER M5 (10 PCS.)	1	
51	949-454	SPRING WASHER M5 (10 PCS.)	1	
52	949-821	HEX. SOCKET HD. BOLT M5X16 (10 PCS.)	1	
53	323-664	GEAR (C) ASS'Y	1	INCLUD. 54
54	949-900	ROLL PIN D3X14 (10 PCS.)	1	
55	949-660	HEX. SOCKET HD. BOLT M6X20 (10 PCS.)	2	
56	323-683	LINER (B)	1	
57	949-221	MACHINE SCREW M4X20 (10 PCS.)	2	
58	949-423	WASHER M4 (10 PCS.)	2	
59	323-142	SPRING (C)	2	

**PARTS**

C 12FCH

ITEM NO.	CODE NO.	DESCRIPTION	NO. USED	REMARKS
60	303-006	SPACER D4X10	2	
61	949-432	BOLT WASHER M6 (10 PCS.)	2	
62	323-662	BEVEL PLATE (B)	1	
63	323-661	BEVEL PLATE (A)	1	
64	323-659	COVER (A)	1	
65	303-409	NYLOCK BOLT M8X25	2	
66	935-196	MACHINE SCREW (W/WASHERS) M4X12 (BLACK)	2	
67	322-893	INDICATOR (B)	1	
68	304-043	MACHINE SCREW (W/WASHERS) M4X10 (BLACK)	1	
69	680-418	NYLON NUT M12	1	
74	323-627	SPRING PLATE	1	
75	949-457	SPRING WASHER M8 (10 PCS.)	2	
76	949-655	HEX. SOCKET HD. BOLT M8X16 (10 PCS.)	2	
77	323-609	SPACER (A)	1	
78	307-635	MACHINE SCREW (W/SP. WASHER) M4X10	2	
79	323-680	SIDE HANDLE	1	
80	323-646	LASER HOLDER ASS'Y	1	INCLUD. 1-10, 12-15
104	949-216	MACHINE SCREW M4X10 (10 PCS.)	1	
105	954-878	MACHINE SCREW (W/WASHERS) M4X16	1	
106	323-650	CORD COVER	1	
107	323-624	TURN TABLE	1	
118	975-348	NYLON NUT M8	1	
119	318-929	WASHER (F)	1	
120	304-043	MACHINE SCREW (W/WASHERS) M4X10 (BLACK)	1	
121	318-927	INDICATOR (A)	1	
122	323-648	TABLE INSERT (A)	1	
123	323-649	TABLE INSERT (B)	1	
124	990-541	MACHINE SCREW (W/WASHERS) M5X16	4	
126	993-539	MACHINE SCREW (W/WASHERS) M4X16	4	
132	323-693	MONITOR CASE (B)	1	
135	323-677	VICE ASS'Y	1	INCLUD. 136-142
136	323-678	KNOB BOLT	1	
137	301-806	WING BOLT M6X15	1	
138		SCREW HOLDER	1	
139	949-432	BOLT WASHER M6 (10 PCS.)	1	
140	302-532	VICE PLATE	1	
141	949-216	MACHINE SCREW M4X10 (10 PCS.)	1	
142	322-954	VICE SHAFT	1	
143	311-144	NYLON NUT M6	1	
144	304-043	MACHINE SCREW (W/WASHERS) M4X10 (BLACK)	1	
145	323-631	PLATE (C)	1	
146	323-630	SUB FENCE ASS'Y	1	INCLUD. 147
147		WARNING LABEL (H)	1	
148	301-806	WING BOLT M6X15	1	
149	949-678	BOLT M8X35 (10 PCS.)	4	
150	949-457	SPRING WASHER M8 (10 PCS.)	4	
151	949-433	BOLT WASHER M8 (10 PCS.)	4	
152	323-629	FENCE (B)	1	
153	323-685	FLAT HD. SCREW M6X30	1	
154	323-625	LINER (A)	3	
159	322-910	HOLDER	1	

**PARTS**

C 12FCH

ITEM NO.	CODE NO.	DESCRIPTION	NO. USED	REMARKS
160	949-610	BOLT M6X10 (10 PCS.)	1	
161	987-512	MACHINE SCREW (W/SP. WASHER) M5X16	1	
162	323-605	HOOK	1	
165	323-628	FENCE (A)	1	
166	949-510	RIVET D2.5X4.8 (10 PCS.)	2	
167		WARNING LABEL (A)	1	
168	323-606	BASE RUBBER	4	
169	323-696	BASE ASS'Y	1	INCLUD. 166-168, 171, 172
170	323-626	SHAFT (B)	1	
171		CAUTION LABEL (C)	1	
172	323-692	SCALE (A)	1	
191	988-101	BOLT (A) M10	1	
192	323-652	WASHER (B)	1	
193	323-522	TCT SAW BLADE 305MM-D25.4 HOLE-NT32	1	
194	323-651	WASHER (A)	1	
195	323-208	MACHINE SCREW (W/WASHERS) M6X20 (BLACK)	2	
196	323-639	SPINDLE ASS'Y	1	INCLUD. 197, 198, 200-202
197	323-641	BEARING HOLDER	1	
198	620-3VV	BALL BEARING 6203VVCMP2L	1	
200	304-043	MACHINE SCREW (W/WASHERS) M4X10 (BLACK)	2	
201	323-640	SPINDLE AND GEAR SET	1	
202	608-VVM	BALL BEARING 608VVC2PS2L	1	
203	323-208	MACHINE SCREW (W/WASHERS) M6X20 (BLACK)	2	
204	322-924	HANDLE	1	
205	980-523	NYLON CLIP	1	
206	935-196	MACHINE SCREW (W/WASHERS) M4X12 (BLACK)	1	
207	949-755	HEX. SOCKET HD. BOLT M6X16 (10 PCS.)	1	
208	323-638	GEAR CASE	1	
209	993-539	MACHINE SCREW (W/WASHERS) M4X16	2	
210	323-653	GEAR CASE COVER ASS'Y	1	INCLUD. 211
211	323-654	CAUTION LABEL (B)	1	FOR POSITION ADJUSTMENT OF LASER LINE
213	322-948	WASHER M7	2	
214	323-674	LINK	1	
216	322-950	SPECIAL SCREW M6	1	
217	318-363	FLAT HD. SCREW M4X10 (BLACK)	1	
218	323-698	PROTECTIVE COVER (B)	1	
219	949-454	SPRING WASHER M5 (10 PCS.)	1	
220	323-672	COVER PLATE (B) ASS'Y	1	INCLUD. 221
221	323-673	CUSHION	1	
222	323-667	PROTECTIVE COVER (A)	1	
223	323-671	RETURN SPRING	1	
224	323-669	COVER PLATE (A)	1	
225	323-670	COVER WASHER	1	
226	949-454	SPRING WASHER M5 (10 PCS.)	1	
227	949-236	MACHINE SCREW M5X10 (10 PCS.)	1	
228	304-043	MACHINE SCREW (W/WASHERS) M4X10 (BLACK)	1	
229	322-926	LASER COVER (A)	1	
230	322-947	SPECIAL SCREW (C) M5	1	
231	322-938	WASHER M10	2	
232	949-215	MACHINE SCREW M4X8 (10 PCS.)	3	
233	323-040	MACHINE SCREW M5X10 (BLACK)	3	

**PARTS**

C 12FCH

ITEM NO.	CODE NO.	DESCRIPTION	NO. USED	REMARKS	
234	323-040	MACHINE SCREW M5X10 (BLACK)	2		
235	949-431	BOLT WASHER M5 (10 PCS.)	1		
236	323-675	SPINDLE COVER	1		
237	307-028	TAPPING SCREW (W/FLANGE) D4X25 (BLACK)	2		
239	984-750	TAPPING SCREW (W/FLANGE) D4X16	2		
240	937-631	CORD CLIP	1		
241	500-453Z	CORD	1	(CORD ARMOR D10.7)	
242	940-778	CORD ARMOR D10.7	1		
243	959-141	CONNECTOR 50092 (10 PCS.)	2		
244	319-349	CORD BUSH	1		
245		NAME PLATE	1		
246	301-653	TAPPING SCREW (W/FLANGE) D4X20 (BLACK)	4		
247	323-642	SWITCH HANDLE (C)	1		
248	984-750	TAPPING SCREW (W/FLANGE) D4X16	1		
249	322-911	SWITCHING POWER SUPPLY	1		
250	301-653	TAPPING SCREW (W/FLANGE) D4X20 (BLACK)	2		
251	323-645	SWITCH LEVER (A)	1		
252	323-634	SWITCH (A) (1P TYPE)	1		
254	323-695	SWITCH LABEL (C)	1		
255	323-694	SWITCH HANDLE (D) ASS'Y	1	INCLUD. 254	
256	984-750	TAPPING SCREW (W/FLANGE) D4X16	1		
257	320-950	SWITCH (1P SCREW TYPE)	1		
258	323-633	INTERNAL WIRE (A)	1		
259	322-914	HOUSING ASS'Y	1	INCLUD. 260, 261	
260	938-477	HEX. SOCKET SET SCREW M5X8	2		
261	938-241	BRUSH HOLDER	2		
262	999-038	CARBON BRUSH (1 PAIR)	2		
263	945-161	BRUSH CAP	2		
264	303-792	RUBBER RING	1		
265	360-684U	ARMATURE ASS'Y 120V	1	INCLUD. 266, 267, 269, 270	
266	620-2VV	BALL BEARING 6202VVCMP2L	1		
267	980-700	DUST WASHER (B)	1		
268	323-637	LOCK LEVER	1		
269	302-428	WASHER (A)	1		
270	600-0VV	BALL BEARING 6000VVCMP2L	1		
271	322-915	FAN GUIDE	1		
272	953-174	HEX. HD. TAPPING SCREW D5X55	2		
273	340-603C	STATOR ASS'Y 120V	1	INCLUD. 274	
274	937-623	BRUSH TERMINAL	2		
275	322-123	MACHINE SCREW (W/WASHERS) M5X40 (BLACK)	4		

**STANDARD ACCESSORIES**

C 12FCH

ITEM NO.	CODE NO.	DESCRIPTION	NO. USED	REMARKS	
501	944-458	HEX. BAR WRENCH 4MM	1		
502	985-051	BOX WRENCH 17MM	1		
503	322-955	DUST BAG	1		

**OPTIONAL ACCESSORIES**

ITEM NO.	CODE NO.	DESCRIPTION	NO. USED	REMARKS	
601	323-546	CROWN MOLDING STOPPER (L) ASS'Y	1	INCLUD. 602-605	
602	301-806	WING BOLT M6X15	1		
603		CROWN MOLDING STOPPER (L)	1		
604	321-390	CROWN MOLDING STOPPER HOLDER	1		
605	323-682	WING BOLT M6X85	1		
606	323-547	CROWN MOLDING STOPPER (R) ASS'Y	1	INCLUD. 607-610	
607	323-682	WING BOLT M6X85	2		
608	321-390	CROWN MOLDING STOPPER HOLDER	1		
609		CROWN MOLDING STOPPER (R)	1		
610	301-806	WING BOLT M6X15	1		
611	323-657	HOLDER ASS'Y	1	INCLUD. 612-617	
612	321-549	HOLDER	1		
613	949-313	WING NUT M6 (10 PCS.)	1		
614	949-556	NUT M6 (10 PCS.)	1		
615	322-047	WISE PLATE	1		
616	949-425	WASHER M6 (10 PCS.)	1		
617	323-681	HIGH TENSION BOLT M6X105	1		
618	974-561	STOPPER	1		
619	949-404	WING BOLT M6X20 (10 PCS.)	1		
620	323-545	CROWN MOLDING VISE ASS'Y	1	INCLUD. 601, 621	
621	322-957	VISE (B) ASS'Y	1	INCLUD. 622-628	
622	321-551	KNOB BOLT M10X54	1		
623	998-836	KNOB BOLT M6X11	1		
624		SCREW HOLDER (B)	1		
625	306-985	WASHER (H)	1		
626	964-851	BASE RUBBER	1		
627	304-043	MACHINE SCREW (W/WASHERS) M4X10 (BLACK)	1		
628	318-967	VISE SHAFT	1		
629	323-523	GUIDE ASS'Y	1	INCLUD. 607, 611, 618, 619	
630	305-546	TCT SAW BLADE 305MM-D25.4 HOLE-NT60	1		