

RYOBI 10 in. (254 mm) TABLE SAW - MODEL NO. BT3100-1

FOR MITER TABLE ASSEMBLY,
REFER TO FIGURE B

FOR BLADE GUARD ASSEMBLY,
REFER TO FIGURE E

FOR RIP FENCE ASSEMBLY,
REFER TO FIGURE C

FOR MOTOR ASSEMBLY,
REFER TO FIGURE D

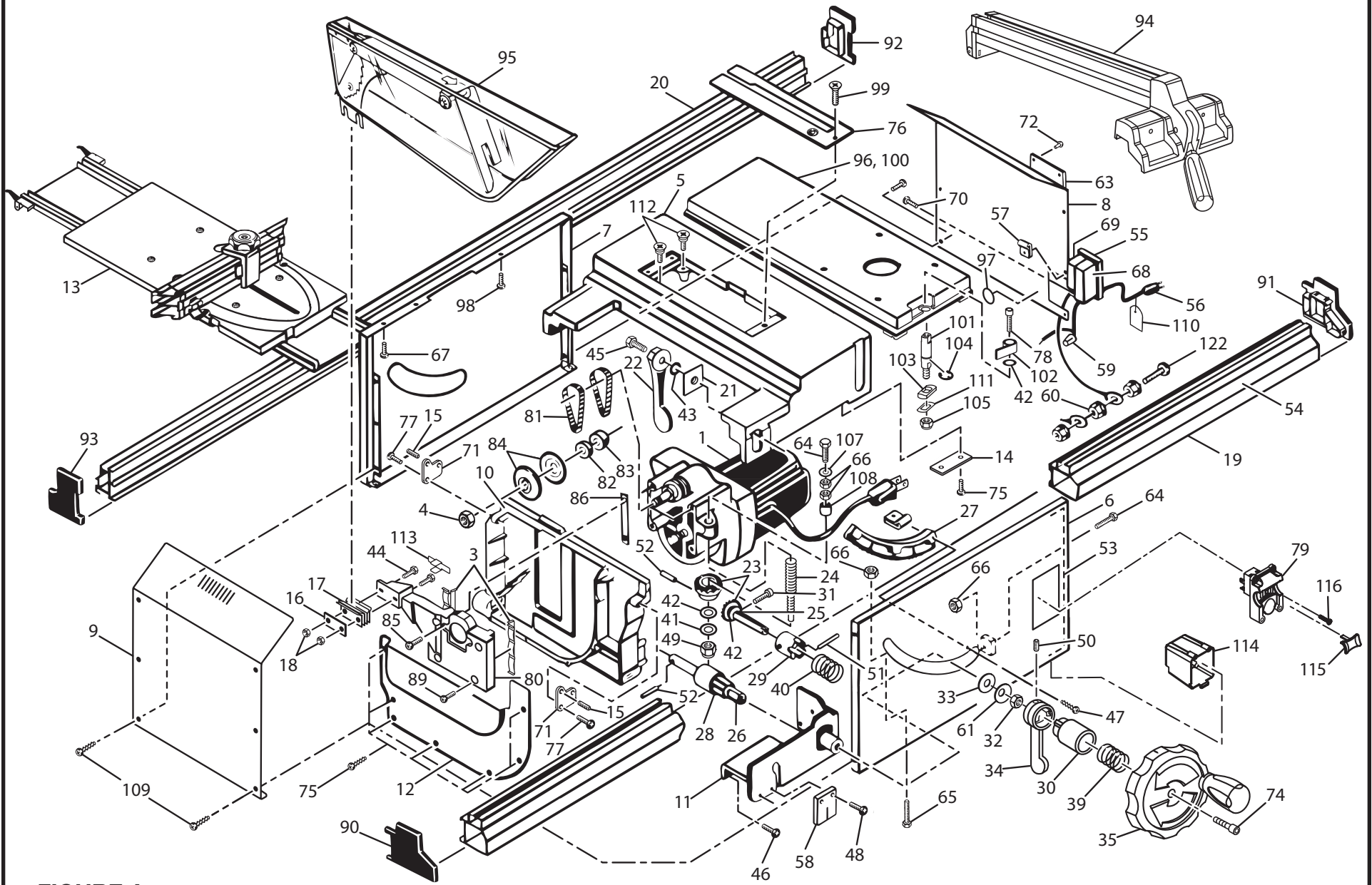

FIGURE A

RYOBI 10 in. (254 mm) TABLE SAW - MODEL NO. BT3100-1

PARTS LIST - FIGURE A

The model number will be found on the data plate attached to the right side panel of the cabinet, next to the saw's on board receptacle. Always mention the model number in all correspondence regarding your **TABLE SAW** or when ordering repair parts.

KEY PART NO. NO.	DESCRIPTION	QTY.	KEY PART NO. NO.	DESCRIPTION	QTY.	
1	969214-010	MOTOR ASSEMBLY.	1	44	615570-007	HEX BOLT (5/16-18 x 1-1/8 in.)... 2
3	0181010314	SHIM.....	2	45	615570-020	HEX BOLT (5/16-18 x 3/4 in.) 4
4	969226-001	HEX NUT (5/8-18).....	1	46	968705-009	SCREW (10-24 x 5/8 in. PAN HD.) 8
5	0181010111-94	SAW TABLE	1			
6	0181010350-94	FRONT CABINET PANEL.....	1	47	662493-002	SCREW (10-24 x 5/8 in. PAN HD.) 3
7	0181010328-94	REAR CABINET PANEL.....	1	48	968703-005	SCREW (8-32 x 3/8 in. PAN HD.)..... 16
8	0181010327-94	RIGHT CABINET PANEL.....	1	49	607406-005	NYLON HEX NUT (3/8-16) 1
9	0181010329-94	LEFT CABINET PANEL	1	50	969218-001	SET SCREW (1/4-20 x 3/8 in.).... 1
10	0181010106	LOCKER BRACKET	1	51	941401-018	ROLL PIN
11	661694-003	CLAMPER BRACKET	1	52	941401-831	ROLL PIN
12	0181010316	DUST COVER.....	1	53	9181015330102	NAME PLATE..... 1
13	A181010802	MITER TABLE ASSEMBLY.....	1	54	9181015330301	SCALE LABEL
14	969113-001	CLAMP PLATE.....	2	55	969137-001	OUTLET (15 AMP SINGLE POLE)..... 1
15	623924-002	NEEDLE ROLLER (1/4 in. x 3/4 in.).....	2	56	969138-001	CORD
16	662481-001	CLAMP	1	57	989001-001	CABLE CLAMP
17	0181010343	SHIM.....	5	58	969140-001	BEVEL INDICATOR..... 1
18	607406-003	HEX NUT (5/16-18).....	2	59	642149-001	WIRE NUT
19	0181010812	FRONT RAIL	1	60	643128-001	LOCK NUT (8-32 HEX)
20	0181011805	REAR RAIL.....	1	61	969142-001	CONE DISC SPRING..... 1
21	969251-002	RAIL HOLDER NUT (5/16)	4	63	9181015332202	DATA PLATE
22	663144-001	RAIL LOCKING CLAMP.....	4	64	615570-012	BOLT (1/4-20 x 1 in. HEX)
23	969122-002	BEVEL GEAR	2	65	615570-011	BOLT (1/4-20 x 2 in. HEX)
24	969123-001	SHAFT	1	66	622171-053	HEX NUT (1/4-20)..... 4
25	969124-001	GEAR SHAFT.....	1	67	968705-004	SCREW (10-24 x 5/16 in. PAN HD.)..... 2
26	969125-002	HANDLE SHAFT	1	68	969230-001	PLUG SOCKET BOX (A)..... 1
27	969126-001	GEAR RACK	1	69	969229-001	PLUG SOCKET BOX (B)..... 1
28	969127-001	TILTING GEAR	1	70	968702-011	SCREW (8-16 x 3/4 in. PAN HD.)..... 4
29	969128-001	CLUTCH	1	71	664087-001	LOCKER SUPPORT
30	969129-002	CAM.....	1	72	0181010923	RIVET..... 4
31	998292-002	SCREW (8-32 x 1-3/16 in. FIL. HD.).....	1	73	662079-001	SET SCREW (10-24 x 3/8 in.).... 4
32	607406-006	HEX NUT (3/4-16)	1	74	410151710	CAP SCREW
33	661796-001	WASHER.....	1	75	968705-040	SCREW (10-24 x 1/2 in. PAN HD.)..... 11
34	969130-001	BEVEL LOCKING LEVER.....	1	76	0181010342	THROAT PLATE..... 1
35	A181014002	BLADE ADJUSTING HANDLE	1	78	969220-002	CAP SCREW
39	969222-001	SPRING	1	79	984407-001	SWITCH (INC. KEY NO. 115) 1
40	969221-001	SPRING	1			
41	706382-359	WASHER.....	1			
42	706382-360	WASHER.....	3			
43	706382-346	WASHER.....	4			

RYOBI 10 in. (254 mm) TABLE SAW - MODEL NO. BT3100-1
PARTS LIST - FIGURE A (CONT'D)

KEY PART NO. NO.	DESCRIPTION	QTY.	KEY PART NO. NO.	DESCRIPTION	QTY.		
80	0181010110	GUIDE HOLDER.....	1	99	410101012	SCREW (10-24 x 3/4 in. FLAT HD.).....	1
81	662329-001	V BELT.....	2	100	0181010102-94	ACCESSORY TABLE.....	1
82	662062-001	1/4 in. SPACER.....	1	101	969174-004	HANDLE SHAFT.....	1
83	662062-002	1/2 in. SPACER.....	1	102	969175-002	HANDLE.....	1
84	969205-001	BLADE WASHER.....	2	103	969216-001	SPRING PLATE.....	1
85	614658-007	SCREW (8-32 x 3/4 in. PAN HD.).....	3	104	623111-001	RETAINING EXTENSION.....	1
86	969600-001	SHIM.....	2	105	644585-002	HEX NUT (1/4-20).....	1
89	968705-015	SCREW (10-24 x 1 in. PAN HD.).....	4	107	706382-343	WASHER.....	1
90	0181010241	END PLUG F1 (FRONT LEFT) ...	1	108	661853-001	SPACER.....	1
91	0181010242	END PLUG F2 (FRONT RIGHT) .	1	110	663339-001	HANG TAG.....	1
92	0181010236	END PLUG R1 (RIGHT REAR) ...	1	111	661992-002	BACK-UP PLATE.....	1
93	0181010237	END PLUG R2 (LEFT REAR)	1	112	0181010813	SHOULDER SCREW (10-24 x 3/4 in. FLAT HD.).....	2
94	A181010901	RIP FENCE ASSEMBLY.....	1	113	662080-001	BOLT HOLDER.....	1
95	969165-001	BLADE GUARD ASSEMBLY.....	1	114	0181010264	REAR SWITCH COVER.....	1
96	A181012002	* ACCESSORY TABLE ASSEMBLY.....	1	115	984407-0030	SWITCH KEY.....	1
97	9181015335701	GROUNDING LABEL.....	1	116	410191005	SCREW.....	4

* Item 96 includes parts 42, 78, 100 through 106, and 111.

RYOBI 10 in. (254 mm) TABLE SAW - MODEL NO. BT3100-1
FIGURE B: SLIDING MITER TABLE ASSEMBLY

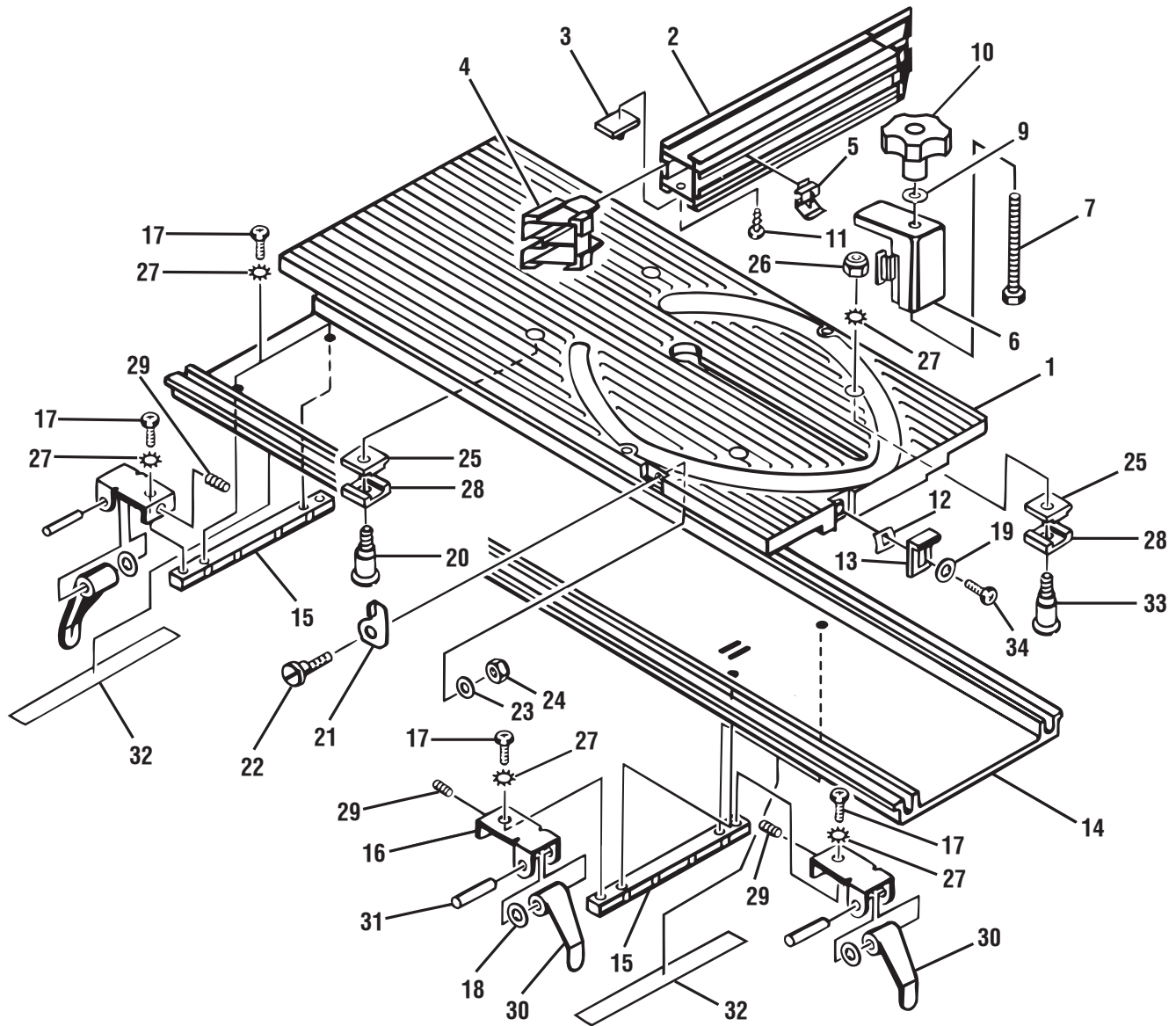

KEY NO.	KEY NO.	PART DESCRIPTION	QTY.	KEY NO.	KEY NO.	PART DESCRIPTION	QTY.
1	0181010101-94	MITER TABLE TOP	1	18	607617-003	O-RING.....	4
2	969188-001	MITER FENCE	1	19	621721-010	WASHER	1
3	661811-001	PIVOT.....	1	20	969502-001	ECCENTRIC SCREW (10-24).....	3
4	969190-001	SAW GAGE	2	21	969500-001	QUICK STOP.....	1
5	969191-002	MITER INDICATOR	1	22	969501-002	ECCENTRIC SCREW (8-32).....	1
6	969192-001	MITER FENCE HOLDER	1	23	621721-001	WASHER	1
7	615570-010	BOLT (5/16-18 x 3-1/4 in. HEX HD.).....	1	24	703477-006	HEX NUT (ELASTIC STOP)	1
9	706382-357	WASHER.....	1	25	661844-001	SLIDE (A)	4
10	662285-001	ADJUSTING CLAMP.....	1	26	703477-059	HEX NUT (ELASTIC STOP)	4
11	968702-009	SCREW (8-16 x 5/8 in. PAN HD.).....	2	27	621032-002	LOCK WASHER	12
12	969227-001	SPRING PLATE	1	28	661845-001	SLIDE (B)	4
13	969225-001	MITER SLIDE LOCK.....	1	29	969218-005	SET SCREW (10-24 x 1/4 in. HEX SOCKET).....	4
14	969228-003	MITER BASE	1	30	969915-002	MITER LOCKING CLAMP	4
15	664137-001	GUIDE BAR	2	31	941401-308	ROLL PIN	4
16	969916-006	HOLDER PLATE.....	4	32	661706-001	GUIDE PLATE.....	2
17	968705-041	SCREW (10-24 x 15/32 in. PAN HD.).....	8	33	662306-001	NON-ECCENTRIC SCREW (10-24)	1
				34	968705-007	SCREW (10-24 x 1/2 in. PAN HD.).....	1

RYOBI 10 in. (254 mm) TABLE SAW - MODEL NO. BT3100-1
FIGURE C: RIP FENCE ASSEMBLY

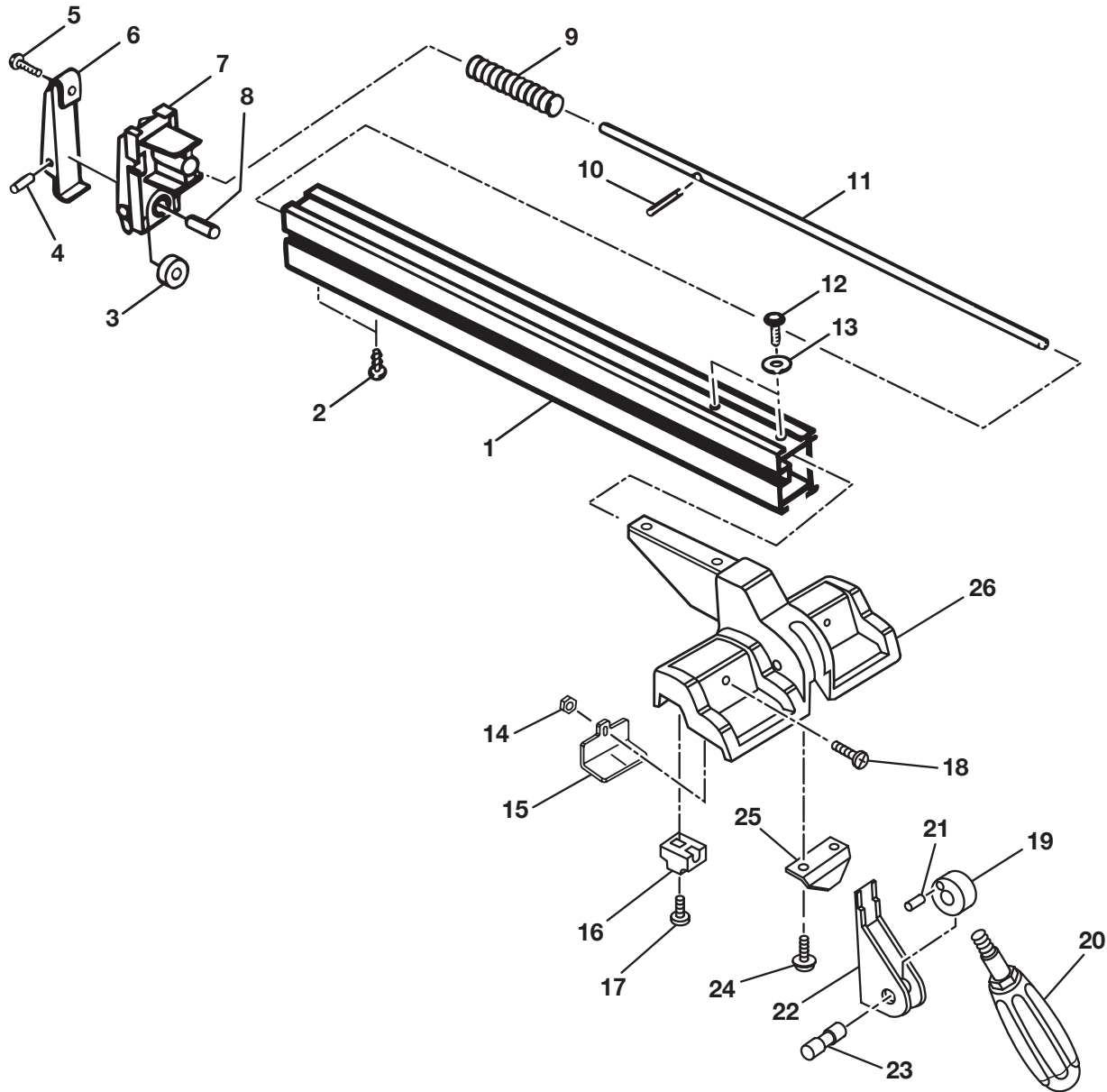

KEY NO.	PART NO.	DESCRIPTION	QTY.	KEY NO.	PART NO.	DESCRIPTION	QTY.
1	969144-001	RIP FENCE	1	14	706404-007	HEX NUT (8-32)	1
2	968704-006	SCREW (10-14 x 1/2 in. PAN HD.)	2	15	0181010243	SCALE INDICATOR	1
3	969155-001	FENCE ROLLER	1	16	969240-001	SLIDE	2
4	941401-309	ROLL PIN	1	17	968703-007	SCREW (8-32 x 1/2 in. PAN HD.)	2
5	607067-007	SCREW (10-24 x 1 in. PAN HD.)	1	18	410131719	SCREW	1
6	969254-001	CLAMPER - B	1	19	969146-003	ECCENTRIC ROLLER	1
7	969154-002	ROLLER HOLDER	1	20	A0181010227	LOCKING HANDLE	1
8	969114-001	DOWEL PIN (1/4 in. x 3/4 in.)	1	21	623019-004	RUBBER PLUG	1
9	969253-001	COMPRESSION SPRING	1	22	969252-001	CLAMPER - A	1
10	941401-833	ROLL PIN	1	23	969147-002	PIN	1
11	969156-001	ROD	1	24	968703-005	SCREW AND WASHER	2
12	610878-003	SCREW (1/4-20 x 5/8 IN. BUTTON HD.)	2	25	969150-001	PLATE	1
13	706382-358	WASHER	2	26	0181010115-58	FRONT BLOCK	1

RYOBI 10 in. (254 mm) TABLE SAW - MODEL NO. BT3100-1

FIGURE D: MOTOR ASSEMBLY

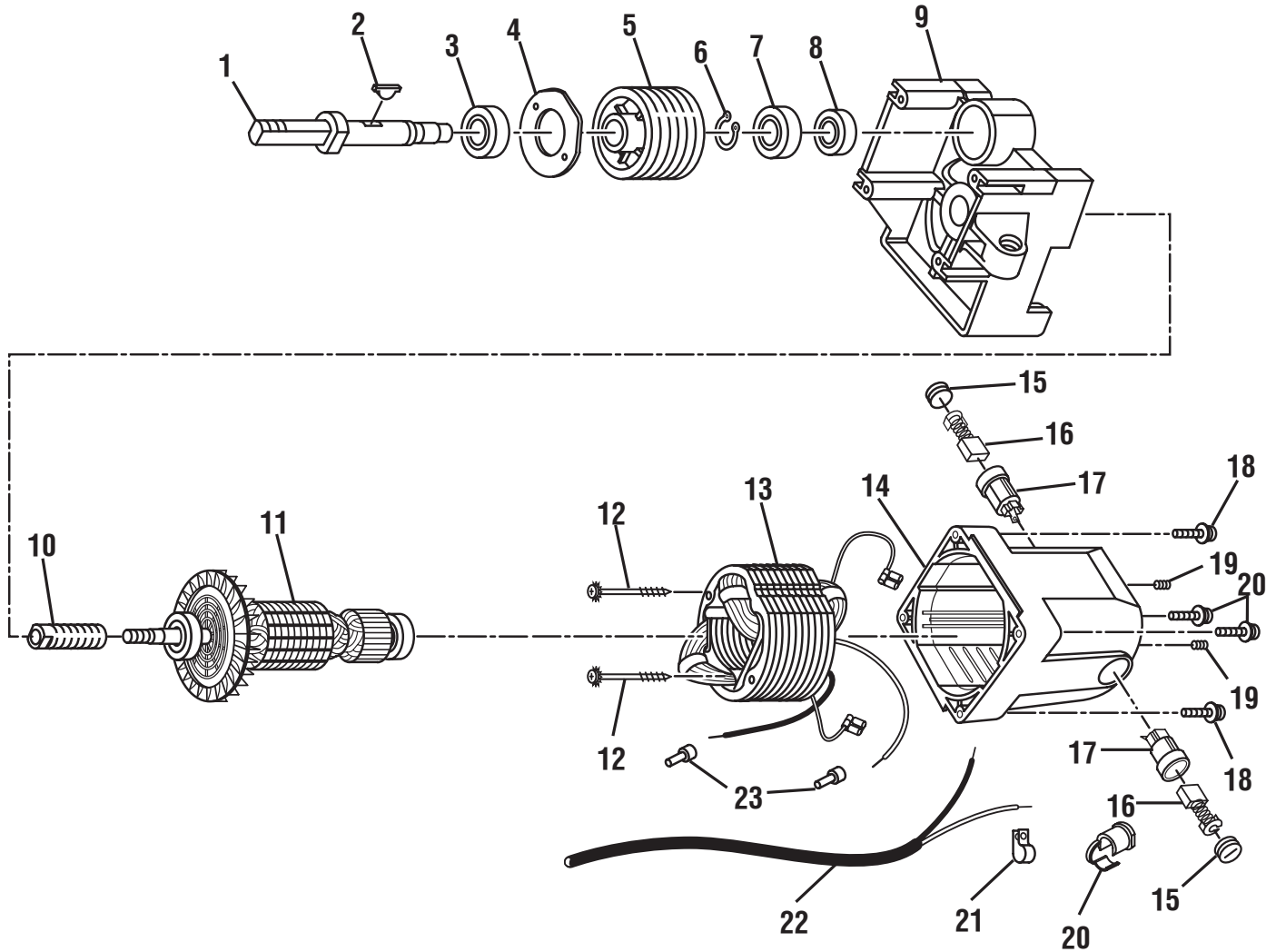

KEY NO.	PART NO.	DESCRIPTION	QTY.	KEY NO.	PART NO.	DESCRIPTION	QTY.
1	969209-001	ARBOR.....	1	13	4500008	FIELD ASSEMBLY.....	1
2	616452-010	WOODRUFF KEY (3/16 in.)	1	14	4800030	MOTOR HOUSING.....	1
3	969235-003	BALL BEARING (6003)	1	15	4570009	BRUSH COVER.....	2
4	969203-001	BEARING PLATE	1	16	4540007	BRUSH ASSEMBLY	2
5	969210-002	ARBOR PULLEY.....	1	17	4570008	BRUSH HOLDER ASSY.	2
6	622167-068	RETAINING RING	1	18	4130267	SCREW AND WASHER (PAN HD.)	4
7	969235-004	BALL BEARING (6002)	1	19	4130266	SET SCREW (HEX).....	2
8	969235-005	BALL BEARING (6200ZZ).....	1	20	4520017	STRAIN RELIEF BUSHING	1
9	4800031	MOTOR BRACKET	1	21	4520018	CABLE CLAMP	1
10	4860022	MOTOR PULLEY	1	22	4520016	POWER CORD.....	1
11	4460008	ARMATURE ASSEMBLY.....	1	23	4560026	CONNECTOR.....	2
12	4130268	SCREW AND WASHER (FIELD PAN HD.).....	2				

RYOBI 10 in. (254 mm) TABLE SAW - MODEL NO. BT3100-1
FIGURE F: BLADE GUARD ASSEMBLY

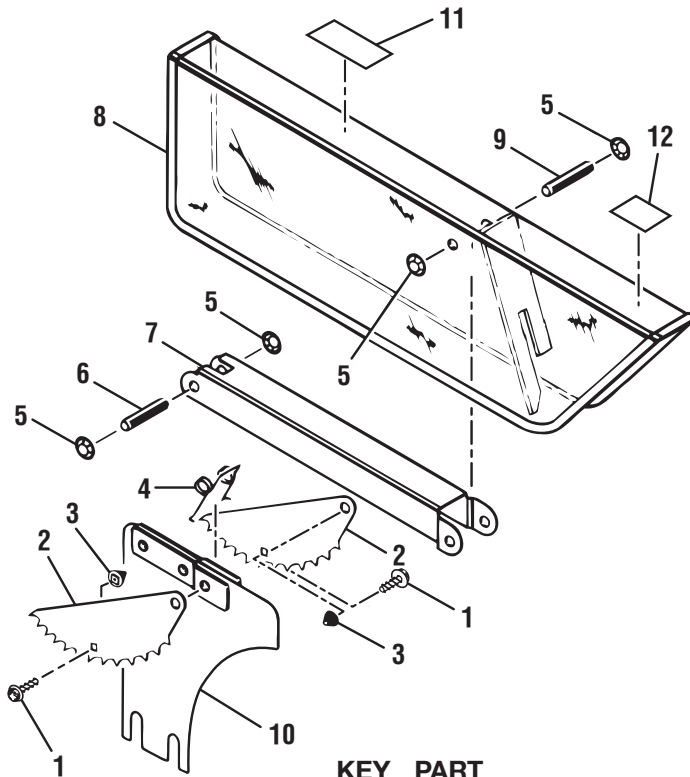

KEY NO.	PART NO.	DESCRIPTION	QTY.	KEY NO.	PART NO.	DESCRIPTION	QTY.
1	968700-004	SCREW AND WASHER.....	2	7	969610-002	ARM.....	1
2	969169-001	ANTI-KICKBACK FINGERS.....	2	8	969612-001	COVER	1
3	662002-001	SPACER CAP	2	9	969170-002	DOWEL PIN.....	1
4	969608-001	TORSION SPRING.....	1	10	969168-005	RIVING KNIFE ASSEMBLY.....	1
5	969233-010	PUSH NUT	4	11	9181015330201	WARNING LABEL.....	1
6	969170-001	DOWEL PIN.....	1	12	9181015330202	HAND WARNING LABEL.....	1

FIGURE F: REPLACEMENT PARTS

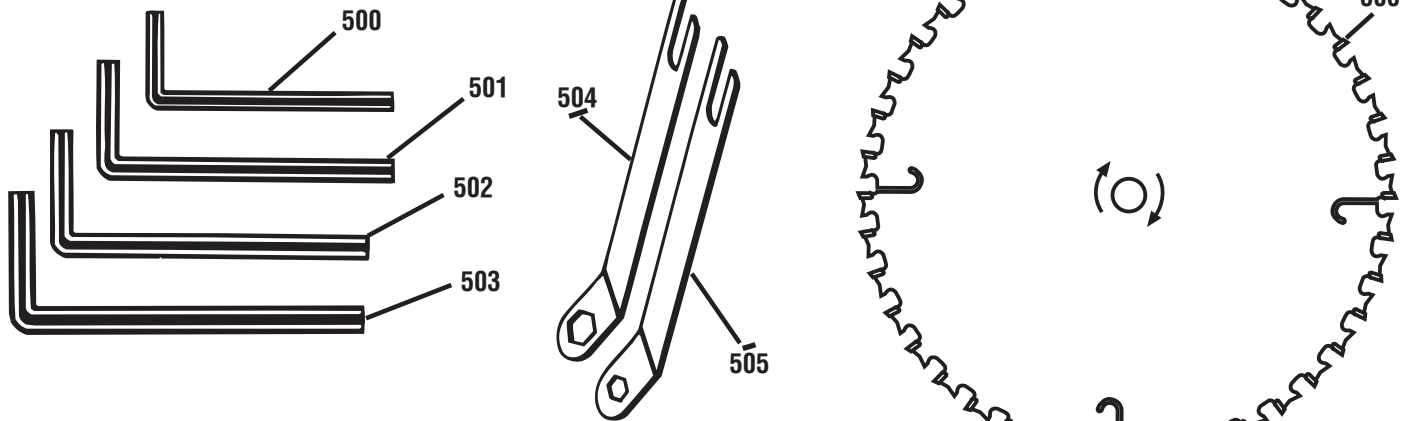

KEY NO.	PART NO.	DESCRIPTION	QTY.	KEY NO.	PART NO.	DESCRIPTION	QTY.
500	820193-004	3/32 in. HEX KEY.....	1	504	969244-003	LARGE WRENCH.....	1
501	820193-005	1/8 in. HEX KEY.....	1	505	969244-004	SMALL WRENCH.....	1
502	820193-006	5/32 in. HEX KEY.....	1	506	969196-001	SAW BLADE.....	1
503	820193-007	3/16 in. HEX KEY.....	1				

RYOBI 10 in. (254 mm) TABLE SAW - MODEL NO. BT3100-1

The model number will be found on the data plate attached to the right side panel of the cabinet, next to the saw's on board receptacle. Always mention the model number in all correspondence regarding your **TABLE SAW** or when ordering repair parts.

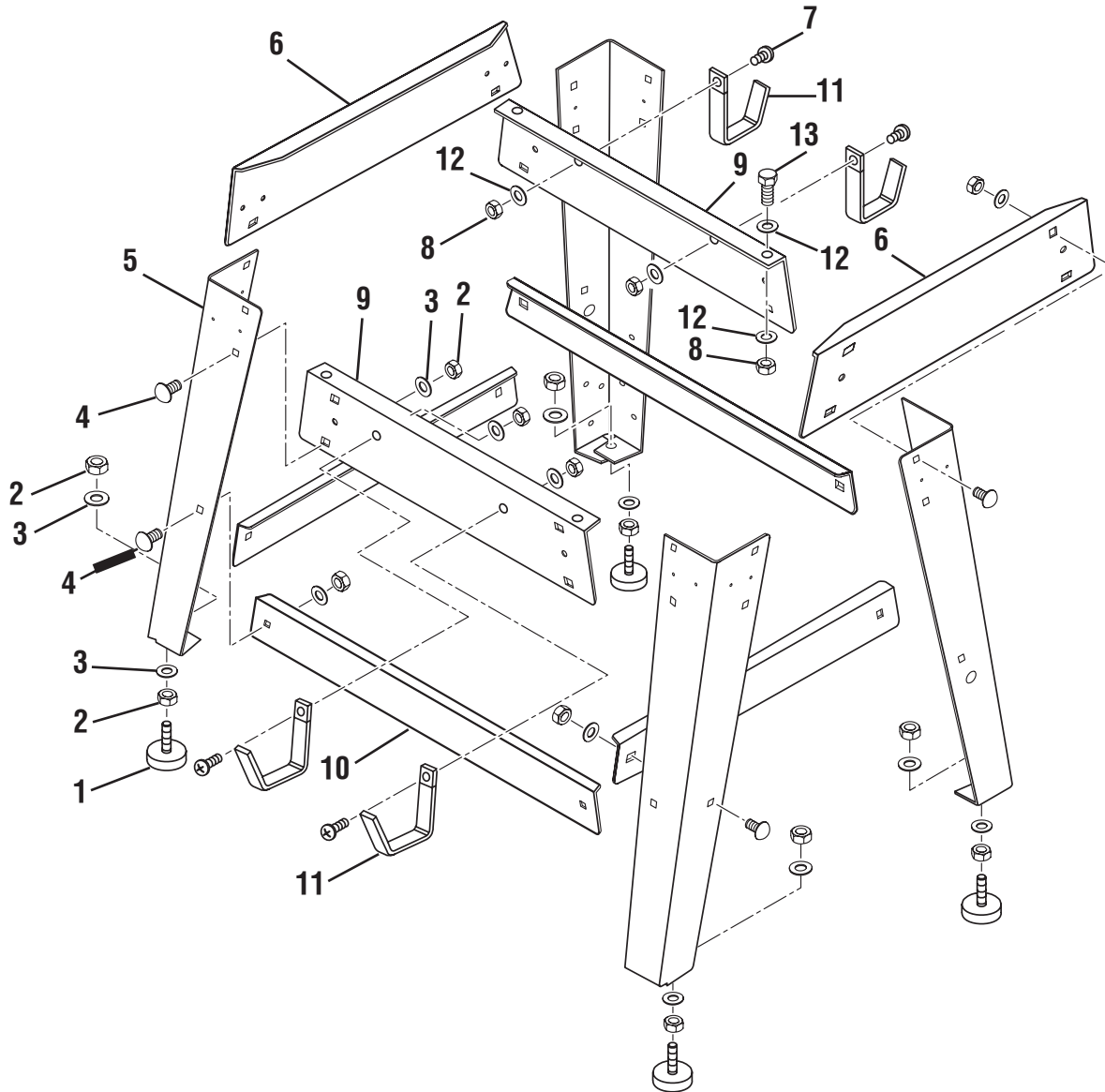

FIGURE G

RYOBI 10 in. (254 mm) TABLE SAW - MODEL NO. BT3100-1

The model number will be found on the data plate attached to the right side panel of the cabinet, next to the saw's on board receptacle. Always mention the model number in all correspondence regarding your **TABLE SAW** or when ordering repair parts.

PARTS LIST FOR FIGURE G

KEY NO.	PART NO.	DESCRIPTION	QTY.
1	0181010238	LEVELING FOOT	4
2	411011710	HEX NUT	32
3	412011067	WASHER	32
4	410031704	CARRIAGE BOLT	24
5	0181010338-94	LEG	4
6	0181010335-94	UPPER BRACE	2
7	410131722	SCREW	4
8	411011707	HEX NUT	8
9	0181010336-94	UPPER SIDE BRACE.....	2
10	0181010337-94	LOWER BRACE	4
11	0181010334	STORAGE BRACKET	4
12	412011069	WASHER.....	12
13	410011710	BOLT.....	4
	A181011501	STAND FASTENER ASSEMBLY	1
	983000232	OPERATOR'S MANUAL	
	02-04-08		
	(REV:01)		