

Tanaka[®]



Parts Catalog



Auto-Start Trimmer

Model: AST-5000

Part # 10432 2-14-97

AST-5000

OPTIONS AND ACCESSORIES

NYLON LINE



- 746156 .095, Box, 50 ft.
- 746157 .105, Box, 50 ft.
- 746160 .095, 1/2 lb. Box, 143 ft.
- 746161 .105, 1/2 lb. Box, 110 ft.
- 746165 .095, 1 lb. Box, 285 ft.
- 746166 .105, 1 lb. Box, 235 ft.
- 746169 .095, 3 lb. spool, 855 ft.
- 746170 .105, 3 lb. spool, 705 ft.
- 746173 .095, 5 lb. spool, 1425 ft.
- 746174 .105, 5 lb. spool, 1175 ft.

SEMI-AUTO HEAD

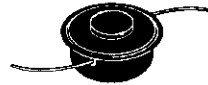

746152 PNH-170

Parts List

- | | |
|---------|---------|
| SN-341 | Housing |
| SE-103 | Eyelets |
| UA-1006 | Adapter |
| SN-354 | Spring |
| SN-349 | Spool |
| SN-347 | Button |
| SN-348 | Cover |

ALUMINUM MANUAL HEAD



PCH-100
(746180)

PCH-300
(746190)

PERFECT MIX® 2-Cycle Engine Oil

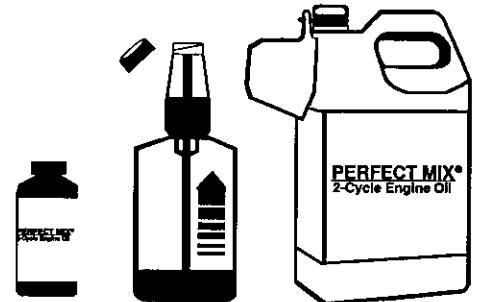

- 700109 2.8 oz. Bottle, 1 Gallon Size (24*)
 - 700108 16 oz. Self-measuring Bottle (24*)
 - 700110 1 Gallon Jug Commercial Size (6*)
- * Case Quantity

SHOULDER STRAPS

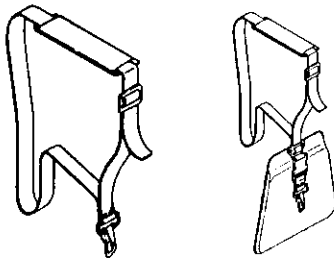

PSS-175

SS-250*

* Requires 355-37302-900

MISCELLANEOUS

- | | |
|---------------|--------------------------------|
| 10530 | Owner's Manual |
| 10432 | Parts Catalog |
| WSM-TBC | Service Manual |
| 756-0634F-900 | Recoil Starter Kit
(fig. 9) |

SPECIAL TOOLS

- | | | | |
|---------------|--------------------|---------------|-----------------|
| 006-29326-000 | Flywheel Remover | 001-29000-000 | Tachometer |
| 009-29323-500 | Piston Pin Remover | 070-2000W-500 | Pressure Tester |
| 037-29476-522 | Clutch Remover | 070-2000W-501 | Carb. Tool Kit |



FIG. 1 ENGINE

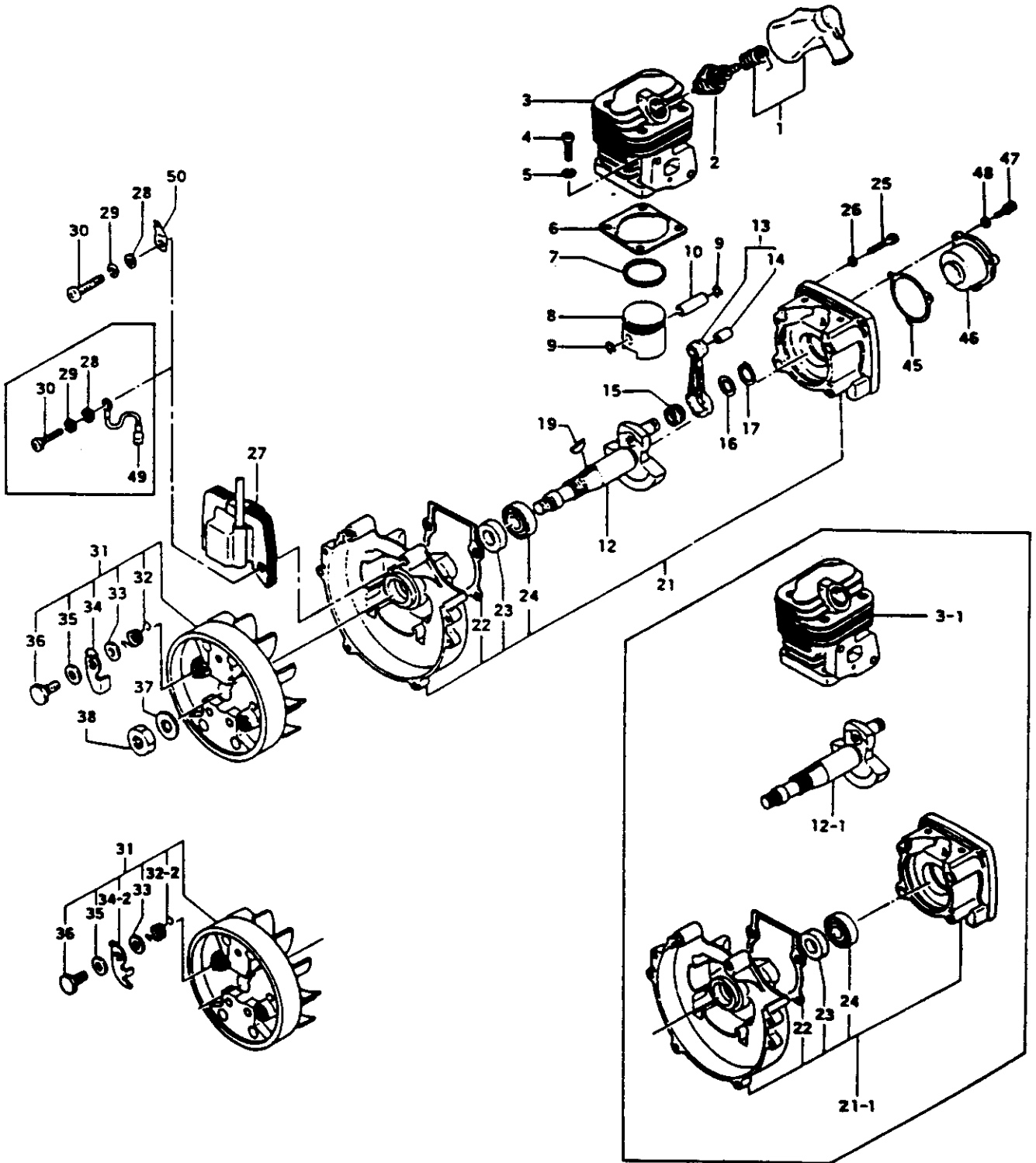

FIGURE 1

AST-5000 PARTS LISTING

REF.	PART NO.	PART DESCRIPTION	Q	C	S	SERIAL NO.	REMARKS
1	157-0097A-900	CAP,SPARK PLUG,ASS'Y	1		B		
2	018-11660-21	PLUG,SPARK	1		B		
3	002-0634F-200	CYLINDER	1		B	~H055221	
3-1	002-0634F-21	CYLINDER	1		C	H055222~	
4	990-11050-181	SCREW,5X18	4		B		
5	992-10050-012	WASHER,S,5	4		A		
6	017-0631A-200	GASKET,CYLINDER	1		B		
7	041-00000-210	RING,PISTON,LOWER	1		A		
8	031-0634F-201	PISTON	1		C		
9	039-06100-200	CIRCLIP,PISTON PIN	2		A		
10	037-06097-200	PIN,PISTON	1		B		
12	059-0634F-200	CRANKSHAFT,DRIVE SIDE	1		D	~H055221	
12-1	059-0634F-210	CRANKSHAFT,DRIVE SIDE	1		D	H055222~	
13	061-0634F-80	ROD,CONNECTING	1		D		
14	999-62071-127	BEARING,NEEDLE,F-79	1		C		
15	999-62101-432	BEARING,NEEDLE,10148	1		D		
16	801-10205-202	WASHER,PULLEY	1		D		
17	993-50010-002	RING,STOP,C-10 EX	1		C		
19	068-10100-200	KEY,WOODRUFF,3X13X4.5	1		C		
21	072-0634F-900	CRANKCASE,ASS'Y	1		C	~H055221	Includes gasket, bearing and seal
21-1	072-0634F-910	CRANKCASE,ASS'Y	1		C	H055222~	Includes gasket, bearing and seal
22	090-06097-200	GASKET,CRANKCASE	1		C		
23	999-66152-511	SEAL,OIL,#VE15X25X7	1		A		
24	999-61600-200	BEARING,BALL,#6002	1		B		
25	990-11050-251	SCREW,5X25	4		D		
26	992-10050-012	WASHER,S,5	4		A		
27	167-20508-800	COIL,IGNITION	1		C		
28	992-00050-011	WASHER,SMALL,5	2		C		
29	992-10050-012	WASHER,S,5	2		A		
30	990-11050-201	SCREW,MX20	2		D		
31	155-20514-901	ROTOR,MAGNETO ASS'Y	1		D		
32	790-0633M-202	SPRING,PAWL	2		D	~H033200	
32-2	790-0633M-210	SPRING,PAWL	2		D	H033201~	
33	786-00601-200	WASHER,RECOIL STARTER	2		D		
34	788-0633M-201	PAWL,STARTER	2		D	~H033200	
34-2	788-0633M-210	PAWL,STARTER	2		D	H033201~	
35	822-00601-200	SHIM,7X11.8X.60	2		C		
36	793-10200-202	BOLT,STEP	2		C	~J147780	
36	793-0636T-200	BOLT,STEP	1		D	J147781~	

* Indicates the part is included in a kit or assembly and is not available individually. Q=Quan. used
C=Interchangeability S=Stocking code: A=Fast moving B=Med. fast C=Med. move D=Slow move
E=N.L.A. F=Superseded or replaced by a new part

FIGURE 1 cont.

AST-5000 PARTS LISTING

REF.	PART NO.	PART DESCRIPTION	Q	C	S	SERIAL NO.	REMARKS
37	992-00120-011	WASHER,12	1		D		
38	991-11120-011	NUT,12	1		A		
45	317-0634F-200	PACKING,LID	1		B		
46	078-0634F-200	LID,CRANK CASE	1		D		
47	990-11050-121	SCREW,5X12	3		A	~H253160	
47	990-51050-123	BOLT,HEX,5X12	3		C	H253161~	
48	992-10050-012	WASHER,S,5	3		B		
49	274-0136U-800	CORD,EARTH	1		D		
50	205-0634F-200	TAB	1		D	J065552~	

* Indicates the part is included in a kit or assembly and is not available individually. Q=Quan. used
 C=Interchangeability S=Stocking code: A-Fast moving B=Med. fast C=Med. move D=Slow move
 E=N.L.A. F=Superseded or replaced by a new part

FIG.2 ENGINE COMPONENTS

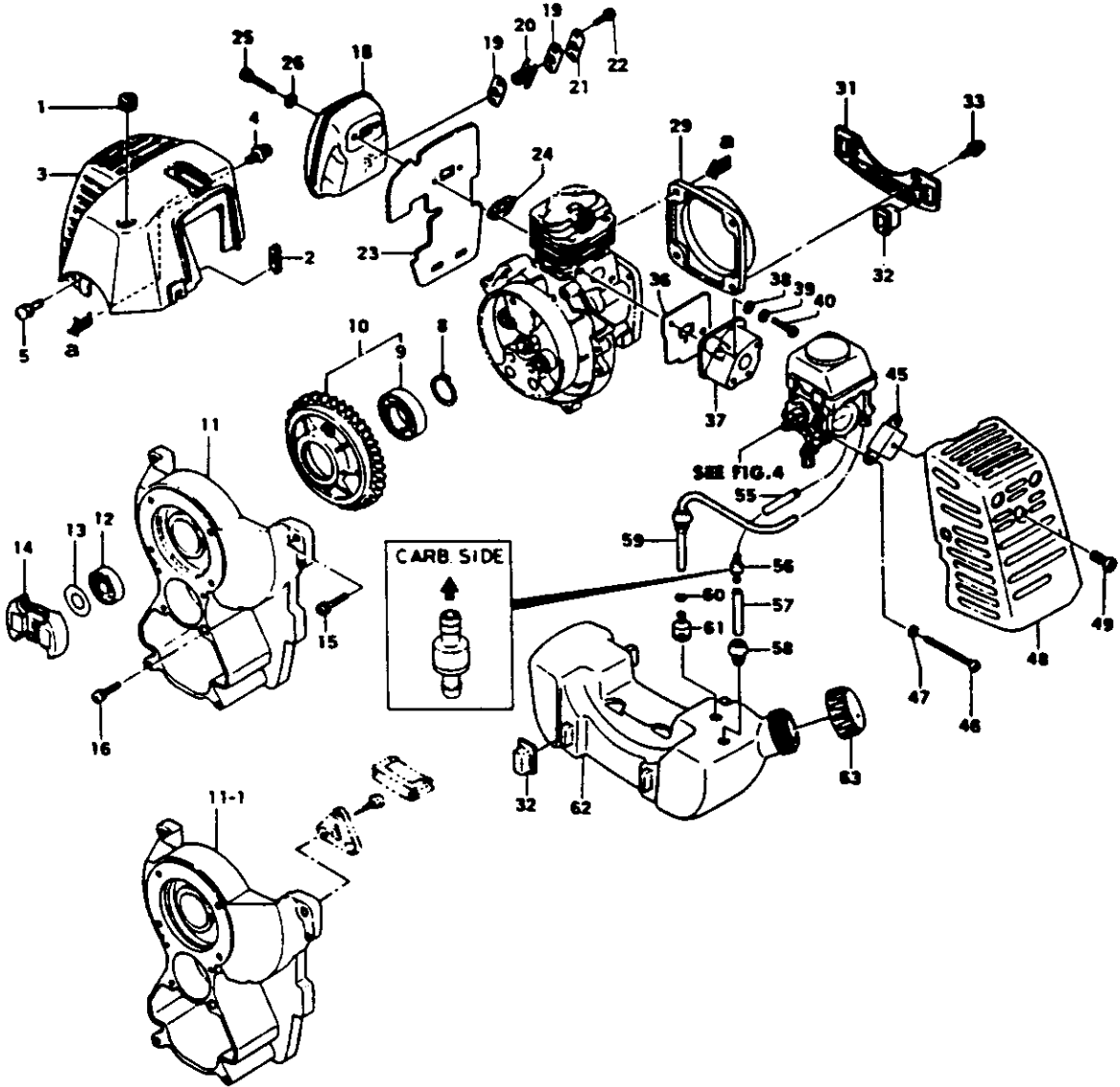

FIGURE 2

AST-5000 PARTS LISTING

REF.	PART NO.	PART DESCRIPTION	Q	C	S	SERIAL NO.	REMARKS
1	202-01003-201	GROMMET,SECONDARY CORD	1		C		
2	203-0631A-200	GROMMET	1		D		
3	738-0631A-201	PROTECTOR,MUFFLER	1		B		
4	994-15040-222	SCREW,PS,4X22	2		A		
5	994-15040-122	SCREW,4X12/PS	2		C	~H253160	
5	990-72045-164	SCREW,TAPPING,4.5X16	2		C	H253161~	
8	993-50017-002	RING,STOP,C17 EX	1		B		
9	999-61600-301	BEARING,BALL,6003ZZ	1		D		
10	774-0634F-800	PULLEY,STARTER	1		D		
11	112-0634F-200	CASE,FAN	1		D	~H253160	
11-1	112-0634F-82	CASE,FAN	1		D	H253160~	
12	999-61600-001	BEARING,BALL,#6000ZZ	1		B		
13	173-35500-200	SHIM,10.1X16X.20	V		C		Shims are as needed to obtain correct C/S end play.
13	174-35500-200	SHIM,10.1X16X.30	V		C		
13	175-35500-200	SHIM,10.1X16X1.0	V		C		
14	277-0635M-800	CLUTCH	1		D		Improved type with lining
15	994-16050-202	SCREW,5X20/WS	1		D		
16	994-16050-422	SCREW,5X42/WS	3		C		
18	706-0631A-801	MUFFLER	1		D		
19	751-04200-201	GASKET,MUFFLER	2		C		
20	732-0631A-200	ARRESTER,SPARK	1		C		
21	734-0631A-20	PIPE,TAIL	1		C		
22	994-14040-081	SCREW,4X8	2		D		
23	133-0631A-201	SHIELD,HEAT	1		B		
24	737-06100-21	GASKET,MUFFLER	1		D		
25	990-51050-503	BOLT,HEX,5X50	2		C		
26	992-01050-011	WASHER,5	2		C		
29	218-0634F-200	COVER,CRANK CASE	1		C		
31	653-0631A-200	BRACKET,TANK	1		C		
32	655-00940-201	CUSHION,FUEL TANK	4		A		
33	994-15040-222	SCREW,PS,4X22	2		A		
36	403-0631A-202	GASKET,INLET MANIFOLD	1		A		
37	404-0631P-800	INSULATOR,CARBURETOR	1		D		
38	992-00050-011	WASHER,SMALL,5	2		C		
39	992-10050-012	WASHER,S,5	2		A		
40	990-11050-221	SCREW,5X22	2		B		
45	476-0631P-200	BOARD,BLOW OVER CHECK	1		D		
46	990-11040-551	SCREW,4X55	2		D		
47	992-10040-012	WASHER,S,4	1		B		

* Indicates the part is included in a kit or assembly and is not available individually. Q=Quan. used
 C=Interchangeability S=Stocking code: A-Fast moving B=Med. fast C=Med. move D=Slow move
 E=N.L.A. F=Superseded or replaced by a new part

FIGURE 2 cont.

AST-5000 PARTS LISTING

REF.	PART NO.	PART DESCRIPTION	Q	C	S	SERIAL NO.	REMARKS
48	452-0631P-200	COVER,CLEANER	1		C		
49	380-0631A-200	BOLT,CLEANER COVER	1		B		
55	700-03005-030	PIPE,FUEL,3X5X30	1		B		
56	586-25108-901	VALVE,CHECK,ASS'Y	1		C		
57	700-03005-065	PIPE,FUEL,3X5X65	1		D		
58	222-06300-200	GROMMET,FUEL PIPE	1		B		
59	223-0162V-900	PIPE,FUEL,ASS'Y	1		B		
60	680-00731-201	CLIP 6.3	1		B		
61	675-04042-80	FILTER,FUEL	1		A		
62	591-0633R-21	TANK,FUEL	1		A		
63	595-0650A-90	CAP,TANK	1		A		

* Indicates the part is included in a kit or assembly and is not available individually. Q=Quan. used
 C=Interchangeability S=Stocking code: A-Fast moving B=Med. fast C=Med. move D=Slow move
 E=N.L.A. F=Supersceded or replaced by a new part

FIG.3 CARBURETOR

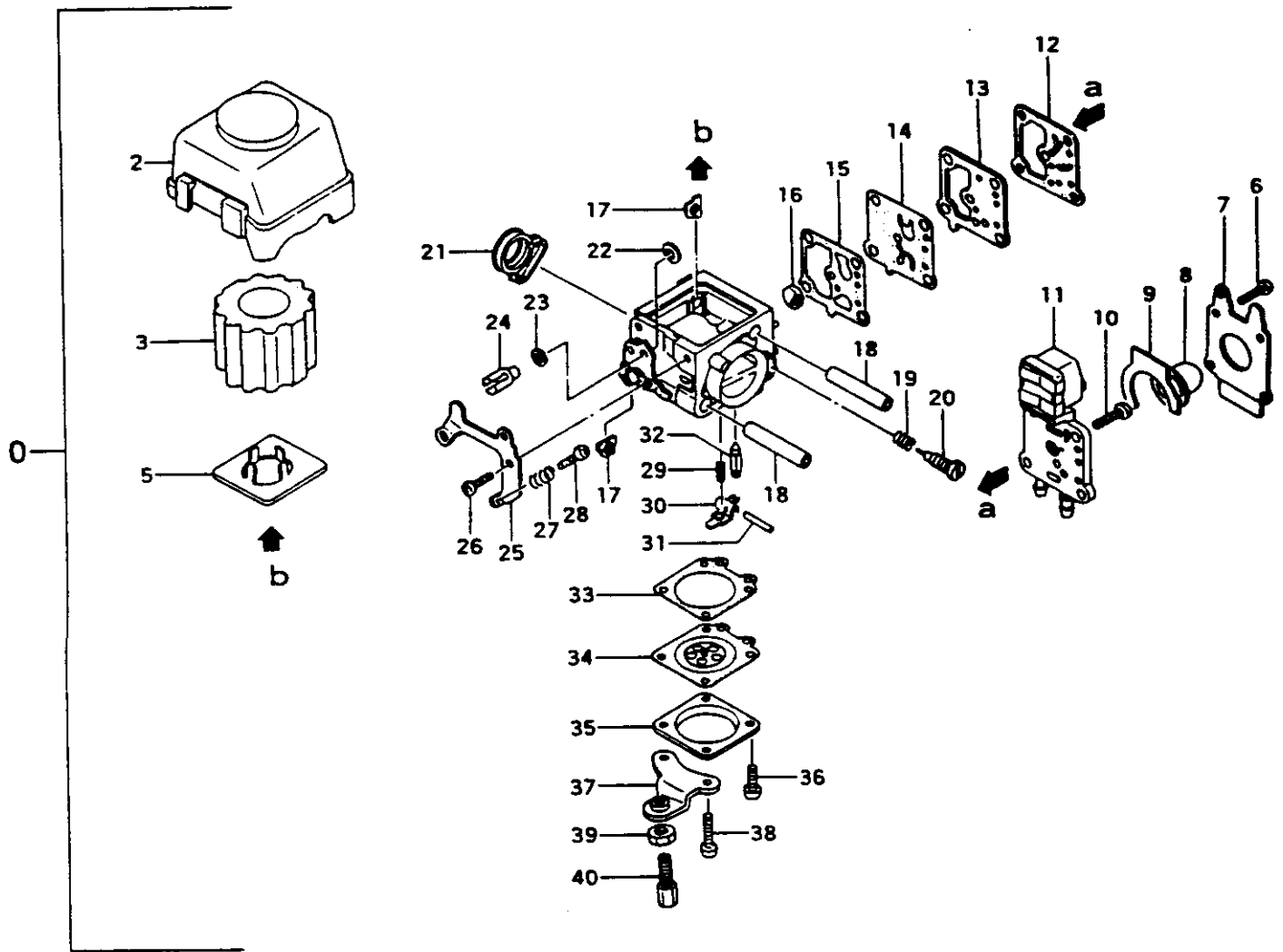

FIGURE 3

AST-5000 PARTS LISTING

REF.	PART NO.	PART DESCRIPTION	Q	C	S	SERIAL NO	REMARKS
0	455-25118-900	CARBURETOR,ASS'Y	1		D	~L005290	
0	455-25138-90	CARBURETOR,ASS'Y	1		C	L005291~	
2	424-0631P-200	CAP,CLEANER	1		B		
3	421-0631P-200	ELEMENT,CLEANER	1		B		
5	425-0631P-200	BASE,CLEANER	1		D		
6	548-25108-200	SCREW,SET	4		D		
7	452-25108-200	COVER,PRIMING PUMP	1		B		
8	447-25108-200	BULB,PRIMING	1		A		
9	----	*GASKET,OVER FLOW	1		D		
10	548-25108-200	SCREW,SET	1		D		
11	575-25108-800	BODY,PUMP	1		C		
12	----	*GASKET,PUMP PLATE	1		D		
13	523-25108-200	PLATE,PUMP	1		C		
14	----	*DIAPHRAGM,PUMP	1		C		
15	----	*GASKET,PUMP DIAPHRAGM	1		C		* Included in Carb. Repair Kit
16	----	*SCREEN,INLET	1		D		650-25108-910
17	636-25108-200	PLATE,SLEEVE	2		D		(Not available individually)
18	437-25108-200	SLEEVE	2		C		
19	485-25108-200	SPRING,ADJUST,HIGH	1		D		
20	460-25108-200	SCREW,HIGH ADJUST	1		C		
21	449-0631P-200	GASKET,CARBURETOR	1		C		
22	489-25100-200	RING,STOP	1		C		
23	549-25100-200	WASHER,THRUST	1		D		
24	539-25101-200	SWIVEL	1		D		
25	544-25108-200	STAY,ADJUSTER	1		D		
26	514-25108-200	SCREW,SET	2		D		
27	463-25100-200	SPRING,IDLE ADJUST	1		C		
28	462-25100-20	SCREW,IDLE ADJUST	1		C		
29	477-25013-200	SPRING,VALVE	1		D		
30	----	*HINGE,VALVE	1		C		
31	----	*PIN,FLOAT	1		D		
32	----	*VALVE,NEEDLE	1		C		
33	----	*GASKET,DIAPHRAGM	1		A		
34	----	*DIAPHRAGM,METERING	1		A		
35	476-25004-200	COVER,DIAPHRAGM	1		D		
36	514-25105-200	SCREW,SET	2		D		
37	614-25108-200	STAY,CABLE ADJUSTER	1		D		
38	514-25108-200	SCREW,SET	2		D		
39	991-01060-013	NUT,6	1		B		
40	894-01401-201	RECEIVER,OUTER	2		B		

* Indicates the part is included in a kit or assembly and is not available individually. Q=Quan. used
C=Interchangeability S=Stocking code: A-Fast moving B=Med. fast C=Med. move D=Slow move
E=N.L.A. F=Superseded or replaced by a new part

FIG.4 CLUTCH CASE

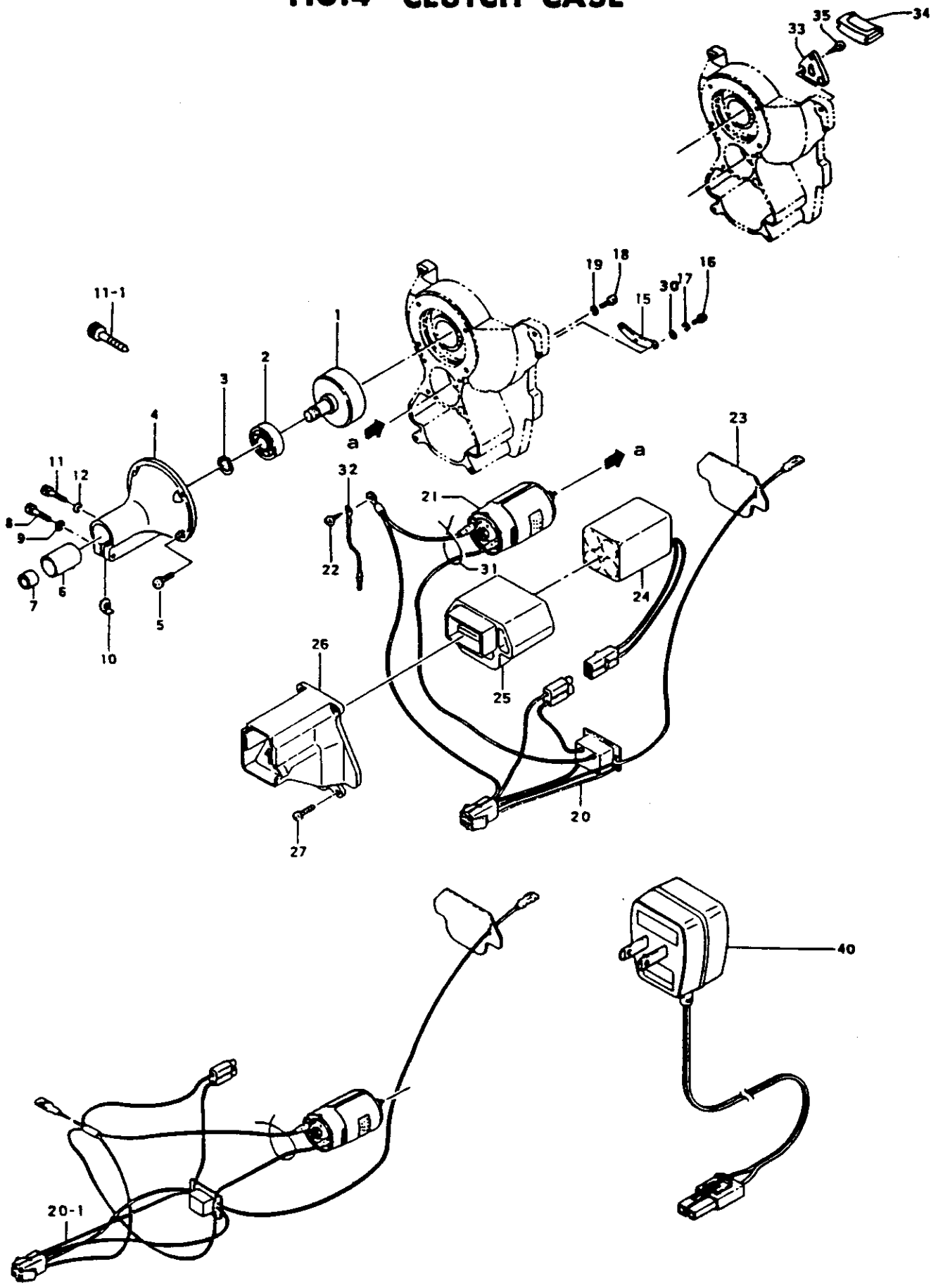

FIGURE 4

AST-5000 PARTS LISTING

REF.	PART NO.	PART DESCRIPTION	Q	C	S	SERIAL NO.	REMARKS
1	289-0635A-800	SHAFT,CLUTCH	1		D	~K259750	
1	289-00025-80	DRUM,CLUTCH	1		C	K259751~	
2	999-61620-101	BEARING,BALL #6201ZZ	1		B		
3	993-50012-002	RING,STOP,C-12 EX	1		A	K259751~	
4	331-0634F-201	CASE,CLUTCH	1		C	~H253160	
4	331-0636J-22	CASE,CLUTCH	1		D	H253161~	
5	994-14050-162	SCREW,S,5X16	4		B		
6	599-0635A-200	CUSHION	1		D	H253161~	
7	342-37711-200	COLLAR,6	1		C		
8	990-51050-203	BOLT,HEX.HOLE,5X20	1		C	~H253160	
8	990-51050-253	BOLT,HEX,5X25	1		B	H253161~	
9	992-10050-062	WASHER,S,5	1		D		
10	249-0630G-201	SPACER	1		C		
11	990-51050-153	BOLT,HEX.HOLE,5X15	1		C	H253161~	
11-1	380-0635D-200	BOLT,SPECIAL	1		C	K259751~	
12	992-10050-062	WASHER,S,5	1		D		
15	670-37600-201	RECEIVER,SHAFT	1		D	H253161~	
16	990-11040-121	SCREW,4X12	2		C		
17	992-10040-012	WASHER,S,4	2		B		
18	990-51030-103	BOLT,HEX.HOLE 3X10	2		C	~J065551	
18	990-54030-085	SCREW,HEX,3X8	2		C	J065552~	
19	992-10030-012	WASHER,S.,3	2		C		
20	655-37651-800	HARNESS,WIRE	1		C	~J065551	
20	655-37651-81	HARNESS,WIRE	1		D	J065552~	
21	306-0634F-800	MOTOR	1		D		
22	994-14040-081	SCREW,4X8	1		D		
22	990-72045-164	SCREW,TAPPING,4.5X16	1		C		
23	599-0634F-200	CUSHION	1		C		
24	BP-5000	BATTERY,ASS'Y	1		B		
25	152-0634F-200	PROTECTOR,BATTERY	1		D		
26	136-0634F-20	COVER,FAN CASE	1		D		
27	994-15040-122	SCREW,4X12/PS	4		C	~H253160	
27	990-72045-164	SCREW,TAPPING,4.5X16	4		C	H253161~	
30	992-00040-011	WASHER,4	2		B		
31	266-37600-200	CLAMP,WIRE	1		D		
32	274-0634F-800	CORD,EARTH	1		D		
33	670-37623-20	HOLDER,SHAFT	1		D		
34	129-0636T-20	COVER,SEAL	1		D		
35	990-72045-164	SCREW,TAPPING,4.5X16	2		C	K075477~	
40	BC-5000	CHARGER,BATTERY	1		A		

* Indicates the part is included in a kit or assembly and is not available individually. Q=Quan. used
C=Interchangeability S=Stocking code: A-Fast moving B=Med. fast C=Med. move D=Slow move
E=N.L.A. F=Superseded or replaced by a new part

FIG.5 HANDLE

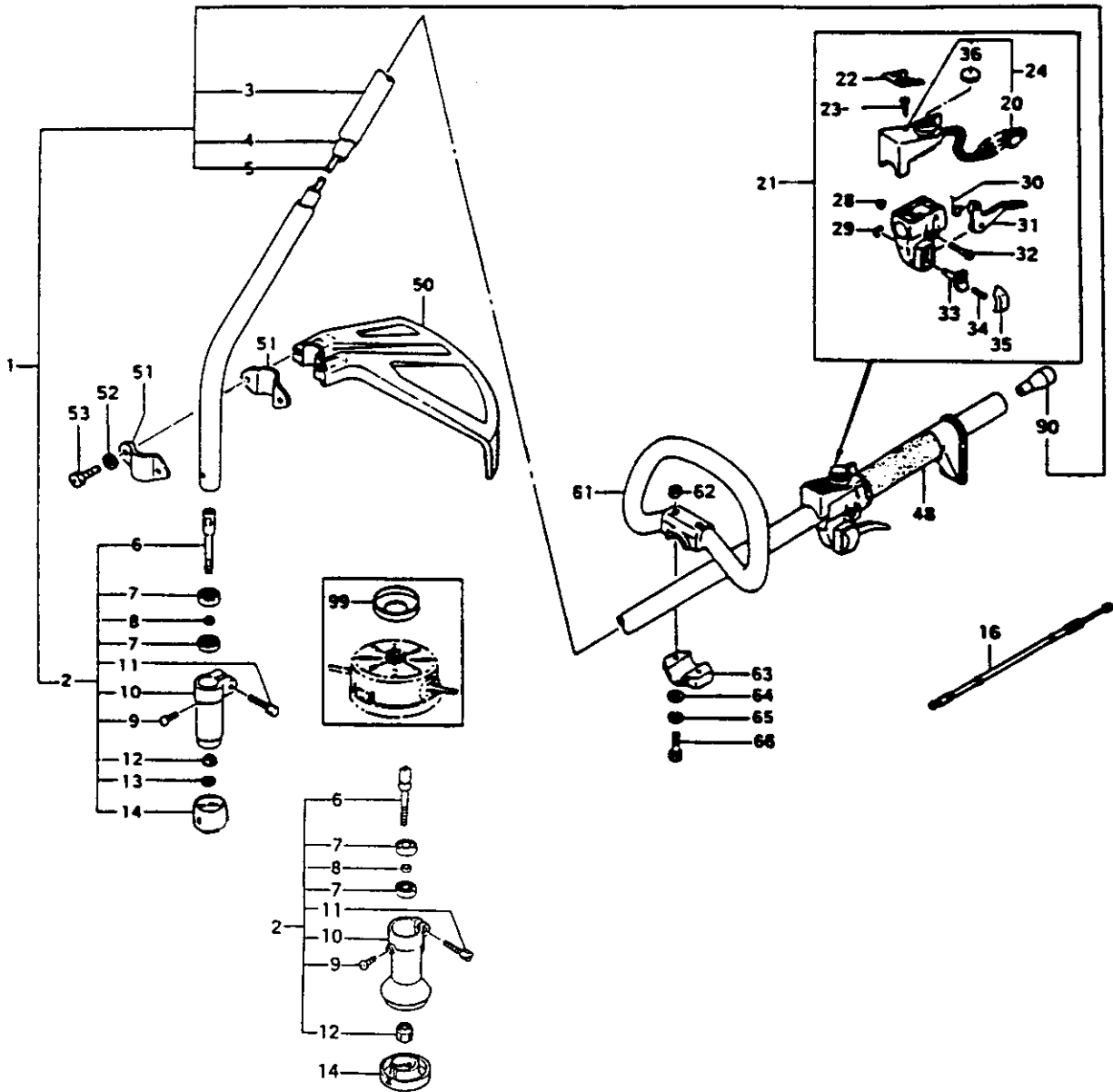

FIGURE 5

AST-5000 PARTS LISTING

REF.	PART NO.	PART DESCRIPTION	Q	C	S	SERIAL NO	REMARKS
1	343-37718-00	PIPE,DRIVE SHAFT SET	1		A		See PI-3036
2	299-37710-00	SET,GEAR CASE	1		C		Upgrade gear case
3	341-37715-20	CYLINDER	1		B		
4	350-37651-210	LINER,FLEXIBLE	1		B		
5	344-37651-21	SHAFT,FLEX	1		A		
6	304-37651-21	SHAFT,CUTTER	1		C		
7	999-61608-004	BEARING,BALL,608DD	2		B		
8	348-37651-20	COLLAR	1		D		
9	990-11050-101	SCREW,5X10	1		B		
10	300-37651-200	CASE,GEAR	1		D		
10	300-37710-20	CASE,GEAR	1		D		Upgraded type
11	994-25050-301	BOLT,PS,5X30	1		D		
12	760-37651-200	WASHER,SPECIAL	1		D		
12	315-37710-200	NUT,SPECIAL	1		C		
13	992-10080-012	WASHER,S,8	1		C		
14	310-37651-200	HOLDER,CUTTER	1		D		
14	310-37710-20	HOLDER,CUTTER	1		D		Fits upgraded gear case
16	885-0634F-800	WIRE,THROTTLE	1		C		
20	656-37600-200	CONNECTOR,MALE,4P	1		D		
21	870-37662-900	LEVER,THROTTLE ASS'Y	1		C		
22	169-37602-200	DECAL,OFF/ON	1		C		
23	993-42030-181	SCREW,TAPPING,3X18	2		C	~J195956	
23	993-42030-251	SCREW,TAP	2		D	J195957~	
24	156-37600-91	BUTTON,START	1		D		
28	991-86050-000	NUT,LOCK,5	1		D		
29	993-55060-001	RING,STOP,6	1		D		
30	832-37101-200	SPRING,RETURN	1		C		
31	880-37101-200	LEVER,THROTTLE	1		C		
32	994-31050-251	SCREW,S.,5X25	1		C		
33	853-37101-200	SHAFT,LOCK BUTTON	1		D		
34	958-37101-200	SPRING,LOCK,BUTTON	1		D		
35	956-37101-200	BUTTON,LOCK	1		D		
36	168-37623-200	COVER,BUTTON,STOP	1		C		
48	504-37700-200	GRIP,SHAFT	1		D		
50	441-37701-810	COVER,SAFETY	1		C		
51	442-37400-200	BRACKET,GUARD	2		C		
52	992-10060-012	WASHER,S,6	2		A		
53	990-23060-161	BOLT,6X16 PLUS	2		C		
61	500-37651-200	HANDLE	1		D		

* Indicates the part is included in a kit or assembly and is not available individually. Q=Quan. used
C=Interchangeability S=Stocking code: A-Fast moving B=Med. fast C=Med. move D=Slow move
E=N.L.A. F=Superseded or replaced by a new part

FIGURE 5 cont.

AST-5000 PARTS LISTING

REF.	PART NO.	PART DESCRIPTION	Q	C	S	SERIAL NO	REMARKS
62	991-01060-041	NUT,6	2		D		
63	506-37651-200	BRACKET,HANDLE,A	1		D		
64	992-01060-011	WASHER,6	2		C		
65	992-10060-012	WASHER,S,6	2		A		
66	990-23060-431	BOLT,P,6X43	2		C		
90	320-37651-200	SPACER	1		D		
99	307-37301-201	PROTECTOR,WINDING	1		D		

* Indicates the part is included in a kit or assembly and is not available individually. Q=Quan. used
 C=Interchangeability S=Stocking code: A-Fast moving B=Med. fast C=Med. move D=Slow move
 E=N.L.A. F=Superseded or replaced by a new part

FIG.6 TOOLS & NYLON HEAD

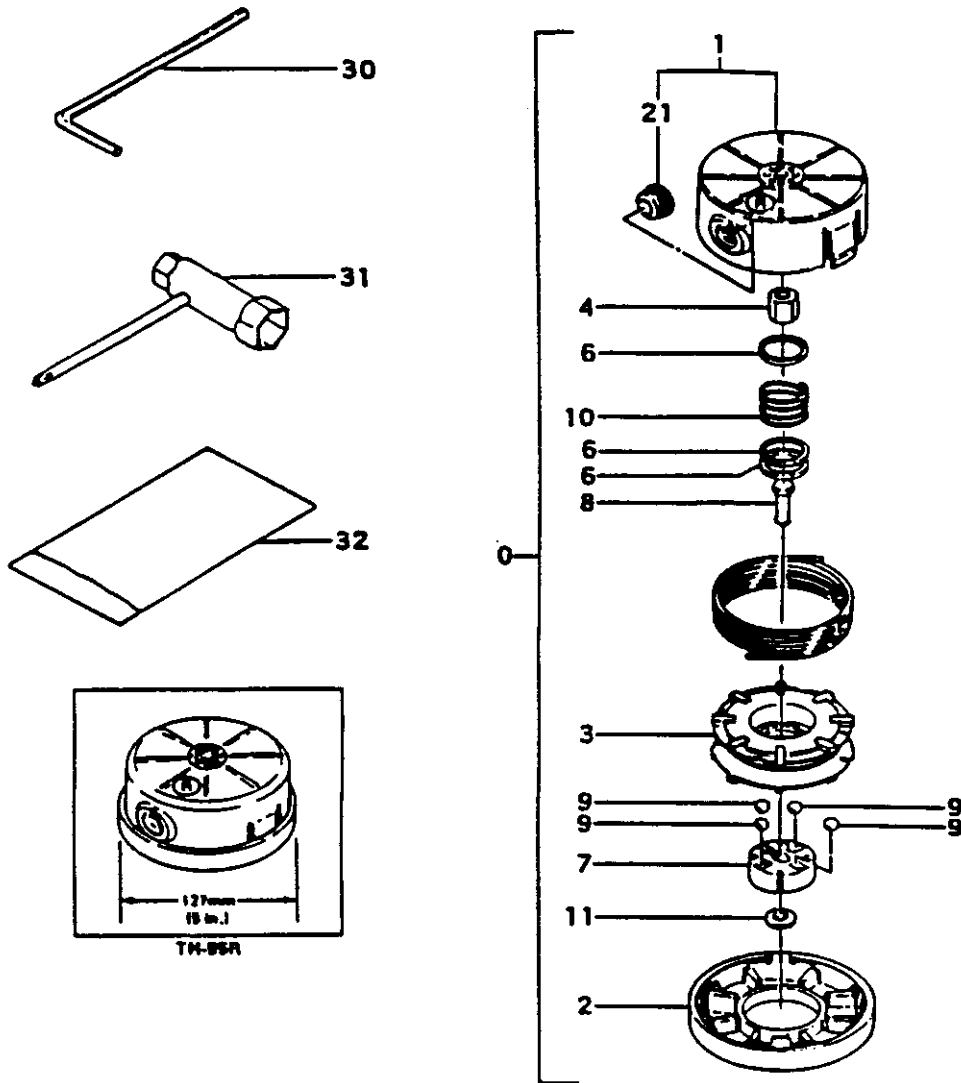

FIGURE 6

AST-5000 PARTS LISTING

REF.	PART NO.	PART DESCRIPTION	Q	C	S	SERIAL NO.	REMARKS
0	783-33071-91	HEAD,BRAIN,R	1		B		
1	786-33004-900	BODY,CUTTING,ASS'Y	1		A		
2	789-33004-21	CAP,BODY	1		B		
3	787-33004-202	REEL,(R S M X)	1		A		
4	315-33071-200	NUT,RH,OLIVE,8X1.25	1		B		
6	792-33004-200	WASHER,REEL	4		A		
7	790-33004-200	SLIDER,REEL	1		B		
8	791-33004-200	HOOK,REEL SLIDER	1		A		
9	673-35600-20	BALL,STEEL	4		B		
10	793-33071-200	SPRING,REEL,GREEN	1		A		
11	358-02103-200	WASHER,CLUTCH A	1		A		
21	788-33071-20	EYELET	2		A		
30	813-20000-200	WRENCH,HEX,4	1		C		
31	829-20000-80	SPANNER,COMBI,13X19	1		C		
32	948-39907-200	BAG,TOOL	1		C		

FIG.7 MARKS

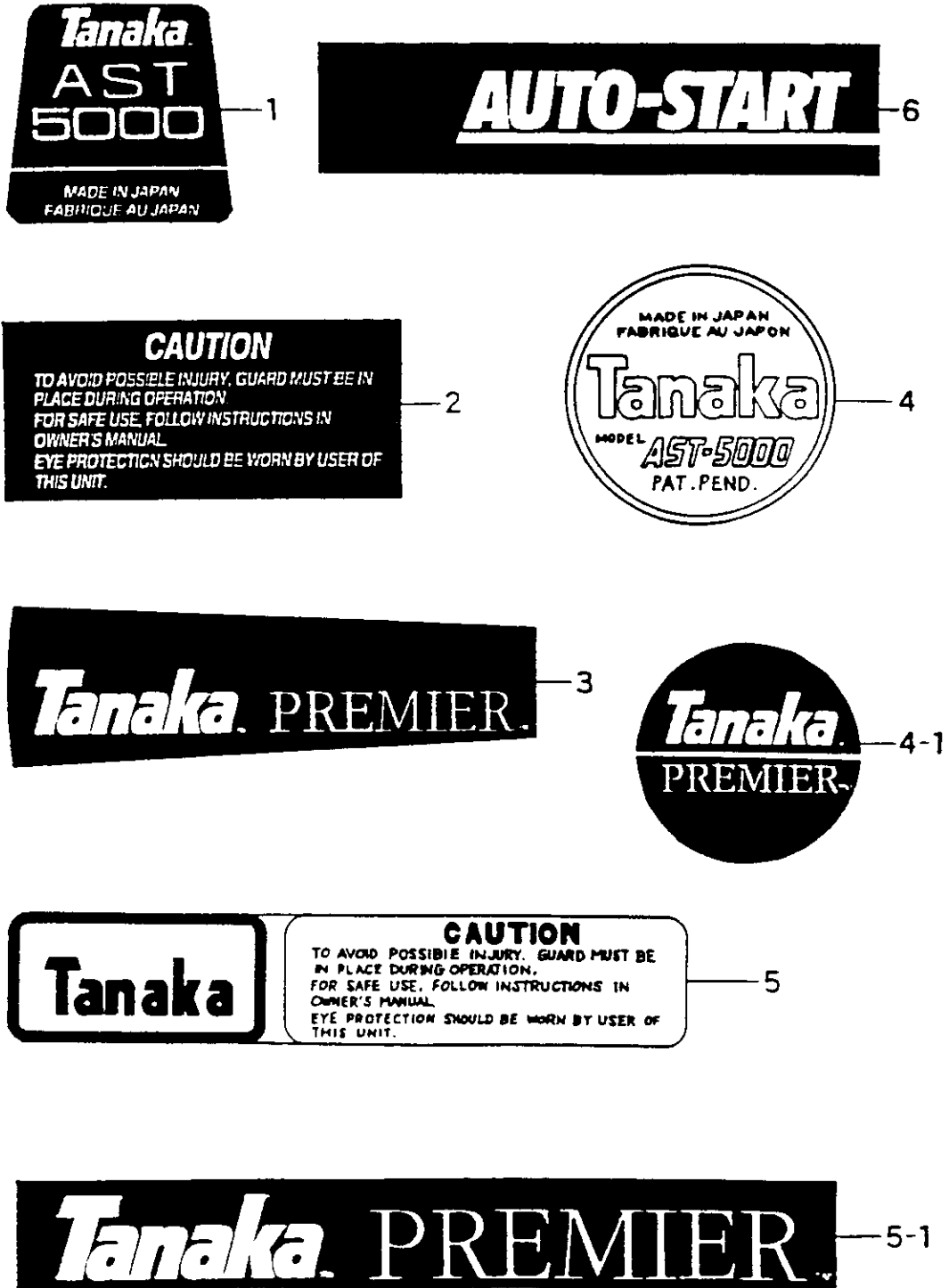
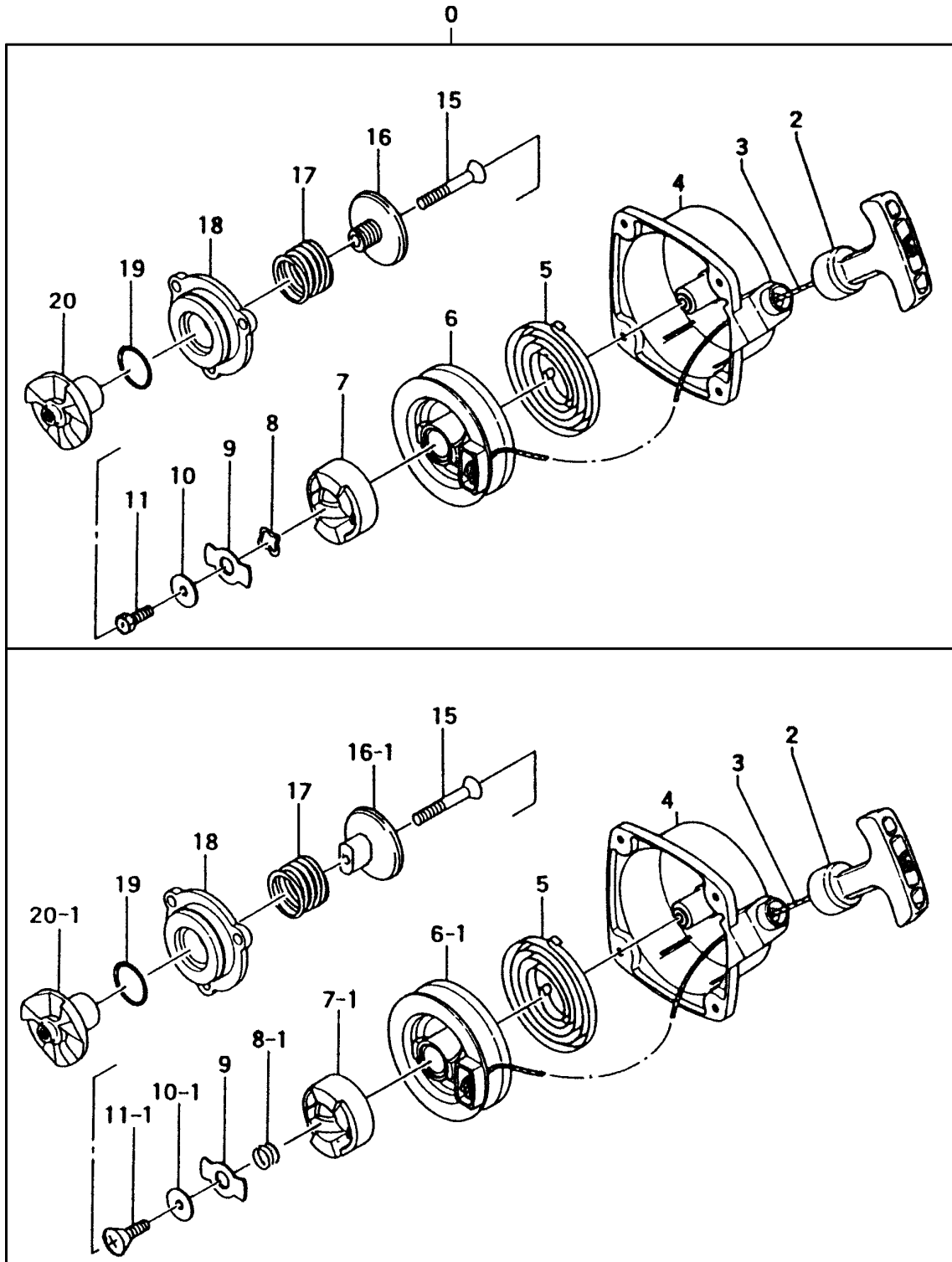

FIGURE 7

AST-5000 PARTS LISTING

REF.	PART NO.	PART DESCRIPTION	Q	C	S	SERIAL NO	REMARKS
1	906-37651-200	DECAL,AST-5000	1		D		
2	919-37701-200	DECAL	1		D		
3	933-37651-200	DECAL,SYMBOL,B	1		B		
4	906-0634F-200	DECAL,AST-5000	1		D		
4-1	950-37651-200	DECAL,PREMIER	1		D		
5	929-33006-201	DECAL,SYMBOL	1		D		
5-1	951-37651-200	DECAL,PREMIER	1		B		
6	918-37651-200	DECAL,AUTO START	1		E		



OPTIONAL RECOIL STARTER

ITEM	PART NUMBER	DESCRIPTION	QTY	COMMENTS
0	7560634F900	RECOIL STARTER KIT	1	
2	78500940200	HANDLE,STARTER ROPE	1	
3	78300940200	ROPE,STARTER	1	
4	7720634F800	BODY,RECOIL STARTER	1	
4-1	7720634F810	BODY,RECOIL STARTER	1	
5	7800634F200	SPRING,RECOIL	1	
6	77400940200	PULLEY,STARTER	1	
6-1	7740636T200	PULLEY,STARTER	1	
7	7880634F200	PAWL,STARTER	1	
7-1	7880636T200	PAWL,STARTER	1	
8	8010634F200	WASHER,PULLEY	1	
8-1	8010636T200	SPRING,STARTER PAWL	1	
9	8370634F200	PLATE,FRCITION	1	
10	8220634F200	SHIM,STARTER PULLEY	1	
10-1	8220636T200	SHIM,STARTER PULLEY	1	
11	83905015200	BOLT,SET	1	
11-1	8390636T200	BOLT,SET	1	
15	99012050281	SCREW,FH 5X28	1	
16	7980634F200	PULLEY	1	
16-1	7980634F210	PULLEY	1	
17	7610634F210	SPRING	1	
18	7710634F201	HOLDER,PULLEY	1	
19	99967014000	O-RING	1	
20	7730634F201	PULLEY	1	
20-1	7730634F210	PULLEY	1	