

INSTALLATION AND ASSEMBLY INSTRUCTIONS

FAN ASSEMBLY AND DRIVE KITS

For use on the following models:

968999151-152-157-158-159-160-161-162-163-164-165-166-168-169-170-172-157-168-169-170-171-173-175-180-181-182-183-184-185-186-187-188-189-201-202 and
ZKWQL48170-ZKWQL48190-ZKWQL48171-ZKWQL48191-ZKWQL42171-ZKWQL42172-
ZKWQL48172-ZKWQL48192-ZVKH52230-ZVKW52250-ZVKW61230-ZVKHL61230-
ZVKH61250-ZVKW61250-ZVKH61270-ZVKE61260

Safety Instruction (Read Carefully):

Do not operate fan with hose removed.

Keep all hose clamps and mounting fasteners tight.

Do not operate without guards in place.

Do not attempt to remove fan assembly or clear blockage unless engine is off and ignition key removed.

If fan assembly is removed, replace original sheave, belt shield, and discharge chute before operating mower.

Install the fan assembly, hose support, and hose as follows:

1. Remove the discharge chute.
2. Remove the right hand belt shield.
3. Remove the deck belt from the right spindle assembly sheave.
4. Remove this sheave but keep the ¼" square key and the two washers at hand for reinstallation.
5. Install the Stepped Sheave and spacer/key retainer included in the kit using the original key and washers but substituting the original 7/16" HCS with the longer version provided. An application of anti-seize is recommended.
6. Reinstall the deck belt.
7. The 5/8" hole toward the rear of the ¼" thick discharge chute mounting bar at the right end of the deck may be distorted from forming or loaded with paint. Drill out or fill this hole until it will accept a 5/8" bolt or piece of bar stock. Keep the fit close.
8. If any weld beads or the edge of the deck top project past the right end surface of the deck, these must be ground back to allow the fan assembly to fit up flush to the end of the deck.
9. Remove the 3/8" fastener, nut, and clamp from the inside front corner of the fan assembly.
10. Remove the sheave floor to expose the fan assembly belt sheave from below.
11. Loosen the nut retaining the belt guide/retainer, install the belt from the Drive Kit, retighten the nut, verify the belt clears the guide, and reinstall the sheave floor.
12. Rest the fan assembly onto the deck end and slide the pilot thru the 5/8" hole previously mentioned so that fan assembly is supported by the pilot and the ¼" stop block welded under the clamp at the front of the fan assembly.
Note: It may be necessary to swing the idler pulley away from the assembly mounting face to clear the chute mounting bar and the discharge chute mounting tab on the deck.
13. Reinstall the clamp at the front of the assembly so that the tab at the lower end of the clamp passes thru the rectangular slot at the right front corner of the mower deck, but leave the fastener loose to ease belt installation.
14. Rotate the belt idler as far forward as possible and install the belt over the top groove of the new deck sheave.
15. Tighten the clamp fastener.
16. Using a scribe or other small sharp object, transfer the mounting hole location at the rear edge of the fan assembly onto the mating vertical surface at the right rear of the mower deck and drill thru with a 25/64" drill.
17. Install the new belt shield.
18. Install the tube support to the main collection assembly using the 3/8" fastener provided, positioning so that the tube is 2" to 3" away from the tire.
19. Install the 7" tube to the fan assembly and the container input port using the hose clamps provided.
20. Clamp the tube to the tube support.

FAN ASSEMBLY

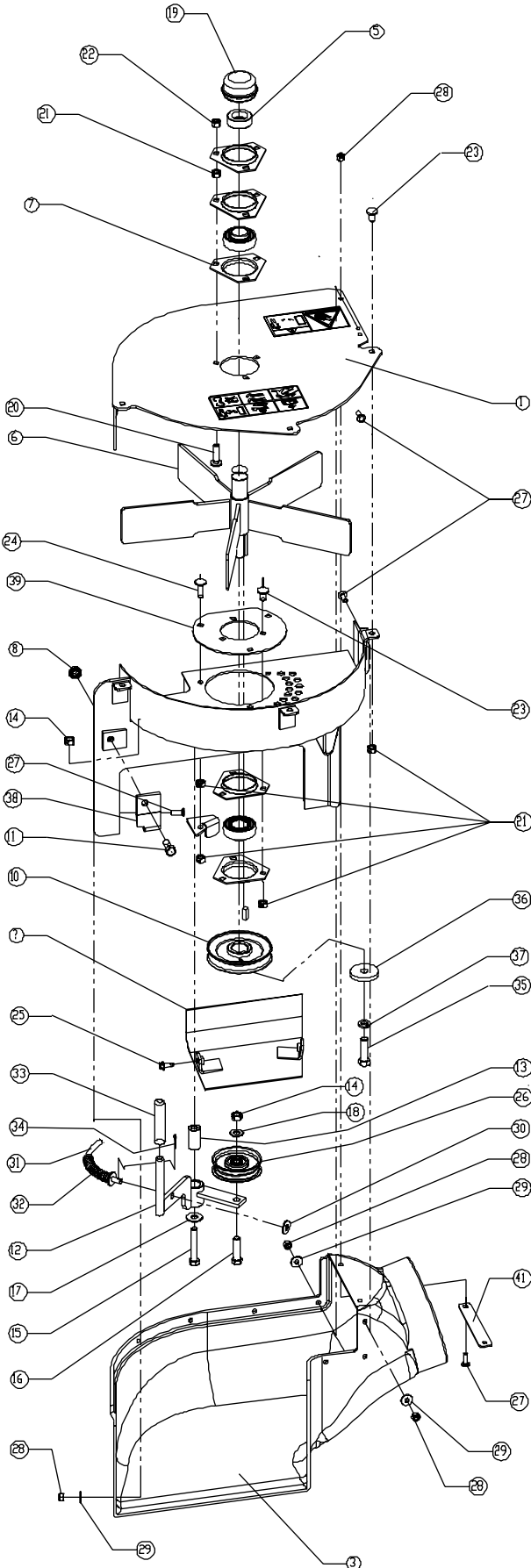

FAN ASSEMBLY INSTRUCTIONS:

1. CRADLE A BEARING W/ INNER RACE EXTENSION DOWN BETWEEN TWO FLANGETTES AND ATTACH TO BEARING PLATE AS SHOWN LEAVING FASTENERS SLIGHTLY LOOSE
 2. APPLY ANTI-SIEZE TO THE FAN SHAFT AND KEYWAY AND SLIDE INTO THE BEARING
 3. INSTALL THE KEY AND PULLEY (HUB DOWN) ON TO THE FAN WLDMT SHAFT WITH ITEMS 35, 36, & 37 AS SHOWN
 4. ATTACH THIS ASSEMBLY TO FAN FLOOR AS SHOWN AND TIGHTEN THESE FASTENERS
 5. INSTALL IDLER AND GRIP TO IDLER ARM WLDMT AS SHOWN
 6. INSTALL THIS ASM WITH SLEEVE BUSHING TO THE UPPER HSG WLDMT
 7. SLIDE SPRING ONTO SPRING ROD AND INSTALL ONTO IDLER ARM & INTO HOUSING SLOT WITH WASHER AND COTTER PIN AS SHOWN
 8. ATTACH LOWER HOUSING TO UPPER HOUSING USING ITEM 41 INSIDE OUTLET AS SHOWN & SECURE THESE FASTENERS AFTER ALL ARE IN PLACE
 9. CRADLE THE OTHER BEARING W/ INNER RACE EXTENSION UP BETWEEN TWO FLANGETTES AND ATTACH TO FAN COVER WLDMT AS SHOWN LEAVING FASTENERS SLIGHTLY LOOSE
 10. INSTALL THIS ASSEMBLY TO THE UPPER & LOWER HSG ASM APPLYING A THIN BEAD OF SILICONE SEALER TO MATING SURFACES AROUND FAN & SECURE FASTENERS
- NOTE: IT IS IMPORTANT TO BEARING LIFE THAT THE FASTENERS THAT SECURE THE BEARINGS BE LEFT SLIGHTLY LOOSE TO THIS POINT**
11. EVENLY TIGHTEN ALL SIX FASTENERS SECURING THE BEARINGS
 12. ATTACH THE LOCKING COLLAR TO THE UPPER BEARING TIGHTEN ON THE BEARING CAM IN A CLOCKWISE DIRECTION AS SEEN FROM ABOVE & TIGHTEN THE SET SCREWS
 13. INSTALL ITEM 19 INTO REMAINING FLANGETTE USING THE PROPER INSTALLATION TOOL SO AS NOT TO DENT
 14. THIS ASSEMBLY SERVES AS SHIELD OVER SHAFT END - INSTALL AS SHOWN
 15. ATTACH REMAINING PARTS AS SHOWN

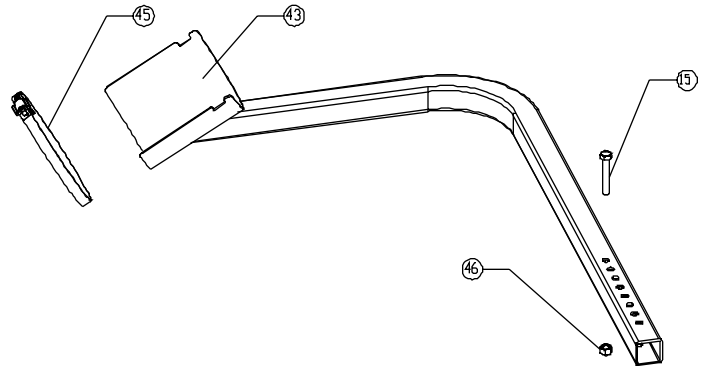
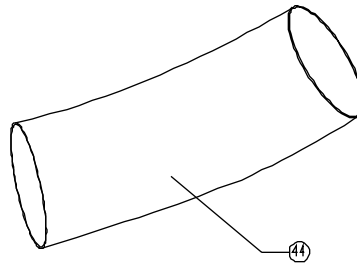

FAN ASSEMBLY

ITEM	PART NO.	QTY	DESCRIPTION
1	539106752	1	FAN COVER W/DECALS
2	539106693	1	UPPER HOUSING
3	539106706	1	LOWER HOUSING
4	539106786	2	BEARING W/O COLLAR
5	539106786	1	LOCKING COLLAR
6	539106707	1	FAN WLDMT.
7	539102691	5	FLANGETTE
8	539990613	1	NUT 3/8 FLANGE
9	539106711	1	SHEAVE FLOOR
10	539106713	1	SHEAVE, 4"
11	539990563	1	HCS 3/8 X 1.0
12	539106715	1	IDLER ARM
13	539101836	1	SLEEVE BUSHING
14	539990546	2	NUT 3/8 CTR. LOCK
15	539990629	2	HCS 3/8 X 2.25
16	53999065	1	HCS 3/8 X 1.50
17	539990517	1	WASHER 3/8 FLAT
18	539990122	1	WASHER 3/8 SAE
19	539102535	1	GREASE CAP
20	539100472	3	RHSNB 5/16 X 1.25
21	539990184	13	NUT 5/16 CTR. LOCK
22	539990717	3	NUT 5/16 NYLOC
23	539990799	8	RHSNB 5/16 X .625 SHORT NECK
24	539990208	1	RHSNB 5/16 X 1.00
25	539990362	2	SCREW 1/4 X .625 SELF TAP
26	539106721	1	IDLER
27	539990074	16	RHSNB 1/4 X .75 SHORT NECK
28	539976978	16	NUT 1/4 NYLOC
29	539990598	14	WASHER 1/4 FLAT
30	539990692	1	WASHER 5/16 FLAT
31	539106801	1	SPRING ROD
32	539106720	1	SPRING
33	539101050	1	VINYL GRIP
34	539990037	1	COTTER PIN 3/32 X .750
35	539100141	1	HCS 7/16F X 1.5
36	539106504	1	HEAVY WASHER
37	539990247	1	WASHER 7/16 LOCK
38	539106810	1	CLAMP
39	539106809	1	BEARING PLATE
40	539106811	1	BELT GUIDE
41	539106812	1	BACKING
42	539102067	1	KEY 1/4 X .75 SQ.
43	539106751	1	SUPPORT
44	539106748	1	HOSE
45	53997076	3	HOSE CLAMP
46	539976979	1	NUT 3/8 NYLOC

DRIVE KIT ASSEMBLY

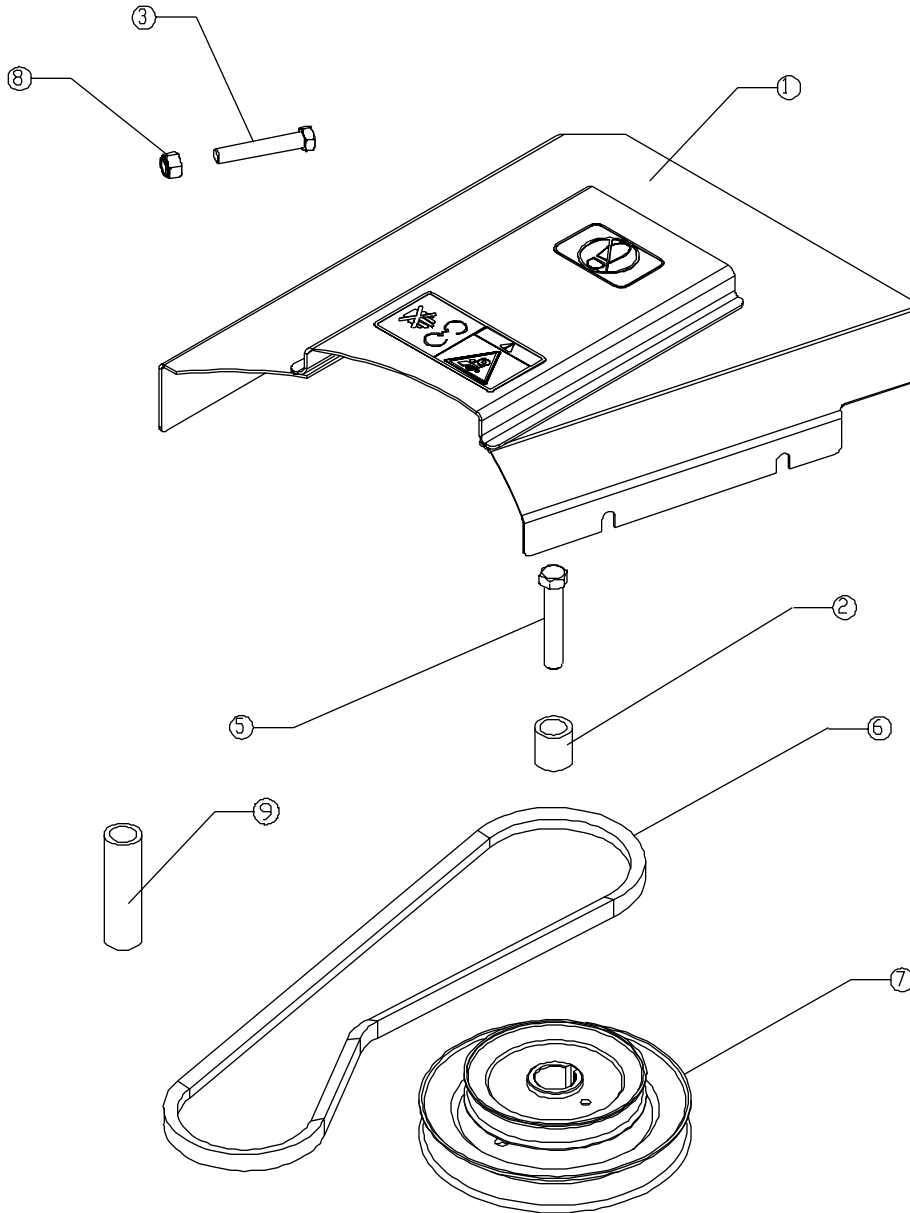

ITEM	PART NO.	QTY	DESCRIPTION
1	539106778	1	42 SHIELD W/DECALS
	539106779	1	48 SHIELD W/DECALS
	539106780	1	52 SHIELD W/DECALS
	539106781	1	61 SHIELD W/DECALS
2	539106739	1	SPACER
3	539990629	1	HCS 3/8 X 2.25 USED ON 48"/52"/61"
	539976941	1	HCS 3/8 X 1.25 (42" ONLY)
5	539991120	1	HCS 7/16 X 2.5
6	539106723	1	BELT-42
	539106724	1	BELT-48
	539106725	1	BELT-52
	539106726	1	BELT-61
7	539106744	1	STACKED SHEAVE 42-48
	539106745	1	STACKED SHEAVE 52
	539106746	1	STACKED SHEAVE 61
8	539976979	1	NUT 3/8 NYLOC
9	539106787	2	STOP - USED ON 42" & 48" ONLY