

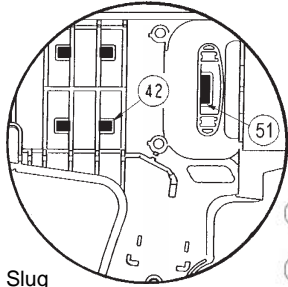

# SERVICE PARTS LIST

**BULLETIN NO.**  
**55-26-1800**

SPECIFY CATALOG NO. AND SERIAL NO. WHEN ORDERING PARTS		REVISED BULLETIN	DATE
<b>CORDLESS 13mm IMPACT WRENCH</b>			Mar. 2010
CATALOG NO. <b>9079-50</b>	STARTING SERIAL NO. <b>241A</b>	WIRING INSTRUCTION <b>58-01-1830</b>	



Slug placement is for both handle halves.

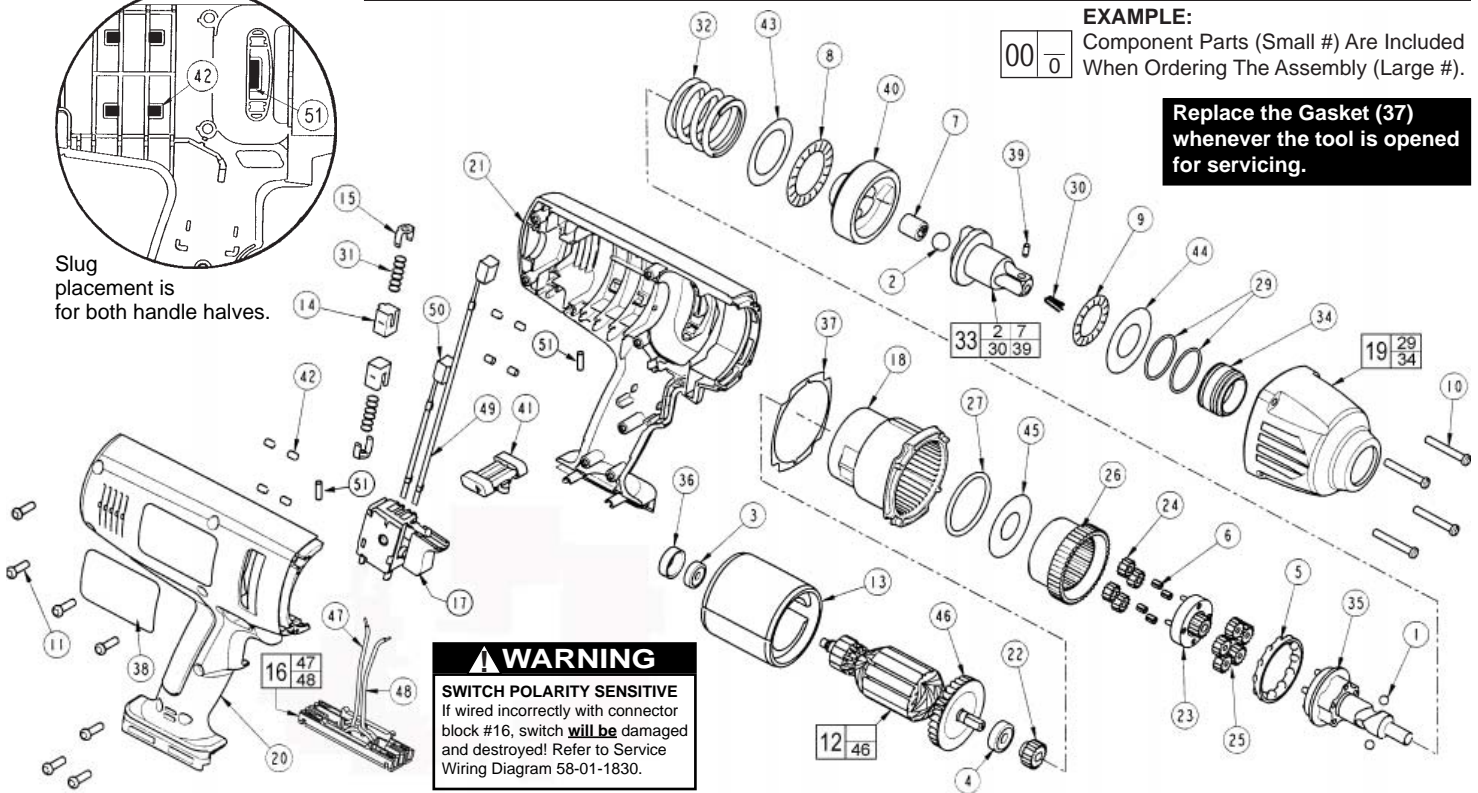

**Replace the Gasket (37) whenever the tool is opened for servicing.**

**WARNING**  
**SWITCH POLARITY SENSITIVE**  
If wired incorrectly with connector block #16, switch **will be** damaged and destroyed! Refer to Service Wiring Diagram 58-01-1830.

**EXAMPLE:**  
Component Parts (Small #) Are Included When Ordering The Assembly (Large #).

00 / 0

FIG.	PART NO.	DESCRIPTION OF PART	NO.REQ.
1	02-02-0250	1/4" Ball	(2)
2	-----	1/2" Ball	(1)
3	02-04-0645	Ball Bearing	(1)
4	02-04-0852	Ball Bearing	(1)
5	02-40-0050	Angular Contact Bearing	(1)
6	02-50-3260	Unit Cage Bearing	(4)
7	-----	Drawn Cup Bearing	(1)
8	02-80-0200	Thrust Bearing	(1)
9	02-80-3256	Thrust Bearing	(1)
10	05-88-5988	K50 x 35mm Screw	(4)
11	06-95-6290	M5 x 2.24 x 18 Plastite Screw	(7)
12	16-01-2100	Armature	(1)
13	18-01-2120	Field	(1)
14	22-20-0425	Brush Tube	(2)
15	22-32-0420	Brush Spring Clip	(2)
16	22-56-0279	Connector Block Assembly	(1)
17	23-66-0135	Switch	(1)
18	28-14-0175	Gearcase	(1)
19	14-38-0100	Front Housing Assembly	(1)
20	31-44-2186	Right Handle	(1)
21	31-44-2191	Left Handle	(1)
22	32-60-0170	Sun Gear	(1)
23	32-60-0185	Sun Gear	(1)
24	32-62-0210	Planet Gear	(4)
25	32-62-0215	Planet Gear	(5)
26	32-65-0005	Ring Gear	(1)
27	34-40-0070	O-Ring	(1)
29	-----	O-Ring	(2)
30	40-50-8320	Detent Spring	(1)
31	40-50-9079	Spring	(2)
32	40-50-0241	Spring	(1)
33	14-73-0145	Anvil Assembly	(1)
34	-----	Bushing	(1)
35	14-73-0300	Cam Shaft Assembly	(1)
36	42-96-0015	Bearing Cup	(1)
37	43-44-0991	Gasket	(1)
38	12-20-3400	Service Nameplate Kit	(1)
39	44-60-1170	Detent Pin	(1)
40	44-82-0205	Ram	(1)
41	45-24-0510	Reversing Shuttle	(1)
42	45-30-0021	Rubber Slug	(8)
43	45-88-0535	Washer	(1)

FIG.	PART NO.	DESCRIPTION OF PART	NO.REQ.
44	45-88-1575	Washer	(1)
45	45-88-3250	Washer	(1)
46	22-84-0375	Fan	(1)
47	-----	Leadwire Assembly-Black	(1)
48	-----	Leadwire Assembly-Red	(1)
49	22-18-2080	Brush Assembly-Red	(1)
50	22-18-1980	Brush Assembly-Black	(1)
51	45-30-0025	Rubber Slug	(2)

FIG.	NOTES:
3	Orient bearing seal (black side) toward the commutator.
10	Torque to 45-50 in./lbs.
11	Torque to 25-30 in./lbs.
49,50	At the time of brush replacement, the tool should be relubricated with Type "Z" Grease, No.49-08-7655.
FIG. 19,26,34, 35,40	<b>LUBRICATION (Type "Z" Grease, No.49-08-7655):</b> Lightly coat with grease the Ring Gear (26) and the Camshaft Planet Carrier bearing races (35). Lightly coat with grease the back bearing surface of the Ram (40) and the I.D. of the Front Housing Bushing (34).
7,33	Place a dab of grease in the Needle Bearing (7) inside the Anvil (33).
23,24,25,35	Fill with grease the center of the five Planet Gears (25) on the Camshaft Assembly (35). Fill the center of the four Planet Gears (24) on the Sun Gear (23).
40	Place approximately 1/4 oz. of grease in the front cavity of the Ram.
35	Place approximately 1/4 oz. grease on the Camshaft (35) inside the Spring (32).