

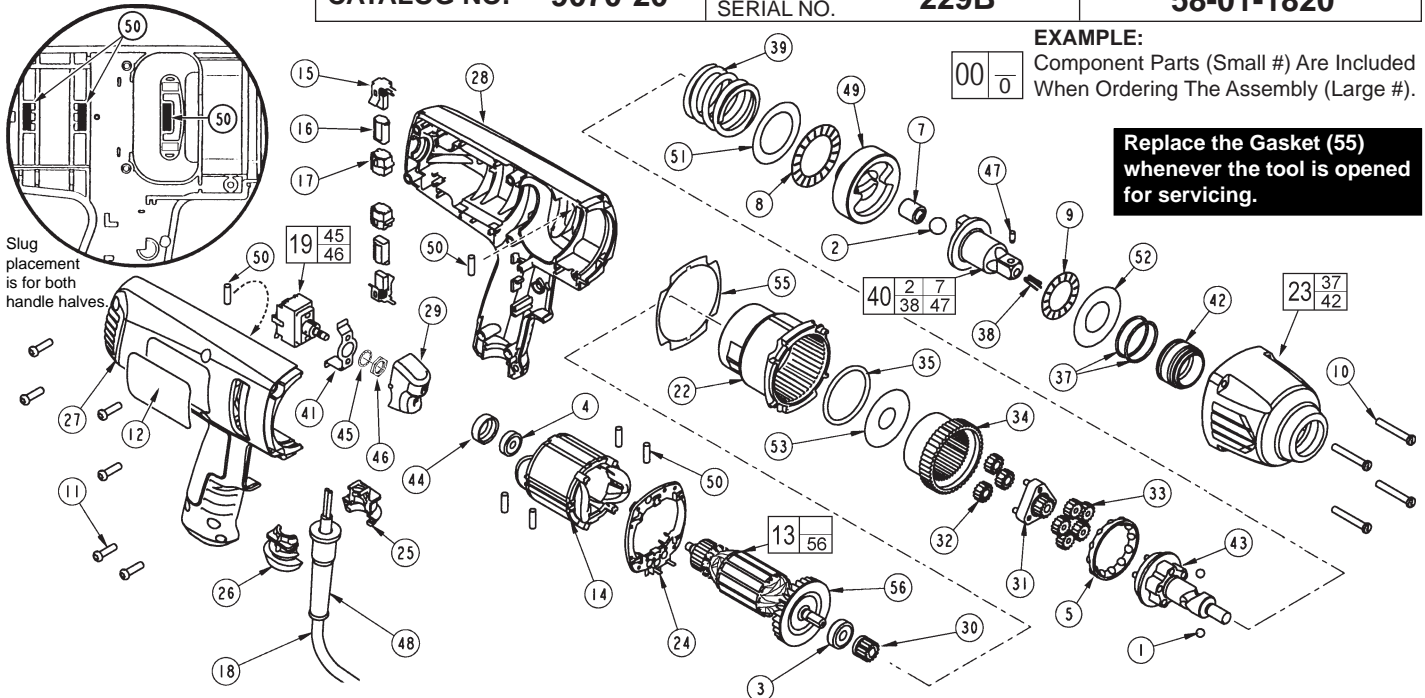

SERVICE PARTS LIST

BULLETIN NO.
54-26-1701

SPECIFY CATALOG NO. AND SERIAL NO. WHEN ORDERING PARTS		REVISED BULLETIN 54-26-1700	DATE Mar. 2008
1/2" D.I. IMPACT WRENCH			
CATALOG NO.	9070-20	STARTING SERIAL NO.	229B
		WIRING INSTRUCTION 58-01-1820	



EXAMPLE:
Component Parts (Small #) Are Included
When Ordering The Assembly (Large #).

**Replace the Gasket (55)
whenever the tool is opened
for servicing.**

FIG.	PART NO.	DESCRIPTION OF PART	NO.REQ.
	02-02-0250	1/4" Ball	(2)
2	-----	1/2" Ball	(1)
3	02-04-0852	Ball Bearing	(1)
4	02-04-0645	Ball Bearing	(1)
5	02-40-0050	Angular Contact Bearing	(1)
7	-----	Drawn Cup Bearing	(1)
8	02-80-0200	Thrust Bearing	(1)
9	02-80-3256	Thrust Bearing	(1)
10	05-88-5988	K50 x 35mm Screw	(4)
11	06-95-6290	M5 x 2.24 x 18 Plastite Screw	(6)
12	12-20-9070	Service Nameplate	(1)
★ 13	16-10-2275	Armature	(1)
14	18-07-2275	Field	(1)
15	22-18-0040	Brush Assembly	(2)
16	22-20-0110	Brush Tube	(2)
17	22-20-0465	Brush Tube Holder	(2)
18	22-64-0970	Cord	(1)
19	23-66-1305	Switch	(1)
22	28-14-0175	Gearcase	(1)
23	14-38-0100	Front Housing Assembly	(1)
24	31-15-2045	Field Connector	(1)
★ 25	31-17-0261	Cord Clamp	(1)
★ 26	31-17-0271	Cord Clamp	(1)
27	31-44-2176	Right Handle	(1)
28	31-44-2181	Left Handle	(1)
29	31-92-0060	Rocker Trigger	(1)
30	32-60-0150	Sun Gear	(1)
31	32-60-0175	Sun Gear	(1)
★ 32	32-62-0215	Planet Gear	(3)
33	32-62-0215	Planet Gear	(5)
34	32-65-0005	Ring Gear	(1)
35	34-40-0070	O-Ring	(1)
37	-----	O-Ring	(2)
38	40-50-8320	Detent Spring	(1)
39	40-50-0241	Spring	(1)
40	14-73-0145	Anvil Assembly	(1)
41	42-36-0275	Switch Bracket	(1)
42	-----	Bushing	(1)
43	14-73-0300	Cam Shaft Assembly	(1)
44	42-96-0015	Bearing Cup	(1)
45	-----	Supplied with Switch	(1)
46	-----	Supplied with Switch	(1)

FIG.	PART NO.	DESCRIPTION OF PART	NO.REQ.
47	44-60-1170	Detent Pin	(1)
48	44-76-0210	Cord Protector	(1)
49	44-82-0205	Ram	(1)
50	45-30-0025	Rubber Slug	(6)
51	45-88-0535	Washer	(1)
52	45-88-1575	Washer	(1)
★ 53	45-88-3250	Washer	(1)
55	43-44-0991	Gasket	(1)
56	22-84-0375	Fan	(1)

- FIG. 4** NOTES:
Orient bearing seal (black side) toward the commutator.
- 10 Torque to 45-50 in./lbs.
- 11 Torque to 25-30 in./lbs.
- 16 At the time of brush replacement, the tool should be relubricated with Type "Z" Grease, No.49-08-7655.
- FIG. 23,34,42, 43,49** **LUBRICATION (Type "Z" Grease, No.49-08-7655):**
Lightly coat with grease the Ring Gear (34) and the bearing races of the Camshaft Planet Carrier (43), the back bearing surface of the Ram (49) and the I.D. the Front Housing Bushing (42).
- 7,40 Place a dab of grease in the Needle Bearing (7) inside the Anvil (40).
- 31,32,33,43 Fill with grease the center of the five Planet Gears (33) on the Camshaft Assembly (43). Fill the center of the three Planet Gears (32) on the Sun Gear (31).
- 49 Place approximately 1/2 oz. of grease in the front cavity of the Ram.
- 43 Place approximately 1/2 oz. grease on the Camshaft (43) inside the Spring (39).