



SERVICE PARTS LIST

BULLETIN NO.
54-26-1552

SPECIFY CATALOG NO. AND SERIAL NO. WHEN ORDERING PARTS		REVISED BULLETIN	DATE
1/2" IMPACT WRENCH		54-26-1551	Feb.'88
CATALOG NO. 9065	STARTING SERIAL NO. 656-37000	WIRING INSTRUCTION 58-01-0528	

EXAMPLE:

00 0 Component Parts (Small #) Are Included When Ordering The Assembly (Large #).

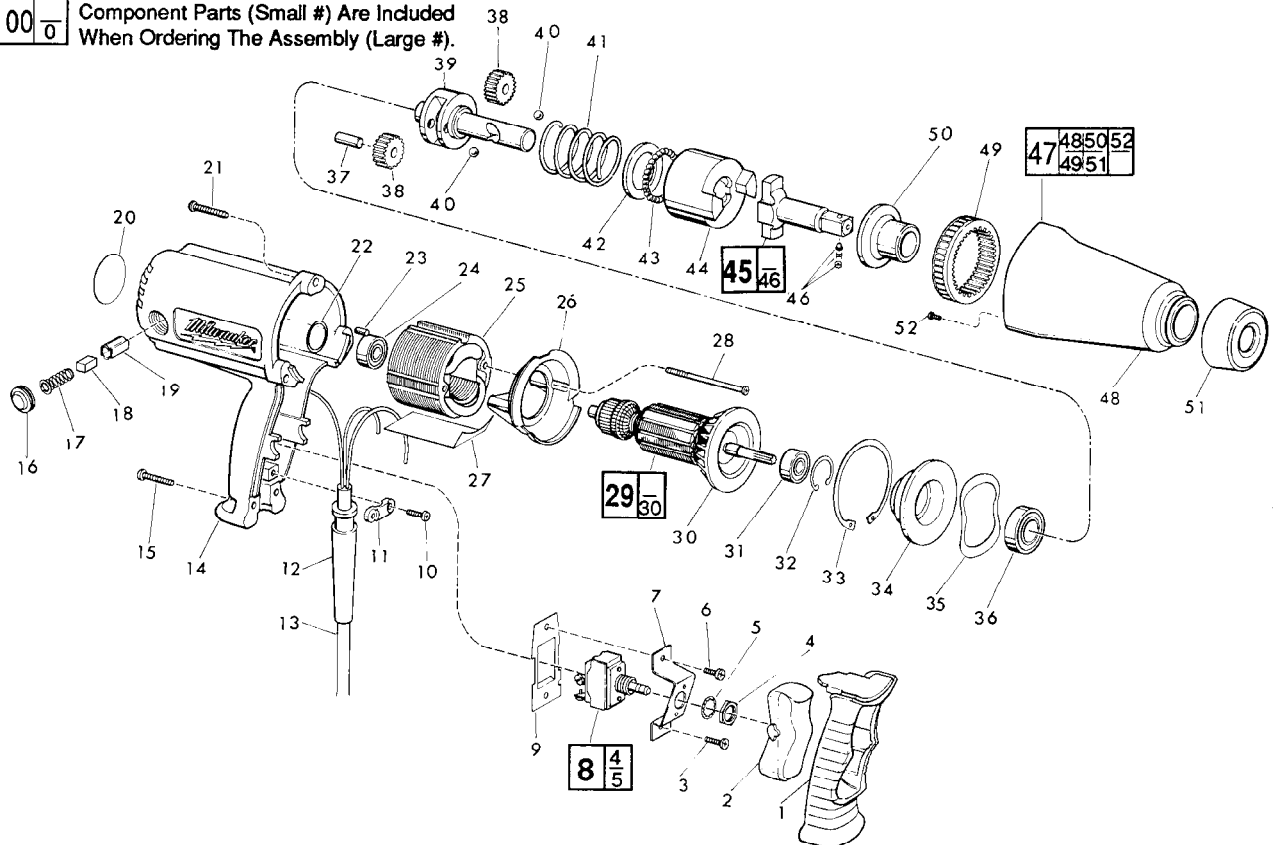

FIG.	PART NO.	DESCRIPTION OF PART	NO. REQ.
1	31-44-1270	Handle Half	(1)
2	31-92-0240	Trigger	(1)
★3	06-82-7270	8-16 x 5/8" Lg. Plastite Torx Screw	(1)
4	-----	Supplied with switch	(1)
5	-----	Supplied with switch	(1)
★6	06-82-7251	8-16 x 3/8" Lg. Pan Hd. Plastite Torx Screw	(1)
7	42-36-1460	Switch Bracket	(1)
8	23-66-1310	Switch	(1)
9	23-16-1350	Switch Insulator	(1)
★10	06-82-7270	8-16 x 5/8" Lg. Plastite Torx Screw	(2)
11	31-17-0155	Cord Clamp	(1)
12	44-76-0120	Cord Protector	(1)
13	22-64-0155	Cord Set	(1)
14	31-50-0186	Motor Housing	(1)
★15	06-82-7299	8-16 x 7/8" Lg. Plastite Torx Screw	(2)
16	23-44-0125	Brush Retaining Screw	(2)
17	23-52-0220	Brush Spring Assembly	(2)
18	22-16-0300	Carbon Brush	(2)
19	22-20-0530	Brush Tube	(2)
20	12-99-0176	Service Nameplate	(1)
	12-90-0196	Service Nameplate - Canada	
★21	06-82-5362	8-32 x 1" Lg. Pan Hd. Tapitite Torx Screw	(3)
22	34-40-1125	O-Ring	(1)
23	45-30-0070	Ball Bearing Retaining Slug	(1)
24	02-04-0845	Ball Bearing	(1)
25	18-10-0080	120 V. Field	(1)
26	42-14-0270	Baffle	(1)
27	23-16-1390	Paper Barrier	(1)
★28	06-82-7392	7-18 x 2" Fil. Hd. Plastite Torx Screw	(2)
29	16-10-0430	120 V. Armature	(1)
30	22-84-0650	Fan Assembly	(1)
31	02-04-0845	Ball Bearing	(1)
32	34-80-0200	Internal Retaining Ring	(1)
33	34-80-0250	Internal Retaining Ring	(1)
34	28-72-6510	Bearing Plate	(1)
35	40-50-7950	Wave Spring	(1)

FIG.	PART NO.	DESCRIPTION OF PART	NO. REQ.
36	02-04-1515	Ball Bearing	(1)
37	44-96-0100	Roller	(2)
38	32-62-0055	Planet Gear	(2)
★39	42-50-0230	Cam	(1)
40	02-02-0250	1/4" Steel Ball	(2)
41	40-50-4915	Hammer Spring	(1)
42	45-88-0385	Thrust Washer	(1)
43	02-02-0150	5/32" Steel Ball	(26)
★44	44-82-0121	Ram	(1)
45	42-06-0125	Anvil Assembly	(1)
46	44-60-0775	Detent Assy. (Spring, Pin & Plug)	(1)
★47	14-38-0412	Front Housing Assembly	(1)
48	-----	Front Housing	(1)
49	-----	Ring Gear	(1)
50	-----	Bushing	(1)
51	42-38-0211	Boot	(1)
★52	06-82-5280	6-32 x 3/8" Lg. Ground Screw	(1)
	06-97-1800	Switch Terminal Lockwasher	(4)
	12-98-7260	Caution Label	(1)

FIG. NOTES:

24,31 Seal Towards Armature
28 Torque to 14-17 In./Lbs.

FIG. LUBRICATION

38 1/4 Oz. Type "U" Grease, 49-08-0150, Around Inside Of Hub of Both Planet Gears Before Assembling to Cam.
39 A Dab Of Type "U" Grease On Each "V" Groove. Apply a Thin Coat To Shaft.
38,49 2/3 Oz. Type "E" Grease, 49-08-4121 On Gears.
42,43 1/3 Oz. of Type "E" Grease Between the 26 Steel Balls and Thrust Washer.
45 A Dab of Type "E" Grease Inside the .750 Dia. Bore on The Rear Of The Assembly.

MILWAUKEE ELECTRIC TOOL CORPORATION
13135 W. LISBON RD., BROOKFIELD, WI 53005